

5 Piece Steel Sofa Set

Steel Frame with powder coating



Assembly Instructions

Made in China

The owner's manual contains important safety information as well as assembly, use and maintenance instructions. Keep the packaging and bags away from children and dispose of all packaging properly before use. Keep this manual for future reference.



**PLEASE DO NOT
RETURN THIS
PRODUCT
TO THE STORE**

We will be happy to correct any problems that you may have, or answer any of your questions regarding the purchase of this product. Please contact us at our Toll Free customer service number 1-800-599-8898 for any assistance and replacement parts. Thank You.

Dist. by TDC USA, Inc. Fairfield, NJ 07004

©2020 All Rights Reserved.

Made in China

Item 22474

www.tdcusainc.com

**WARNING!**





- **Keep all children and pets away from assembly area. Children and pets should be supervised when they are in the area of the product construction.**
- **Some parts may contain sharp edges. When assembling and using this product, basic safety precautions should always be.**
- **Please read all the instructions and warnings before assembling. In order to make the whole product adjust to the best, please install all the screws on the product and tighten all the screws after adjusting the product which can stand on the floor even. Not intended for commercial use.**
- **Check all bolts for tightness before use.**
- **IMPORTANT - check and tighten bolts often to keep them secure**

• **CHOKING HAZARD** - Small parts. Not suitable for children under 36 months. The product contains small parts, keep children away when assembling.



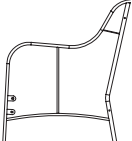
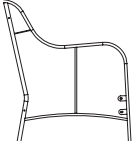

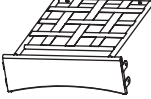
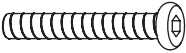
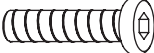
• **ADULT ASSEMBLY REQUIRED.**

Always remove protective material and poly bags and dispose before assembly.

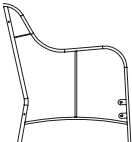

Chair Parts (x2)

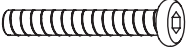
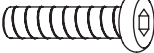
 <p>A (x1) Arm Rest</p>	 <p>B (x1) Arm Rest</p>	 <p>J (x1) Chair Back</p>	 <p>K (x1) Chair Seat</p>
 <p>E (x6) M6x40 Bolt</p>	 <p>F (x4) M6x25 Bolt</p>	 <p>G (x10) Washer</p>	 <p>H (x1) Hex Key</p>

Sofa Parts

 <p>A (x1) Arm Rest</p>	 <p>B (x1) Arm Rest</p>	 <p>C (x1) Sofa Back</p>	 <p>D (x1) Sofa Seat</p>
 <p>E (x8) M6x40 Bolt</p>	 <p>F (x4) M6x25 Bolt</p>	 <p>G (x12) Washer</p>	

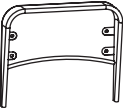
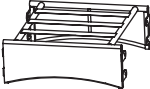
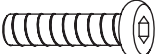
Ottoman Parts (x2)

 <p>L (x2) Legs</p>	 <p>M (x1) Foot Rest</p>	 <p>F (x8) M6x25 Bolt</p>	 <p>G (x8) Washer</p>

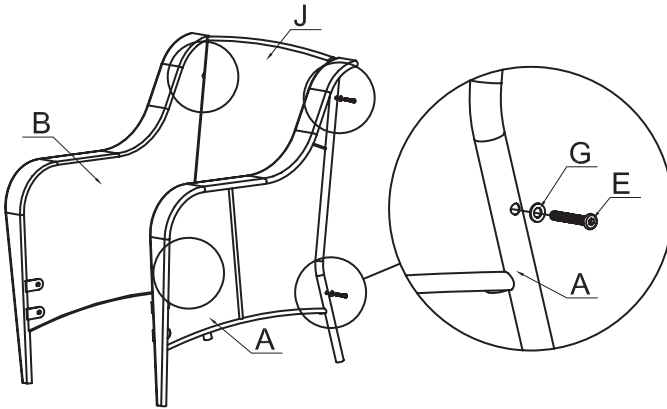

Step 1:

Insert two Bolts M6x40 (E) with Washers (G) through the sides of Arm Rest (A) and into the screw-threading found on the side of Chair Back (J); do not tighten bolts all the way until assembly is completed.

Insert two Bolts M6x40 (E) with Washers (G) through the sides of Arm Rest (B) and into the screw-threading found on the opposite side of Chair Back (J).

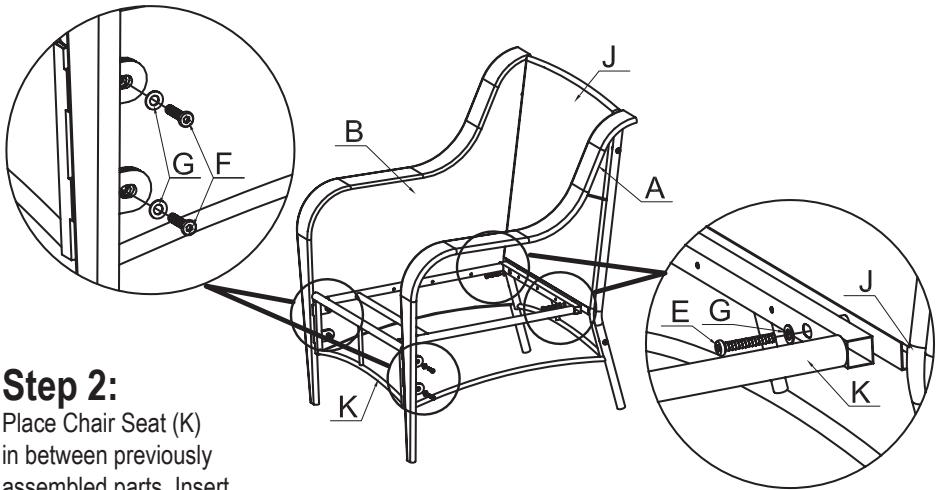

Step 2:

Place Chair Seat (K) in between previously assembled parts. Insert two Bolts M6x25 (F) with Washers (G) through holes found at the front leg of Arm Rest (A) and into screw-threading found on the side of Chair Seat (K).

Insert two Bolts M6x25 (F) with Washers (G) through holes found at the front leg of Arm Rest (B) and into screw-threading found on the opposite side of Chair Seat (K).

Insert two Bolts M6x40 (E) with Washers (G) holes found underneath Chair Seat (K) and into screw-threading found near the bottom of Chair Back (J).

Tighten all bolts left loose throughout assembly process. Follow these steps to assemble the second chair for this set.

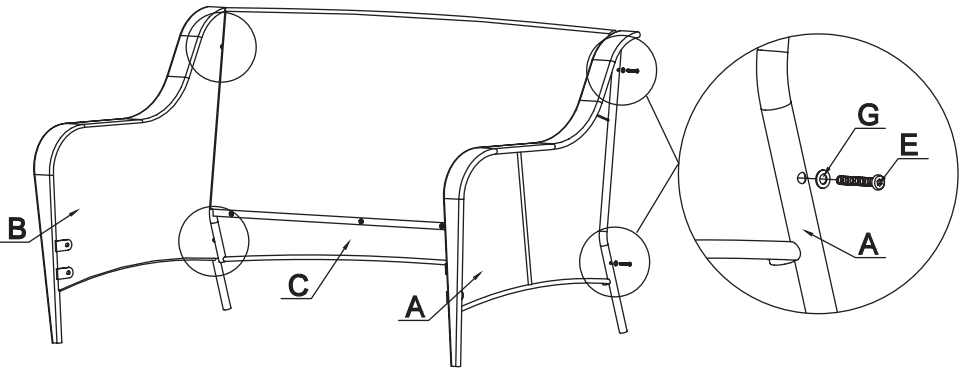

Step 1:

Insert two Bolts M6x40 (E) with Washers (G) through the sides of Arm Rest (A) and into the screw-threading found on the side of Sofa Back (C); do not tighten bolts all the way until assembly is completed.

Insert two Bolts M6x40 (E) with Washers (G) through the sides of Arm Rest (B) and into the screw-threading found on the opposite side of Sofa Back (C).

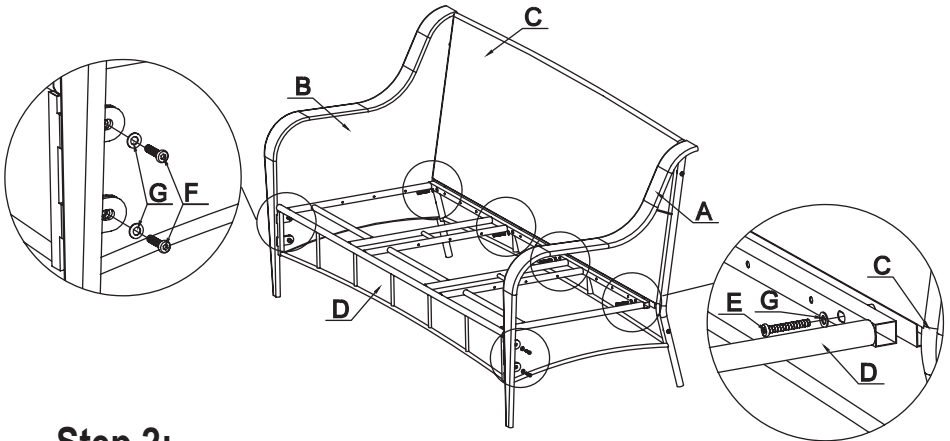

Step 2:

Place Sofa Seat (D) in between previously assembled parts. Insert two Bolts M6x25 (F) with Washers (G) through holes found at the front leg of Arm Rest (A) and into screw-threading found on the side of Sofa Seat (D).

Insert two Bolts M6x25 (F) with Washers (G) through holes found at the front leg of Arm Rest (B) and into screw-threading found on the opposite side of Sofa Seat (D).

Insert four Bolts M6x40 (E) with Washers (G) through holes found underneath Sofa Seat (D) and into screw-threading found near the bottom of Sofa Back (C).

Tighten all bolts left loose throughout assembly process.

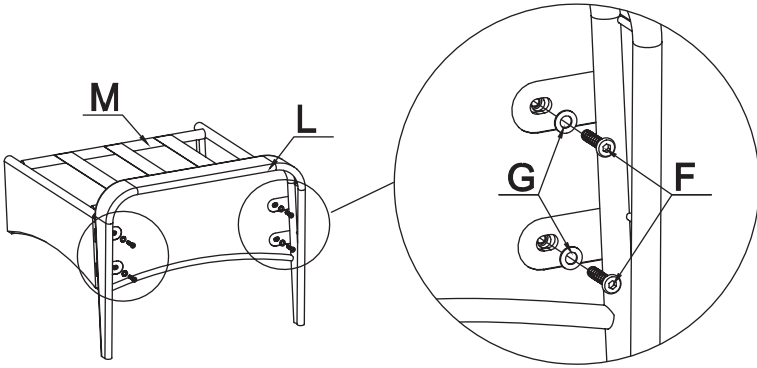

Step 1:

Place Leg (L) against Footrest (M). Insert two Bolts M6x25 (F) with Washers (G) through holes found by each leg of part L and into screw-threading of Footrest (M); do not tighten bolts all the way until assembly is completed.

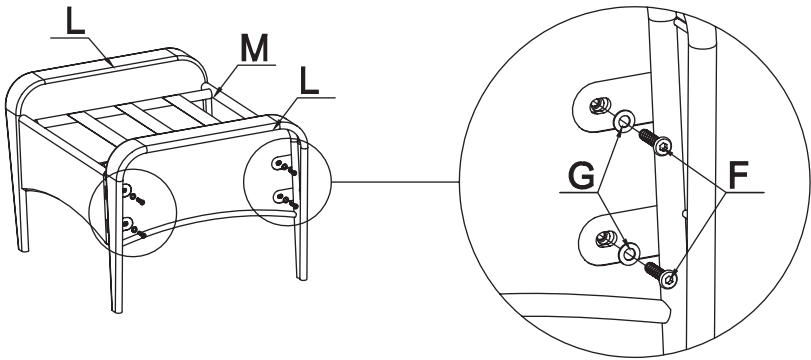

Step 2:

Place second Leg (L) against opposite side Footrest (M). Insert two Bolts M6x25 (F) with Washers (G) through holes found by each leg of part L and into screw-threading of Footrest (M).

Tighten all bolts left loose throughout assembly process. Follow these steps to assemble the second Ottoman for this set.

5 Piece Steel Sofa Set

Steel Frame with powder coating

Dist. by TDC USA, Inc. Fairfield, NJ 07004
©2020 All Rights Reserved. Made in China.
Item #22474

Questions and Comments
1-800-599-8898 (9 am - 5 pm EST)
www.tdcusainc.com