

# 4 Piece Wicker Sofa Set

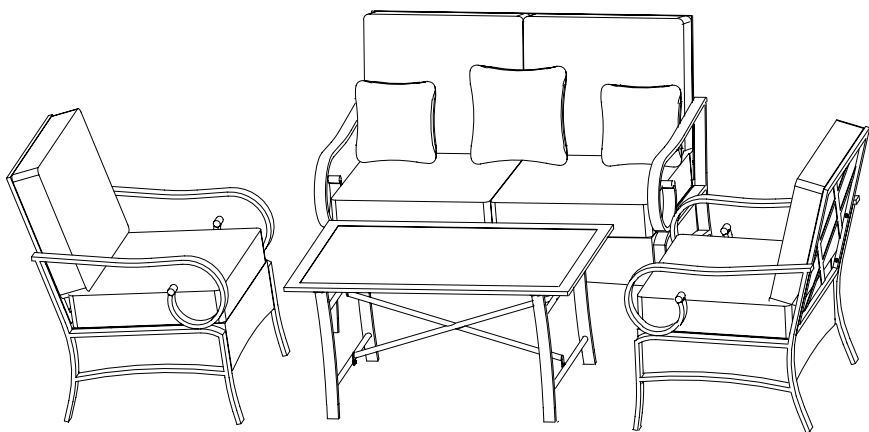

## Assembly Instructions

### **Made in China**

The owner's manual contains important safety information as well as assembly, use and maintenance instructions. Keep the packaging and bags away from children and dispose of all packaging properly before use. Keep this manual for future reference.

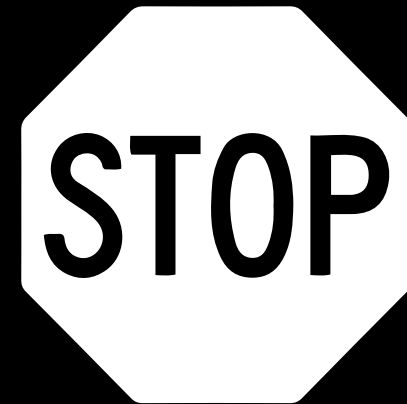

**PLEASE DO NOT  
RETURN THIS  
PRODUCT  
TO THE STORE**

**We will be happy to correct any problems that you may have, or answer any of your questions regarding the purchase of this product. Please contact us at our Toll Free customer service number 1-800-599-8898 for any assistance and replacement parts. Thank You.**







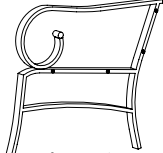
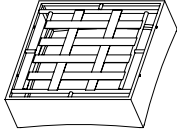
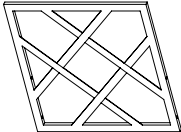
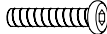
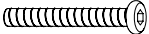

Dist. by TDC USA, Inc. Fairfield, NJ 07004  
©2020 All Rights Reserved.  
Made in China  
Item 22489  
[www.tdcusainc.com](http://www.tdcusainc.com)

 **WARNING!**

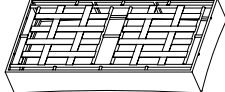
- Keep all children and pets away from assembly area. Children and pets should be supervised when they are in the area of the product construction.
- Some parts may contain sharp edges. When assembling and using this product, basic safety precautions should always be.
- Please read all the instructions and warnings before assembling. In order to make the whole product adjust to the best, please install all the screws on the product and tighten all the screws after adjusting the product which can stand on the floor even. Not intended for commercial use.
- Check all bolts for tightness before use.
- **IMPORTANT** - check and tighten bolts often to keep them secure

• **CHOKING HAZARD** - Small parts. Not suitable for children under 36 months. The product contains small parts, keep children away when assembling.

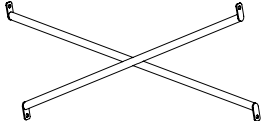
• **ADULT ASSEMBLY REQUIRED.**  
Always remove protective material and poly bags and dispose before assembly.

<b>A (x3)</b>  Armrest	<b>B (x3)</b>  Armrest	<b>C (x2)</b>  Chair Seat
<b>D (x2)</b>  Chair Back	<b>E (x8)</b>  M6x30 Bolt	<b>F (x8)</b>  M6x45 Bolt
<b>G (x28)</b>  Washer	<b>H (x1)</b>  Sofa Seat	<b>J (x1)</b>  Sofa Back
<b>L (x1)</b>  Table	<b>M (x2)</b>  Table Legs	<b>N (x1)</b>  Leg Support
<b>K (x12)</b>  M6x15 Bolt	<b>P (x1)</b>  Hex Key	

\* 2 Chairs are included in this set

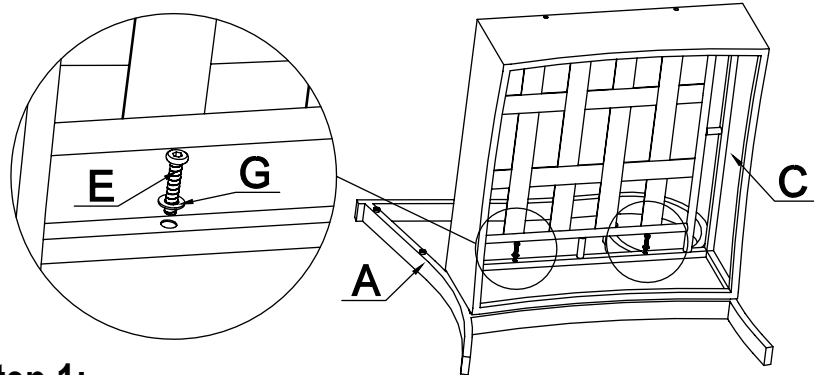

**Step 1:**

Set Armrest (A) on the ground so that the rear leg is to your left and front leg is to your right. Set Chair Seat (C) onto Armrest (A) as illustrated here. Insert two Bolts M6x30 (E) with Washers (G) through interior frame bar of Chair Seat (C) and into the screw-threading found on the middle horizontal bar of Armrest (A); do not tighten bolts all the way until assembly is completed.

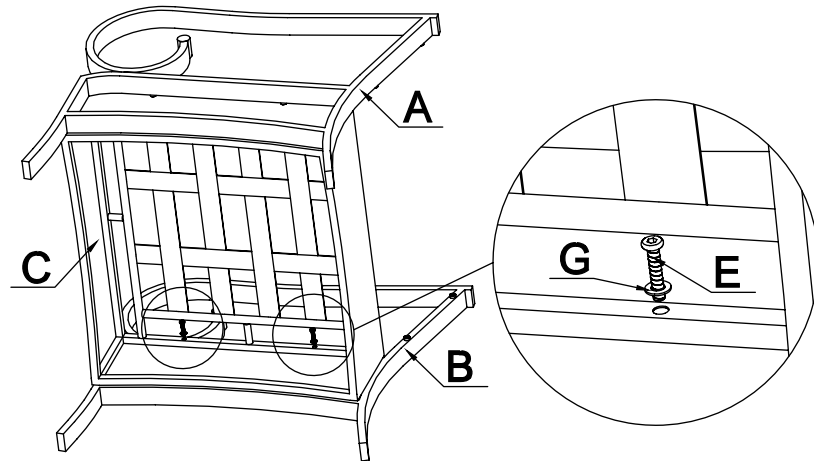

**Step 2:**

Set Armrest (B) on the ground so that the rear leg is to your right and front leg is to your left. Place opposite side of Chair Seat (C) onto Armrest (B) as illustrated here. Insert two Bolts M6x30 (E) with Washers (G) through interior frame bar of Chair Seat (C) and into the screw-threading found on the middle horizontal bar of Armrest (B); do not tighten bolts all the way until assembly is completed.

\* 2 Chairs are included in this set

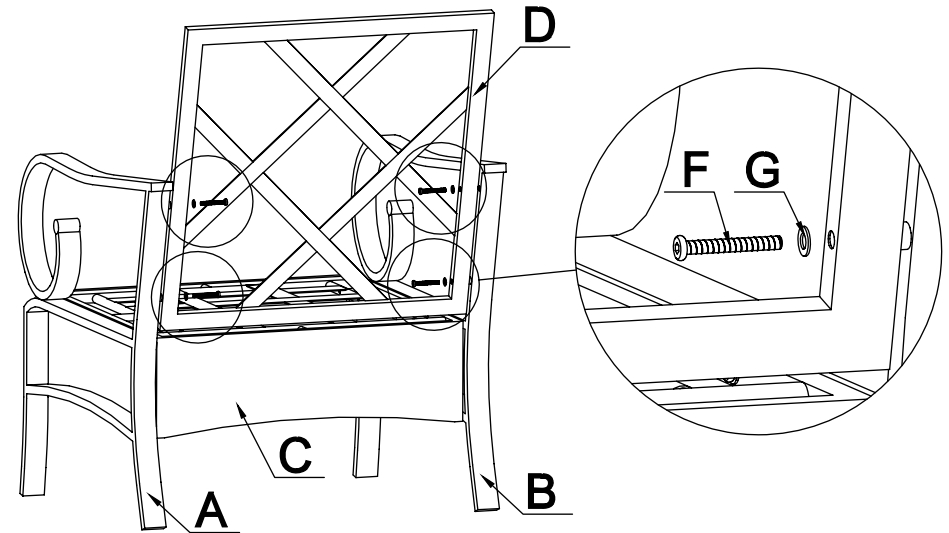

**Step 3:**

Place Chair Back (D) in between Armrest (A & B) as illustrated here. Insert two Bolts M6x45 (F) and Washers (G) through the side of Chair Back (D) and into the two screw-threading found near the top of the rear leg of Armrest (B). Insert two Bolts M6x45 (F) through the side of Chair Back (D) and into the two screw-threading found near the top of the rear leg of Armrest (A). Tighten all bolts left loose throughout assembly process using Hex Key (P). Follow these steps to assemble the second chair for this set. Place a seat cushion onto Chair Seat (C) and back cushion against Chair Back (D).

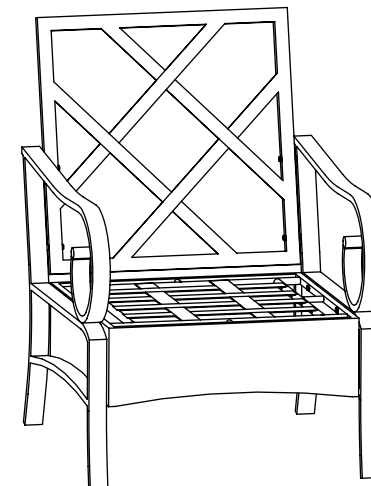

**Step 1:**

Set Armrest (A) on the ground so that the rear leg is to your left and front leg is to your right. Set Sofa Seat (H) onto Armrest (A) as illustrated here. Insert two Bolts M6x30 (E) with Washers (G) through interior frame bar of Sofa Seat (H) and into the screw-threading found on the middle horizontal bar of Armrest (A); do not tighten bolts all the way until assembly is completed.

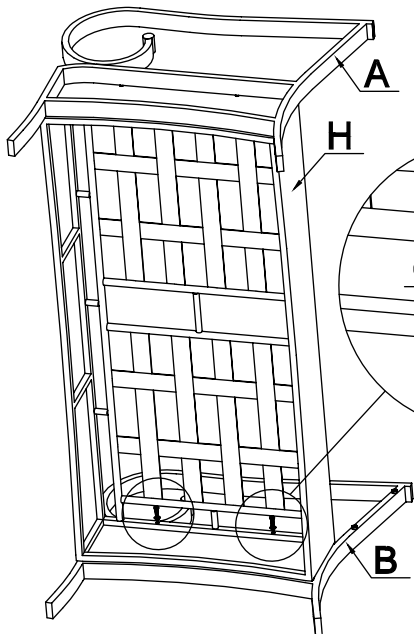
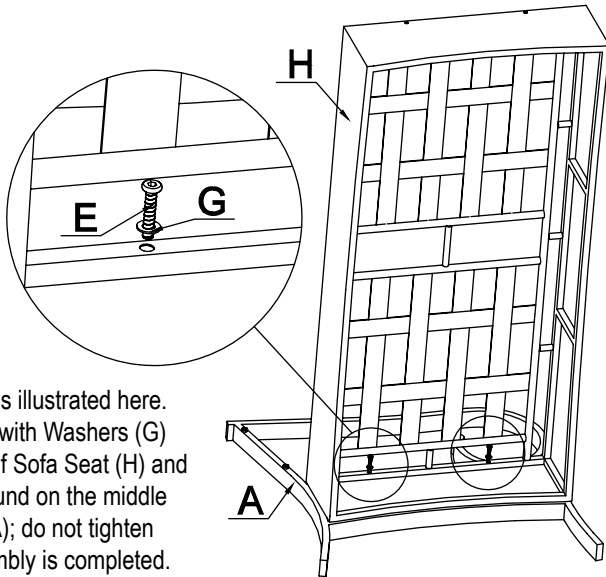

**Step 2:**

Set Armrest (B) on the ground so that the rear leg is to your right and front leg is to your left. Place opposite side of Sofa Seat (H) onto Armrest (B) as illustrated here. Insert two Bolts M6x30 (E) with Washers (G) through interior frame bar of Sofa Seat (H) and into the screw-threading found on the middle horizontal bar of Armrest (B); do not tighten bolts all the way until assembly is completed.

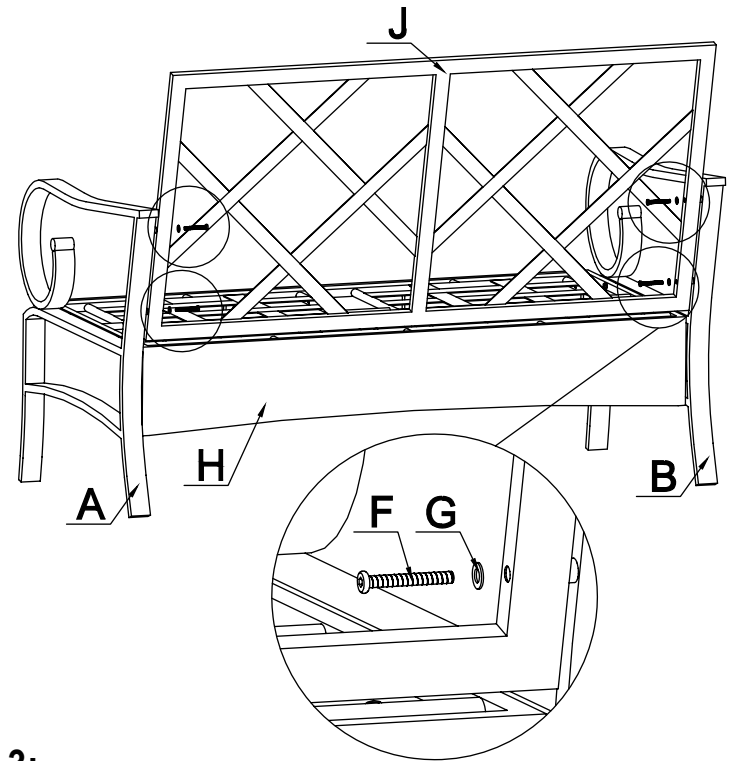

**Step 3:**

Place Sofa Back (J) in between Armrest (A & B) as illustrated here. Insert two Bolts M6x45 (F) with Washers (G) through the side of Sofa Back (J) and into the two screw-threading found near the top of the rear leg of Armrest (B). Insert two Bolts M6x45 (F) through the side of Sofa Back (J) and into the two screw-threading found near the top of the rear leg of Armrest (A). Tighten all bolts left loose throughout assembly process using Hex Key (P). Place a seat cushion onto Sofa Seat (H) and back cushion against Sofa Back (J).

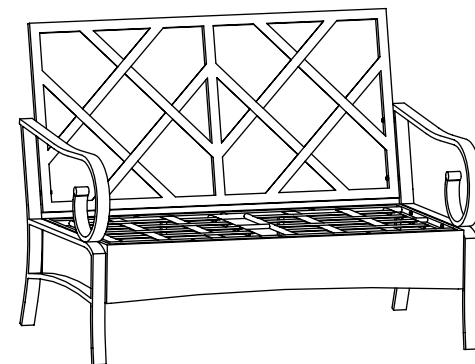

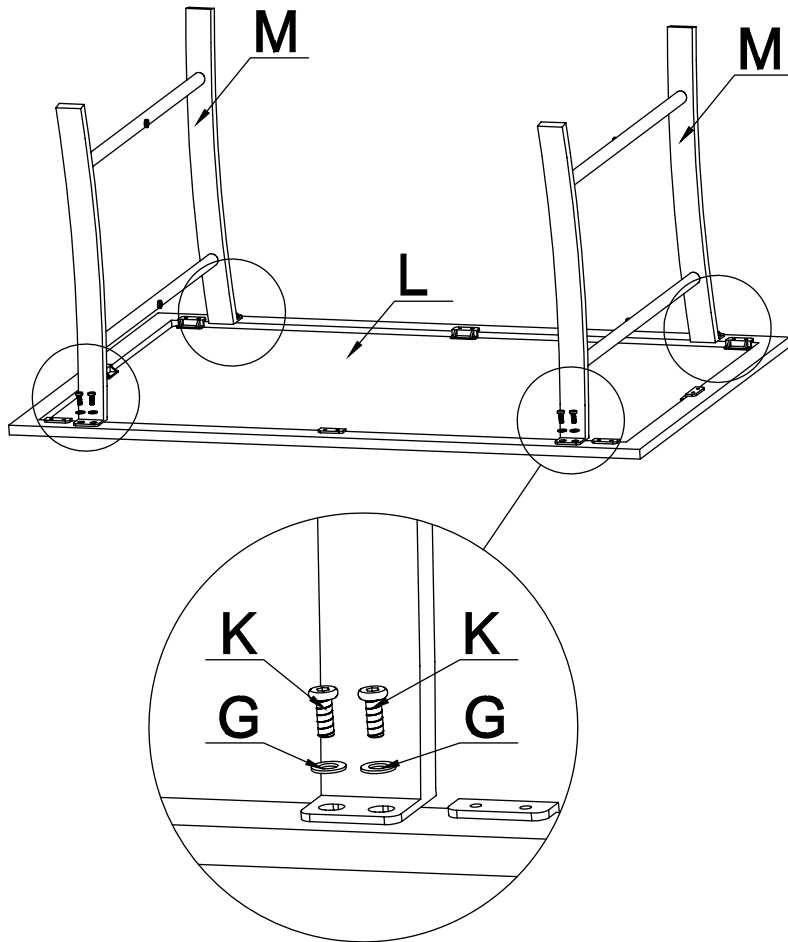

### Step 1:

Carefully place Table (L) upside down on the ground; be mindful of the glass surface when setting it down. Place Table Leg (M) over table rim where there are screw-threading intended for bolts to be inserted into.

Insert two Bolts M6x15 (K) with Washers (G) through holes found at the top of each leg of Table Leg (M) and into the screw-threading of rim of Table (L); do not tighten bolts all the way until assembly is completed. Follow these steps to assemble the second Table Leg (H) on the opposite side of Table (L).

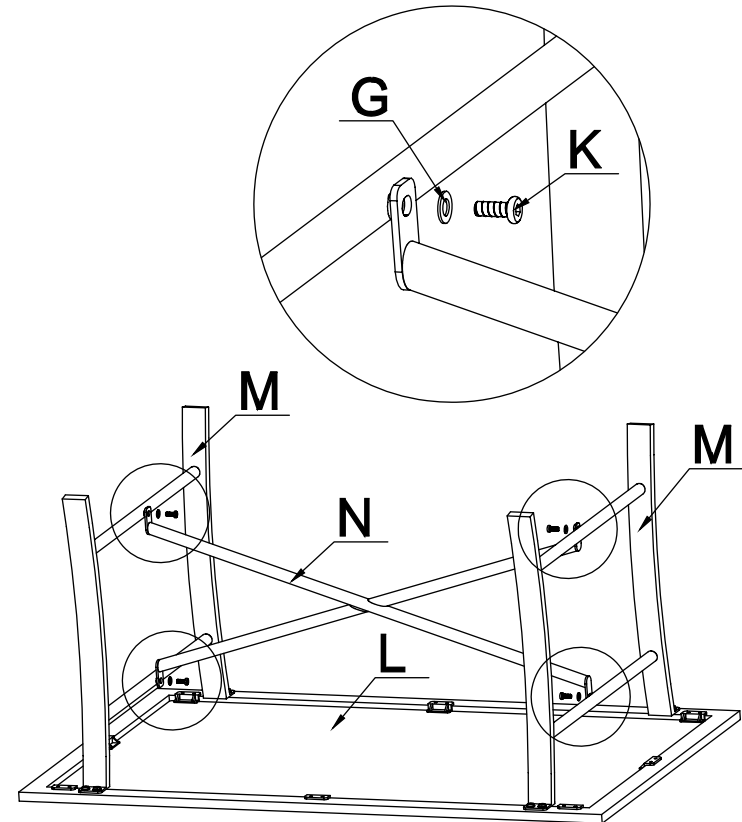

### Step 2:

Place Table Support (N) in between Table Legs (M).

Insert one Bolt M6x15 (K) with Washer (G) through holes found at the ends of Table Support (N) and into the screw-threading on both horizontal bars of Table Leg (M). Follow this step to secure the opposite side Table Support (N) to the second Table Leg (M). Tighten all bolts left loose throughout assembly process using Hex Key (P). Carefully turn the table right-side up when finished.

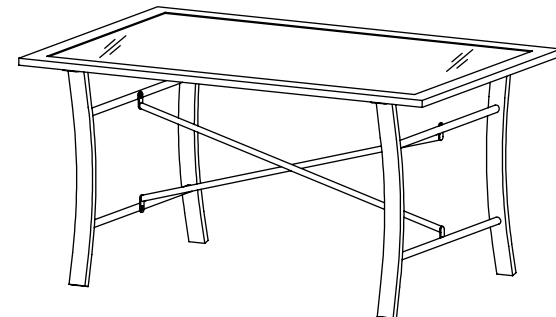

# 4 Piece Wicker Sofa Set

Dist. by TDC USA, Inc. Fairfield, NJ 07004  
©2020 All Rights Reserved. Made in China.  
Item #22489

**Questions and Comments**  
**1-800-599-8898 (9 am - 5 pm EST)**  
**[www.tdcusainc.com](http://www.tdcusainc.com)**