

Wicker Sectional Sofa Set



Assembly Instructions

Made in Vietnam

The owner's manual contains important safety information as well as assembly, use and maintenance instructions. Keep the packaging and bags away from children and dispose of all packaging properly before use. Keep this manual for future reference.



**PLEASE DO NOT
RETURN THIS
PRODUCT
TO THE STORE**

We will be happy to correct any problems that you may have, or answer any of your questions regarding the purchase of this product. Please contact us at our Toll Free customer service number 1-800-599-8898 for any assistance and replacement parts. Thank You.





Dist. by TDC USA, Inc. Fairfield, NJ 07004
©2021 All Rights Reserved.
Made in Vietnam
Item 21746
www.tdcusainc.com

⚠ WARNING!

- **Keep all children and pets away from assembly area. Children and pets should be supervised when they are in the area of the product construction.**
- **Some parts may contain sharp edges. When assembling and using this product, basic safety precautions should always be.**
- **Please read all the instructions and warnings before assembling. In order to make the whole product adjust to the best, please install all the screws on the product and tighten all the screws after adjusting the product which can stand on the floor even. Not intended for commercial use.**
- **Check all bolts for tightness before use.**
- **IMPORTANT - check and tighten bolts often to keep them secure**

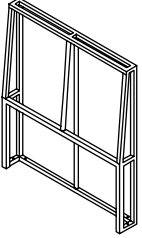
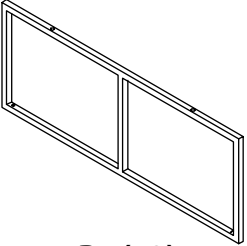
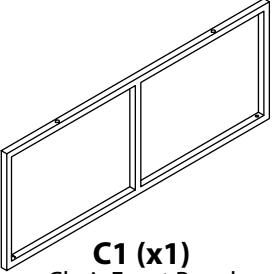
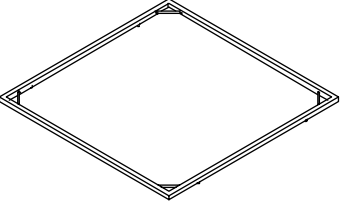
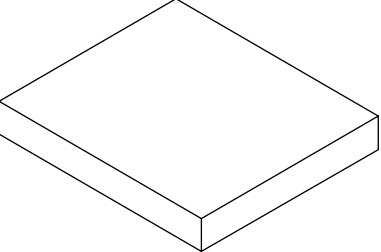
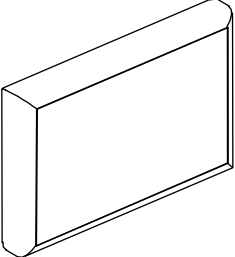
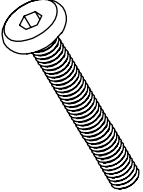
• **CHOKING HAZARD** - Small parts. Not suitable for children under 36 months. The product contains small parts, keep children away when assembling.

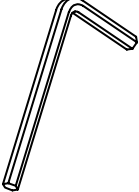
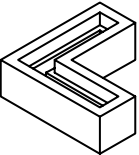
• **ADULT ASSEMBLY REQUIRED.**
Always remove protective material and poly bags and dispose before assembly.

 <p>A1 (x1) Chair Back</p>	 <p>B1 (x2) Chair Side Panel</p>			
 <p>C1 (x1) Chair Front Panel</p>	 <p>D1 (x1) Chair Seat</p>			
 <p>Seat Cushion</p>	 <p>Back Cushion</p>			
 <p>1 (x12) M6x35 Bolt</p>	 <p>2 (x12) Washer</p>	 <p>3 (x1) Hex Key</p>	 <p>4 (x4) Corner Foot</p>	 <p>5 (x8) M6x25 Bolt</p>

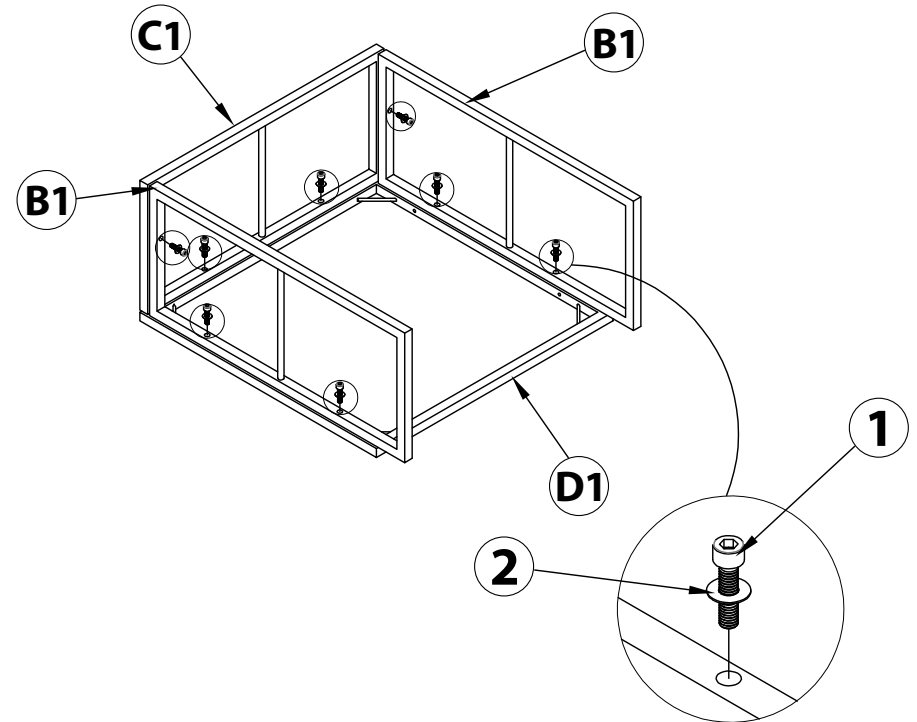

Step 1:

Set the Chair Seat (D1) upside-down on a soft, non-abrasive surface.

Insert two M6x35 Bolts (1) with Washers (2) through the top of Chair Side Panel (B1) and into Chair Seat (D1). **Do not tighten bolts all the way until all parts have been assembled.** Place Chair Front Panel (C1) next to previously assembled Chair Side Panel (B1) and insert two M6x35 Bolts (1) with Washers (2) through the top of Chair Front Panel (C1) and into Chair Seat (D1). Place second Chair Side Panel (B1) against previously assembled parts and insert two M6x35 Bolts (1) with Washers (2) through the top of Chair Side Panel (B1) and into Chair Seat (D1). Insert one M6x35 Bolts (1) through the ends of both Chair Side Panels (B1) and into the ends of Chair Front Panel (C1).

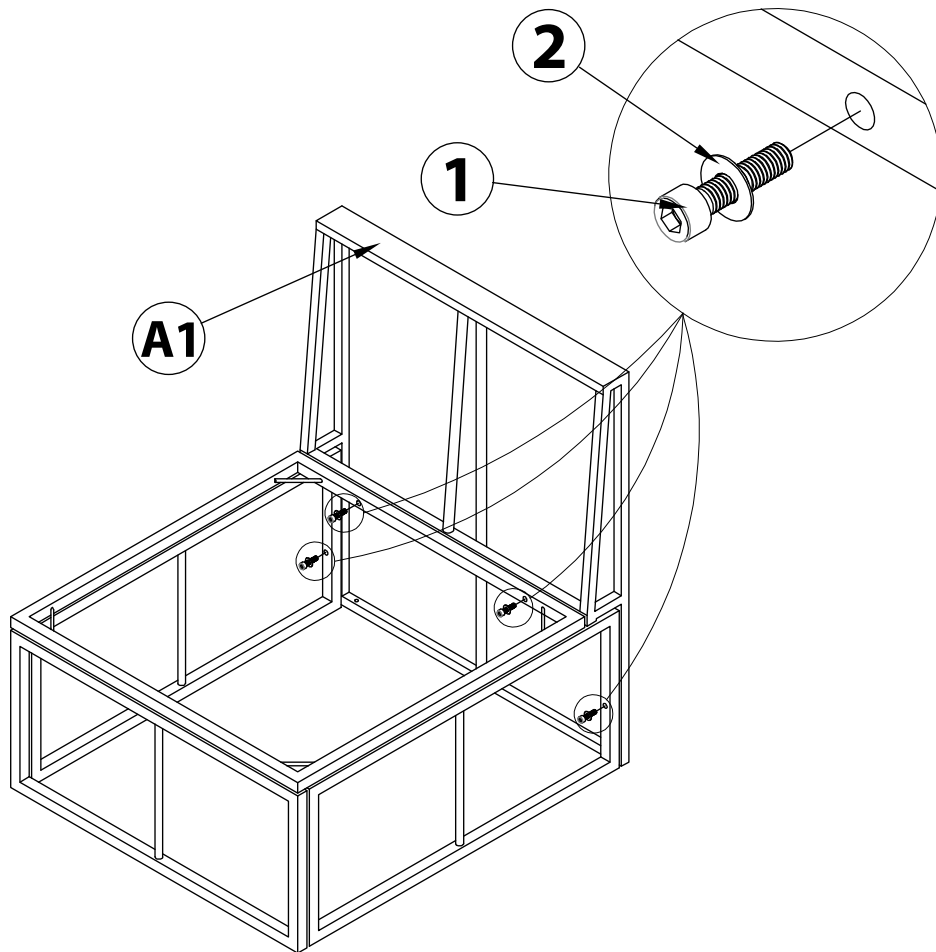

Step 2:

Turn previously assembled parts right-side up. Place Chair Back (A1) against Chair Seat (D1) as illustrated here. Insert two M6x35 Bolts (1) with Washers (2) through eyelets found underneath Chair Seat (D1) and into bolt-threading found at the bottom of the chair back of A1. Insert one M6x35 Bolt (1) with Washer (2) through the sides of both Chair Side Panels (B1) and into the bolt-threading found at the bottom of Chair Back (A1).

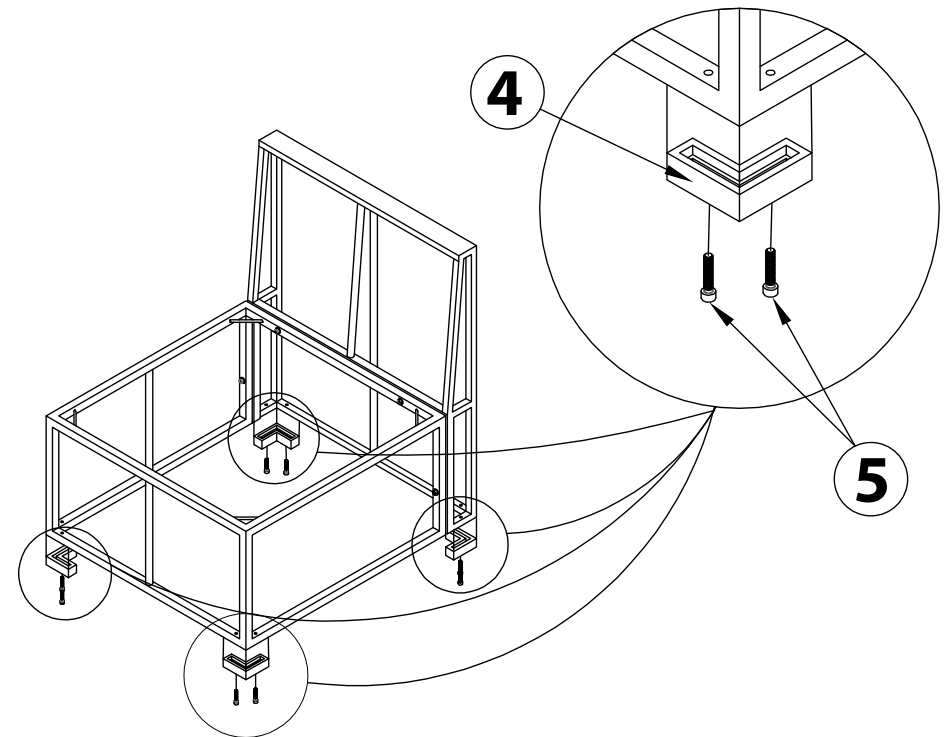



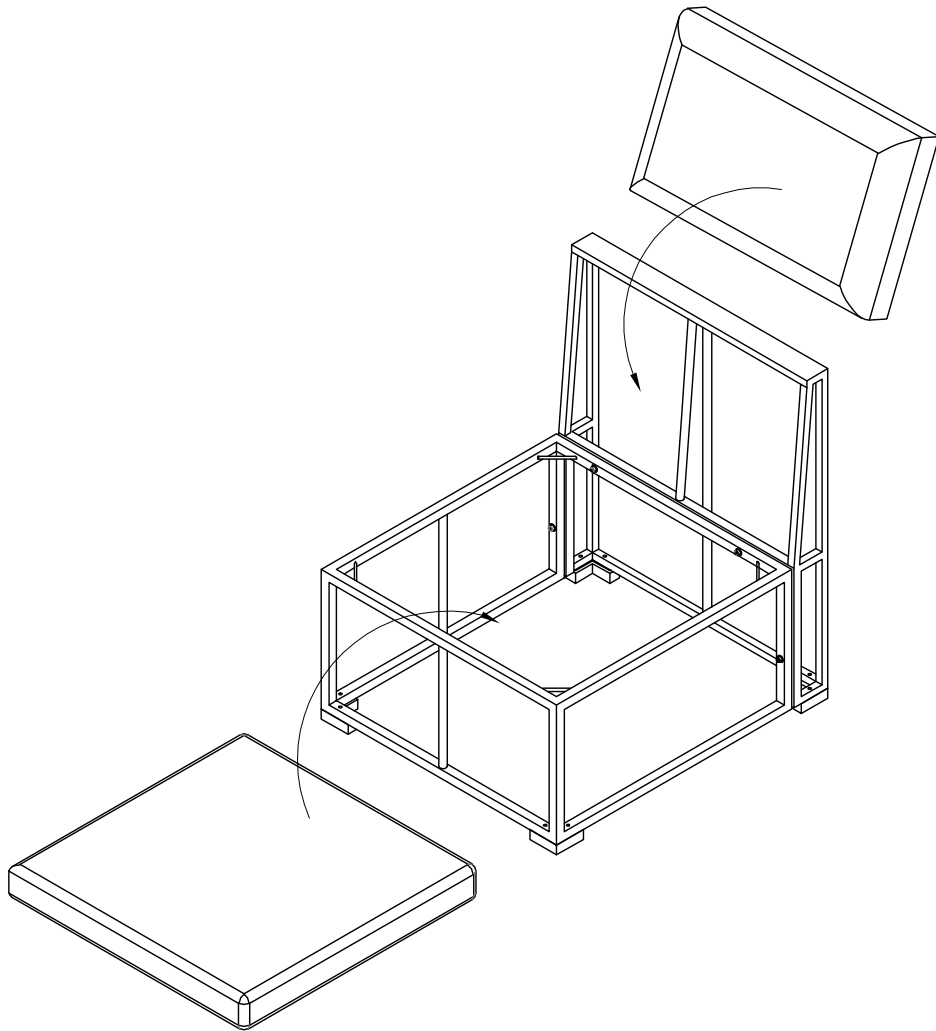

Step 3:

Place Corner Feet (4) at either corner of chair. Insert two M6x25 Bolts (5) through each Corner Foot (4) and into the bottoms of all previously assembled parts. Tighten bolts using Hex Key (3). Turn the chair right-side up when finished.

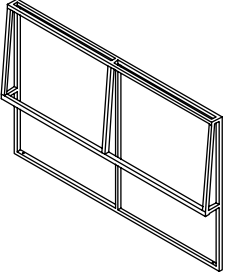
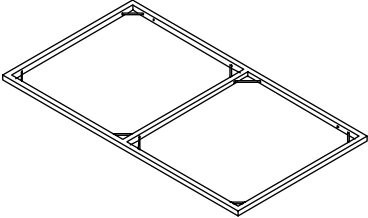
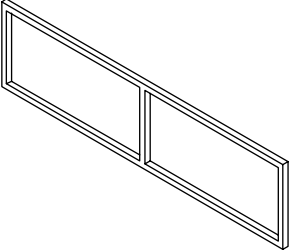
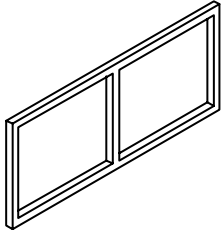
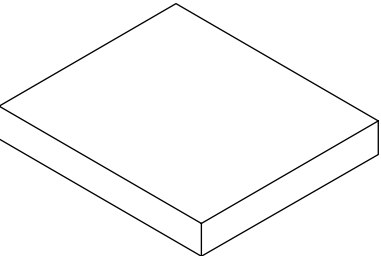
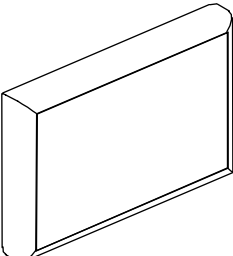
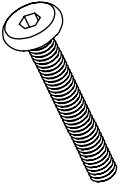

Step 4:

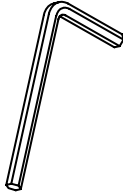
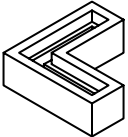
Place a seat cushion and back cushion on top when ready to use.

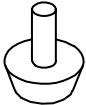
 <p>A2 (x1) Sofa Back</p>	 <p>B2 (x1) Sofa Seat</p>				
 <p>C2 (x1) Sofa Front Panel</p>	 <p>D2 (x3) Sofa Panel</p>				
 <p>Seat Cushion (x2)</p>	 <p>Back Cushion (x2)</p>				
 <p>1 (x16) M6x35 Bolt</p>	 <p>2 (x16) Washer</p>	 <p>3 (x1) Hex Key</p>	 <p>4 (x4) Corner Foot</p>	 <p>5 (x8) M6x25 Bolt</p>	 <p>6 (x2) Foot</p>

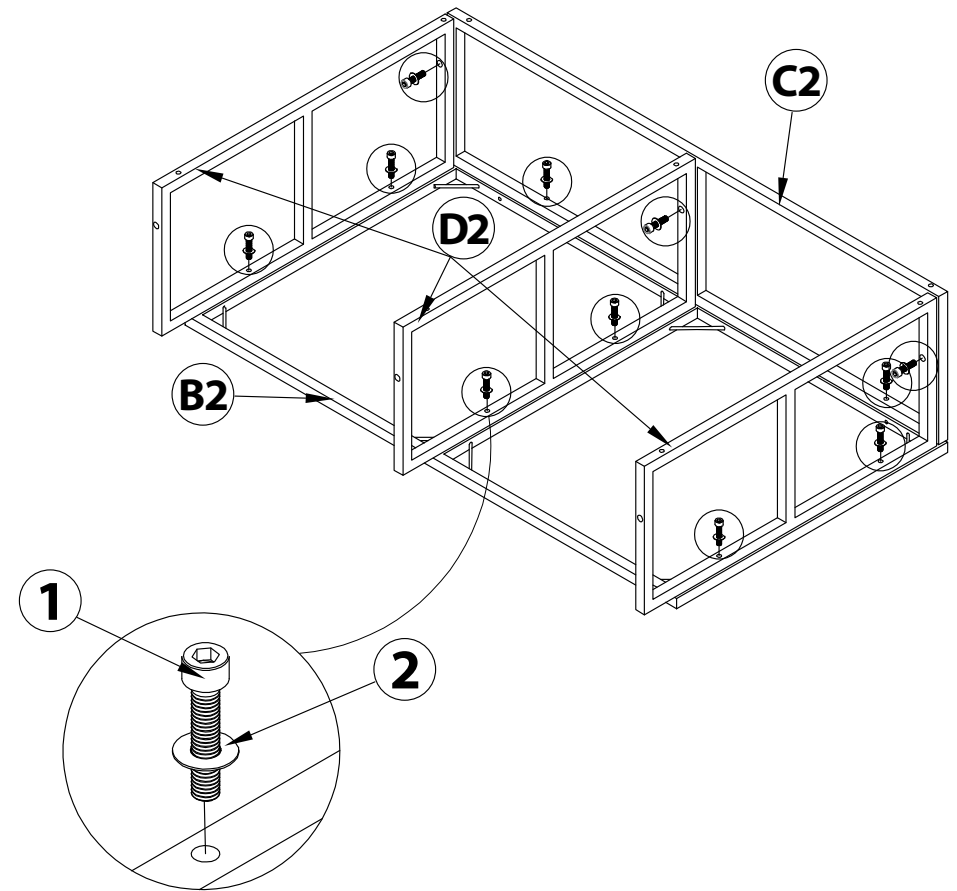

Step 1:

Set the Sofa Seat (B2) upside-down on a soft, non-abrasive surface.

Insert two M6x35 Bolts (1) with Washers (2) through the top of Sofa Front Panel (C2) and into Sofa Seat (B2). **Do not tighten bolts all the way until all parts have been assembled.** Insert two M6x35 Bolts (1) with Washers (2) through the top of Sofa Panel (D2) and into the left-side of Sofa Seat (B2). Insert two M6x35 Bolts (1) with Washers (2) through the top of Sofa Panel (D2) and into the middle of Sofa Seat (B2). Insert two M6x35 Bolts (1) with Washers (2) through the top of Sofa Panel (D2) and into the right-side of Sofa Seat (B2). Insert one M6x35 Bolts (1) through the ends of all Sofa Panels (D2) and into the ends and middle of Sofa Seat (B2).

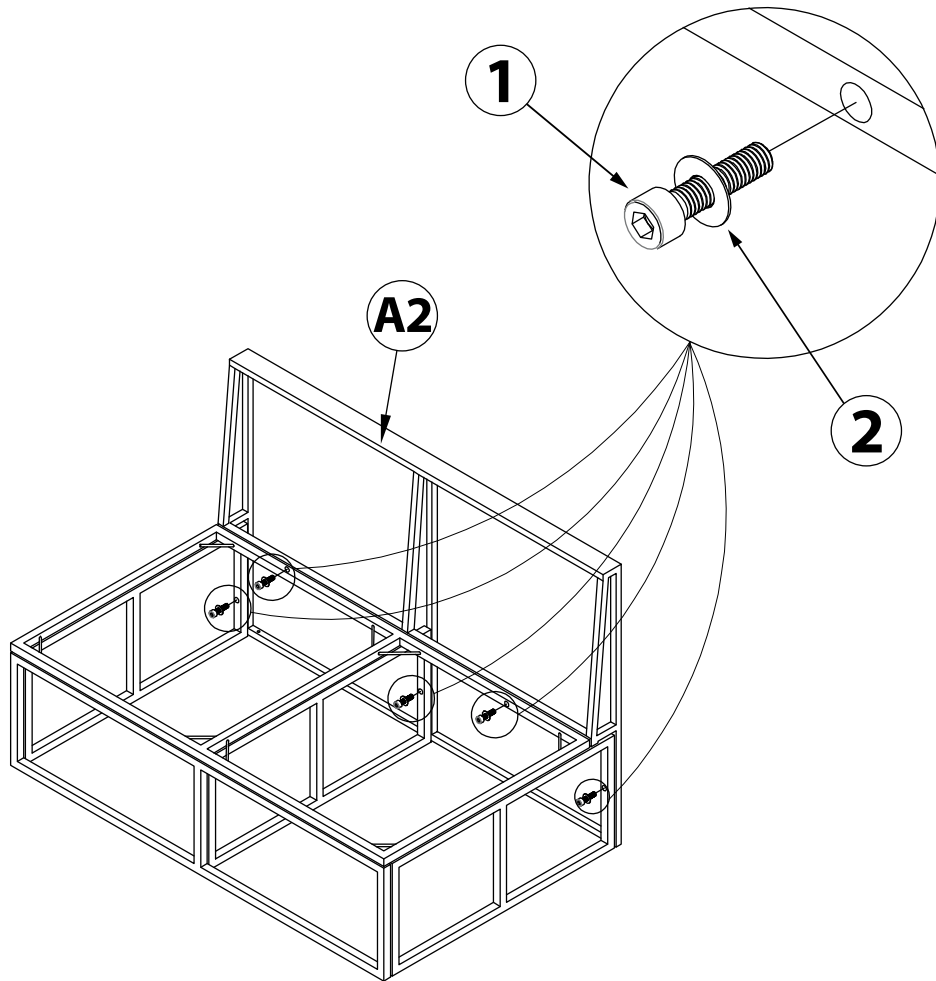

Step 2:

Turn previously assembled parts right-side up. Place Sofa Back (A2) against Sofa Seat (B2) as illustrated here. Insert two M6x35 Bolts (1) with Washers (2) through eyelets found underneath Sofa Seat (B2) and into bolt-threading found at the bottom of the sofa back of A2. Insert one M6x35 Bolt (1) with Washer (2) through the sides of all Sofa Panels (D2) and into the bolt-threading found at the bottom of Sofa Back (A2).

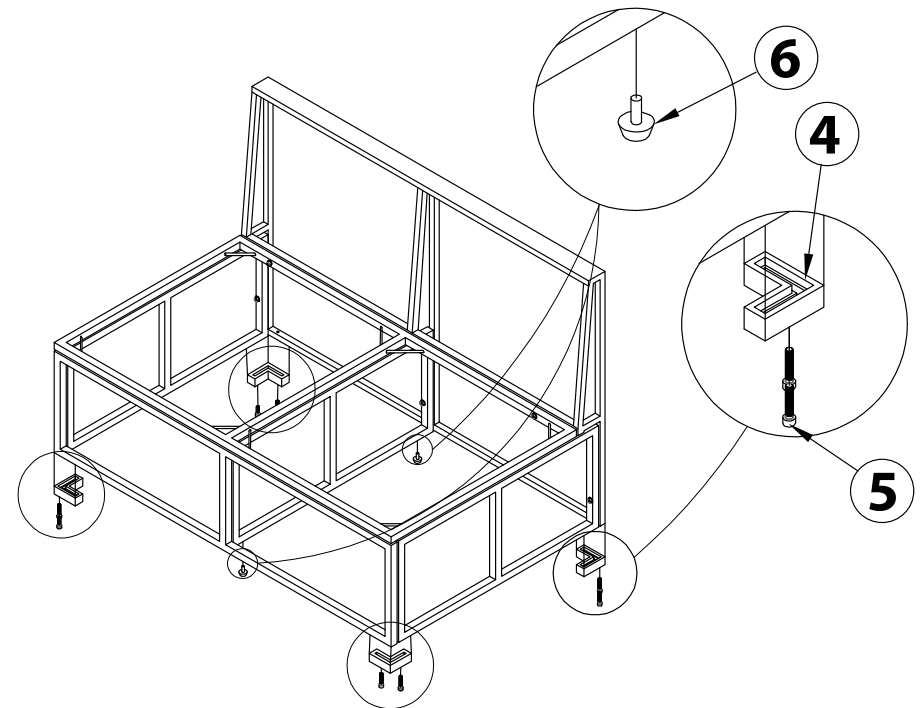

Step 3:

Place Corner Feet (4) at either corner of sofa. Insert two M6x25 Bolts (5) through each Corner Foot (4) and into the bottoms of all previously assembled parts. Tighten bolts using Hex Key (3). Insert two Feet (6) into the bolt-threading on the bottom of the middle Sofa Panel (D2). Turn the chair right-side up when finished.

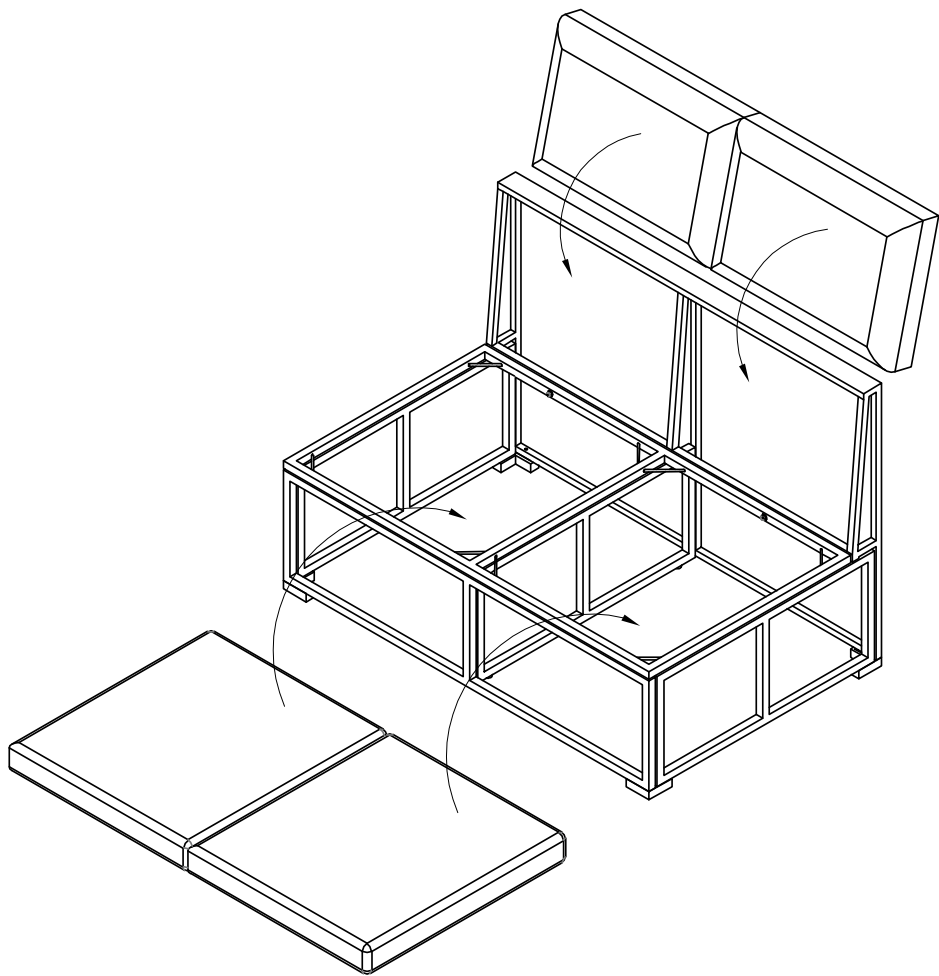

Step 4:

Place two seat cushions and back cushions on top when ready to use.

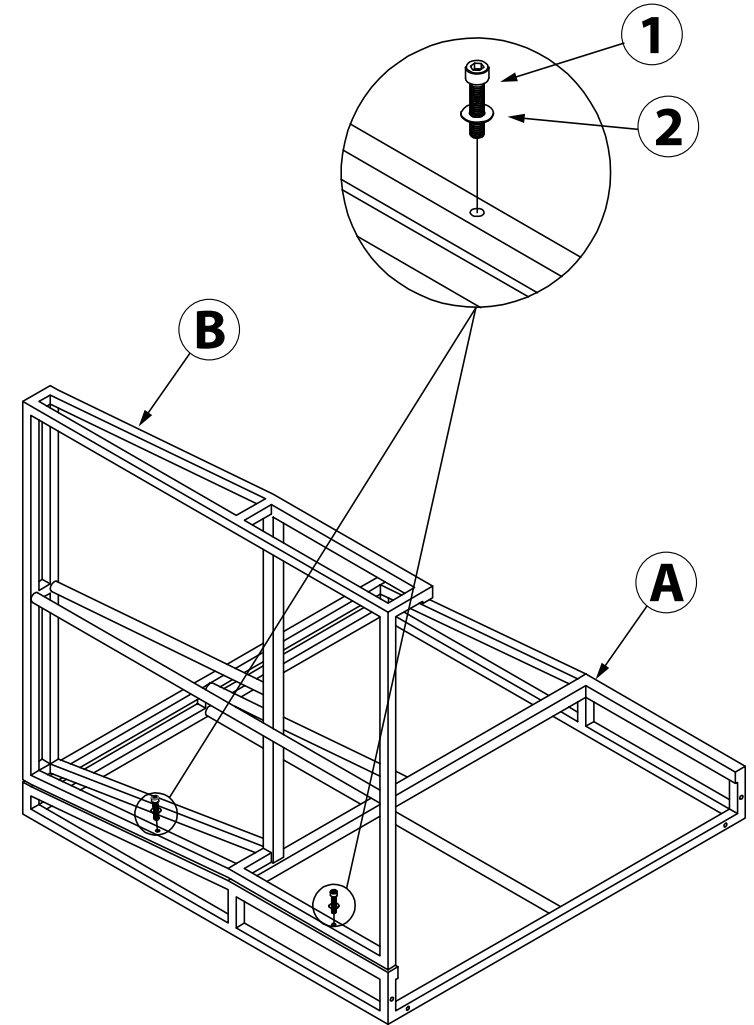
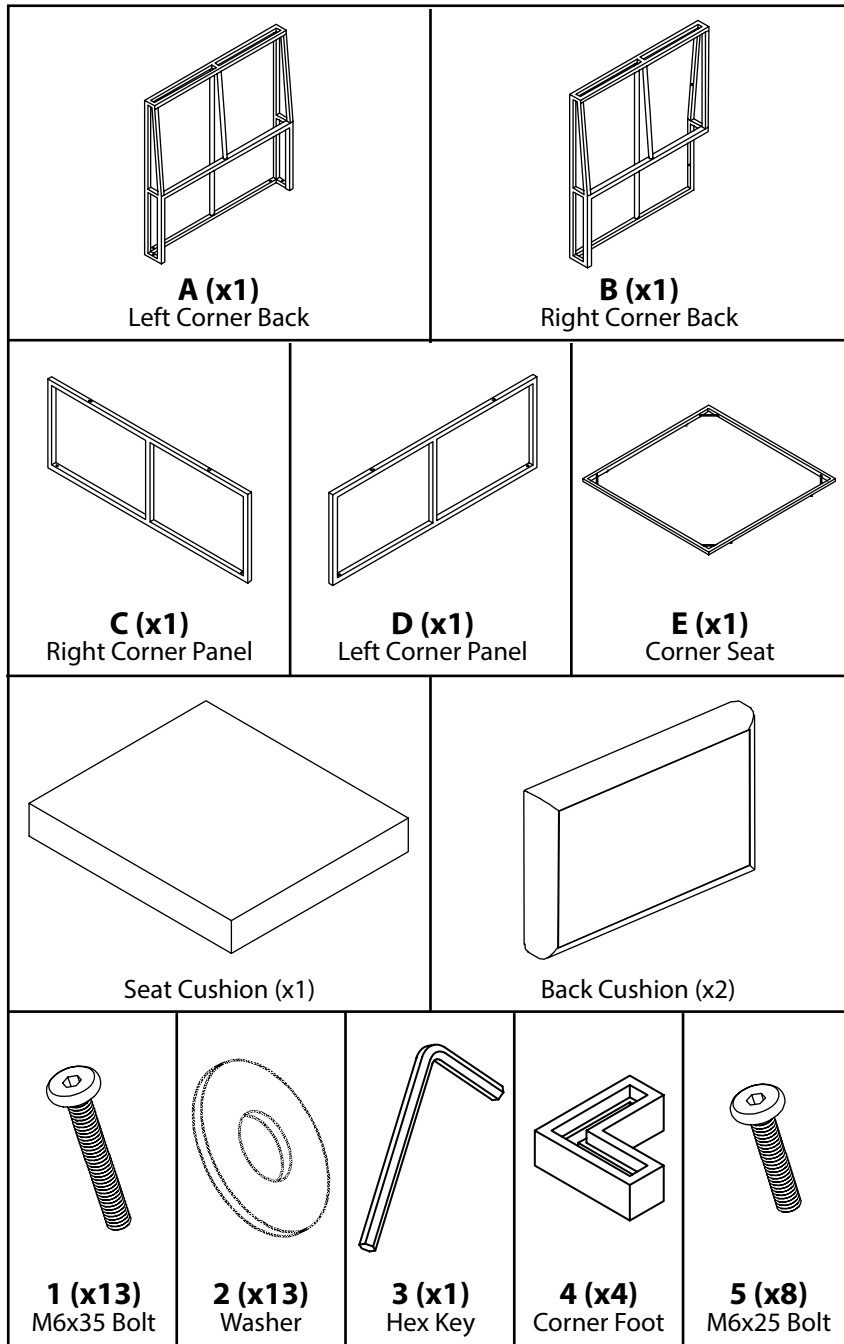

Step 1:

Bring Right Corner Back (B) and Left Corner Back (A) together as illustrated here. Insert one M6x35 Bolt (1) with Washer (2) through the bottom of Right Corner Back (B) and into bolt-threading found on Left Corner Back (A). **Do not tighten bolts all the way until all parts have been assembled.** Insert one M6x35 Bolt (1) with Washer (2) through the top of Right Corner Back (B) and into bolt-threading found on Left Corner Back (A).

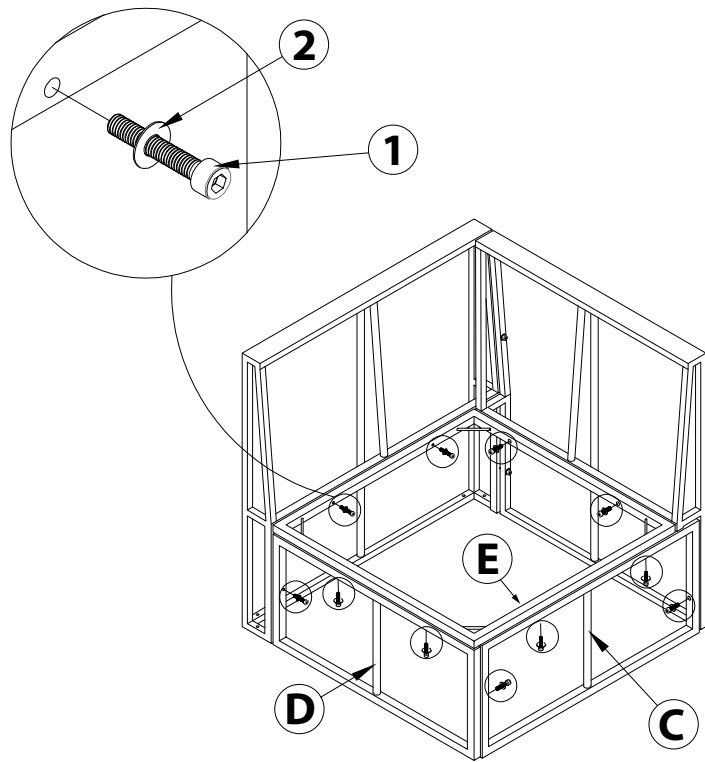

Step 2:

Turn previously assembled parts right-side up. Place assembled Corner Backs (A & B) against Corner Seat (E) as illustrated here. Insert two M6x35 Bolts (1) with Washers (2) through eyelets found underneath Corner Seat (E) and into bolt-threading found at the bottom Right Corner Back (B). Insert two M6x35 Bolts (1) with Washers (2) through eyelets found underneath Corner Seat (E) and into bolt-threading found at the bottom Left Corner Back (A).

Insert one M6x35 Bolt (1) with Washer (2) through the side of Left Corner Panel (C) and into the bolt-threading found at the bottom of Left Corner Back (A). Insert one M6x35 Bolt (1) with Washer (2) through the side of Right Corner Panel (D) and into the bolt-threading found at the bottom of Right Corner Back (B). Insert one M6x35 Bolt (1) with Washer (2) through the other side of Left Corner Panel (C) and into the bolt-threading found at the other end of Right Corner Panel (D).

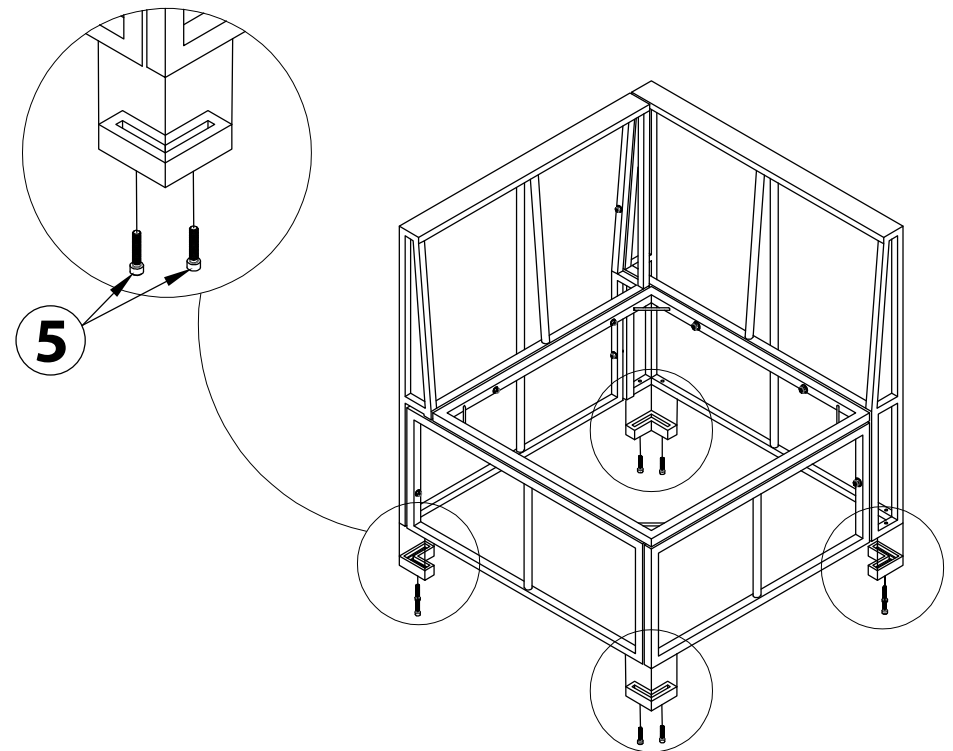

Step 3:

Place Corner Feet (4) at either corner of corner. Insert two M6x25 Bolts (5) through each Corner Foot (4) and into the bottoms of all previously assembled parts. Tighten bolts using Hex Key (3). Turn the corner chair right-side up when finished.

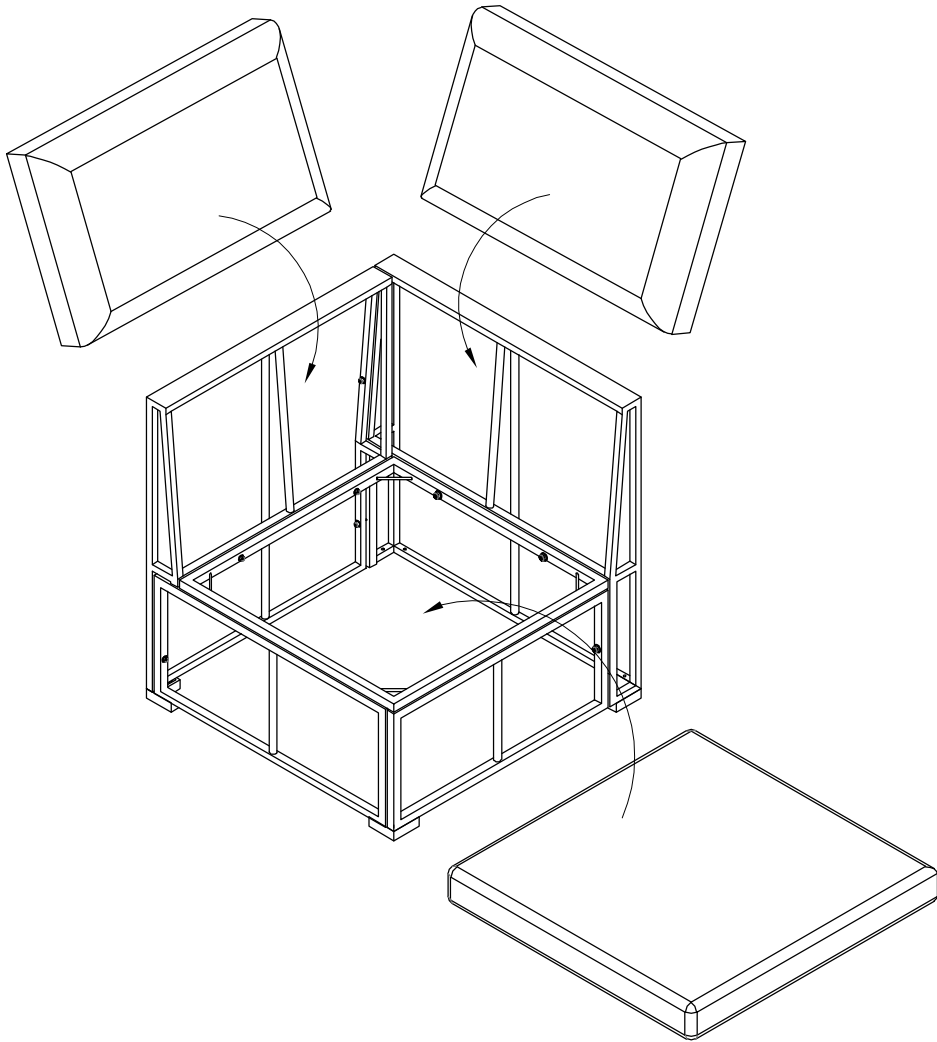

Step 4:

Place one seat cushion, one large and one smaller back cushions on top when ready to use.

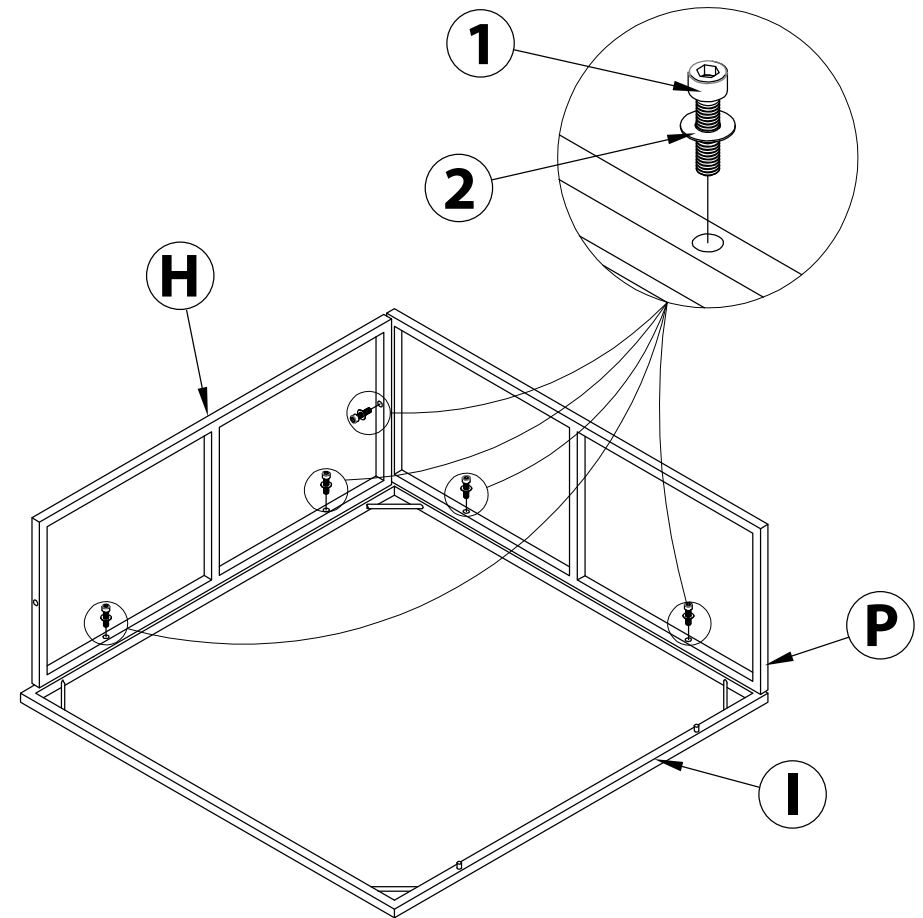
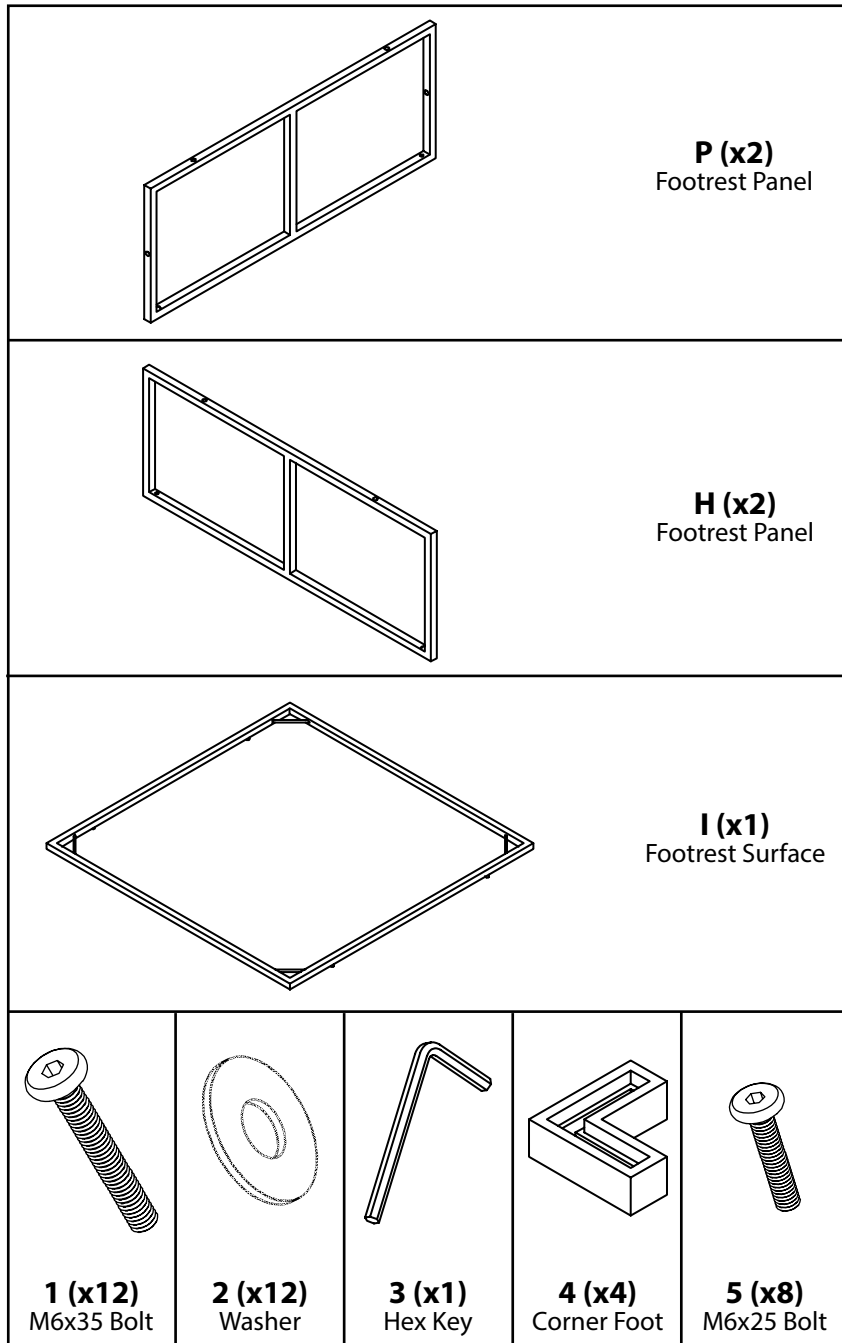
**Step 1:**

Set the Footrest Surface (I) upside-down on a soft, non-abrasive surface.

Insert two M6x35 Bolts (1) with Washers (2) through the top of Footrest Panel (P) and into Footrest Surface (I). Insert two M6x35 Bolts (1) with Washers (2) through the top of Footrest Panel (H) and into Footrest Surface (I).

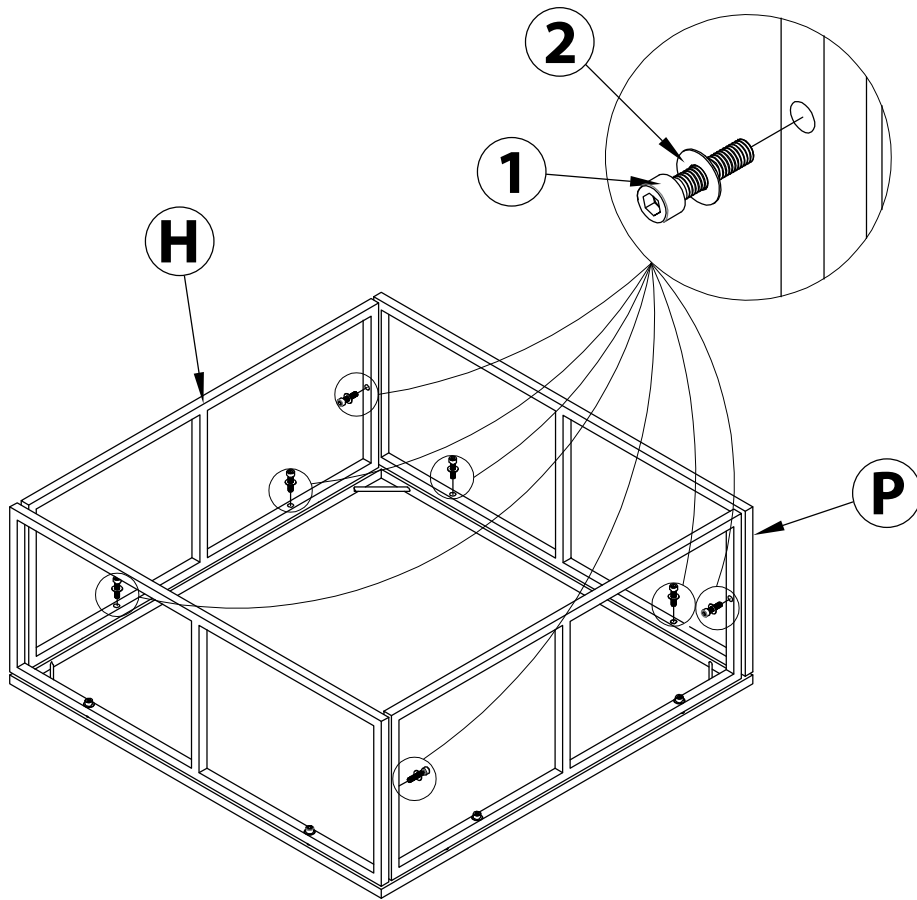

Step 2:

Place second Footrest Panel (P) next to the previously assembled Footrest Panel (H). Insert two M6x35 Bolts (1) with Washers (2) through the top of Footrest Panel (P) and into Footrest Surface (I). **Do not tighten bolts all the way until all parts have been assembled.** Place second Footrest Panel (H) against Footrest Surface (I) and use two M6x35 Bolts (1) with Washers (2) to connect these parts together.

Insert one M6x35 Bolt (1) with Washer (2) through either side of both Footrest Panels (H) and into both Footrest Panels (P).

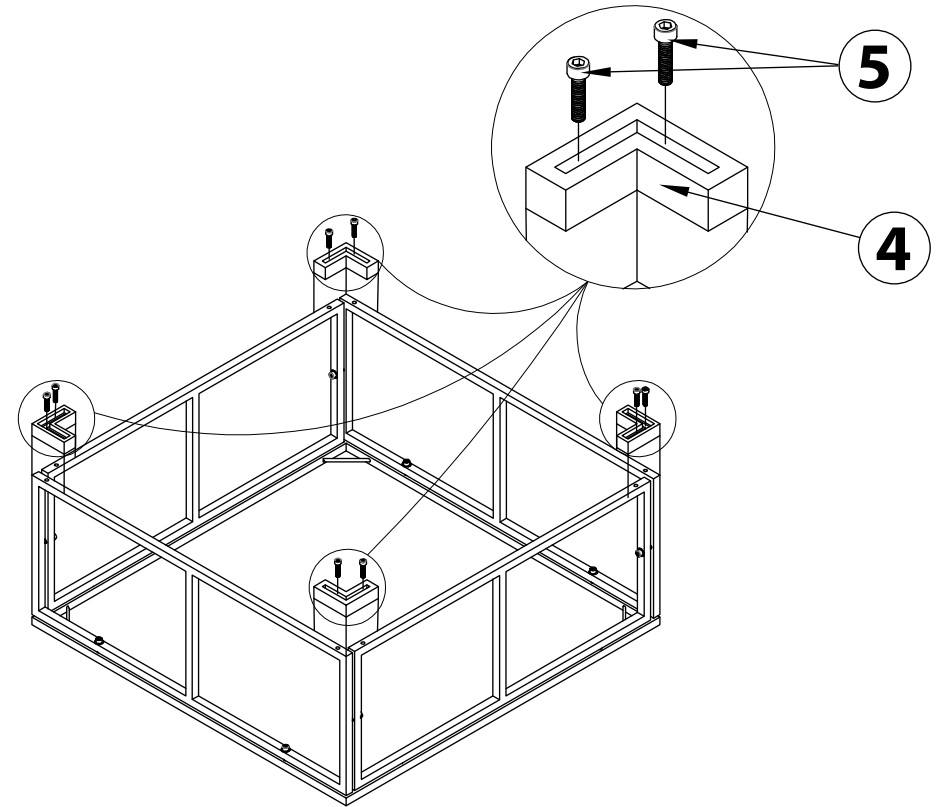

Step 3:

Place Corner Feet (4) at each corner of footrest. Insert two M6x25 Bolts (5) through each Corner Foot (5) and into the bottoms of all previously assembled parts. Tighten bolts using Hex Key (3).

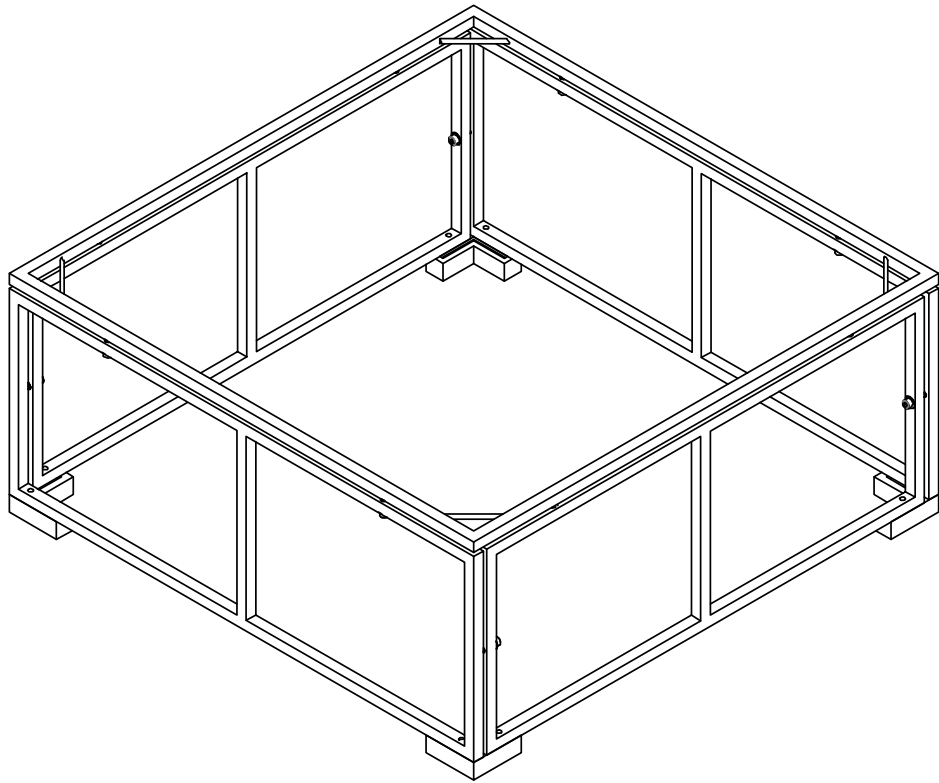

Step 4:

Turn the footrest right-side up when finished.

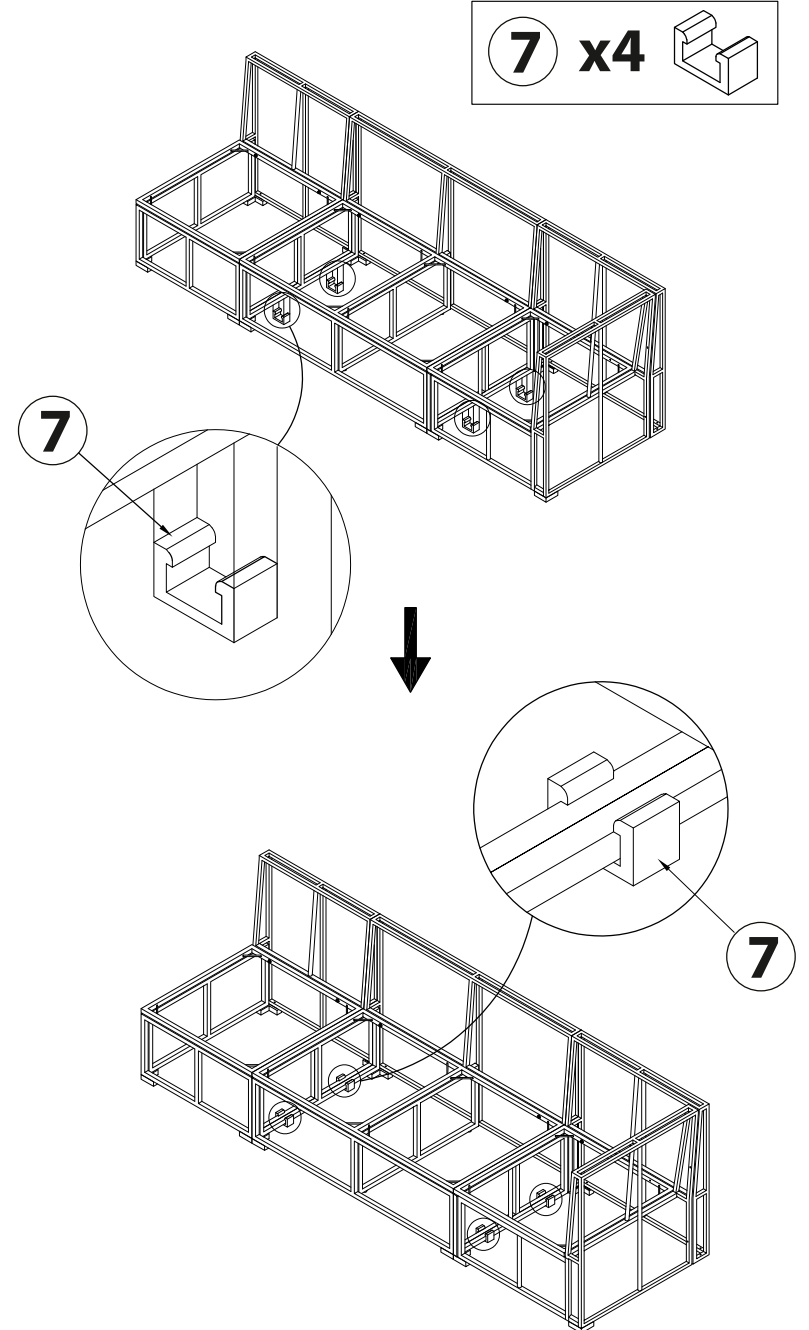

Wicker Sectional Sofa Set

Dist. by TDC USA, Inc. Fairfield, NJ 07004
©2021 All Rights Reserved. Made in Vietnam.

Item #21746

Questions and Comments
1-800-599-8898 (9 am - 5 pm EST)
www.tdcusainc.com