

Wicker Patio Conversation Set



Assembly Instructions

Made in Vietnam

The owner's manual contains important safety information as well as assembly, use and maintenance instructions. Keep the packaging and bags away from children and dispose of all packaging properly before use. Keep this manual for future reference.



**PLEASE DO NOT
RETURN THIS
PRODUCT
TO THE STORE**

We will be happy to correct any problems that you may have, or answer any of your questions regarding the purchase of this product. Please contact us at our Toll Free customer service number 1-800-599-8898 for any assistance and replacement parts. Thank You.

Dist. by TDC USA, Inc. Fairfield, NJ 07004
©2021 All Rights Reserved.
Made in Vietnam
Item 22561
www.tdcusainc.com

⚠ WARNING!

- **Keep all children and pets away from assembly area. Children and pets should be supervised when they are in the area of the product construction.**
- **Some parts may contain sharp edges. When assembling and using this product, basic safety precautions should always be.**
- **Please read all the instructions and warnings before assembling. In order to make the whole product adjust to the best, please install all the screws on the product and tighten all the screws after adjusting the product which can stand on the floor even. Not intended for commercial use.**
- **Check all bolts for tightness before use.**
- **IMPORTANT - check and tighten bolts often to keep them secure**

• **CHOKING HAZARD** - Small parts. Not suitable for children under 36 months. The product contains small parts, keep children away when assembling.

• **ADULT ASSEMBLY REQUIRED.**
Always remove protective material and poly bags and dispose before assembly.

A (x2) Table Leg	B (x1) Table Shelf	C (x1) Table Rim
D (x1) Glass	E (x3) Armrest	F (x3) Armrest
G (x1) Sofa Back	H (x1) Sofa Seat	I (x1) Sofa Panel
J (x2) Chair Back	K (x2) Chair Seat	L (x2) Chair Panel
1 (x2) M6x15 Bolt	2 (x20) M6x30 Bolt	3 (x47) Washer
4 (x4) Hex Key	5 (x25) M6x35 Bolt	

Table Assembly

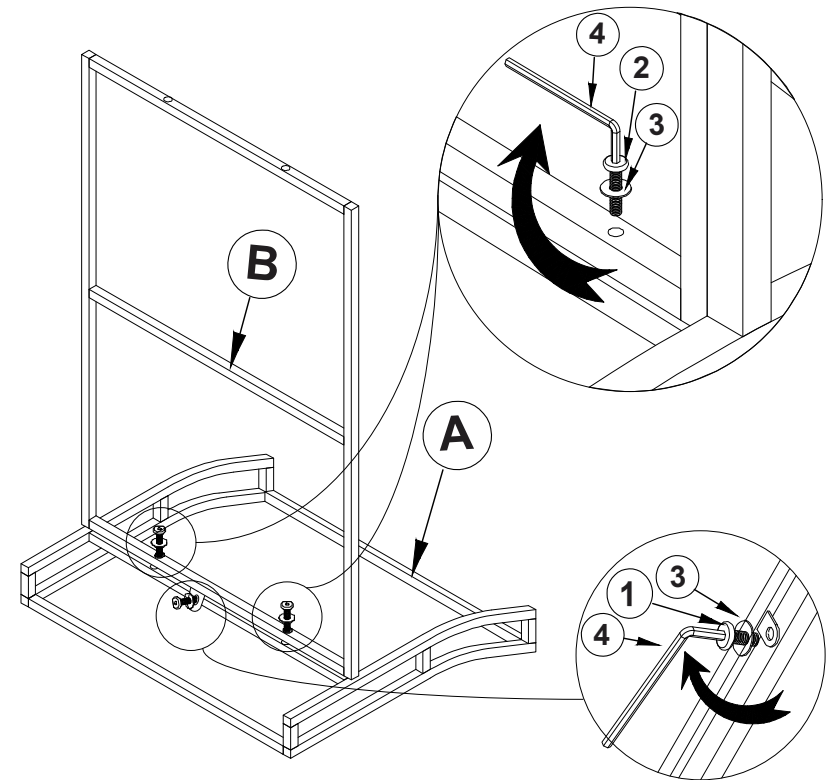

Step 1:

Set one Table Leg (A) on a soft, non-abrasive surface.

Place one end of Table Shelf (B) against it so that the top is facing in the direction of the curved end of Table Leg (A). Insert two M6x30 Bolts (2) with Washers (3) through the eyelets at the end of Table Shelf (B) and into the bolt-threading found on the side of the center bar of Table Leg (A). **Do not tighten bolts all the way until all parts have been assembled.**

Insert one M6x15 Bolt (1) with Washer (3) through bracket at the end of Table Shelf (B) and into the bolt-threading found underneath the center bar of Table Leg (A).

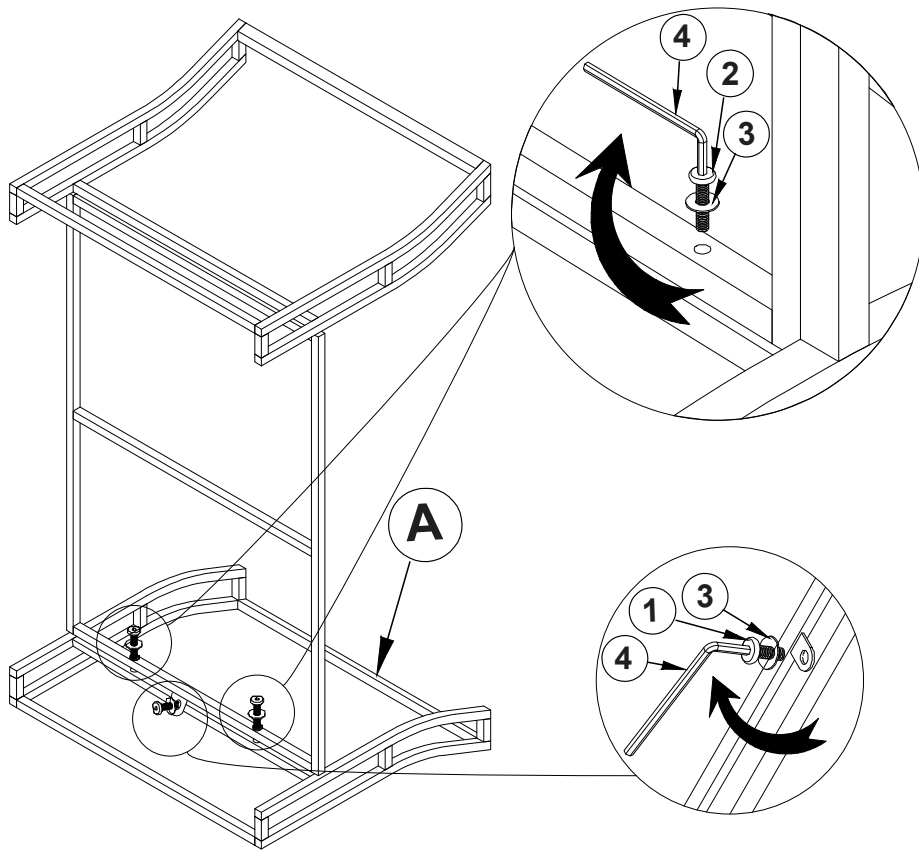

Step 2:

Set the second Table Leg (A) on a soft, non-abrasive surface.

Place opposite end of Table Shelf (B) against it so that the top is facing in the direction of the curved end of Table Leg (A). Insert two M6x30 Bolts (2) with Washers (3) through the eyelets at the end of Table Shelf (B) and into the bolt-threading found on the side of the center bar of Table Leg (A).

Insert one M6x15 Bolt (1) with Washer (3) through bracket at the end of Table Shelf (B) and into the bolt-threading found underneath the center bar of Table Leg (A).

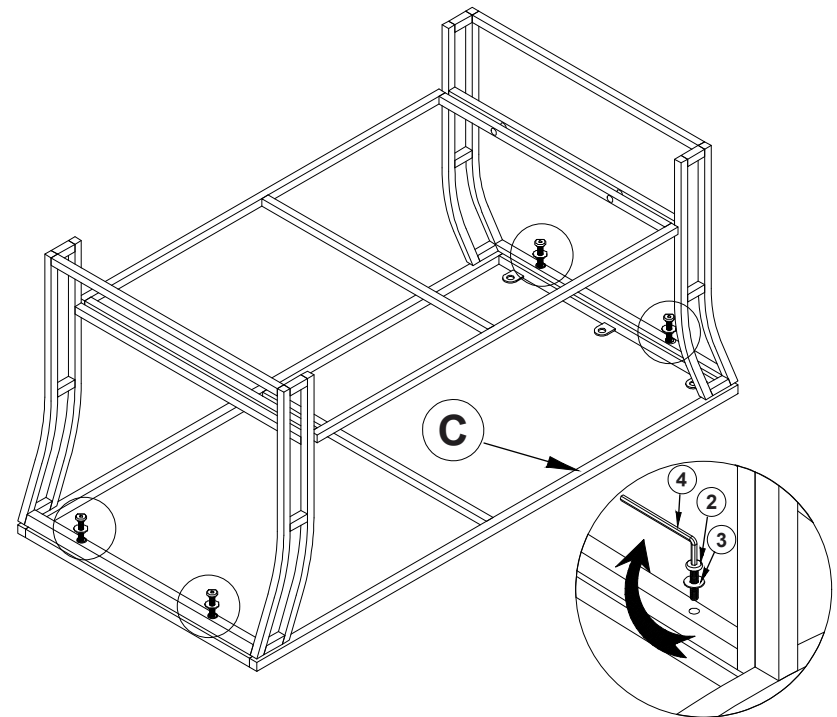

Step 3:

Remove Glass (D) from Table Rim (C) carefully and set it aside until assembly is complete. Set Table Rim (C) upside-down on a soft, non-abrasive surface. Place the previously assembled parts on top as illustrated here.

Insert two M6x30 Bolts (2) with Washers (3) through the eyelets at the top of Table Leg (A) and into the bolt-threading found underneath Table Rim (C). Follow this step to connect the second Table Leg (A) to the opposite end of Table Rim (C). Tighten all bolts left loose throughout assembly process using Hex Key (4).

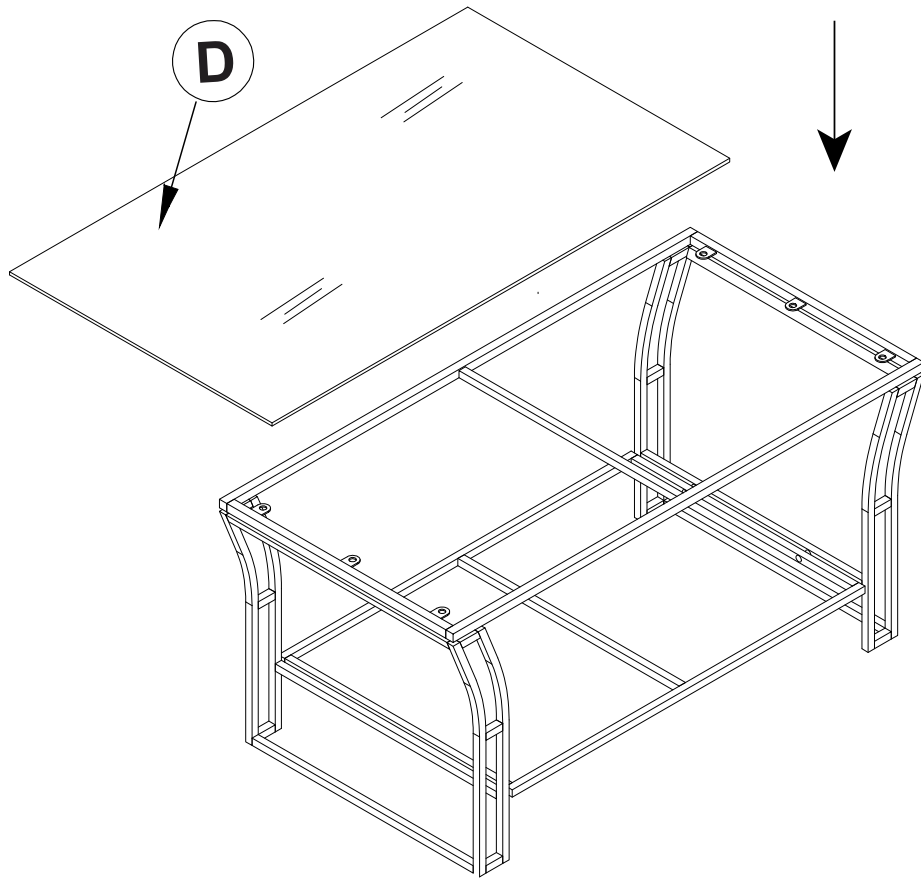

Step 4:

Turn table right-side up and carefully set Glass (D) into the center of Table Rim (C). The table is now ready to use.

Chair Assembly

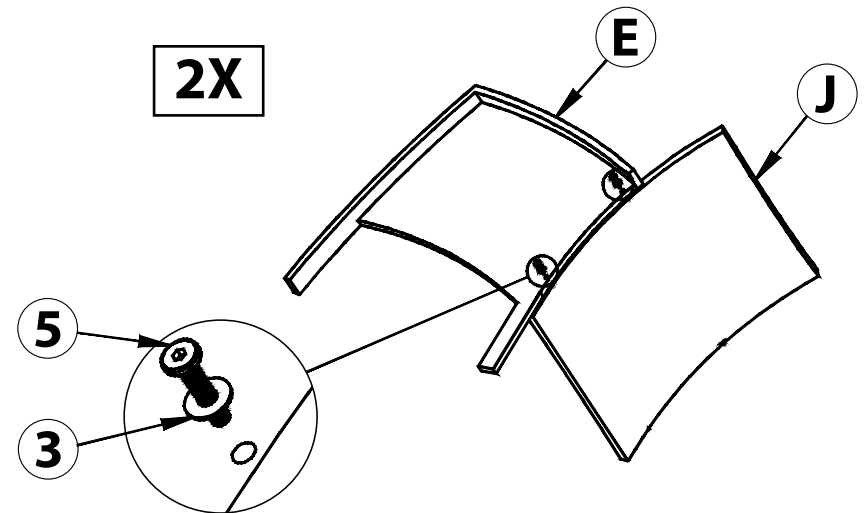

Step 1:

Insert two M6x35 Bolts (5) with Washers (3) through the back end of Armrest (E) and into the left side of Chair Back (J). **Do not tighten bolts all the way until all parts have been assembled.**

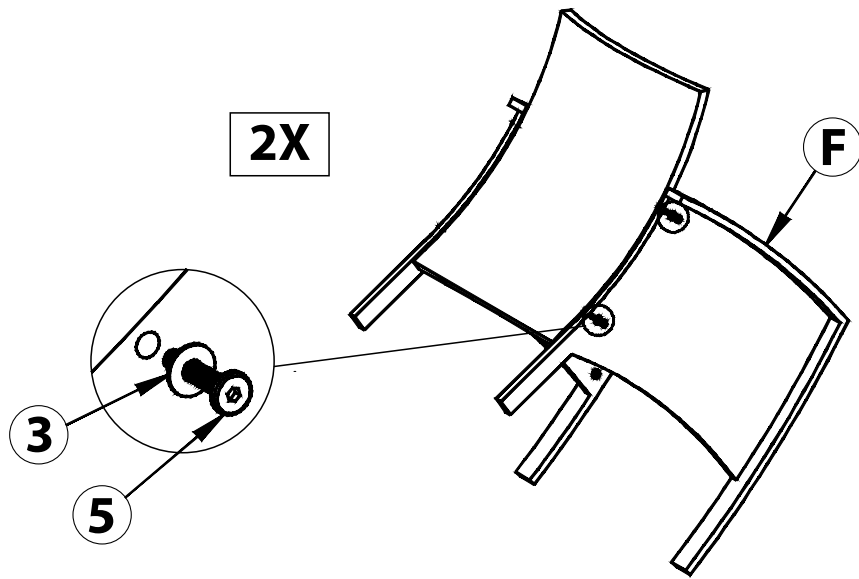

Step 2:

Insert two M6x35 Bolts (5) with Washers (3) through the back end of Armrest (F) and into the right side of Chair Back (J).

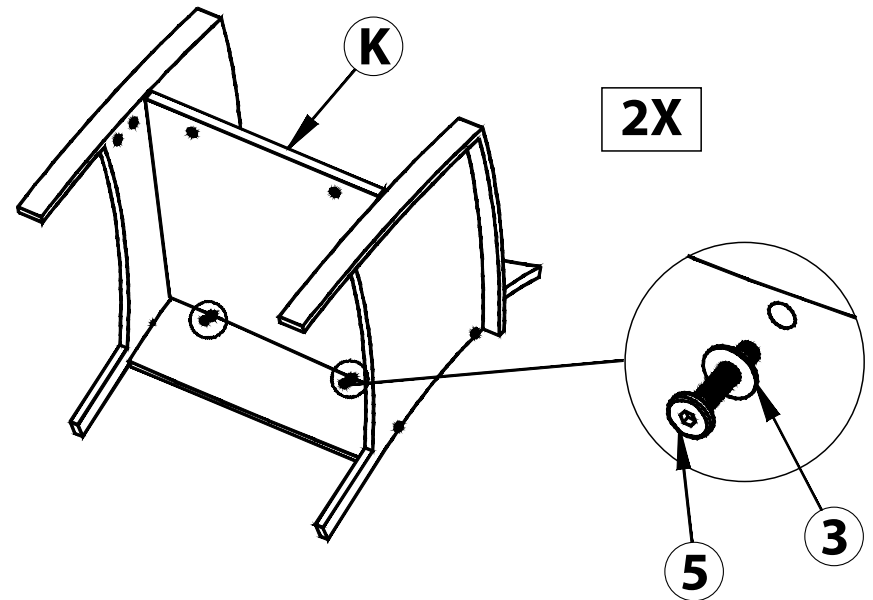

Step 3:

Place Chair Seat (K) in between both armrests. Insert two M6x35 Bolts (5) with Washers (3) through brackets near the bottom of Chair Back (J) and into the bolt-threading underneath Chair Seat (K).

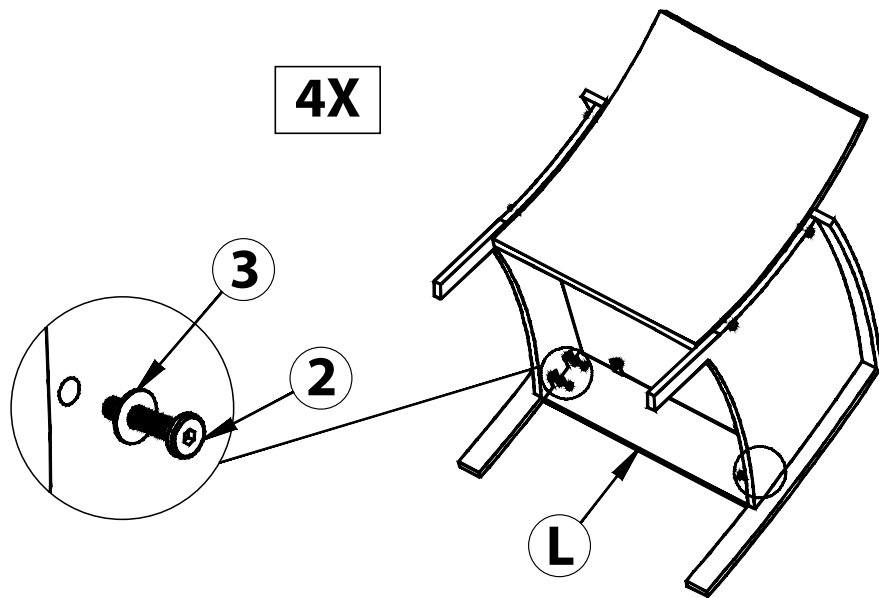

Step 4:

Place Chair Panel (L) in between the front of both armrests and underneath Chair Seat (K). Insert two M6x30 Bolts (2) with Washers (3) through brackets at both ends of Chair Panel (L) and into the bolt-threading found at the front of both Armrests (E & F).

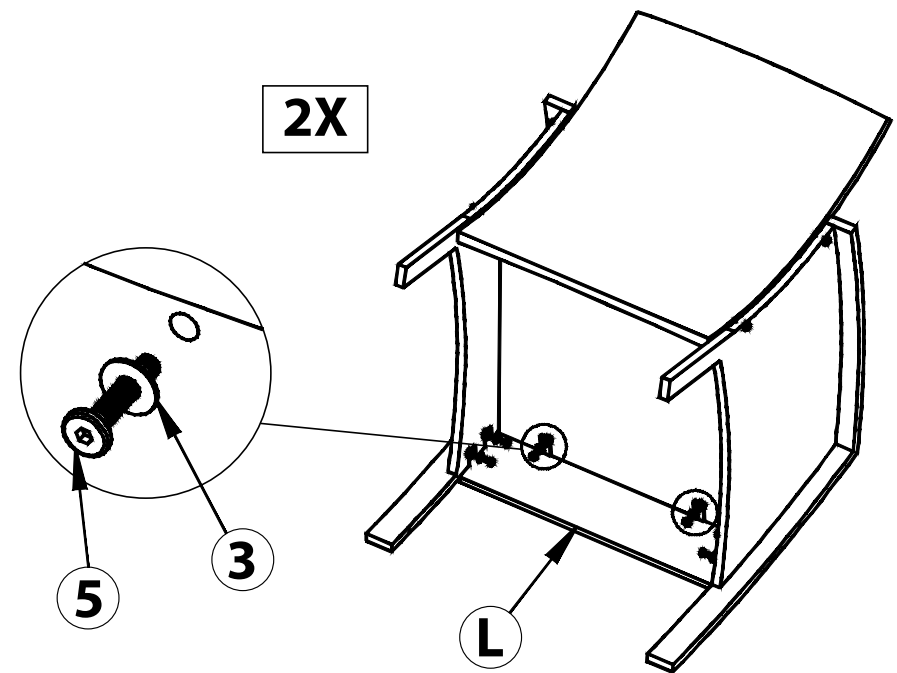

Step 5:

Insert two M6x35 Bolts (5) with Washers (3) through brackets at the top of Chair Panel (L) and into the bolt-threading found at the front end of Chair Seat (K). Tighten all bolts left loose through assembly process using Hex Key (4).

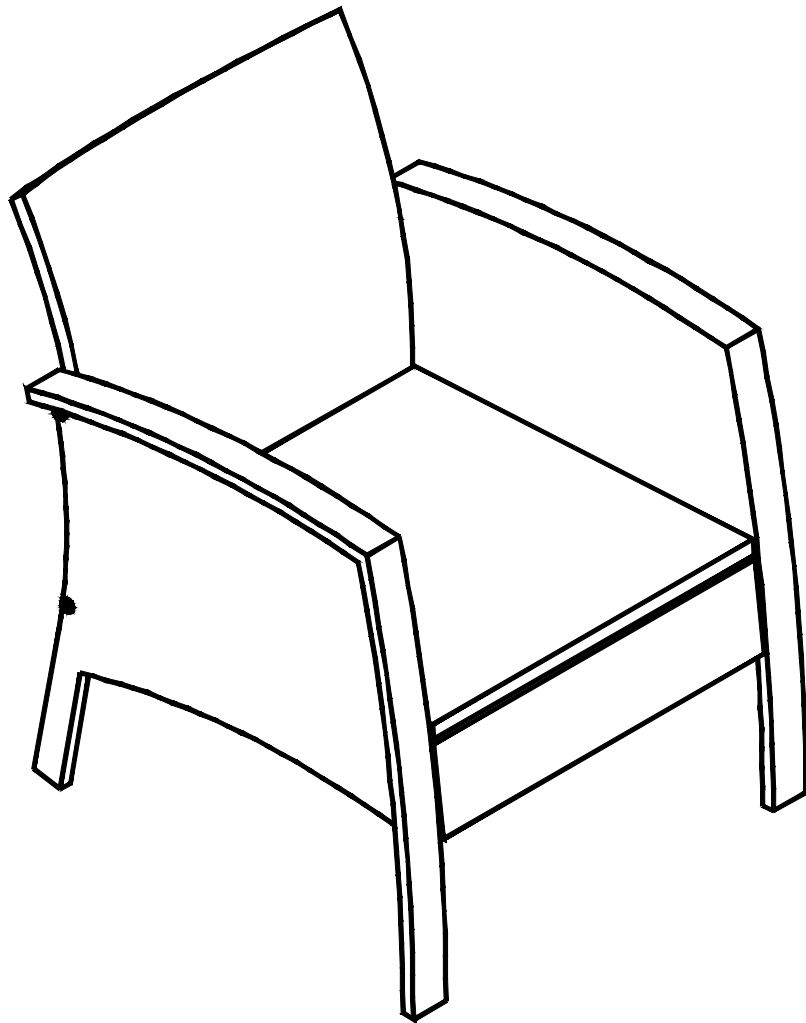

Step 6:

Turn chair right-side up and set a chair cushion over Chair Seat (K). The chair is now ready to use.

**Sofa
Assembly**

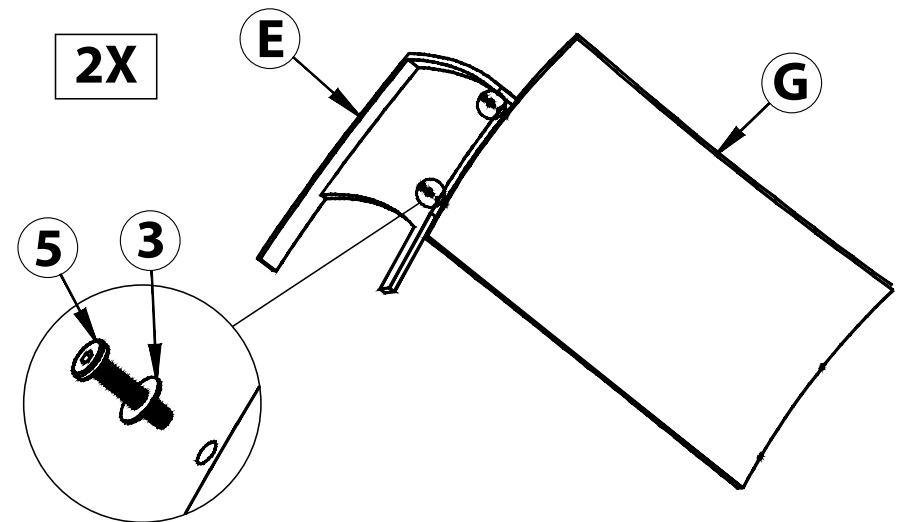

Step 1:

Insert two M6x35 Bolts (5) with Washers (3) through the back end of Armrest (E) and into the left side of Sofa Back (G). **Do not tighten bolts all the way until all parts have been assembled.**

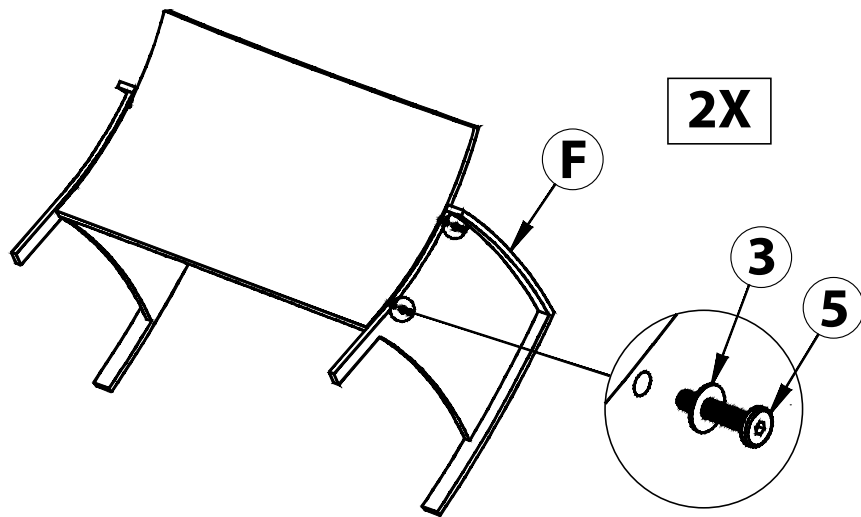

Step 2:

Insert two M6x35 Bolts (5) with Washers (3) through the back end of Armrest (F) and into the right side of Sofa Back (G).

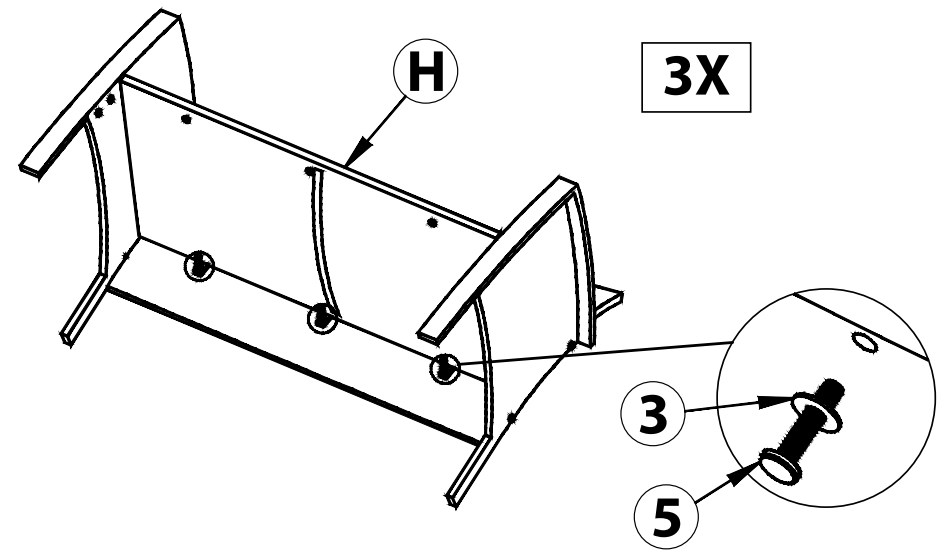

Step 3:

Place Sofa Seat (H) in between both armrests. Insert three M6x35 Bolts (5) with Washers (3) through brackets near the bottom of Sofa Back (G) and into the bolt-threading underneath Sofa Seat (H).

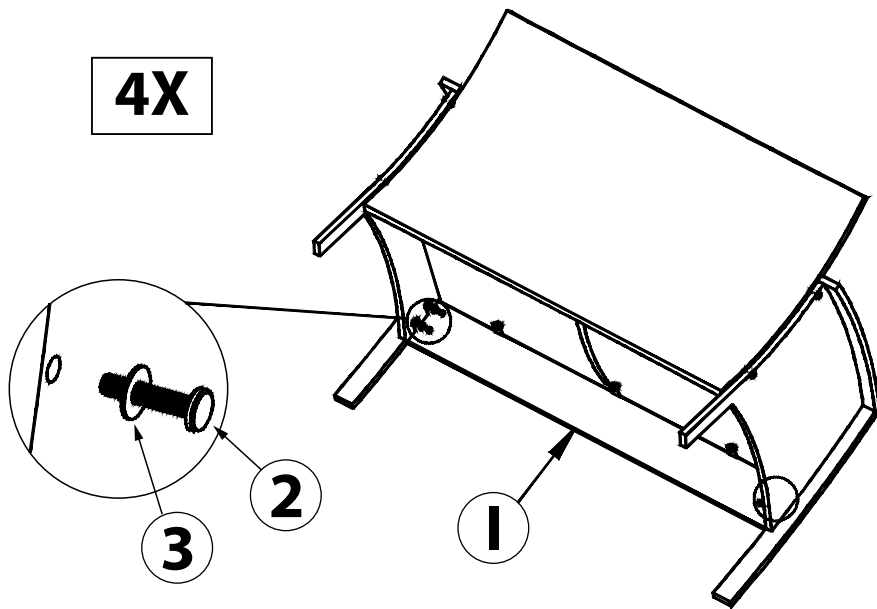

Step 4:

Place Sofa Panel (I) in between the front of both armrests and underneath Sofa Seat (G). Insert two M6x30 Bolts (2) with Washers (3) through brackets at both ends of Sofa Panel (I) and into the bolt-threading found at the front of both Armrests (E & F).

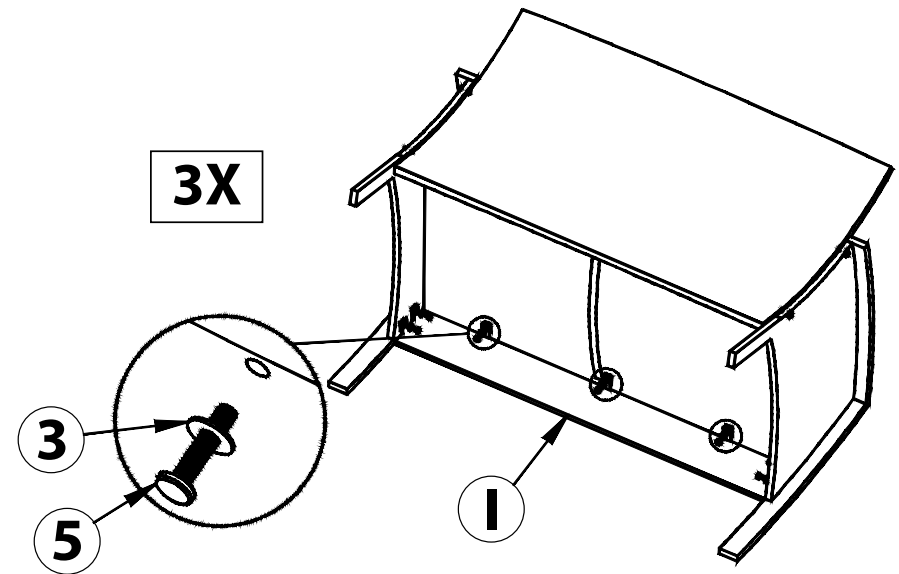

Step 5:

Insert three M6x35 Bolts (5) with Washers (3) through brackets at the top of Sofa Panel (I) and into the bolt-threading found at the front end of Sofa Seat (G). Tighten all bolts left loose through assembly process using Hex Key (4).

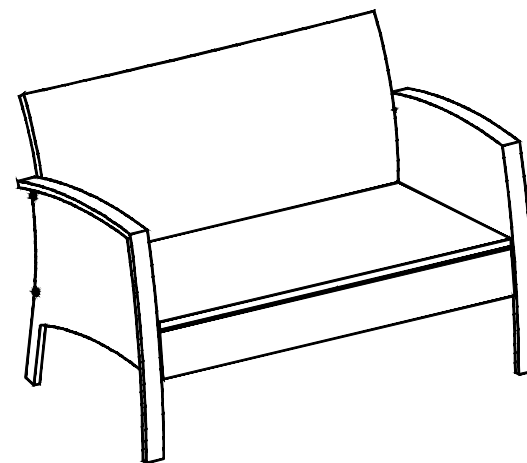

Step 6:

Turn sofa right-side up and set the sofa cushion over Sofa Seat (H). The sofa is now ready to use.

Wicker Patio Conversation Set

Dist. by TDC USA, Inc. Fairfield, NJ 07004
©2021 All Rights Reserved. Made in Vietnam.

Item #22561

Questions and Comments
1-800-599-8898 (9 am - 5 pm EST)
www.tdcusainc.com