

4 Piece Sofa Set

Steel Frame with Powder Coating



Assembly Instructions

Made in China

The owner's manual contains important safety information as well as assembly, use and maintenance instructions. Keep the packaging and bags away from children and dispose of all packaging properly before use. Keep this manual for future reference.



**PLEASE DO NOT
RETURN THIS
PRODUCT
TO THE STORE**

We will be happy to correct any problems that you may have, or answer any of your questions regarding the purchase of this product. Please contact us at our Toll Free customer service number 1-800-599-8898 for any assistance and replacement parts. Thank You.

Dist. by TDC USA, Inc. Fairfield, NJ 07004

©2020 All Rights Reserved.

Made in China

Item 21637

www.tdcusainc.com











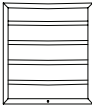
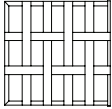
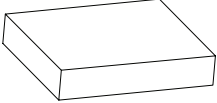

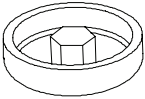
**WARNING!**

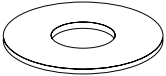
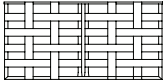
- **Keep all children and pets away from assembly area. Children and pets should be supervised when they are in the area of the product construction.**
- **Some parts may contain sharp edges. When assembling and using this product, basic safety precautions should always be.**
- **Please read all the instructions and warnings before assembling. In order to make the whole product adjust to the best, please install all the screws on the product and tighten all the screws after adjusting the product which can stand on the floor even. Not intended for commercial use.**
- **Check all bolts for tightness before use.**
- **IMPORTANT - check and tighten bolts often to keep them secure**

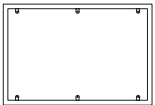
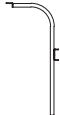
• **CHOKING HAZARD** - Small parts. Not suitable for children under 36 months. The product contains small parts, keep children away when assembling.

• **ADULT ASSEMBLY REQUIRED.**

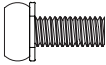
Always remove protective material and poly bags and dispose before assembly.

 <p>A (x6) Arm Rest</p>	 <p>C (x2) Chair Back</p>	 <p>D (x2) Chair Seat</p>
 <p>E (x4) Seat Cushion</p>	 <p>F (x4) Back Cushion</p>	 <p>G (x2) Throw Pillow</p>
 <p>H (x36) Screw Cover</p>	 <p>I (x4) M6x35 Screw</p>	 <p>J (x24) M6x40 Screw</p>
 <p>K (x36) Washer</p>	 <p>L (x1) Sofa Seat</p>	 <p>M (x1) Sofa Back</p>
 <p>N (x1) Table Rim</p>	 <p>O (x4) Table Leg</p>	 <p>P (x1) Table Ring</p>
 <p>Q (x1) Glass</p>	 <p>R (x4) M6x25 Screw</p>	 <p>S (x4) M6x15 Screw</p>
 <p>AA (x3) Hex Key</p>		

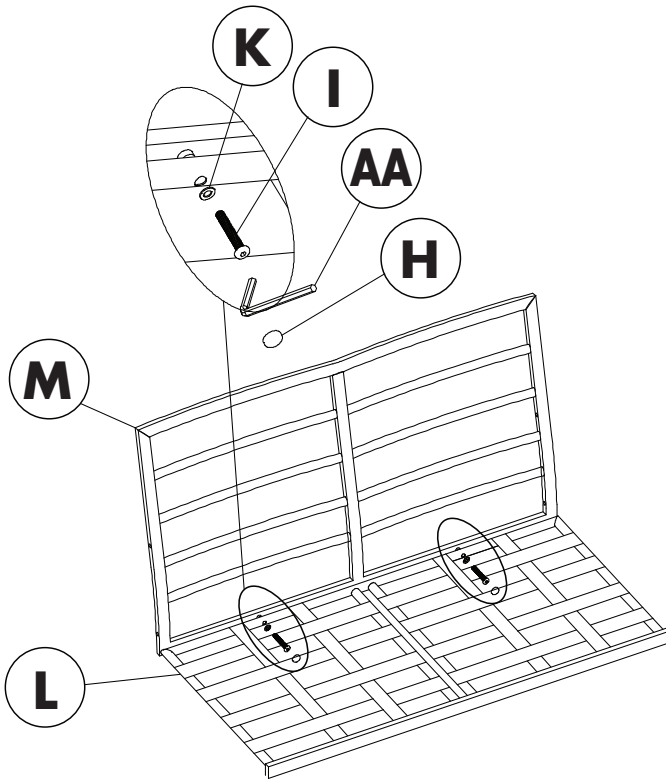

Step 1:

Set Sofa Seat (L) down with the straps facing up. Place the bottom of Sofa Back (M) against the back end of Sofa Seat (L) to form an "L" shape. Insert two Screws M6x35 (I) through Washer (K) and then through the screw holes of Sofa Seat (L) and into Sofa Back (M). Do not tighten fully.

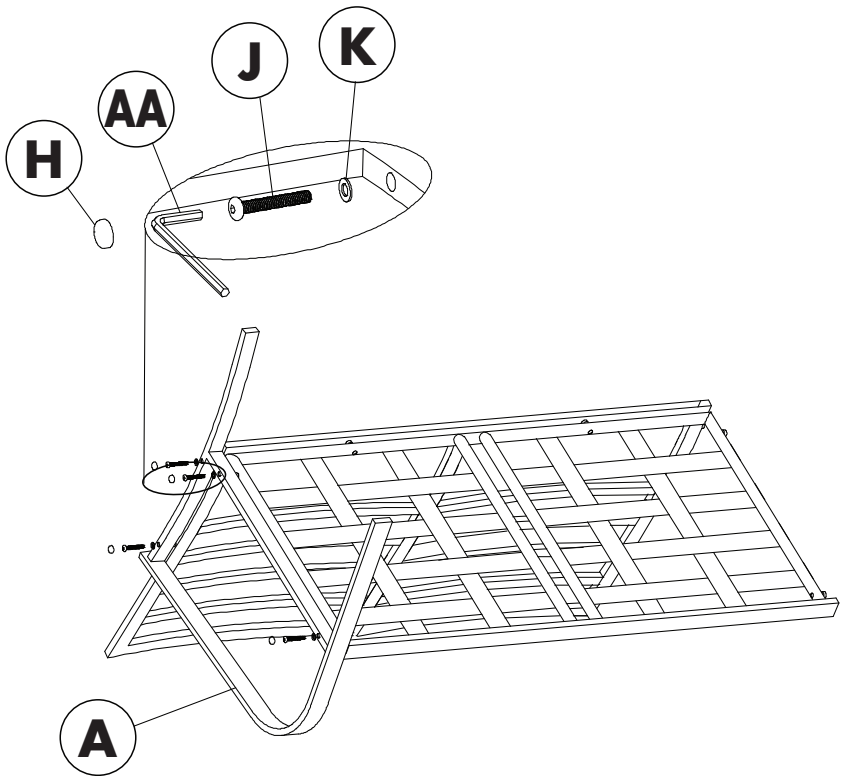

Step 2:

Turn the sofa seat/back just assembled upside down and place one Arm Rest (A) against it. The legs of Arm Rest (A) should be pointing away from the bottom of Sofa Seat (L). Insert two Screws M6x40 (J) through Washers (K) and then through the screw holes of Arm Rest (A) and into Sofa Back (M). Insert two Screws M6x40 (J) through Washers (K) and then through the screw holes of Arm Rest (A) and into Sofa Seat (L). Do not tighten fully.

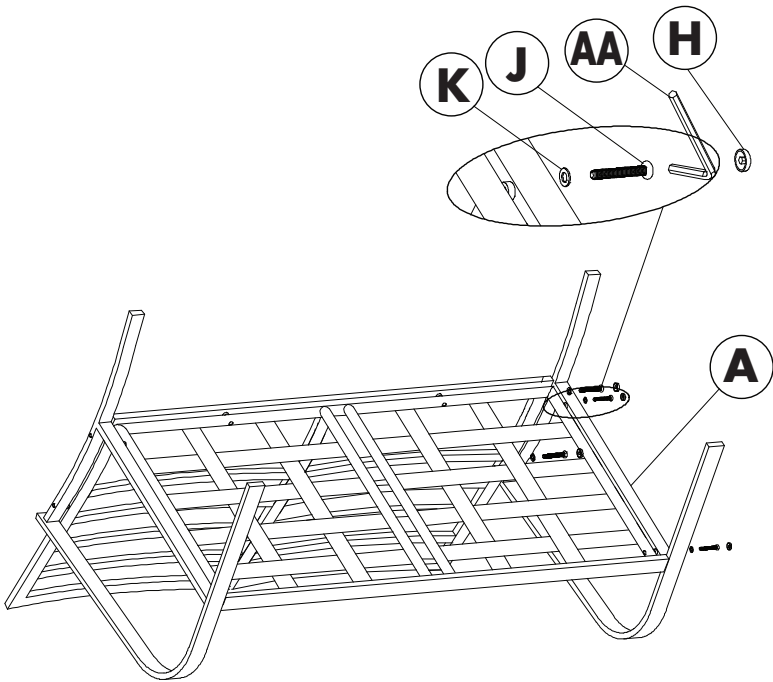

Step 3:

Place second Arm Rest (A) on opposite side of sofa seat/back and follow the same instructions provided in Step 2. Once Arm Rest (A) is in place, tighten all loose screws completely. Place Screw Covers (H) over all screw heads.

Step 4:

Place Seat Cushions (E) and Back Cushions (F) in their designated places (G) and use the Throw Pillows (G) as needed.

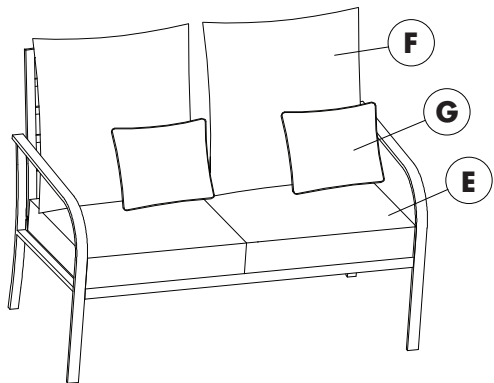

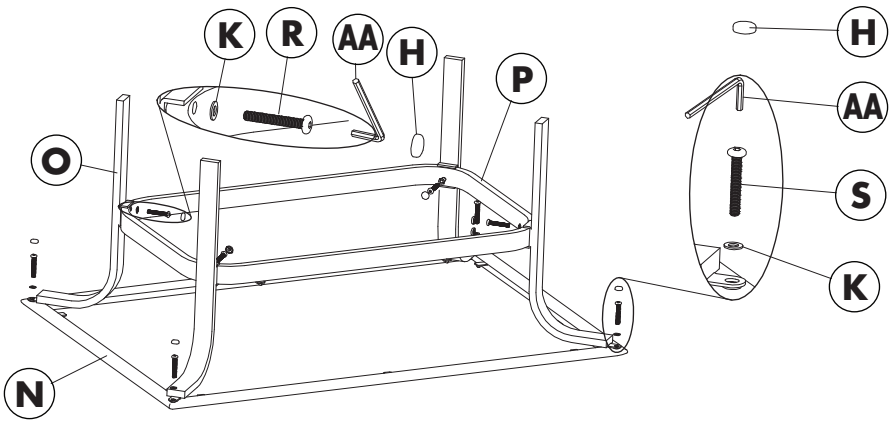

Step 1:

Remove Glass (Q) from Table Rim (N). Lay Table Rim (N) upside down. Using four Screws M6x15 (S) and Washers (K), screw the Legs (O) to the Table Rim (N). Screw the Table Ring (P) onto the Legs (O) using Screws M6x25 (R) and Washers (K). Once Table Ring (P) is in place, tighten all loose screws completely. Place Screw Covers (H) over all screw heads to hide their appearance.

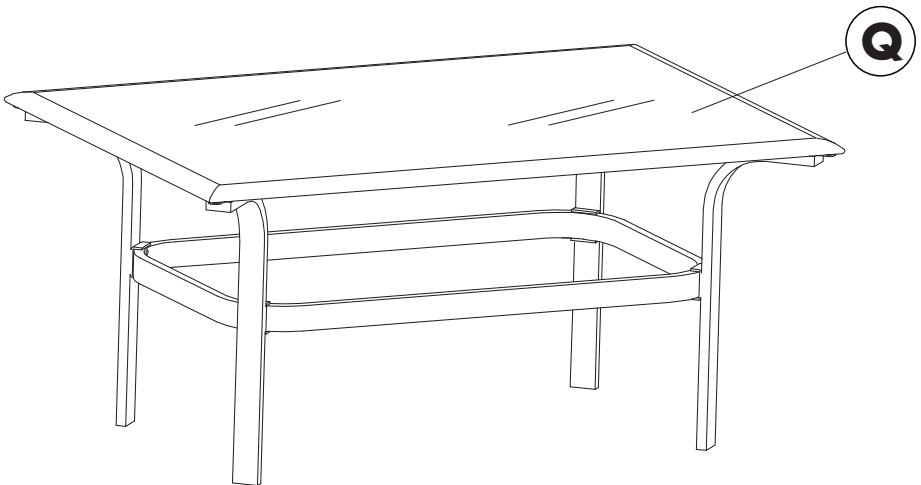

Step 2:

Turn table right-side up and put Glass (Q) back into place inside Table Rim (N).

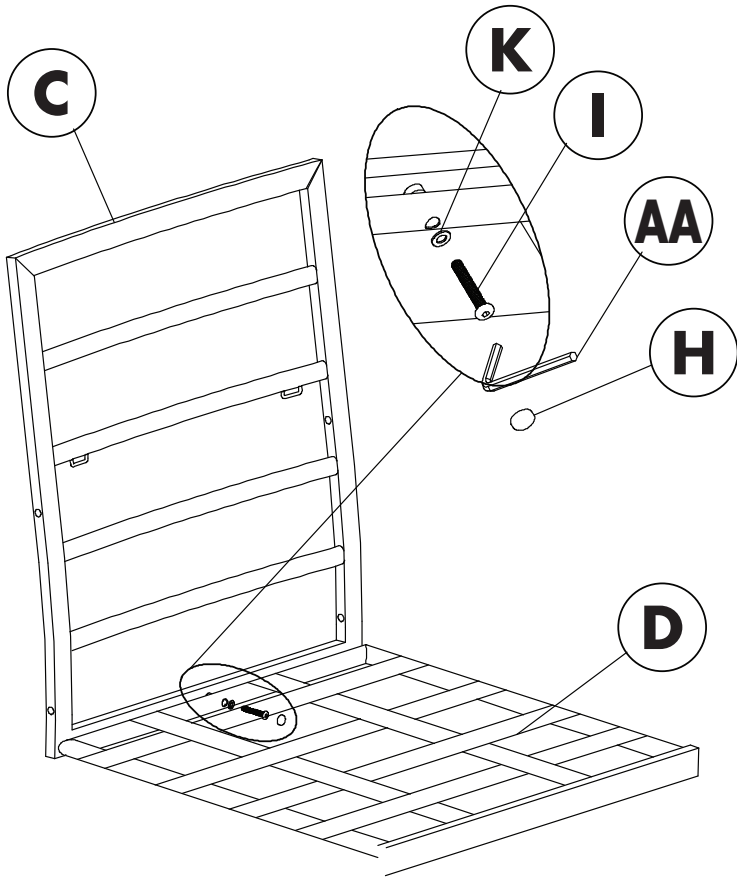

Step 1:

Set Chair Seat (D) down with the straps facing up. Place the bottom of Chair Back (C) against the back end of Chair Seat (D) to form an "L" shape. Insert one Screws M6x35 (I) through Washers (K) and then through the screw hole of Chair Seat (D) and into Chair Back (C). Do not tighten fully.

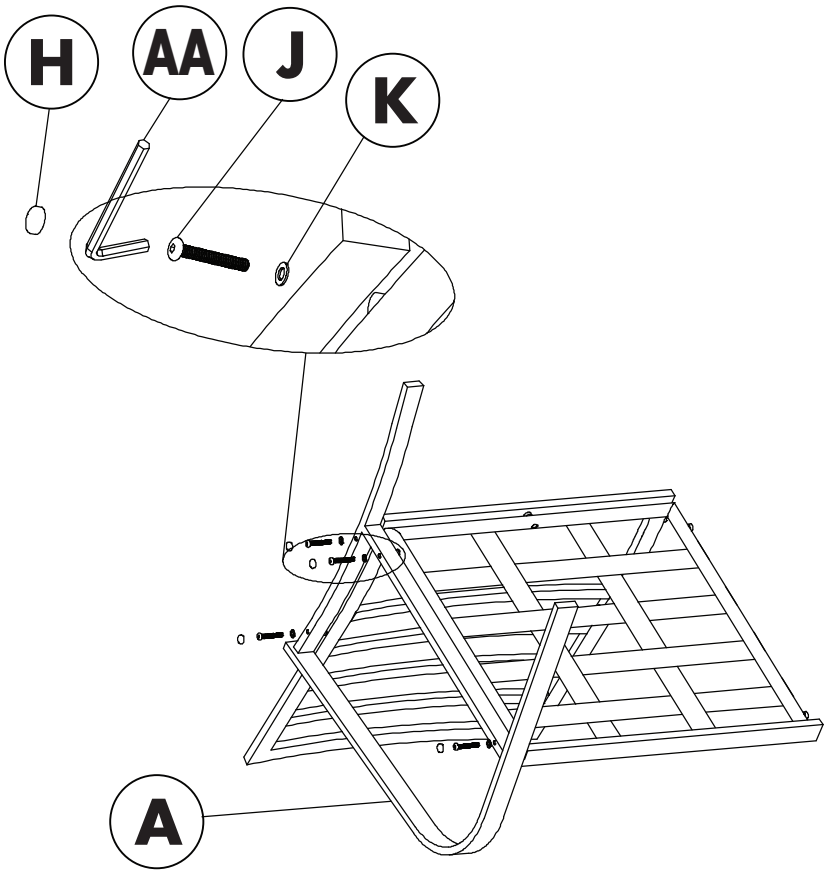

Step 2:

Turn the chair seat/back just assembled upside down and place one Arm Rest (A) against it. The legs of Arm Rest (A) should be pointing away from the bottom of Chair Seat (D). Insert two Screws M6x40 (J) through Washers (K) and then through the screw holes of Arm Rest (A) and into Chair Back (C). Insert two Screws M6x40 (J) through Washers (K) and then through the screw holes of Arm Rest (A) and into Chair Seat (D). Do not tighten fully.

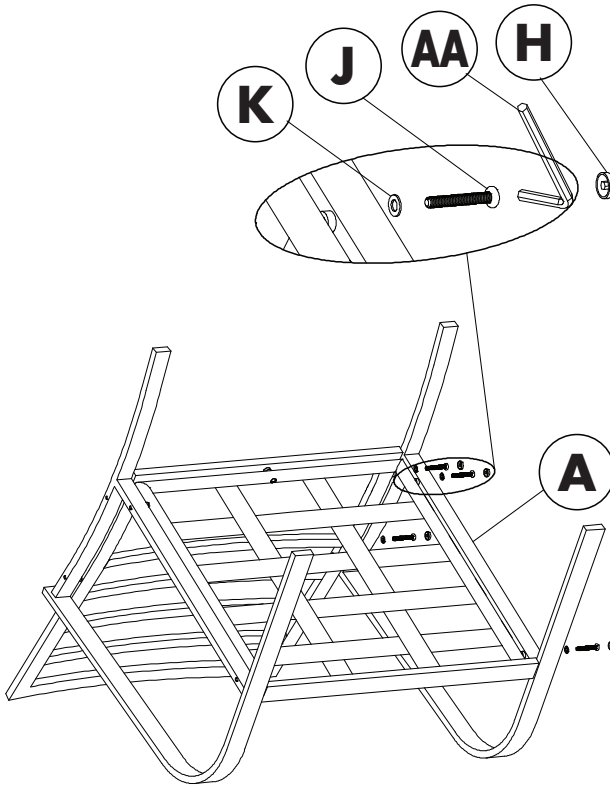

Step 3:

Place second Arm Rest (A) on opposite side of chair seat/back and follow the same instructions provided in Step 2. Once Arm Rest (A) is in place, tighten all loose screws completely. Place Screw Covers (H) over all screw heads to hide their appearance.

Step 4:

Place Seat Cushions (E) and Back Cushions (F) in their designated places.

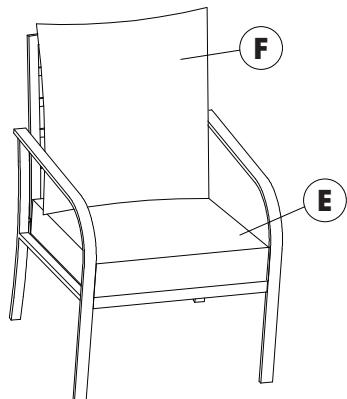

4 Piece Sofa Set

Steel Frame with Powder Coating

Dist. by TDC USA, Inc. Fairfield, NJ 07004
©2020 All Rights Reserved. Made in China.

Item #21637

Questions and Comments

1-800-599-8898 (9 am - 5 pm EST)

www.tdcusainc.com