

3 Piece Wicker Set with Chaise

Steel Frame with Powder Coating



Assembly Instructions

Made in Vietnam

The owner's manual contains important safety information as well as assembly, use and maintenance instructions. Keep the packaging and bags away from children and dispose of all packaging properly before use. Keep this manual for future reference.



**PLEASE DO NOT
RETURN THIS
PRODUCT
TO THE STORE**

We will be happy to correct any problems that you may have, or answer any of your questions regarding the purchase of this product. Please contact us at our Toll Free customer service number 1-800-599-8898 for any assistance and replacement parts. Thank You.

Dist. by TDC USA, Inc. Fairfield, NJ 07004

©2021 All Rights Reserved.

Made in Vietnam

Item 21955

www.tdcusainc.com

**WARNING!**



- **Keep all children and pets away from assembly area. Children and pets should be supervised when they are in the area of the product construction.**
- **Some parts may contain sharp edges. When assembling and using this product, basic safety precautions should always be.**
- **Please read all the instructions and warnings before assembling. In order to make the whole product adjust to the best, please install all the screws on the product and tighten all the screws after adjusting the product which can stand on the floor even. Not intended for commercial use.**
- **Check all bolts for tightness before use.**
- **IMPORTANT - check and tighten bolts often to keep them secure**

• **CHOKING HAZARD** - Small parts. Not suitable for children under 36 months. The product contains small parts, keep children away when assembling.

• **ADULT ASSEMBLY REQUIRED.**

Always remove protective material and poly bags and dispose before assembly.

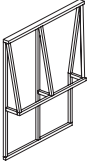
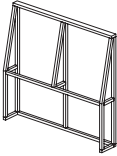
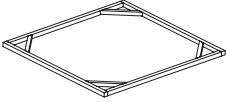
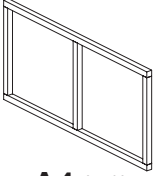
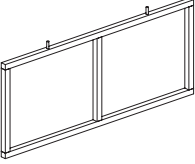
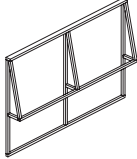
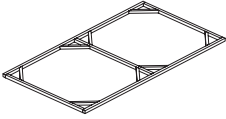
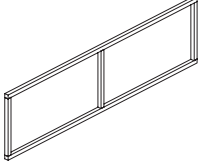
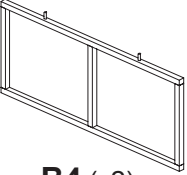
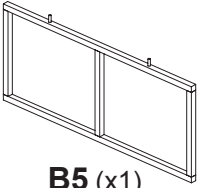
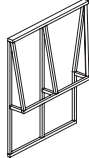
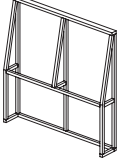
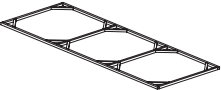
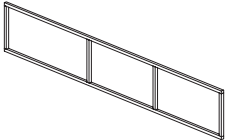
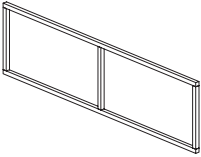
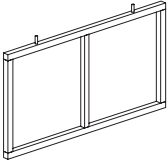
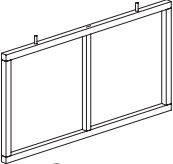
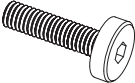
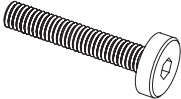
Parts | 4

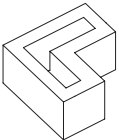
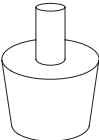
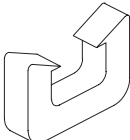
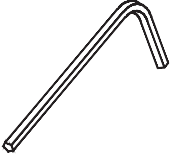
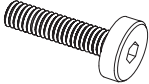
 <p>A1 (x1) Right Chair Back</p>	 <p>A2 (x1) Left Chair Back</p>	 <p>A3 (x1) Chair Seat</p>	 <p>A4 (x1) Left Chair Panel</p>	
 <p>A5 (x1) Right Chair Panel</p>	 <p>B1 (x1) Sofa Back</p>	 <p>B2 (x1) Sofa Seat</p>	 <p>B3 (x1) Sofa Front Panel</p>	
 <p>B4 (x2) Sofa Panel</p>	 <p>B5 (x1) Support</p>	 <p>C1 (x1) Right Chaise Back</p>	 <p>C2 (x1) Left Chaise Back</p>	
 <p>C3 (x1) Chaise Seat</p>	 <p>C4 (x1) Chaise Long Panel</p>	 <p>C5 (x1) Chaise Short Panel</p>	 <p>C6 (x1) Chaise Panel</p>	
 <p>C7 (x2) Support</p>	 <p>1 (x38) M6x35 Bolt</p>	 <p>2 (x1) M6x55 Bolt</p>	 <p>3 (x39) Washer</p>	
 <p>4 (x13) Corner Foot</p>	 <p>5 (x6) Foot</p>	 <p>6 (x4) Clamp</p>	 <p>7 (x2) Hex Key</p>	 <p>8 (x26) M6x25 Bolt</p>

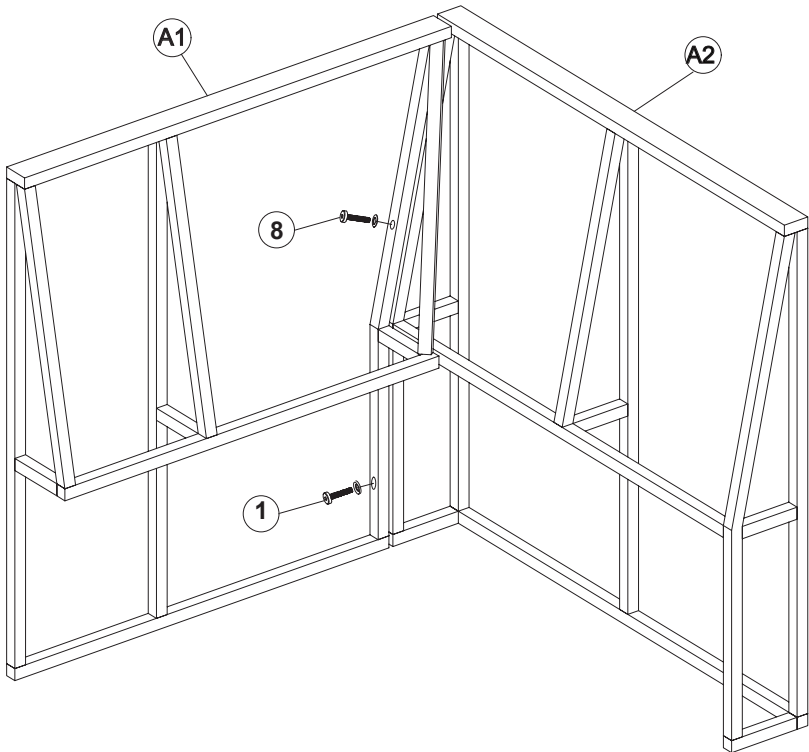

Step 1:

Bring Right Chair Back (A1) and Left Chair Back (A2) together as illustrated here. Insert one M6x35 Bolt (1) with Washer (3) through the bottom of Right Chair Back (A1) and into bolt-threading found on Left Chair Back (A2). Do not tighten bolts all the way until all parts have been assembled. Insert one M6x35 Bolt (8) with Washer (3) through the top of Right Chair Back (A1) and into bolt-threading found on Left Chair Back (A2).

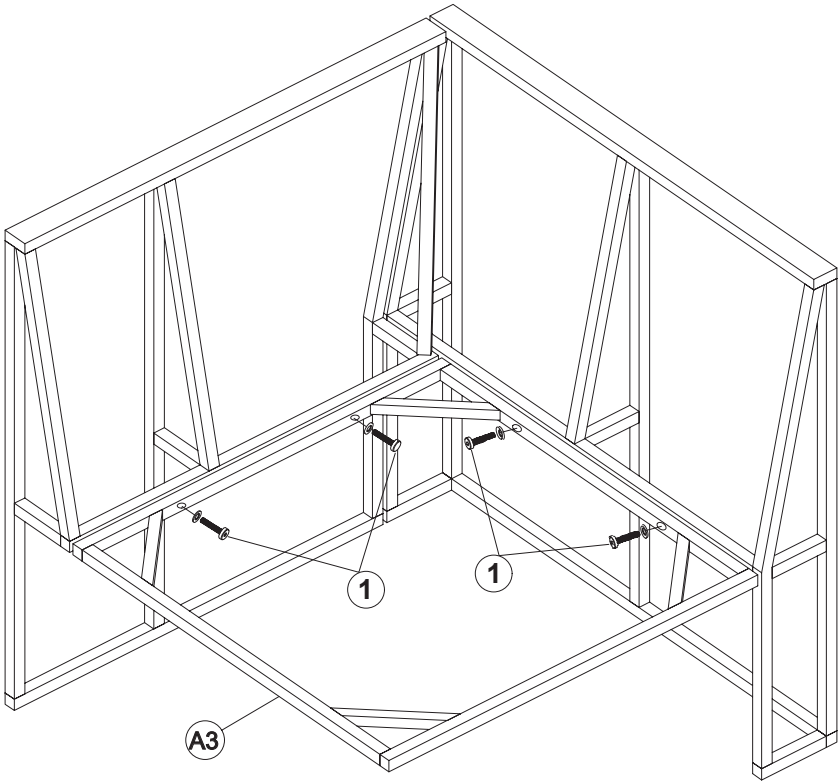

Step 2:

Insert two M6x35 Bolts (1) with Washers (3) through the bottom of Chair Seat (A3) and into bolt-threading found at the bottom of the chair back of A1. Insert two M6x35 Bolts (1) with Washers (3) through the bottom of Chair Seat (A3) and into bolt-threading found at the bottom of the chair back of A2.

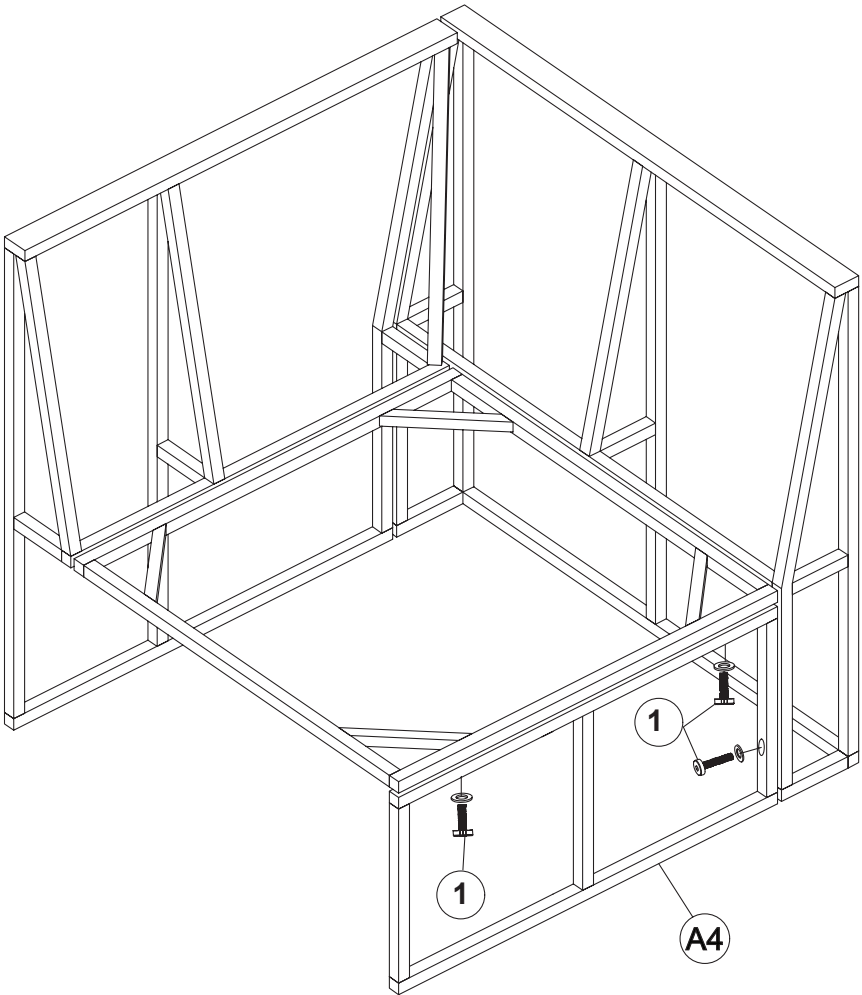

Step 3:

Place Left Chair Panel (A4) underneath the side of Chair Seat (A3) and against Left Chair Back (A2) as illustrated here. Insert two M6x35 Bolts (1) with Washers (3) through the top of Left Chair Panel (A4) and into the bolt-threading found underneath Chair Seat (A3). Insert one M6x35 Bolt (1) with Washer (3) through the side of Left Chair Panel (A4) and into the bolt-threading found at the bottom of Left Chair Back (A2).

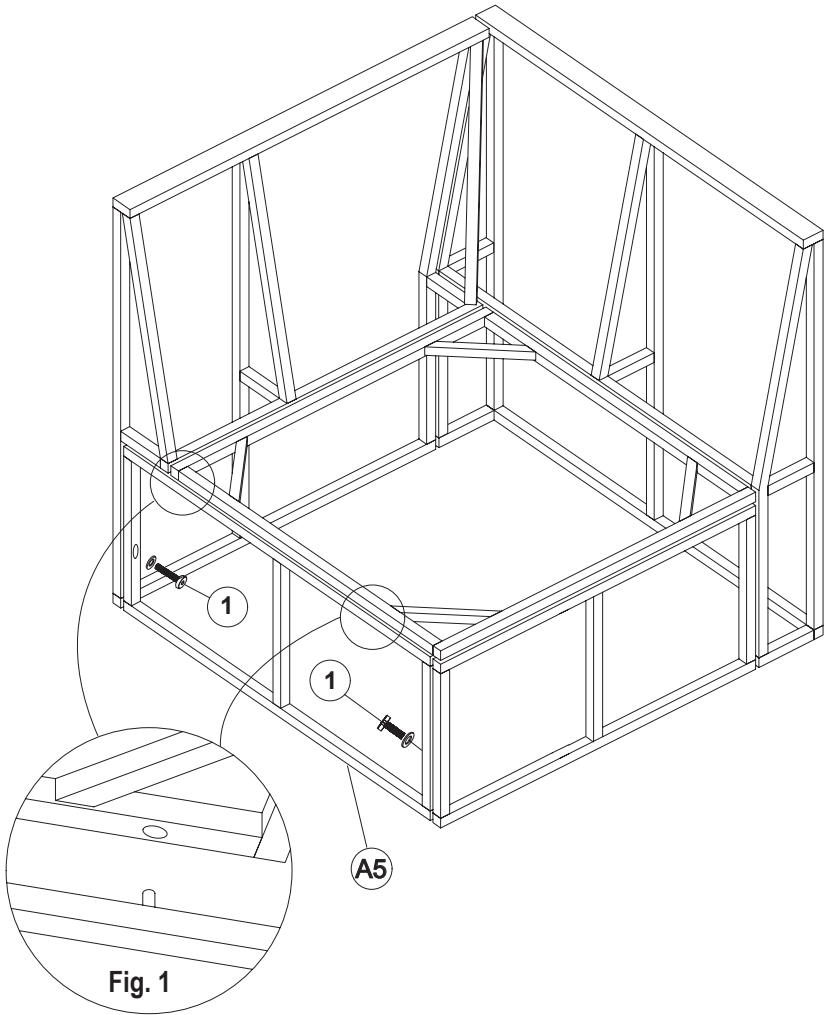

Step 4:

Insert pegs found at the top of Right Chair Panel (A5) into eyelets found underneath the side of Chair Seat (A3); see Figure 1. Insert one M6x35 Bolt (1) with Washer (3) through the side of Right Chair Panel (A5) and into the bolt-threading found at the bottom of Right Chair Back (A1). Insert one M6x35 Bolt (1) with Washer (3) through the side of Right Chair Panel (A5) and into the bolt-threading found on the side of Left Chair Panel (A4).

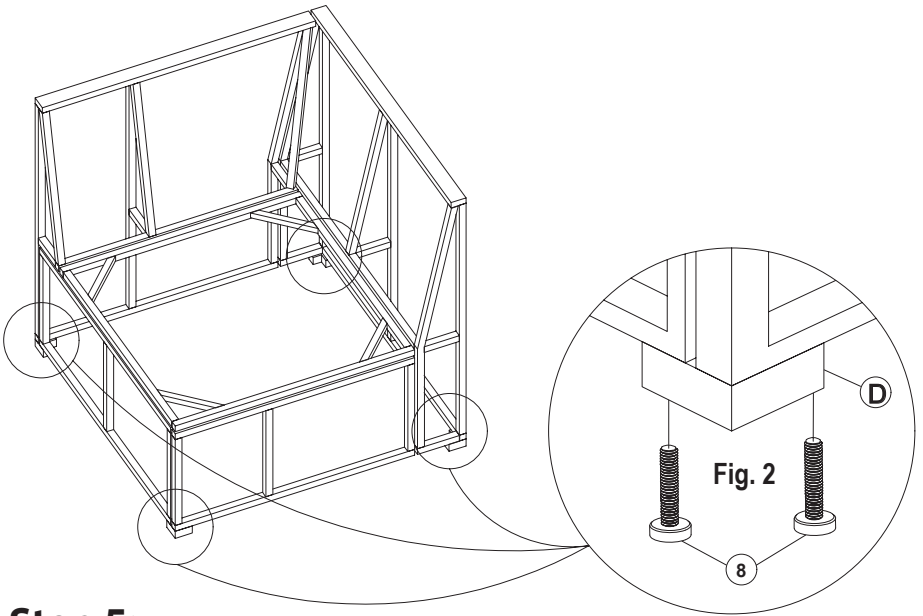

Step 5:

Turn the chair upside down. Place Corner Feet (4) at either corner of chair bottom. Insert two M6x25 Bolts (8) through each Corner Foot (4) and into bolt-threading found at the bottoms of all previously assembled parts; see Figure 2. Tighten bolts left loose throughout assembly process using Hex Key (7). Turn the chair right-side up when finished.

**Corner
Chair
Complete**

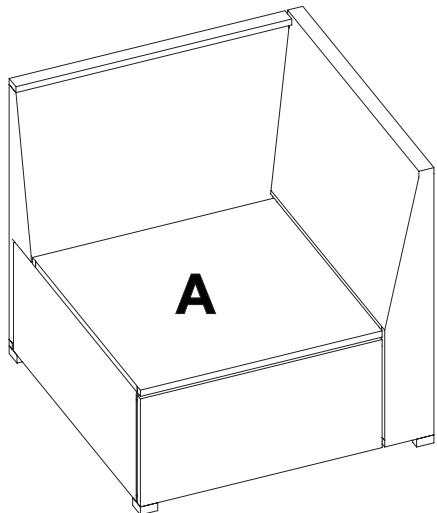

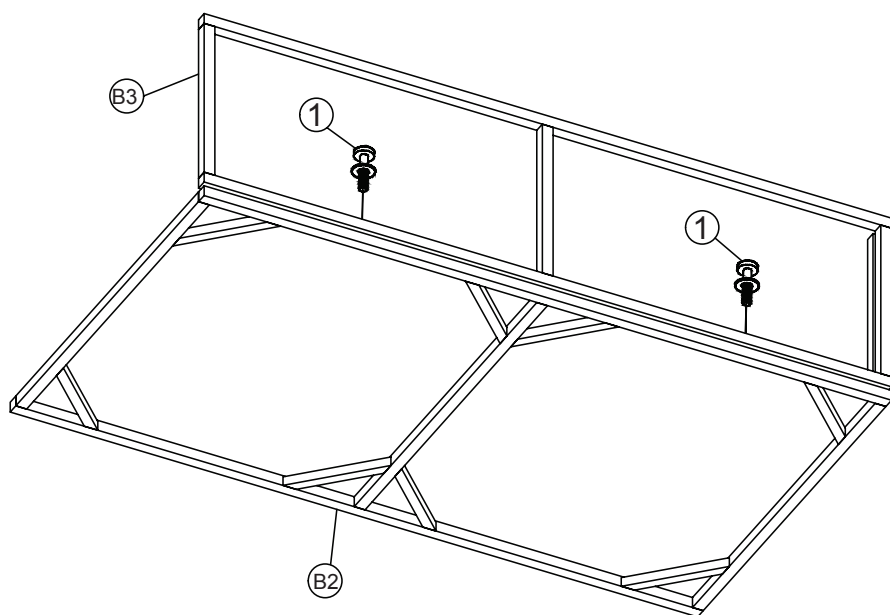

Step 1:

Set Sofa Seat (B2) upside-down on a soft, non-abrasive surface. Place Sofa Front Panel (B3) at the end of Sofa Seat (B2) as illustrated here. Insert two M6x35 Bolts (1) with Washers (3) through the top of Sofa Front Panel (B3) and into the bolt-threading found on the metal frame of Sofa Seat (B2). **Do not tighten bolts all the way until all parts have been assembled.**

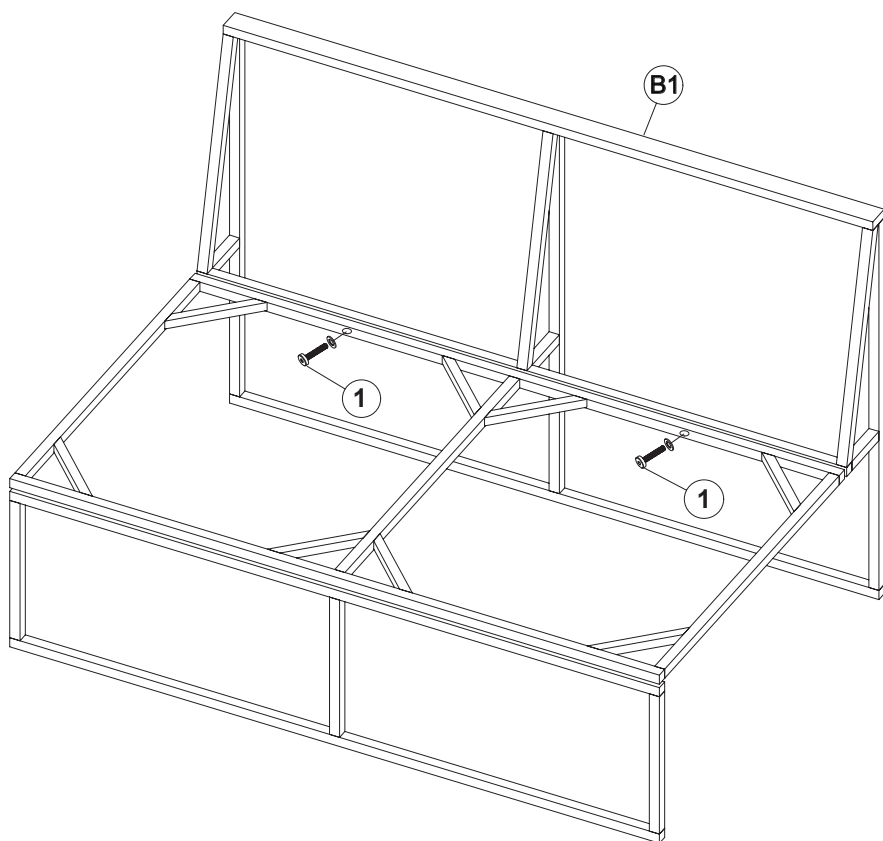

Step 2:

Turn previously assembled parts right-side up. Place Sofa Back (B1) against Sofa Seat (B2) as illustrated above. Insert two M6x35 Bolts (1) with Washers (3) through eyelets found underneath Sofa Seat (B2) and into bolt-threading found at the bottom of the sofa back of B1.

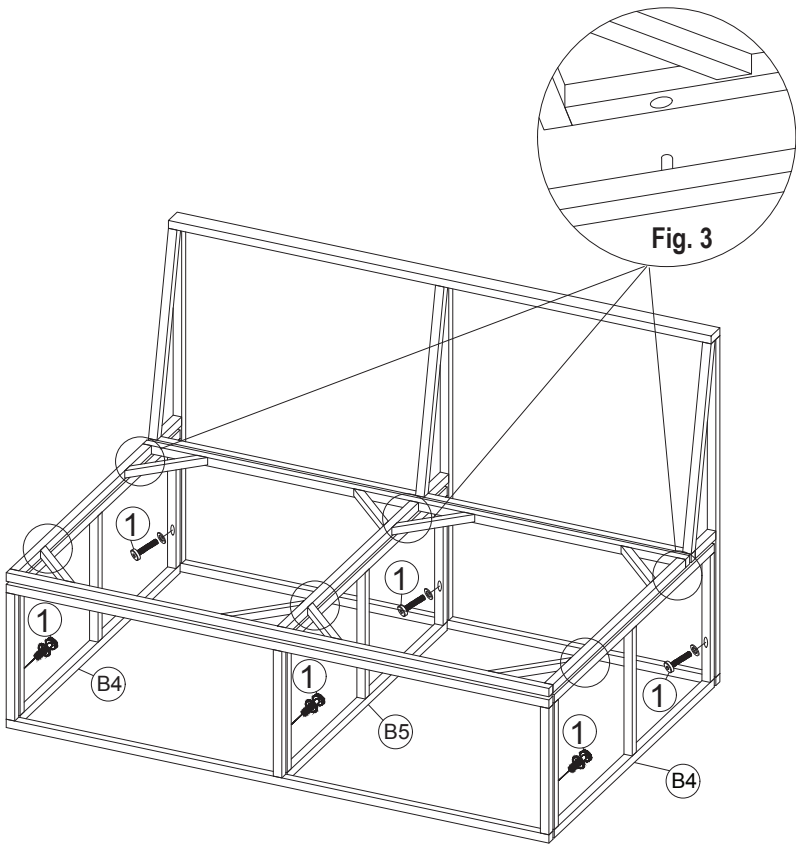

Step 3:

Place Sofa Panels (B4) on either side of sofa so that they are underneath Sofa Seat (B2). Insert pegs found at the tops of the panels into the eyelets found underneath Sofa Seat (B2); see Fig. 3. Insert one M6x35 Bolt (1) with Washer (3) through the side of Sofa Panels (B4) and into bolt-threading of Sofa Front Panel (B3). Insert one M6x35 Bolt (1) with Washer (3) through the side Sofa Panels (B4) and into the bolt-threading at the bottom Sofa Back (B1).

Place Support (B5) underneath sofa so that pegs at the top of this part fit into intended eyelets underneath Sofa Seat (B2). Insert one M6x35 Bolt (1) with Washer (3) through the side of Support (B5) and into bolt-threading found at the center of Sofa Front Panel (B3). Insert one M6x35 Bolt (1) with Washer (3) through the side of Support (B5) and into bolt-threading found at the center of Sofa Back (B1).

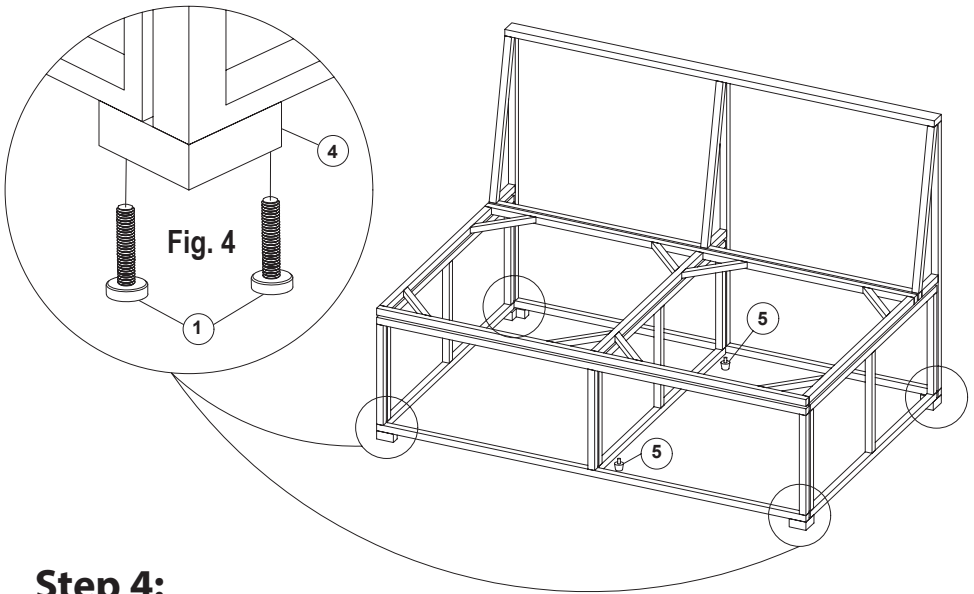

Step 4:

Turn the sofa upside down. Place Corner Feet (4) at either corner of sofa bottom. Insert two M6x25 Bolts (8) through each Corner Foot (4) and into bolt-threading found at the bottoms of all previously assembled parts; see Figure 4. Tighten bolts left loose throughout assembly process using Hex Key (7). Screw in two Feet (5) into bolt-threading on the bottom Support Panel (B5). Turn the sofa right-side up when finished.

Sofa Complete

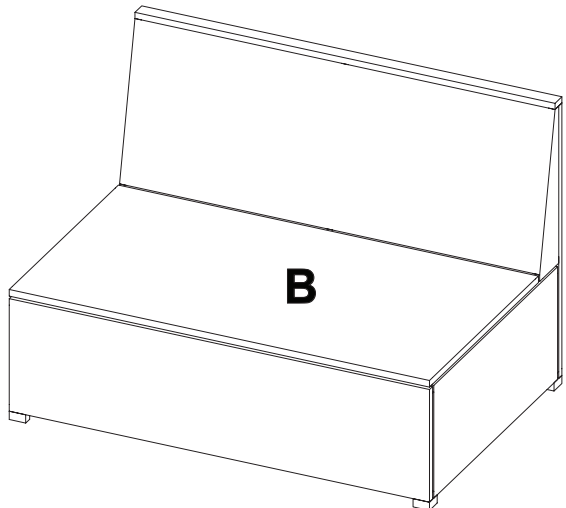

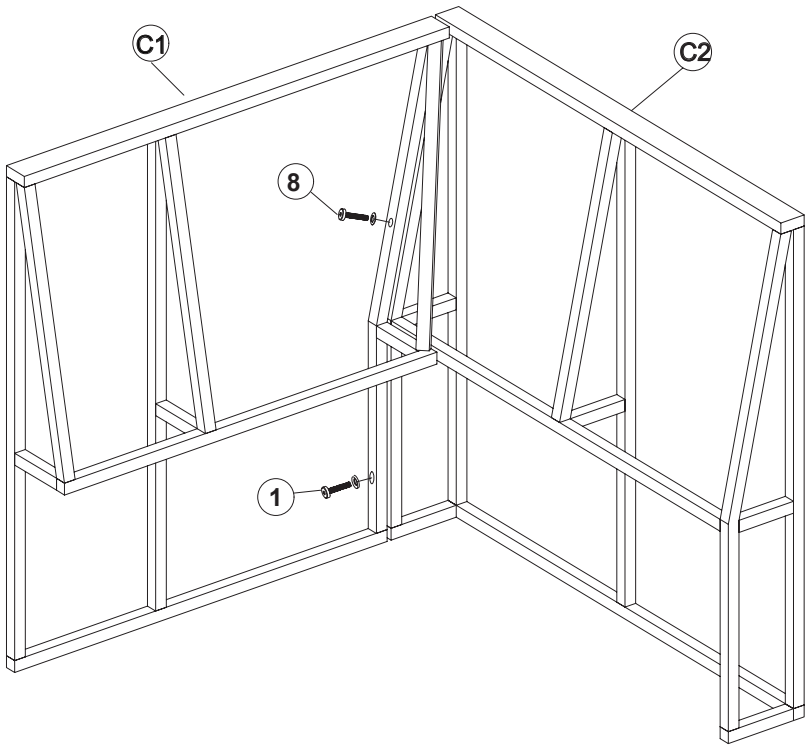

Step 1:

Bring Right Chaise Back (C1) and Left Chaise Back (C2) together as illustrated here. Insert one M6x35 Bolt (1) with Washer (3) through the bottom of Right Chaise Back (C1) and into bolt-threading found on Left Chaise Back (C2). **Do not tighten bolts all the way until all parts have been assembled.** Insert one M6x35 Bolt (8) with Washer (3) through the top of Right Chaise Back (C1) and into bolt-threading found on Left Chaise Back (C2).

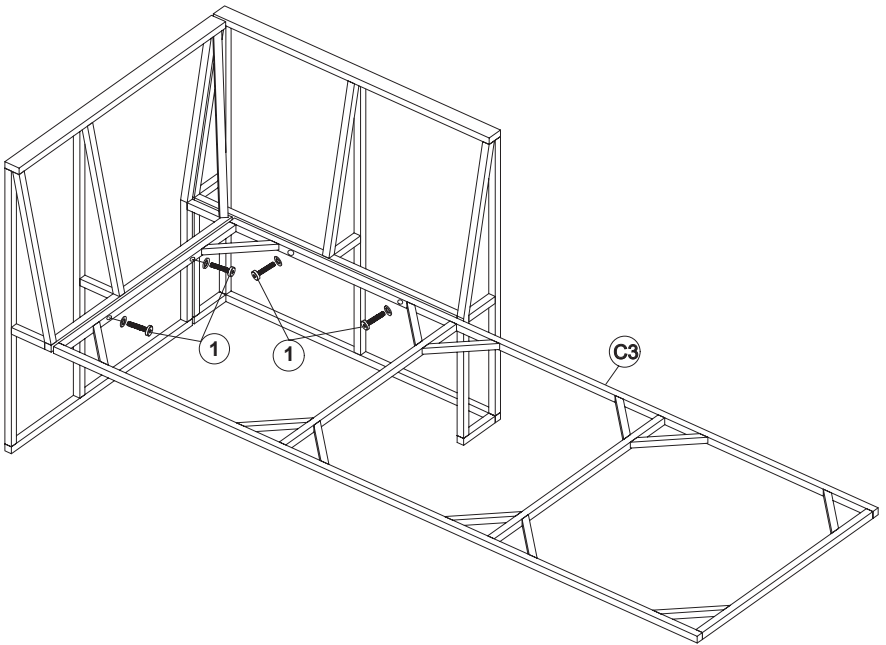

Step 2:

Insert two M6x35 Bolts (1) with Washers (3) through the bottom of Chaise Seat (C3) and into bolt-threading found at the bottom of the chaise back of C1. Insert two M6x35 Bolts (1) with Washers (3) through the bottom of Chaise Seat (C3) and into bolt-threading found at the bottom of the chaise back of C2.

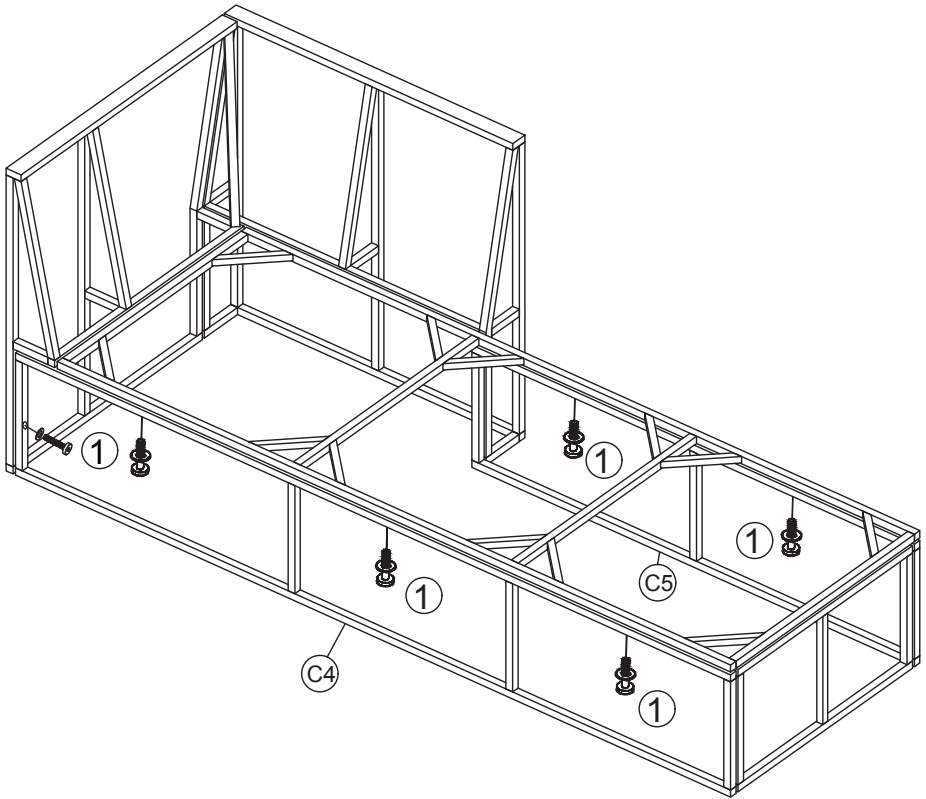

Step 3:

Place Chaise Short Panel (C5) underneath the side of Chaise Seat (C3) and against Left Chaise Back (C2) as illustrated above. Insert two M6x35 Bolts (1) with Washers (3) through the top of Chaise Short Panel (C5) and into the bolt-threading found underneath Chaise Seat (C3).

Place Chaise Long Panel (C4) underneath the side of Chaise Seat (C3) and against Right Chaise Back (C1). Insert three M6x35 Bolts (1) with Washers (3) through the top of Chaise Long Panel (C4) and into the bolt-threading found underneath Chaise Seat (C3). Insert one M6x35 Bolt (1) with Washer (3) through the side of Chaise Long Panel (C4) and into the bolt-threading found at the bottom of Right Chair Back (C1).

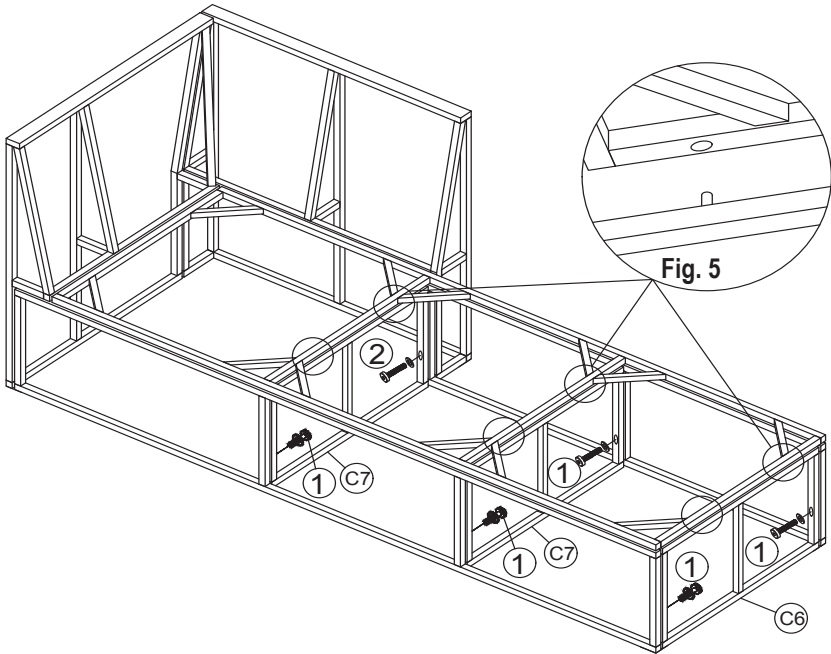

Step 4:

Place two Supports (C7) underneath chaise so that pegs at the top of these parts fit into intended eyelets underneath Chaise Seat (C3); see Figure 5. Insert one M6x35 Bolt (1) with Washer (3) through the sides of each Support (C7) and into bolt-threading found on the two center bars of Chaise Long Panel (C4).

Insert M6x55 Bolt (2) with Washer (3) through the side of Support (C7), through Chaise Short Panel (C5), and into bolt-threading found at the bottom of Left Chaise Back (C2). Insert one M6x35 Bolt (1) with Washer (3) through the side of the second Support (C7) and into bolt-threading found on the center bar of Chaise Short Panel (C5).

Place Chaise Panel (C6) underneath chaise so that pegs at the top of this part fit into intended eyelets at the end of Chaise Seat (C3); see Figure 5. Insert one M6x35 Bolt (1) with Washer (3) through the both sides of Chaise Panel (C6) and into bolt-threading found at the ends of Chaise Long Panel (C4) and Chaise Short Panel (C5).

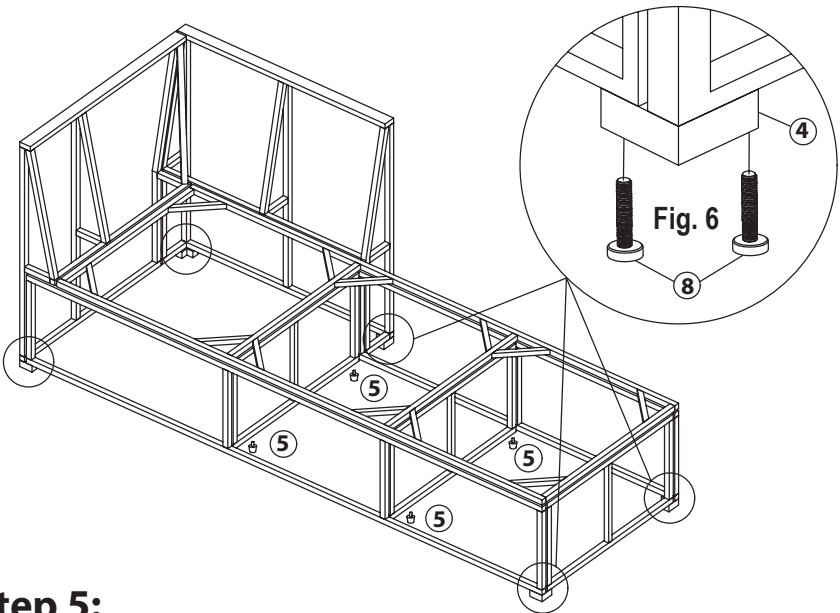

Step 5:

Turn the chaise upside down. Place Corner Feet (4) at all corners illustrated above. Insert two M6x25 Bolts (8) through each Corner Foot (4) and into bolt-threading found at the bottoms of all previously assembled parts; see Figure 6. Tighten bolts left loose throughout assembly process using Hex Key (7). Screw in two Feet (5) into bolt-threading on the bottoms of both Supports (C7). Turn the chaise right-side up when finished.

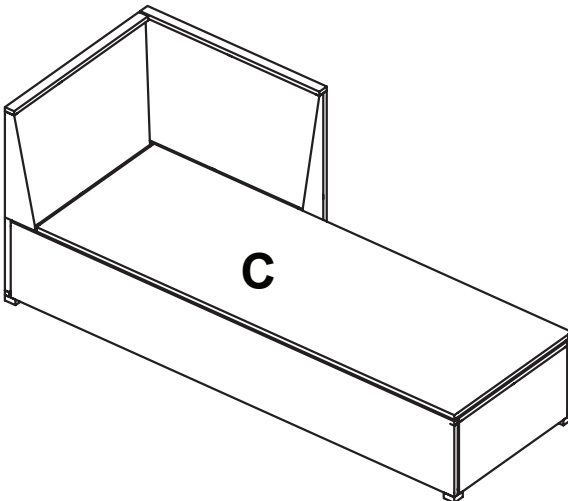

Chaise Complete

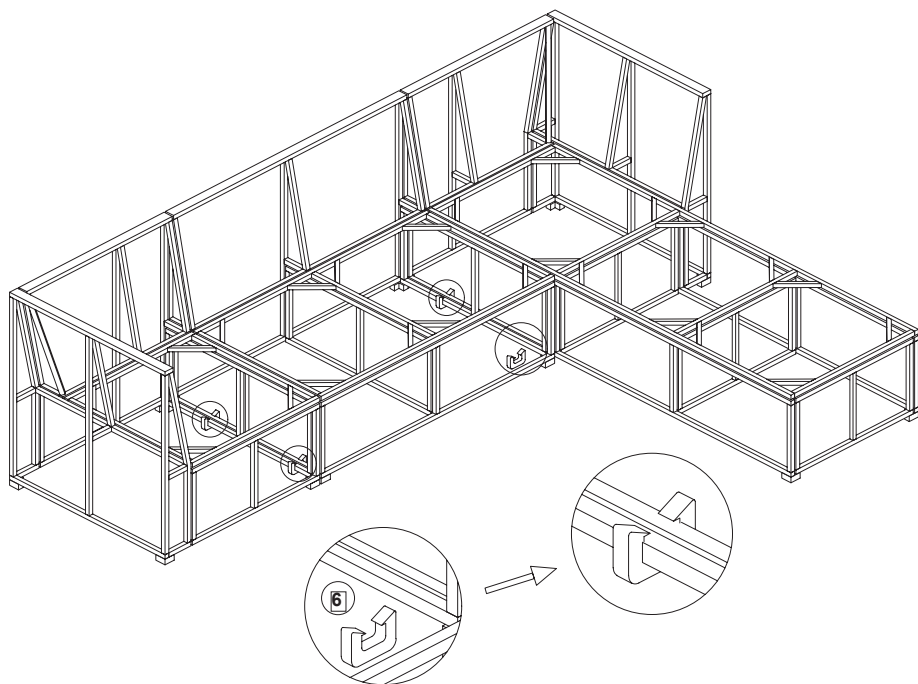

Finish

Use two Clamps (6) to lock the chair to the sofa by placing them over the frames of both seats. Use remaining two Clamps (6) to lock the opposite side of the sofa to the chaise.

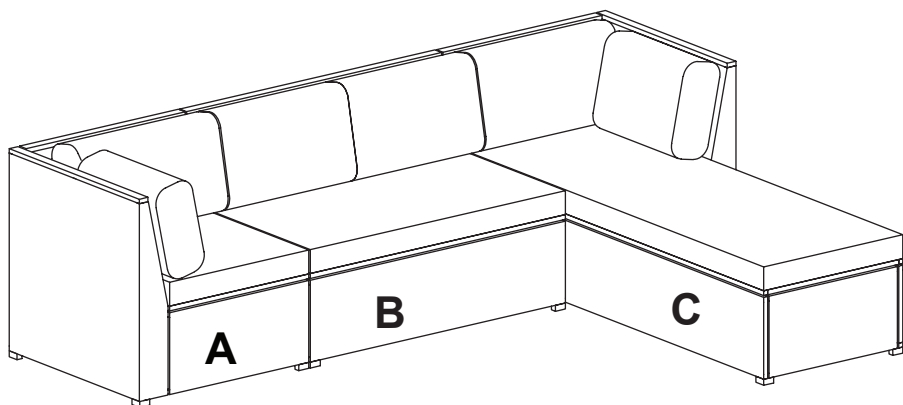

3 Piece Wicker Set with Chaise

Steel Frame with Powder Coating

Dist. by TDC USA, Inc. Fairfield, NJ 07004
©2021 All Rights Reserved. Made in Vietnam.
Item #21955

Questions and Comments
1-800-599-8898 (9 am - 5 pm EST)
www.tdcusainc.com