

3 Piece Wicker Bar Set

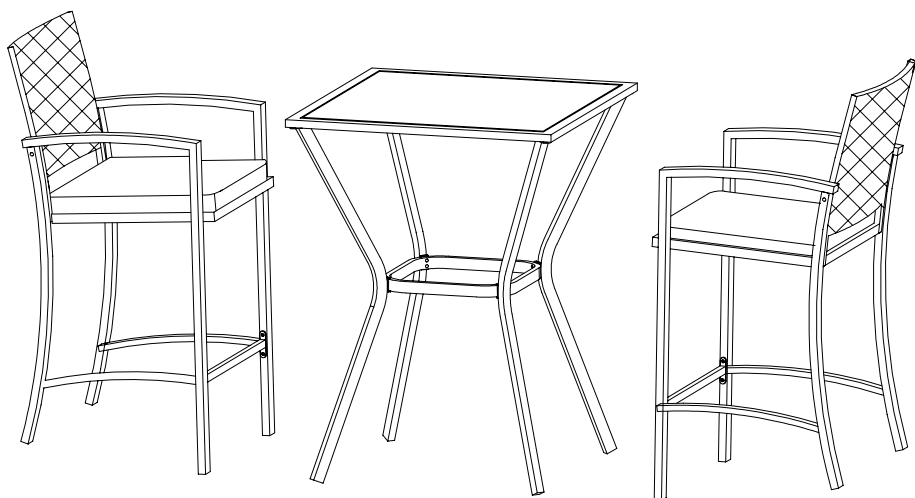

Assembly Instructions

Made in China

The owner's manual contains important safety information as well as assembly, use and maintenance instructions. Keep the packaging and bags away from children and dispose of all packaging properly before use. Keep this manual for future reference.



**PLEASE DO NOT
RETURN THIS
PRODUCT
TO THE STORE**

We will be happy to correct any problems that you may have, or answer any of your questions regarding the purchase of this product. Please contact us at our Toll Free customer service number 1-800-599-8898 for any assistance and replacement parts. Thank You.

Dist. by TDC USA, Inc. Fairfield, NJ 07004
©2021 All Rights Reserved.
Made in China
Item 22502
www.tdcusainc.com

⚠ WARNING!

- Keep all children and pets away from assembly area. Children and pets should be supervised when they are in the area of the product construction.
- Some parts may contain sharp edges. When assembling and using this product, basic safety precautions should always be.
- Please read all the instructions and warnings before assembling. In order to make the whole product adjust to the best, please install all the screws on the product and tighten all the screws after adjusting the product which can stand on the floor even. Not intended for commercial use.
- Check all bolts for tightness before use.
- **IMPORTANT** - check and tighten bolts often to keep them secure

• **CHOKING HAZARD** - Small parts. Not suitable for children under 36 months. The product contains small parts, keep children away when assembling.

• **ADULT ASSEMBLY REQUIRED.**
Always remove protective material and poly bags and dispose before assembly.

A (x2) Armrest	B (x2) Armrest	C (x2) Chair Seat	D (x2) Chair Back
E (x2) Chair Support	F (x4) Table Leg	G (x1) Table Support	H (x1) Glass
I (x1) Table	J (x12) M6x15 Bolt	K (x16) M6x30 Bolt	L (x4) M6x40 Bolt
M (x4) M6x55 Bolt	N (x36) Washer	O (x2) Cushion	AA (x1) Hex Key

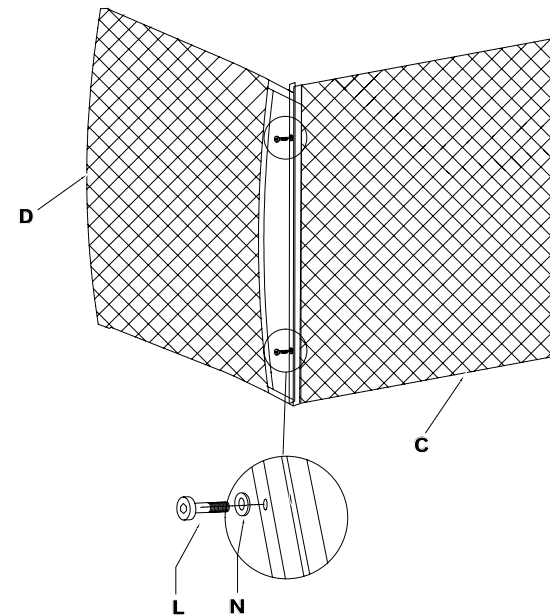

Step 1:

Place Chair Seat (C) and Chair Back (D) on the ground as illustrated here. Insert two Bolts M6x40 (L) with Washers (N) through the eyelets found underneath of Chair Seat (C) and into the bolt-threading found on the horizontal bar at the bottom of Chair Back (D). **Do not tighten bolts all the way until all parts have been assembled.**

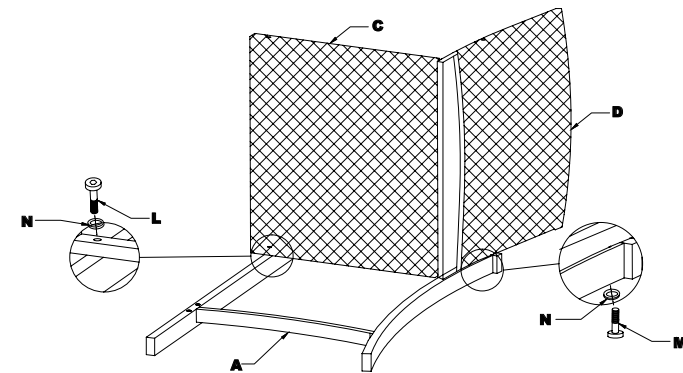

Step 2:

Place Armrest (A) on the ground and place the previously assembled parts over this part as illustrated here.

Insert one Bolt M6x55 (M) with Washer (N) through the eyelet found at the back of Armrest (A) and into the bolt-threading found on the right-side of Chair Back (D).

Insert one Bolt M6x40 (L) with Washer (N) through the eyelet found underneath the front-right of Chair Seat (C) and into the bolt-threading found on the side of the front leg of Armrest (A).

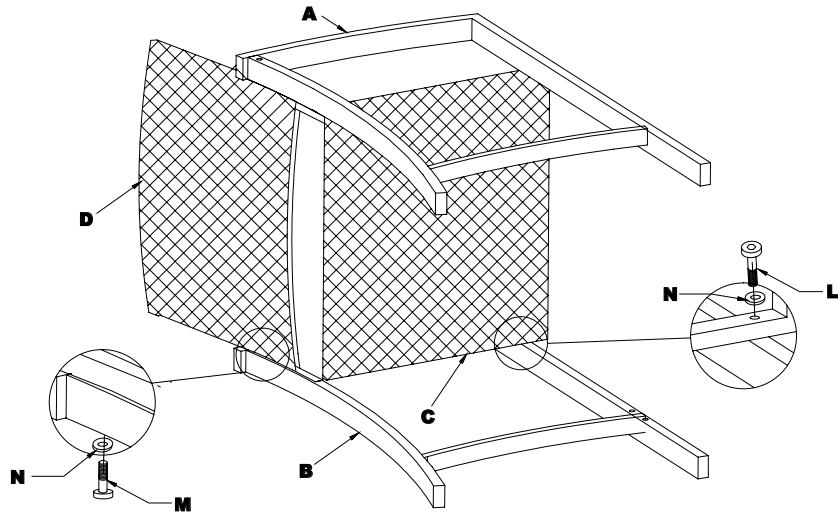

Step 3:

Place Armrest (B) on the ground and place previously assembled parts on top of this part as illustrated here. Insert one Bolt M6x55 (M) with Washer (N) through the eyelet found at the back of Armrest (B) and into the bolt-threading found on the left-side of Chair Back (D).

Insert one Bolt M6x40 (L) with Washer (N) through the hole found underneath the front-left of Chair Seat (C) and into the bolt-threading found on the side of the front leg of Armrest (B).

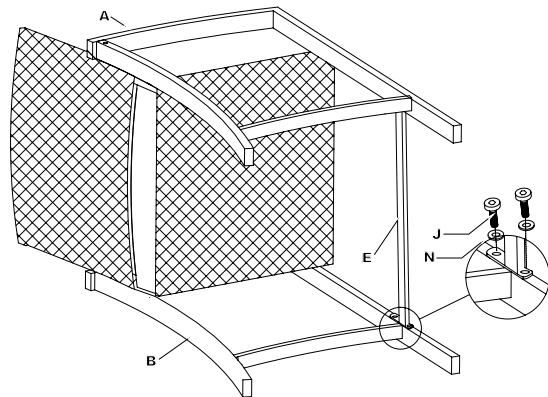

Step 4:

Place Chair Support (E) in between the front legs of Armrest (A & B).

Insert two Bolts M6x15 (J) with Washers (N) through eyelets at either end Chair Support (E) and into the bolt-threading found on the inside of legs of Armrest (A & B). Tighten all bolts left loose throughout assembly process using Hex Key (AA). Follow these steps to assemble the second chair for this set.

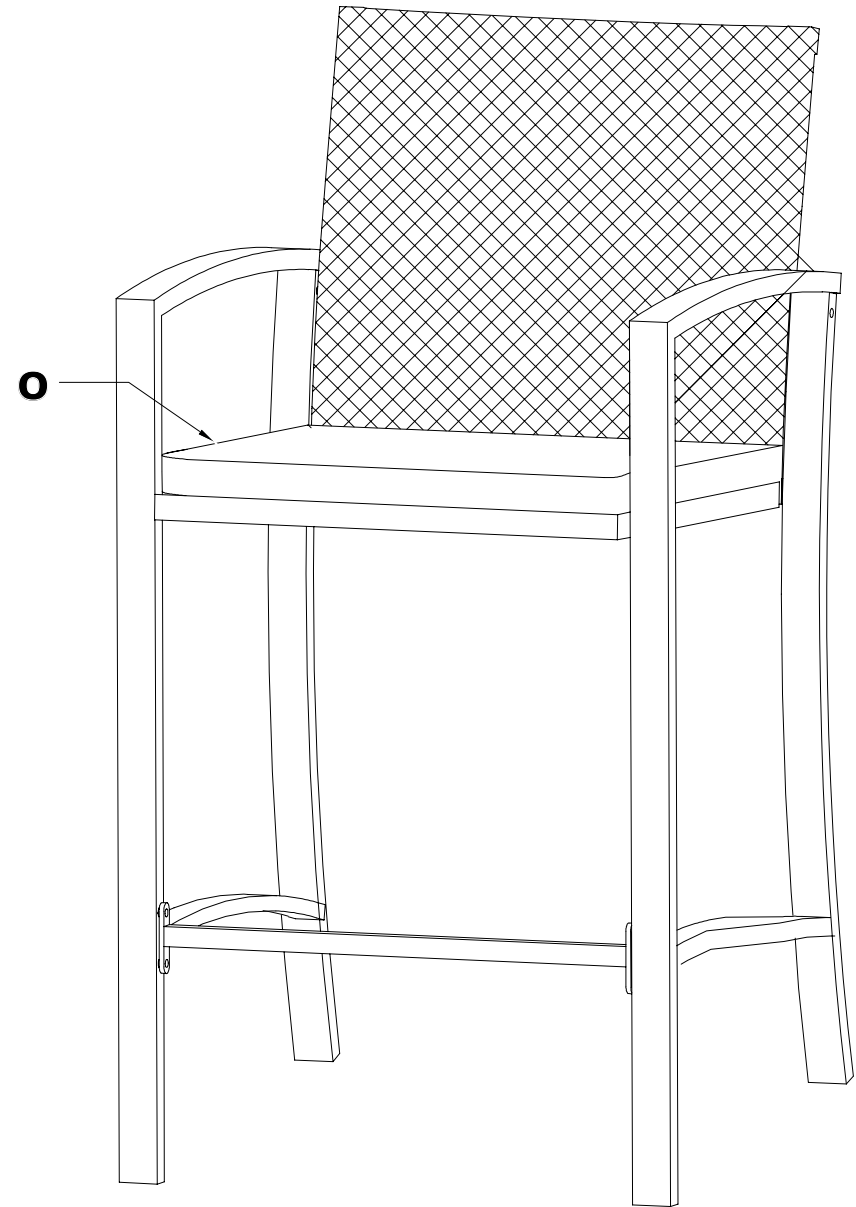

Step 5:

Place Cushions (O) on top of Chair Seats (C) when assembly of both chairs is complete.

Step 1:

Cut the straps that secure the glass to the table and carefully remove the glass and set it aside. Place Table (I) upside-down on a soft, non-abrasive surface. Place Table Leg (F) at the corner of Table (I) where there are bolt-threading intended for bolts to be inserted into.

Insert Bolt M6x15 (J) with Washer (N) through the eyelet at the top of Leg (F) and into the bolt-threading on the bottom of Table (I). **Do not tighten bolts all the way until all parts have been assembled.** Follow this step to assemble the remaining Table Legs (F) to each corner of Table (I).

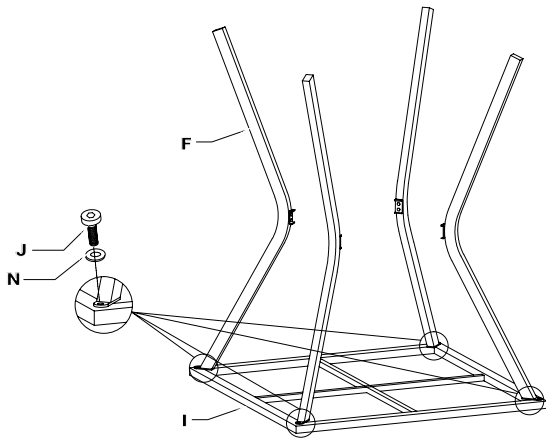
**Step 2:**

Place the Table Support (G) in between the Table Legs (F). Insert two Bolts M6x30 (K) with Washers (N) through eyelets at each corner of Table Support (G) and into the bolt-threading found at the center-inside of each Table Leg (F). Tighten all bolts left loose throughout assembly process using Hex Key (AA).

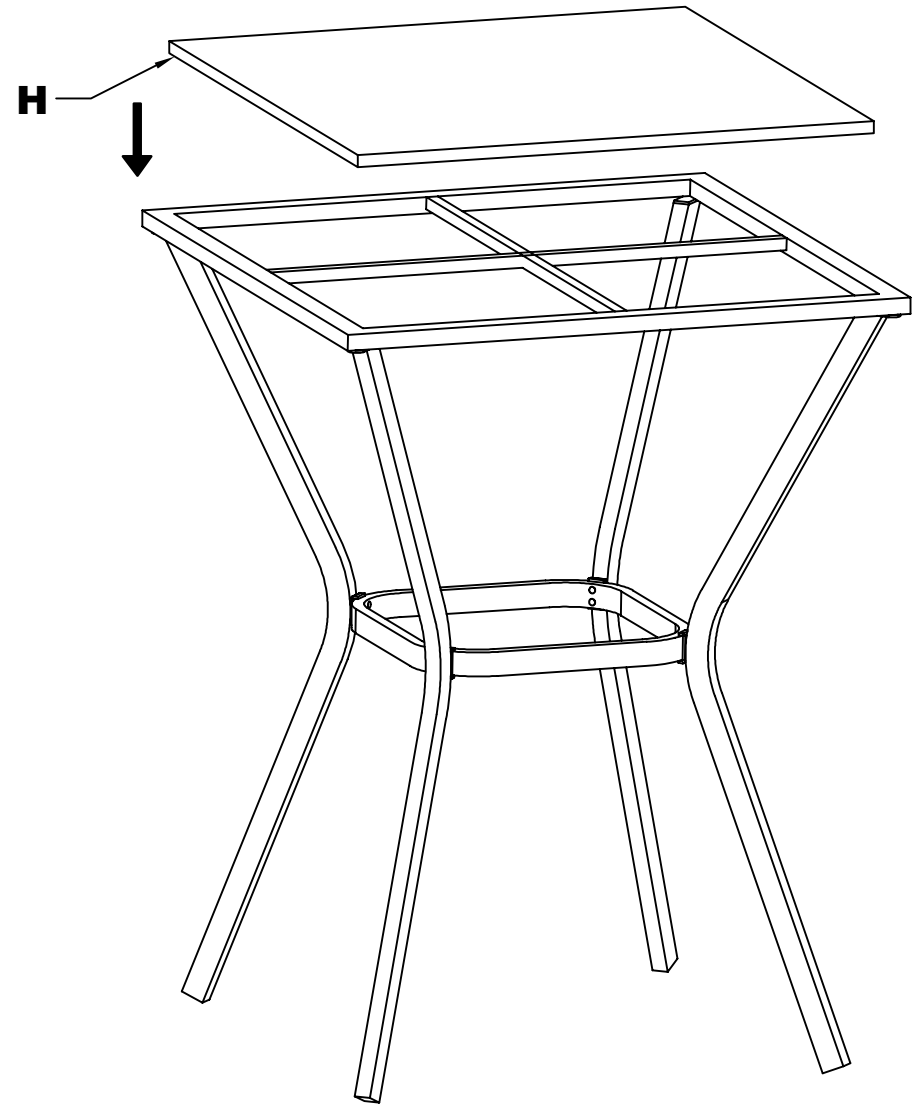
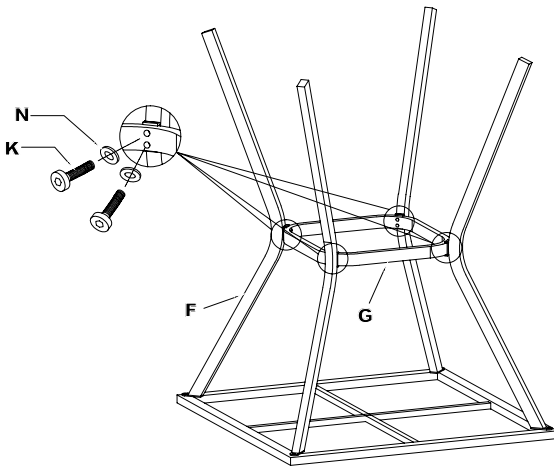
**Step 3:**

Turn the table right-side up. Carefully place Glass (H) on top of Table (I). The table is ready to be used.

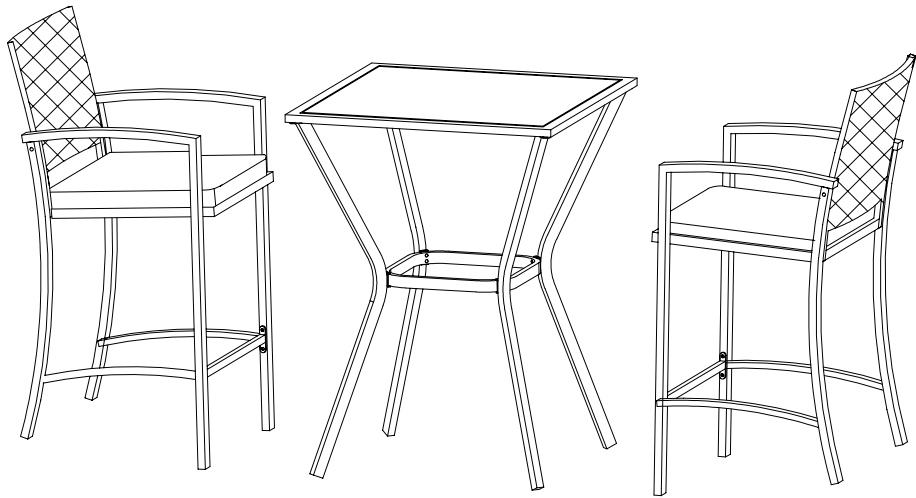

3 Piece Wicker Bar Set

Dist. by TDC USA, Inc. Fairfield, NJ 07004
©2021 All Rights Reserved. Made in China.
Item #22502

Questions and Comments
1-800-599-8898 (9 am - 5 pm EST)
www.tdcusainc.com