

3 Piece Rocking Chair Set



Assembly Instructions

Made in China

The owner's manual contains important safety information as well as assembly, use and maintenance instructions. Keep the packaging and bags away from children and dispose of all packaging properly before use. Keep this manual for future reference.



**PLEASE DO NOT
RETURN THIS
PRODUCT
TO THE STORE**

We will be happy to correct any problems that you may have, or answer any of your questions regarding the purchase of this product. Please contact us at our Toll Free customer service number 1-800-599-8898 for any assistance and replacement parts. Thank You.







Dist. by TDC USA, Inc. Fairfield, NJ 07004
©2021 All Rights Reserved.
Made in China
Item 22104
www.tdcusainc.com

⚠ WARNING!

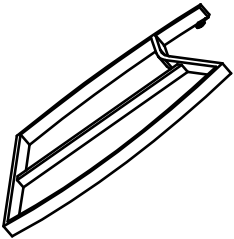
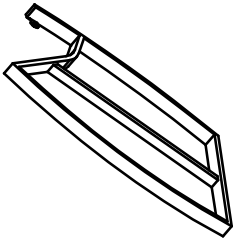
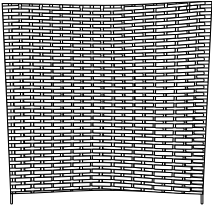
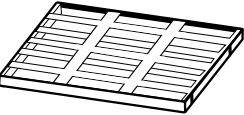
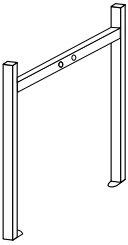
- **Keep all children and pets away from assembly area. Children and pets should be supervised when they are in the area of the product construction.**
- **Some parts may contain sharp edges. When assembling and using this product, basic safety precautions should always be.**
- **Please read all the instructions and warnings before assembling. In order to make the whole product adjust to the best, please install all the screws on the product and tighten all the screws after adjusting the product which can stand on the floor even. Not intended for commercial use.**
- **Check all bolts for tightness before use.**
- **IMPORTANT - check and tighten bolts often to keep them secure**

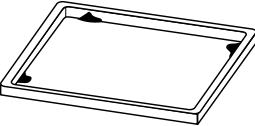
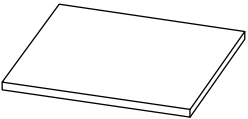
• **CHOKING HAZARD** - Small parts. Not suitable for children under 36 months. The product contains small parts, keep children away when assembling.

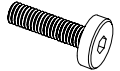
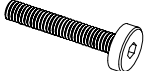
• **ADULT ASSEMBLY REQUIRED.**
Always remove protective material and poly bags and dispose before assembly.

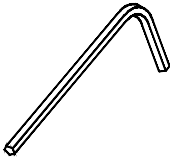
 A (x2) Armrest	 B (x2) Armrest	 C (x2) Chair Back	
 D (x2) Chair Seat	 E (x2) Table Leg	 F (x1) Support	
 G (x1) Table	 H (x1) Glass	 I (x2) Seat Cushion	
 K (x16) M6x15 Bolt	 L (x8) M6x25 Bolt	 M (x24) Washer	 AA (x1) Hex Key

Step 1:

Set the Armrest (A) on a soft, non-abrasive surface.

Insert one Bolt M6x15 (K) with Washer (M) through the eyelet found at the bottom-left corner of Chair Back (C) and into the bolt-threading found at the center-back of Armrest (A). **Do not tighten bolts down until assembly of the chair is complete.**

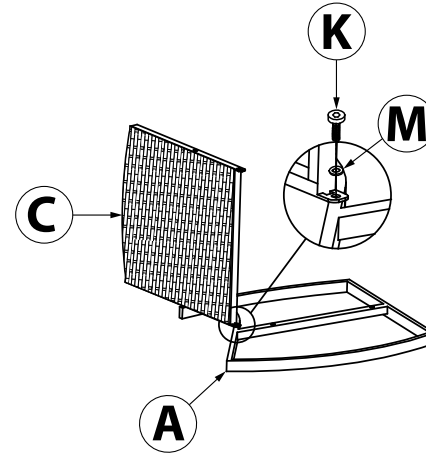

Step 2:

Turn the previously assembled parts over as illustrated here. Insert one Bolt M6x15 (K) with Washer (M) through the eyelet found underneath armrest of part A and into bolt-threading on the side of Chair Back (C).

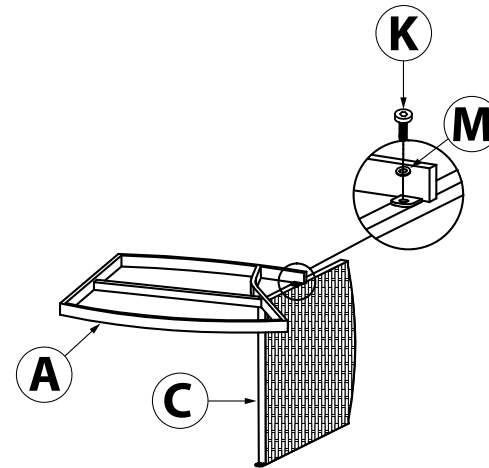

Step 3:

Set the Armrest (B) on a soft, non-abrasive surface and place previously assembled parts on top of it as illustrated here. Insert one Bolt M6x15 (K) with Washer (M) through the eyelet found at the bottom-right corner of Chair Back (C) and into the bolt-threading found at the center-back of Armrest (B).

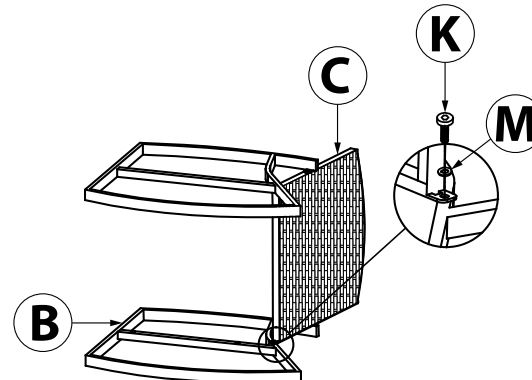

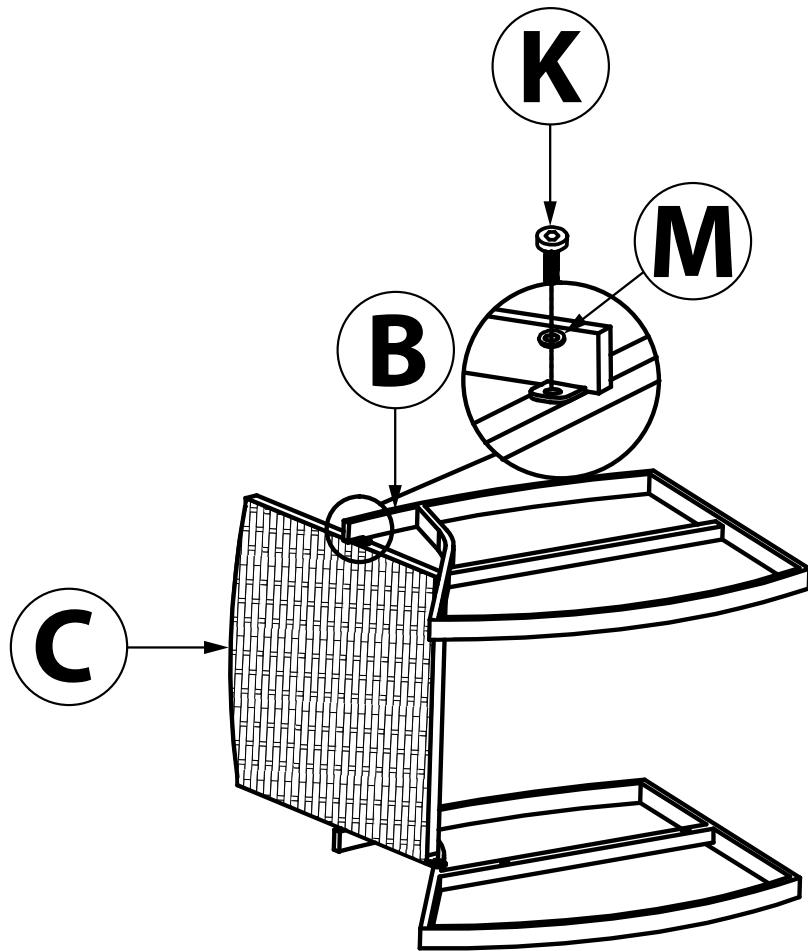
**Step 4:**

Turn the previously assembled parts over as illustrated here. Insert one Bolt M6x15 (K) with Washer (M) through the eyelet found underneath armrest of part B and into bolt-threading on the opposite side of Chair Back (C).

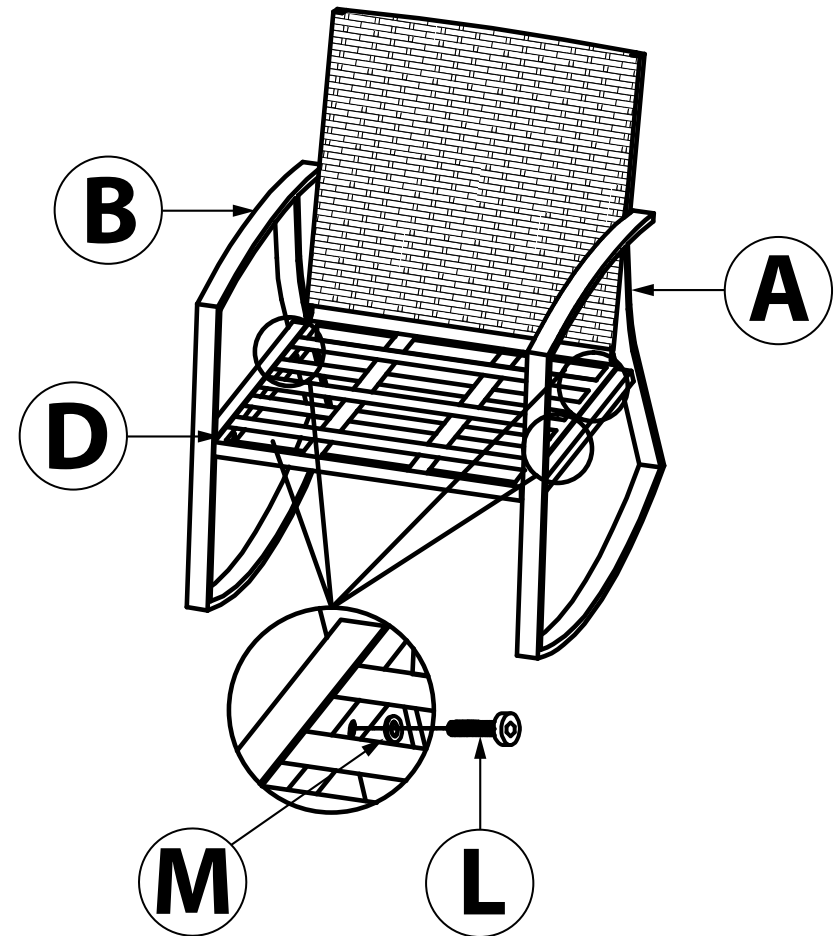
**Step 5:**

Place Chair Seat (D) in between Armrests (A&B).

Insert two Bolts M6x25 (L) with Washers (M) through the eyelets found underneath the left-side of Chair Seat (D) and into the bolt-threading found on the horizontal bar of Armrest (A). Follow this step to connect Chair Seat (D) to the horizontal bar of Armrest (B). Tighten all bolts left loose throughout assembly process using Hex Key (AA). Follow these steps to assemble the second chair for this set.

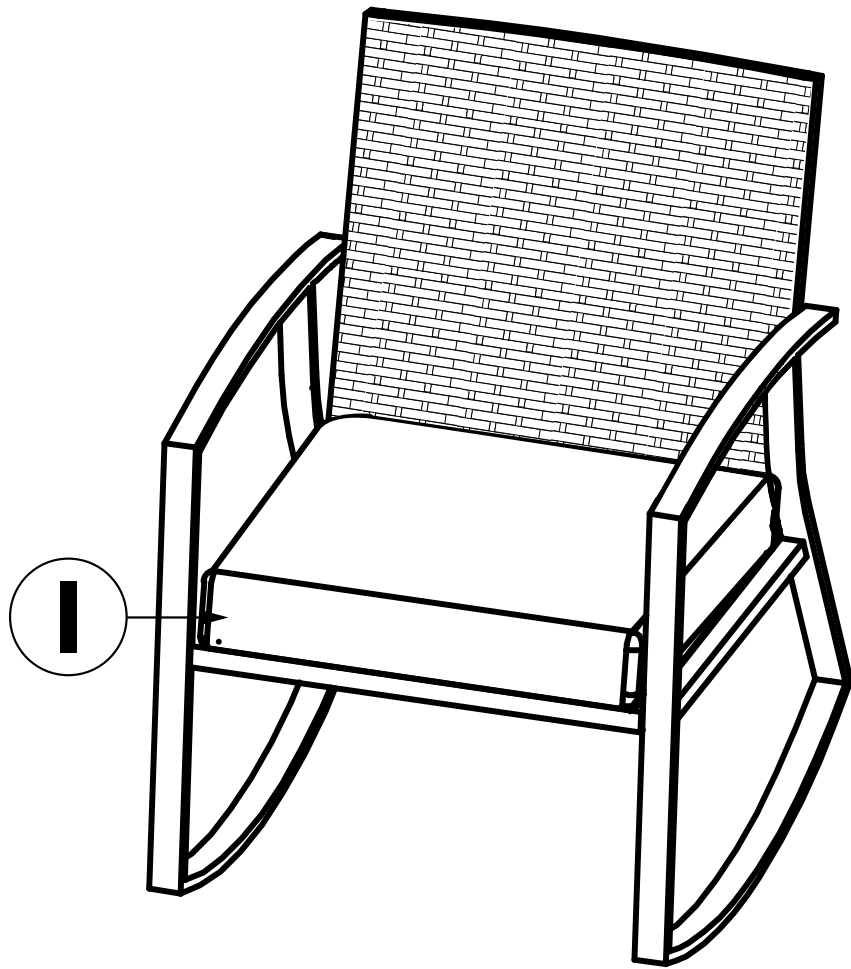

Step 6:

Place Seat Cushions (I) on top of Chair Seats (D) when assembly of both chairs is complete. The chairs are ready to be used.

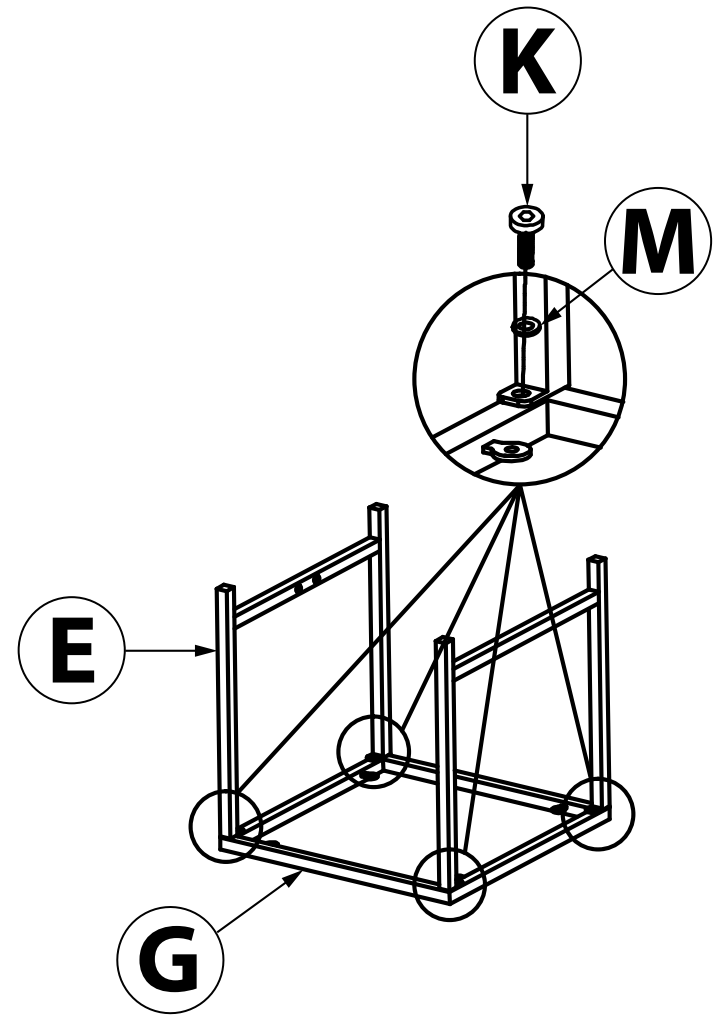

Step 1:

Remove Glass (H) from Table (G) carefully and set it aside until assembly is complete. Set the Table (G) upside-down on a soft, non-abrasive surface.

Insert one Bolt M6x15 (K) with Washer (M) through the eyelets at the ends of Leg (E) and into the bolt-threading found at the corners [underneath] of Table (G). **Do not tighten bolts down until assembly of the table is complete.** Follow this step to assemble the second Table Leg (E) on the opposite side of Table (G).

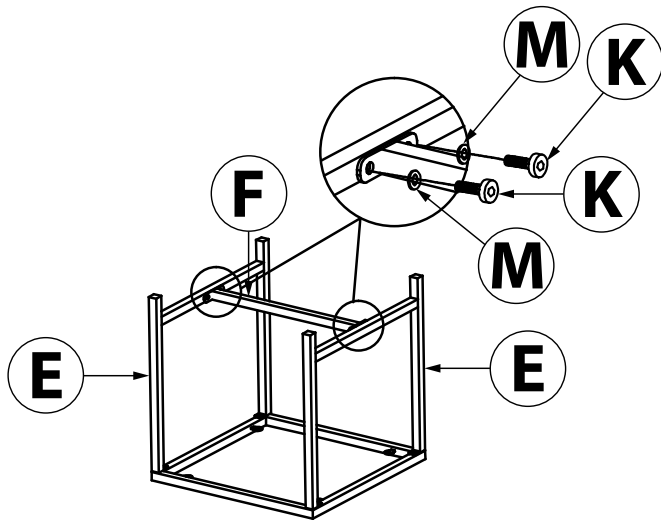

Step 2:

Insert two Bolts M6x15 (K) with Washers (M) through eyelets at either end Table Support (C) and into the bolt-threading found on the horizontal bar of each Table Leg (E). Tighten all bolts left loose throughout assembly process using Hex Key (AA).

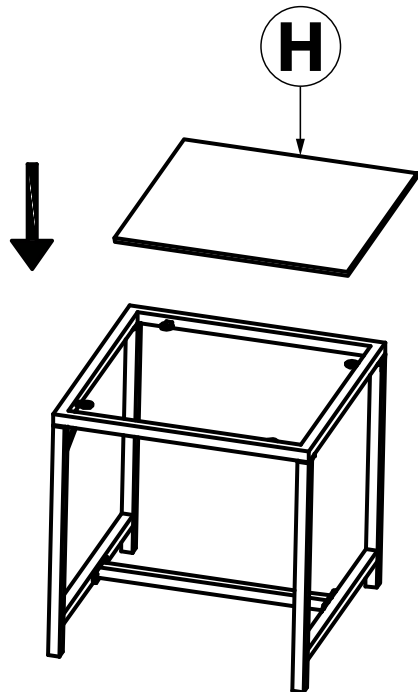

Step 3:

Turn the table right-side up. Carefully place Glass (H) into the center of Table (G) rim. The table is ready to be used.

3 Piece Rocking Chair Set

Dist. by TDC USA, Inc. Fairfield, NJ 07004
©2021 All Rights Reserved. Made in China.
Item #22104

Questions and Comments
1-800-599-8898 (9 am - 5 pm EST)
www.tdcusainc.com