

Two Person Swing

Steel Frame with Powder Coating



Assembly Instructions

Made in China

The owner's manual contains important safety information as well as assembly, use and maintenance instructions. Keep the packaging and bags away from children and dispose of all packaging properly before use. Keep this manual for future reference.



**PLEASE DO NOT
RETURN THIS
PRODUCT
TO THE STORE**

We will be happy to correct any problems that you may have, or answer any of your questions regarding the purchase of this product. Please contact us at our Toll Free customer service number 1-800-599-8898 for any assistance and replacement parts. Thank You.

Dist. by TDC USA, Inc. Fairfield, NJ 07004

©2020 All Rights Reserved.

Made in China

Item 21636

www.tdcusainc.com











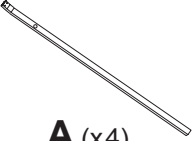
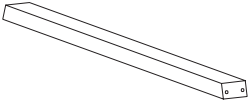



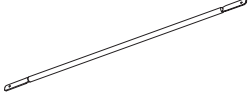

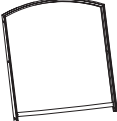

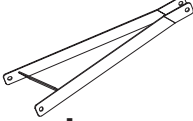
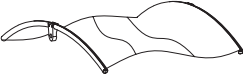
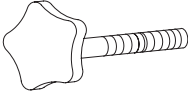
**WARNING!**

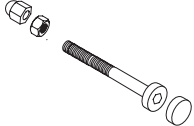
- **Keep all children and pets away from assembly area. Children and pets should be supervised when they are in the area of the product construction.**
- **Some parts may contain sharp edges. When assembling and using this product, basic safety precautions should always be.**
- **Please read all the instructions and warnings before assembling. In order to make the whole product adjust to the best, please install all the screws on the product and tighten all the screws after adjusting the product which can stand on the floor even. Not intended for commercial use.**
- **Check all bolts for tightness before use.**
- **IMPORTANT - check and tighten bolts often to keep them secure**

• **CHOKING HAZARD** - Small parts. Not suitable for children under 36 months. The product contains small parts, keep children away when assembling.

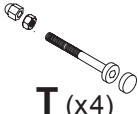
• **ADULT ASSEMBLY REQUIRED.**

Always remove protective material and poly bags and dispose before assembly.

| | | | | |
|---|---|--|---|---|
|  <p>A (x4) Leg</p> |  <p>B (x2) Leg Support</p> |  <p>C (x1) Swing Support</p> | | |
|  <p>D (x2) Arm Rest</p> |  <p>E (x2) Swing Arm</p> |  <p>F (x2) Swing Arm</p> | | |
|  <p>G1 (x1) Swing Back</p> |  <p>G2 (x1) Swing Back</p> |  <p>H (x1) Swing Seat</p> | | |
|  <p>I (x2) Connector</p> |  <p>J (x1) Canopy</p> |  <p>K (x2) Dial</p> | | |
|  <p>L (x2) Hook</p> |  <p>M (x4) Spacer</p> |  <p>N (x2) M6x55 Bolt</p> | | |
|  <p>O (x8) M6x35 Bolt</p> |  <p>P (x4) M6x35 Bolt</p> |  <p>R (x2) M6x70 Bolt</p> |  <p>S (x4) M6x38 Bolt</p> |  <p>T (x4) M6x80 Bolt</p> |
|  <p>U (x4) M6x60 Bolt</p> |  <p>V (x1) M6x40 Bolt</p> |  <p>W (x2) M6x25 Bolt</p> |  <p>X (x1) Wrench & Hex Key</p> | |

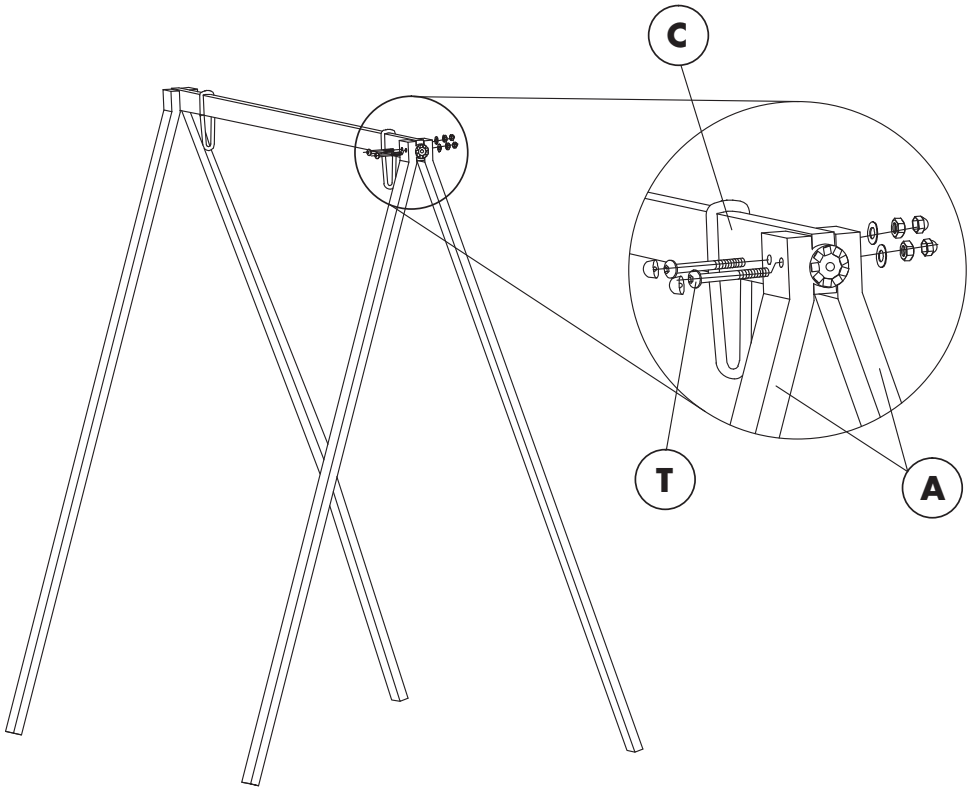

Step 1:

Insert two Bolts M6x85 (T) through the top holes of Leg (A), through two holes at the end of Swing Support (C), and through a second Leg (A). Tighten a nut halfway down on each bolt to hold parts in place with Wrench and Hex Key (X). It is advised to keep all parts loose until unit is completely assembled. Follow these steps to assemble the second set of Legs (A) to the opposite side of Swing Support (C).

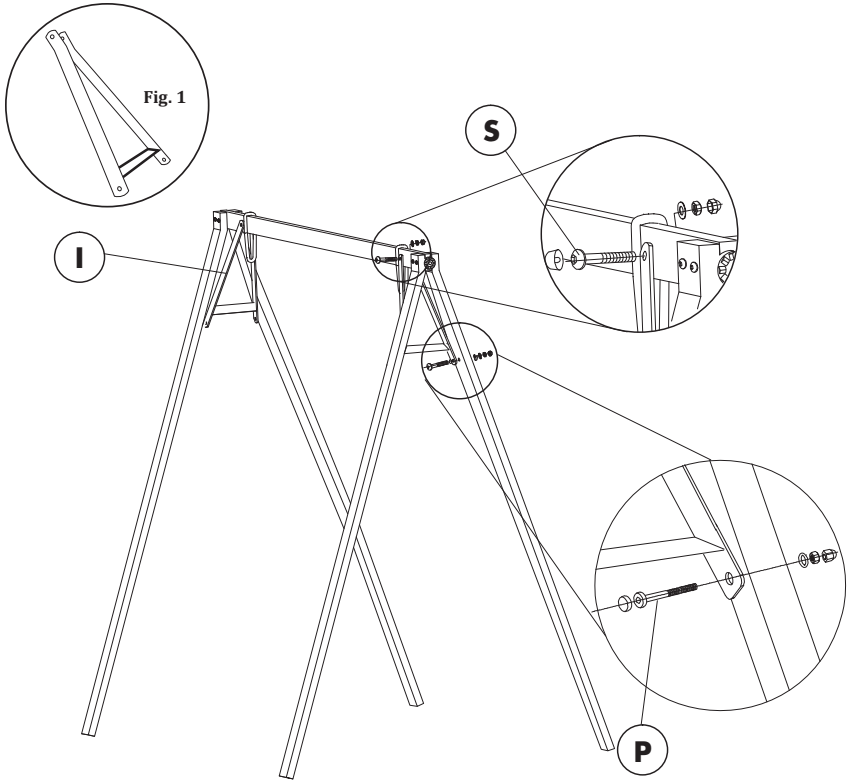

Step 2:

Place Connector (I) between assembled Legs (A); see Fig. 1 for correct orientation of Connector (I) before placing between these parts. Insert Bolt M6x38 (S) through the top hole of Connector (I), through the remaining hole in Swing Support (C) near each set of legs, and through the opposite side of Connector (I). Tighten a nut halfway down to hold parts in place with Wrench and Hex Key (X). Follow these steps to assemble the second Connector (I) to the opposite side of Swing Support (C).

Insert two Bolts M6x35 (P) through the bottom holes of Connector (I) and through Legs (A). Tighten a nut halfway down on each bolt to hold parts in place with Wrench and Hex Key (X). Follow these steps to assemble the second Connector (I) to the second set of Legs (A).

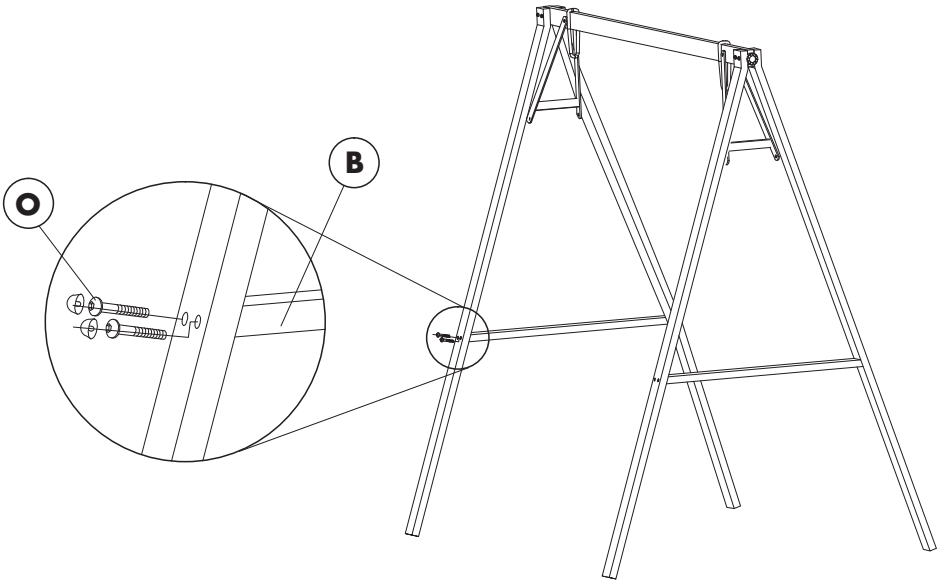

Step 3:

Place Leg Support (B) between Legs (A). Insert two Bolts M6x35 (O) through the remaining holes about halfway down legs and into Leg Support (B). Follow this step to secure the opposite side Leg Support (B) to the adjacent Leg (A). Follow these steps to secure the second Leg Support (B) to the remaining set of Legs (A). Tighten all bolts left loose throughout the assemble of the swing frame using Wrench and Hex Key (X).

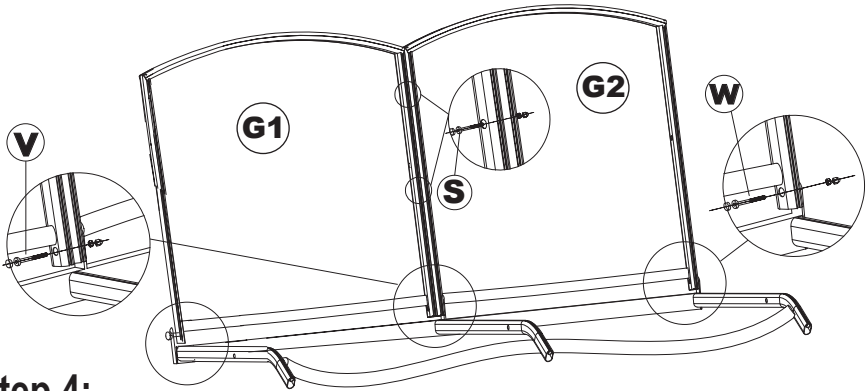

Step 4:

Place Swing Back (G1) and Swing Back (G2) together as illustrated above. Insert two Bolts M6x38 (S) through Swing Back (G1) and Swing Back (G2). Tighten nuts halfway down to hold parts in place with Wrench and Hex Key (X). Place assembled Swing Backs (G1 & G2) on the ground with the front of these part facing up. Insert Bolt M6x40 (V) through the hole at the bottom-right of Swing Back (G1), through hole at the bottom-left Swing Back (G2) and through the hole at the center-back of Swing Seat (H). Tighten a nut halfway down to hold parts in place with Wrench and Hex Key (X).

Insert one Bolt M6x25 (W) through the hole at the bottom-left of Swing Back (G1) and through the holes at the back-corner of Swing Seat (H). Tighten Bolt M6x25 (W) completely to secure these parts together. Follow this step to connect Swing Back (G2) to Swing Seat (H).

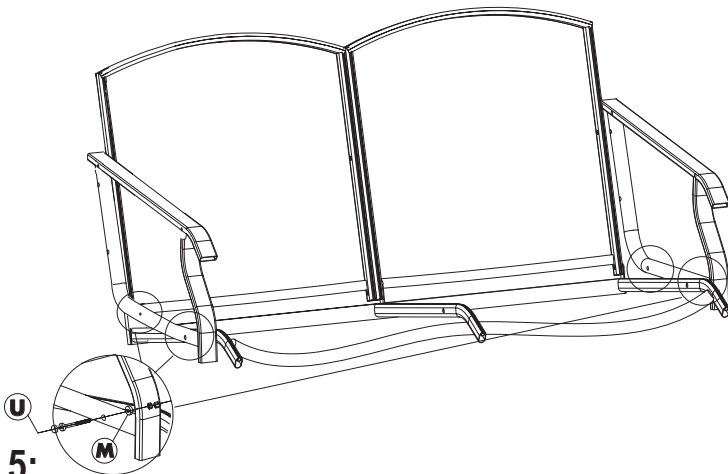

Step 5:

Place the bottom of Armrest (D) against the end of Swing Seat (H). Insert one Bolt M6x60 (U) through the bottom-front of Armrest (D), through Spacer (M), and through the hole found at the front-side of Swing Seat (H). Tighten a nut halfway down on bolt to hold parts in place with Wrench and Hex Key (X). Follow these steps to assemble the second Armrest (D) to the opposite side of Swing Seat (H).

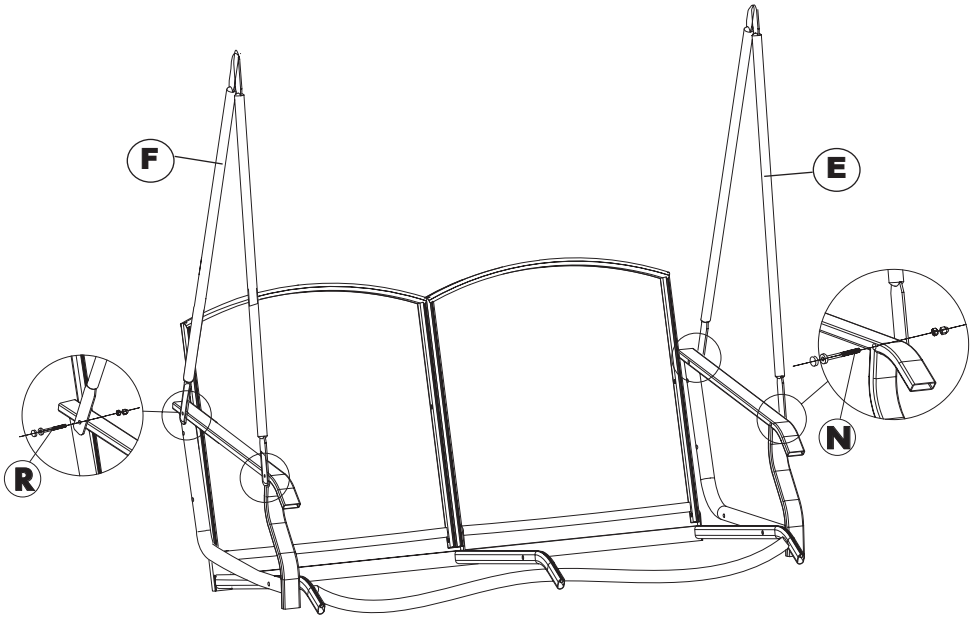

Step 6:

Insert Bolt M6x70 (R) through the end of Swing Arm (F), through the hole at the back of upper bar of Armrest (D), and through the hole found at the back-center of Swing Back (G). Tighten a nut halfway down on bolt to hold parts in place with Wrench and Hex Key (X). Follow these steps to assemble the second Swing Arm (F) to the Armrest (D) and Swing Seat (H). Insert Bolt M6x55 (N) through the front of upper bar of Armrest (D) and through the end of Swing Arm (E). Tighten a nut halfway down on bolt to hold parts in place with Wrench and Hex Key (X). Follow these steps to assemble the second Armrest (D) to Swing Arm (E). Tighten all bolts left loose throughout the assemble of the swing seat using Wrench and Hex Key (X). Place covers over bolt-heads to hide their appearance.

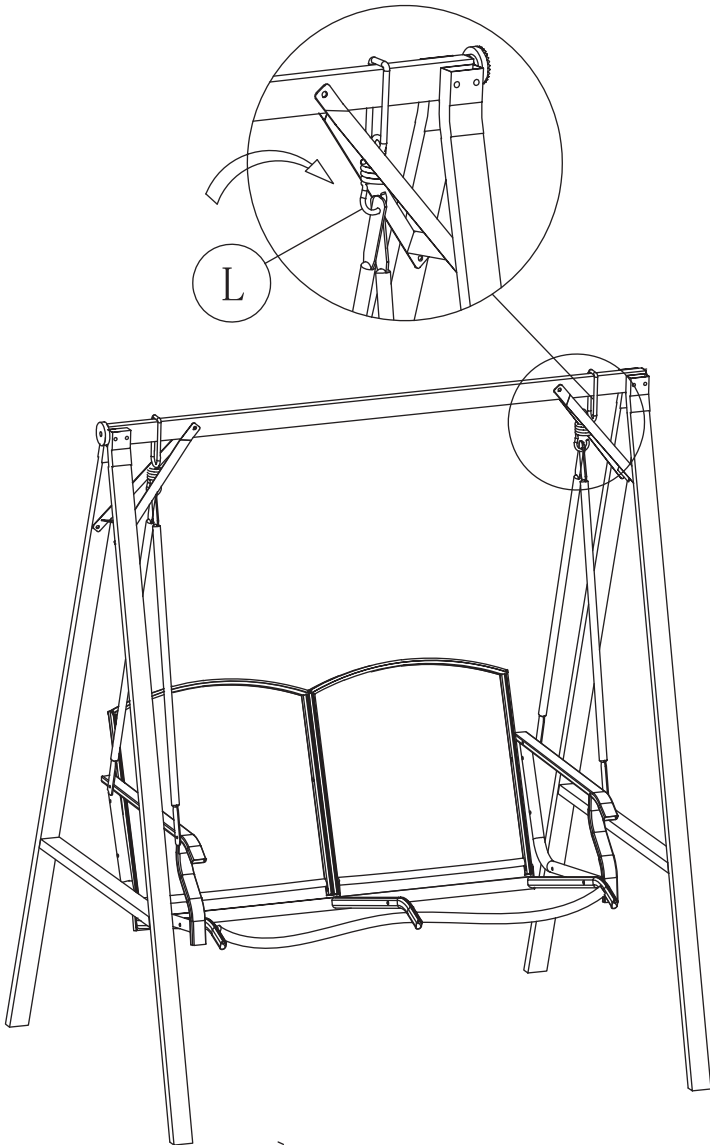

Step 7:

Place one end of Hook (L) through the opposite ends of both Swing Arms (E & F) on both sides of the swing seat. Place the opposite ends of Hooks (L) through the U-shaped loops of Swing Support (C).

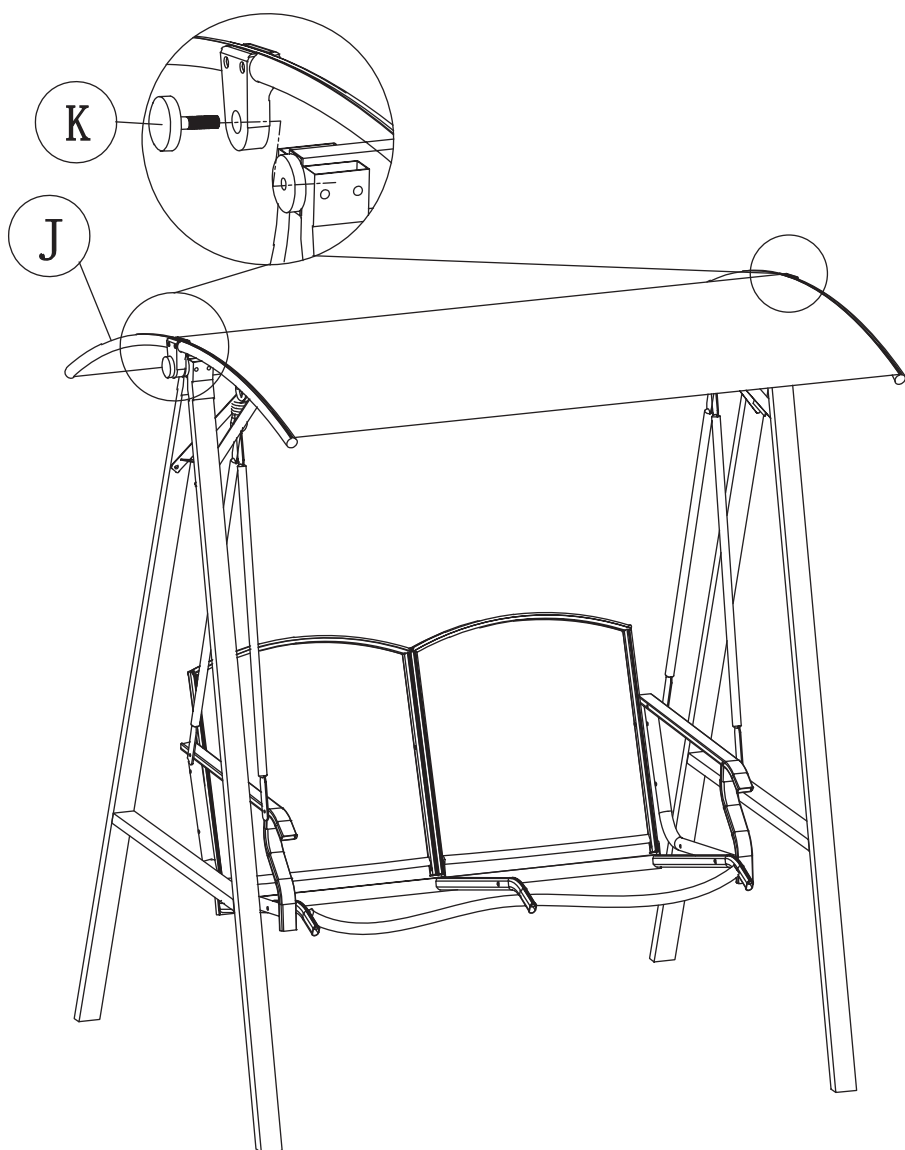

Step 8:

Unfurl the Canopy (J) and stretch it out over Swing Support (C). Insert Dials (K) through the holes found at the center of canopy bars and into the ends of Swing Support (C). Adjust the canopy to your preference and tighten Dials (K) down to hold Canopy (J) in place. Your swing set is ready to use

Two Person Swing

Steel Frame with Powder Coating

Dist. by TDC USA, Inc. Fairfield, NJ 07004
©2020 All Rights Reserved. Made in China.
Item #21636

Questions and Comments
1-800-599-8898 (9 am - 5 pm EST)
www.tdcusainc.com