

# 2-Person Sling Glider Rocker Instructions

Item #22117

Parts List		
A		1 pc
B		1 pc
C		2 pcs
D		1 pc
E		2 pcs
F		12 pcs
G		2 pcs
H		2 pcs
I		16 pcs
J		16 pcs
K		1 pc

## STEP 1

Insert ends of Armrest (A) into brackets on the top of Rocker Bar (C). Insert two Bolts M6x12 (F) with Washers (I) through each end of Armrest (A) and into the screw-threading of brackets of Rocker Bar (C); see Fig. 1. Follow these steps to assemble Armrest (B) with second Rocker Bar (C).

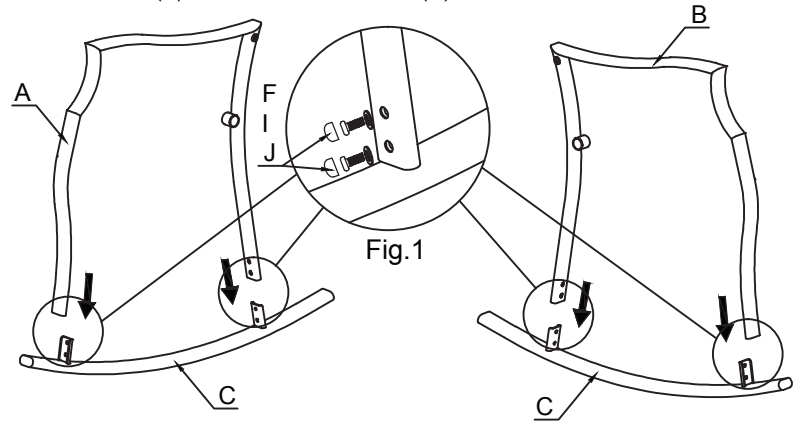

## STEP 2

Unfold Seat (D) as illustrated here.

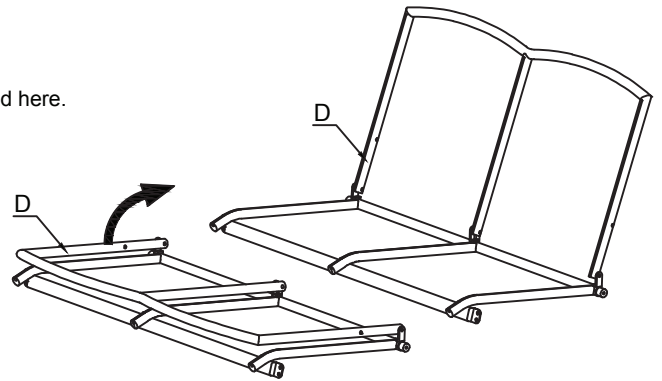

## STEP 3

Place assembled Armrest (B) with Rocker Bar (C) against Seat (D) as illustrated here. Insert one Bolt M6x40 (H) with Washer (I) through frame of seat back of part D and into the screw-threading found at the corner where the armrest and rear-leg meet of part B; see Fig. 2. It is advised to not tighten bolts all the way down until assembly of both Armrests (A&B) with Rocker Bars (C) to Seat (D) is completed.

Insert one Bolt M6x20 (G) with Washer (I) and Spacer (E) into the screw-threading where the seat and seat back meet of part D.

Insert two Bolts M6x12 (F) with Washers (I) through end of front support bar of Seat (D) and into the screw-threading found on the front-leg of Armrest (B). Follow these steps to assemble Armrest (A) with Rocker Bar (C) against opposite side of Seat (D). Tighten all bolts left loose through out assemble process once both armrests have been secured to both sides of seat. Place Caps (J) over bolt-heads to hide their appearance.

