

UTV Quad

Battery Powered Electric Ride-On



Owner's Manual with Assembly Instructions

Made in China.

The owner's manual contains important safety information as well as assembly, use and maintenance instructions. The Ride-on must be assembled by an adult who has read and understands the instructions in this manual. Keep the packaging and bags away from children and dispose of all packaging properly before use. Keep this manual for future reference.



**PLEASE DO NOT
RETURN THIS
PRODUCT
TO THE STORE**

We will be happy to correct any problems that you may have, or answer any of your questions regarding the purchase of this product. Please contact us at our Toll Free customer service number 1-800-599-8898 for any assistance and replacement parts.

Please keep your sales receipt which may be request when seeking assistance.

Thank You.

Dist. by TDC USA, Inc. Fairfield, NJ 07004

©2021 All Rights Reserved.

Made in China.

Item 60621

www.tdcusainc.com

1 YEAR LIMITED WARRANTY SIX MONTH LIMITED WARRANTY ON BATTERY

6-months warranty applies only to the 12-volt battery which is included by TDC USA Inc. with the vehicle when it was originally purchased. This warranty covers normal use and does not cover the vehicle or battery if damaged by unreasonable use, neglect, abuse, accident, misuse, improper service or other causes not arising out of defects in material or workmanship. Evidence of any attempt at consumer repair will void this warranty.

Warranty services are provided by TDC USA Inc. If a hardware defect arises and a valid claim is received during the warranty period, TDC USA Inc. will repair the hardware defect by using new or refurbished parts that are equivalent to new in performance and reliability. This warranty is for 1 replacement only of like-items and does not cover items out of production if the product is no longer made or stocked. This warranty is not assignable or transferable. This warranty covers factory defects only. This warranty will not cover labor, return shipping or the shipping expense to you. The warranty does not cover misuse or broken parts caused by the user or by any other event. If we verify a parts defect, we will repair or replace the part, yet you must pay for our labor to do so at our then current rates (if you do not re-install the part yourself). TDC USA INC. will not be responsible for shipping charges on received or refused packages, part returns, or scooter returns. In the event of a verified warranty claim, we will reimburse you for shipping and we will repair or replace the defective part. However, you must arrange and pay for shipping and you bear the risk of loss and damage for the scooter or part being shipped back to us.

CONDITIONS OF WARRANTY:

The user assumes all risk of personal injuries, damage to, or failure of the Vehicle and any other losses if the Vehicle is altered in any way or if the Vehicle is used for stunt riding, ramp jumping, aerobatics or similar activities, or is towed by another person or vehicle.

THIS WARRANTY DOES NOT COVER ANY DAMAGE DUE TO THE FOLLOWING:

- Transportation
- Storage
- Improper use
- Failure to follow the product instructions or perform any preventive maintenance
- Modifications
- Unauthorized repair
- Normal wear and tear
- External causes such as accidents, abuse, or other actions or events beyond our reasonable control
- Used as a rental
- Weather related water damage is determined
- Minor surface blemishes, rips, tears, or other cosmetic damages due to normal use, or other intentional or unintentional damage to the product.
- Any damage which results from aging, such as fading of paint, deterioration of plated surfaces, deterioration of rubber or plastics, or rusting.

DO NOT DISASSEMBLE THE PRODUCT.

Doing so will void this warranty. Only TDC USA Inc. is the authorized service center who should perform service on this product.



Warning: Changes or modifications to this unit not expressly approved by the party responsible for compliance could void the user's authority to operate the equipment.

OWNER'S WARRANTY RESPONSIBILITIES:

As the device's owner, you are responsible for the performance of the required maintenance. You may be denied a warranty claim solely because of your failure to ensure the performance of all scheduled maintenance. As the owner, you should be aware that you may be denied your warranty coverage if your device or a part has failed due to abuse, neglect, improper maintenance, or unapproved modifications. For any issue regarding your ATV, call toll free 1-(888) 599-8898, or email support@tdcusainc.com

- This ride-on car will provide your child with many miles of riding of enjoyment. To help assure you and your rider a safe ride we ask you to please read this manual carefully, and keep it for future reference.
- Follow the recommendations in this manual, they are designed to improve the safety and operation of your ride-on car and it's rider.

WARNING!

• **CHOKING HAZARD** - Small parts. Not suitable for children under 36 months. The product contains small parts, keep children away when assembling.

• **ADULT ASSEMBLY REQUIRED.**

Always remove protective material and poly bags and dispose before assembly.

• **Assembly tools required:**



Screwdriver
(Not Included)



Long nose pliers
(Not Included)



Spanner
(Included)



Approximate
Assembly Time:
30 Minutes

Specifications

Age	3+ years
Weight Capacity	Max 110 lbs
Speed	Min 1.6mph / Max 3.7 mph
Overall Dimensions	48.8"x32.5"x31.8"
Charge Time	8-12 hours
Battery	12V 7AH
Charger	12V 900mA

SAFETY

THE FOLLOWING SAFETY HAZARDS MAY RESULT IN SERIOUS INJURY OR DEATH:

- This product contains small parts. Keep children away during assembly. Make sure to remove all packaging material and parts from underneath the vehicle body.
- Never open the battery. Batteries contain lead and lead compounds (acids) that are toxic and corrosive, and known to the state of California to cause cancer and reproductive harm.
- Limbs, hair, and clothing can get caught in moving parts. Always wear shoes, keep limbs away from moving parts, and do not wear loose clothing while operating this vehicle.
- This Vehicle does not have brakes or braking capability. Do not leave a child unattended during operation. Do not use this in a location that may require braking capability, as this could result in loss of control, which may cause serious injury or death.
- Use of this vehicle in unsafe conditions such as snow, rain, loose dirt, mud, sand, or gravel may result in an unexpected accident such as tipping over, and could damage the electrical system or battery.
- Do not operate this vehicle in an unsafe manner. Examples include but are not limited to:
 - Pulling the vehicle with another vehicle or similar device
 - Pushing the user
 - Traveling at an unsafe speed

BATTERY WARNINGS

THE FOLLOWING SAFETY HAZARDS MAY RESULT IN SERIOUS INJURY OR DEATH:

- Use of a battery charger other than the supplied 12V rechargeable battery and charger may cause a fire or explosion. Only use the supplied battery and charger.
- Use of the 12V rechargeable battery and charger for any other product may result in overheating, fire, or explosion. Never use the supplied rechargeable battery and charger with another product.
- Explosive gases are created during charging. Charge the battery in a well-ventilated area. Do not charge the battery near heat or flammable materials.
- Contact between the positive and negative terminals may result in fire or explosion. Avoid direct contact between the terminals. Picking up the battery by the wires or charger can cause damage to the battery and may result in a fire. Always pick up the battery by its case or handles.
- Liquids on the battery may cause fire or electric shock. Always keep all liquids away from the battery and keep the battery dry. Contact or exposure to battery leakage (lead acid) may cause serious injury. If contact or exposure occurs immediately call your physician. If the chemical is on the skin or in the eyes, flush with cool water for 15 minutes. If the chemical was swallowed, immediately give the person water or milk. Do not give water or milk if the patient is vomiting or has a decreased level of alertness. Do not induce vomiting.
- Battery posts, terminals, and related accessories contain lead and lead compounds (acid) - chemicals known to the state of California to cause cancer, reproductive harm, and are toxic and corrosive. Never open the battery.
- Tampering or modifying the electric circuit system may cause a shock, fire or explosion and permanently damage the system. Exposed wiring and circuitry in the charger may cause electric shock. Always keep the charger housing closed.

USER WARNINGS

THE FOLLOWING SAFETY HAZARDS MAY RESULT IN SERIOUS INJURY OR DEATH:

- Never leave a child unattended.
- Always sit in the seat when using this vehicle.
- Keep your hands, hair, and cloths away from moving parts.
- Always wear shoes when operating this vehicle.
- Two Max riders are allowed on the vehicle at a time.
- Children under 3 years of age cannot use the vehicle.
- Only drive on level ground.
- Do not go near swimming pools or other bodies of water, drop-offs or up and down steep inclines.
- Do not drive the vehicle into loose dirt, mud, sand, fine gravel, or on wet surfaces.
- Do not drive the vehicle on streets or near cars.



WARNING!

PREVENT INJURIES AND DEATHS:

NEVER LEAVE CHILD UNATTENDED. DIRECT ADULT SUPERVISION IS REQUIRED.

- Always keep child in view when child is in vehicle.
- This toy should be used with caution since skill is required to avoid falls or collisions causing injury to the user or third parties.
- Protective equipment should be worn.
- Never use in roadways, near cars, on or near steep inclines or steps, swimming pools or other bodies of water.
- Always wear shoes.
- Always sit on the seat.
- Not to be used in traffic.
- This toy is unsuitable for children under 3 years old due to its maximum speed; Maximum user weight is 110lbs or combine 110lbs for 2 users
- This toy has no brake.
- Never allow more than two riders.

RULE FOR SAFE RIDING

KEEP CHILDREN WITHIN SAFE RIDING AREAS:

- Never use in roadway, near motor vehicles, on lawn space, on or near steep inclines or steps, swimming pools or other bodies of water;
- Use the toy only on flat surfaces. Such as inside your house, garden or playground.
- Never use in the dark. A child could encounter unexpected obstacles and have an accident. Operate the vehicle only in the daytime or a well-lit area.
- It is prohibited to change the circuit or add other electric parts
- Inspect wires and connections of the vehicle periodically.
- Do not let any child touch the wheels or be near them when the car is moving.
- This vehicle has adjustable play seat belts. Please instruct children how to tie the safety belt before using, guarantee the security.



Use the vehicle on
generally level ground ONLY!



DO NOT Use
the vehicle over wet surfaces!

PART NO.	PART NAME	QUANTITY (PCS)
1	Vehicle Body	1
2	Gear Box	2
3	Front Wheel/Rear Wheel	4
4	Ø12 Washer	8
5	Lock Nut	4
6	Hubcap	4
7	Windshield	1
8	Seat	1
9	Rear Light Bar	1
10	Rear Axle	1
11	Steering Wheel	1
12	M5X45 Machine Screw	1
13	Ø5 Nut	1
14	Charger	1
15	Ø4x16 Screw	2
16	Front Axle	1
17	Hex Wrench	2
18	Spanner	2
19	Ø10 Plastic Washer <i>(Not shown in parts diagram)</i>	1
20	Ø8 Plastic Washer <i>(Not shown in parts diagram)</i>	8
21	Split Pin <i>(Not shown in parts diagram)</i>	1

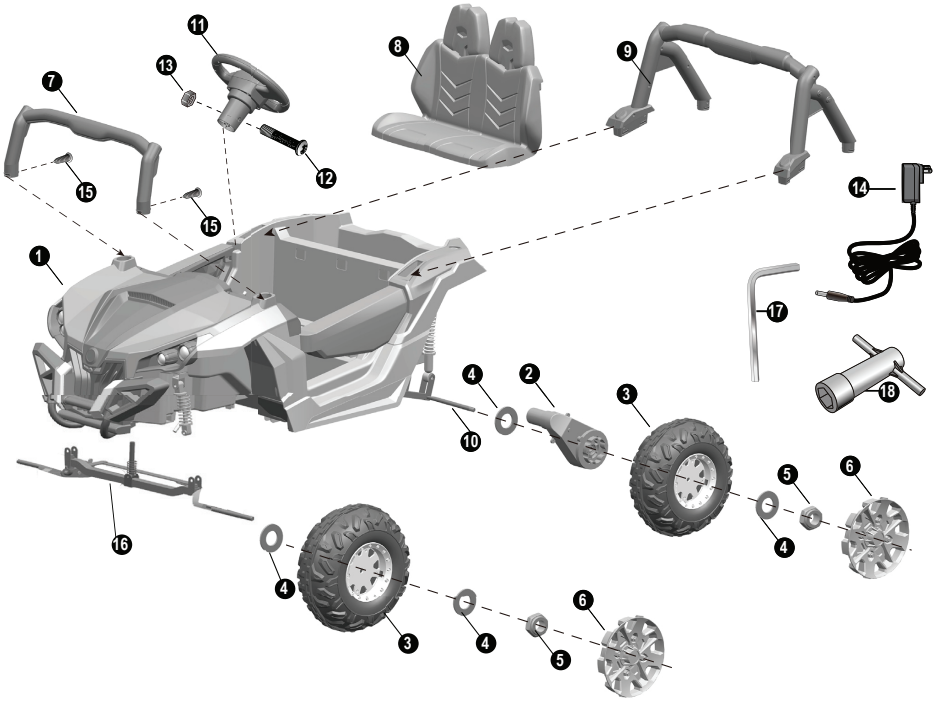

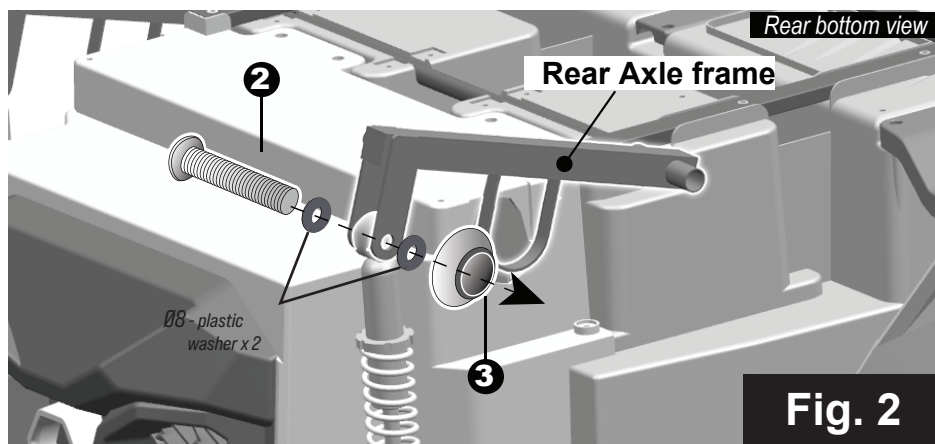
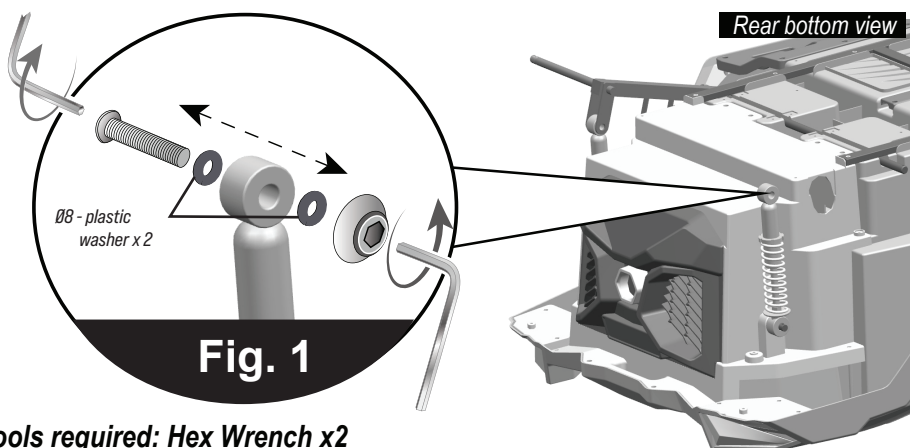

Turn the vehicle body upside down

1. Remove the **Screws** and the **Nuts** from the **Rear Shock Absorbers** with two **Hex Wrenches** (Fig. 1)
2. Line up the holes on the **Rear Axle Frame** with the holes on the **Rear Shock Absorber**, reinsert the **Screw**, and fasten the **Nut** on the opposite side. (Fig. 2)

Rear bottom view

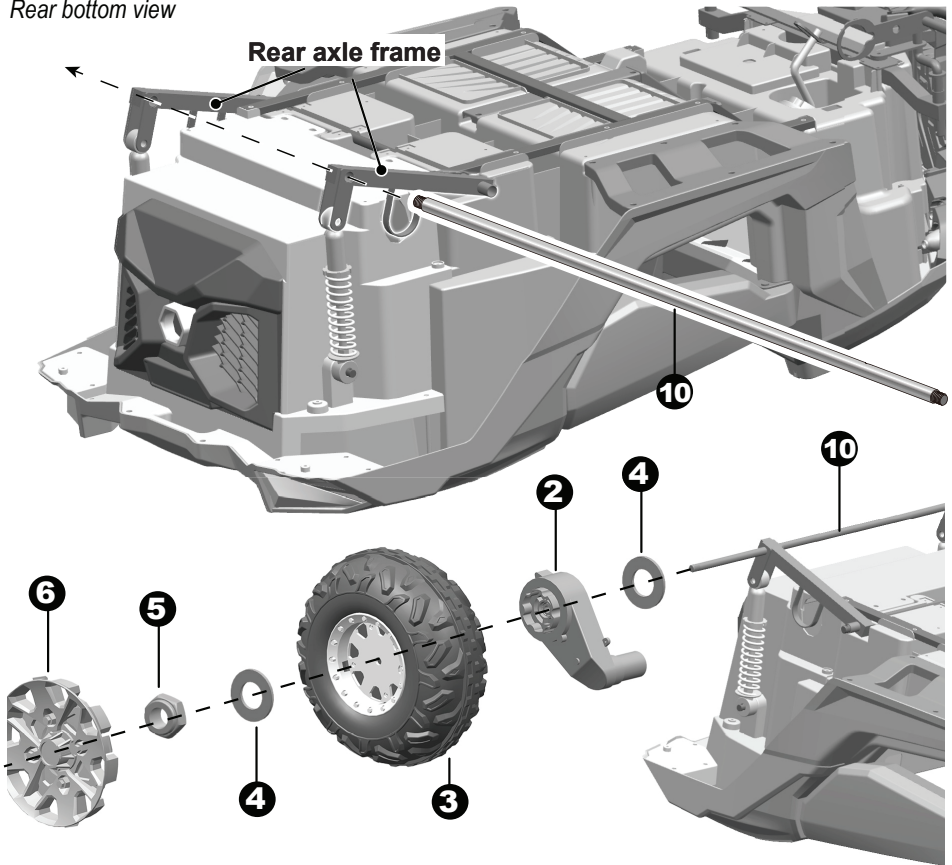

- Cut off the plastic ties on the rear axle frames with a scissors.

- Release the gear boxes,

- **DO NOT** disconnect the connectors of the gear boxes.

1. Insert the **Rear Axle (10)** into holes on the **Rear Axle frames**.
2. Slide a **Ø12 Washer (4)** onto the **Rear Axle**.
3. Slide the **Gear Box (2)** onto the **Rear Axle**.
4. Slide the **Wheel (3)** onto the **Rear Axle**. Ensure the **Wheel (3)** matches up with the **Gear Box (2)**.
5. Slide another **Ø12 Washer (4)** onto the **Rear Axle**.
6. Tighten a **Lock Nut (5)** to the end of the **Rear Axle** with a **Spanner (18)**.
7. Repeat the above procedure to assemble the other **Rear Wheel** to the **Rear Axle**.

HINT: An extra spanner has been provided to hold the Lock Nut on the other side of the rear axle while tightening the Lock Nut on the other side.

8. Insert the tabs on the **Wheel Cover (6)** into the slots on the **Wheel (3)**.

Turn the vehicle body upside down.

1. Remove the **Lock Nut (5)** and **Ø12 Washer (4)** on the **Front Axle (16)**. Fit the **Front Axle (16)** to the front of the **Vehicle Body (1)**
2. Insert the bent end of the **Steering Column** into the hole on the **Front Axle Linkage**. Fit a **Ø10 Plastic Washer (19)** to the bent end of the **Steering Column** and insert a **Split Pin (21)** into the hole on the **Steering Column**, bend the ends of **Split Pin (21)** back using **Long Nose Pliers (not included)**. (Fig. 3)

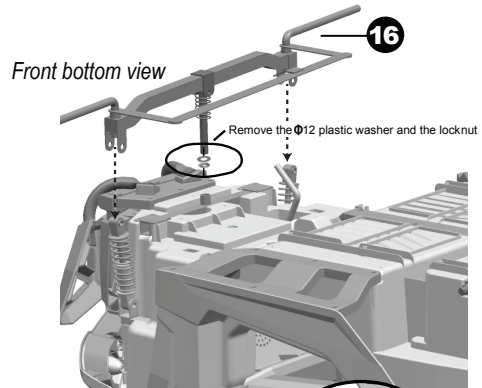

3. Remove the **Screws, Ø8 Plastic Washers (x2)** and the **Nuts** from the **Front Shock Absorbers** with two **Hex Wrenches**. Line up the holes on the **Front Axle Frame** with the holes on the **Front Shock Absorber**, and reinsert the **Screw, Ø8 Plastic Washers (x2)** and fasten the **Nut** on the opposite side. (Fig. 4)

4. Repeat for the other side. (Fig. 4)
Turn Vehicle Body (1) over.

5. Press the button located at the front of hood and lift up the hood. Slide a **Ø12 Washer (4)** and tighten a **Lock Nut (5)** with a **Spanner (18)**. (Fig. 5)

HINT: You may tighten the nuts on the shock absorber to adjust the tightness of the shock absorbers.

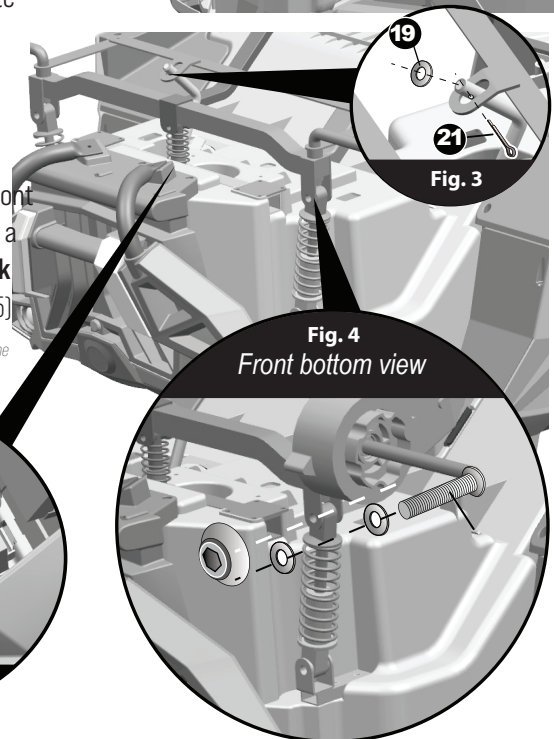
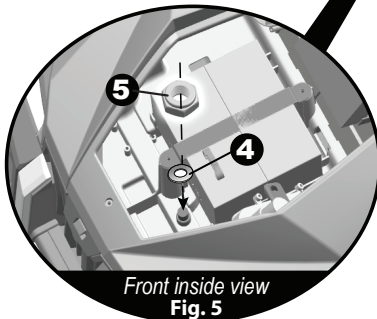

Front bottom view

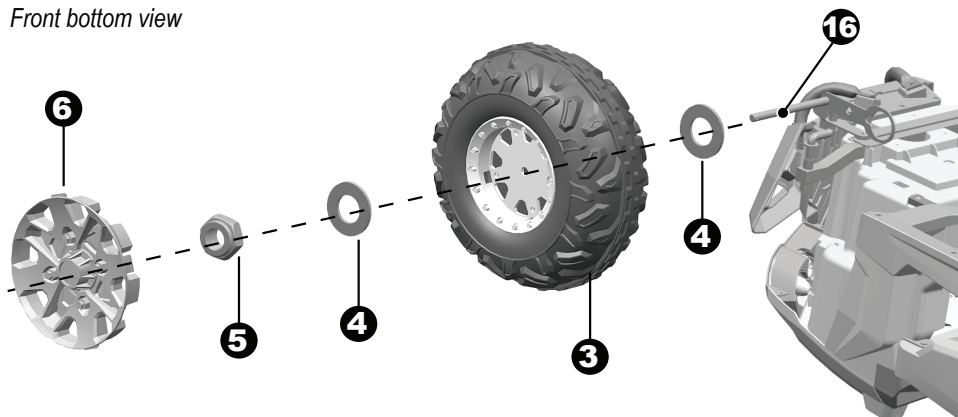

Turn the vehicle body upside down

1. Slide a $\varnothing 12$ Washer (4) and a Front Wheel (3) onto the Front Axle (16).
2. Then slide a $\varnothing 12$ Washer (4) onto the Front Axle (16).
3. Tighten a Lock Nut (5) to the end of the Front Axle (16) with a Spanner (18). **DO NOT over tighten.**
4. Insert the tabs on the Wheel Cover (6) into the slots on the Front Wheel (3).
5. Repeat the above steps 1-4 for the other wheel.
6. Turn the vehicle body over.
7. Plug the sound unit connector on the Steering Wheel (11) into the connector on the vehicle body. (Fig. 6)
8. Fit the Steering Wheel (11) to the end of the Steering Column.
9. M5x45 Machine Screw (12) and Lock Nut (13) are pre-assembled on Steering Wheel (11). Remove machine screw and lock nut from Steering Wheel (11) using screwdriver.
10. Line up the holes on the steering wheel with the holes on the Steering Column, insert the M5x45 Machine Screw (12).
11. Fasten a $\varnothing 5$ Nut (13) on the opposite end of the Screw with a Screwdriver.

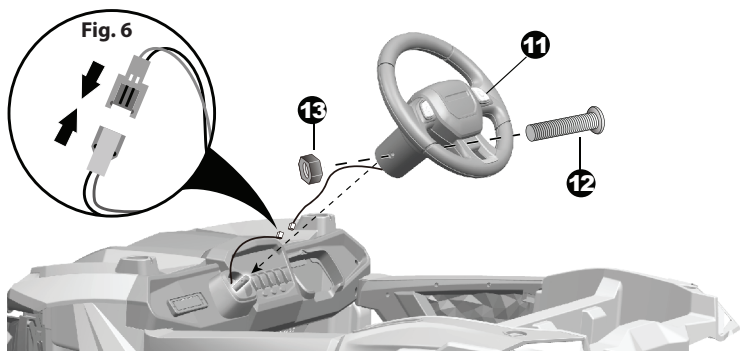

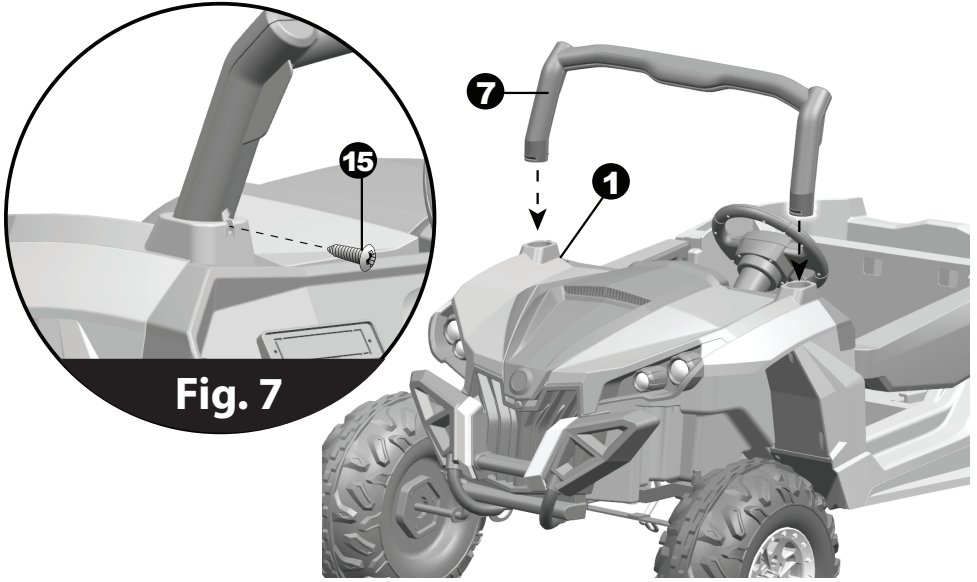

1. Insert the tabs of the **Windshield (7)** into the holds on the **Vehicle Body (1)**. Push until you hear it “snap” into place.
2. Insert two **Ø4x16 Screws (15)** through the **Vehicle Body (1)** and into the **Windshield (7)** and tighten with a **Screwdriver**. (Fig. 7)
3. Insert the tabs on the **Rear Light Bar (9)** into the opening on the **Rear of Vehicle**, and push until you hear it “click” into place.

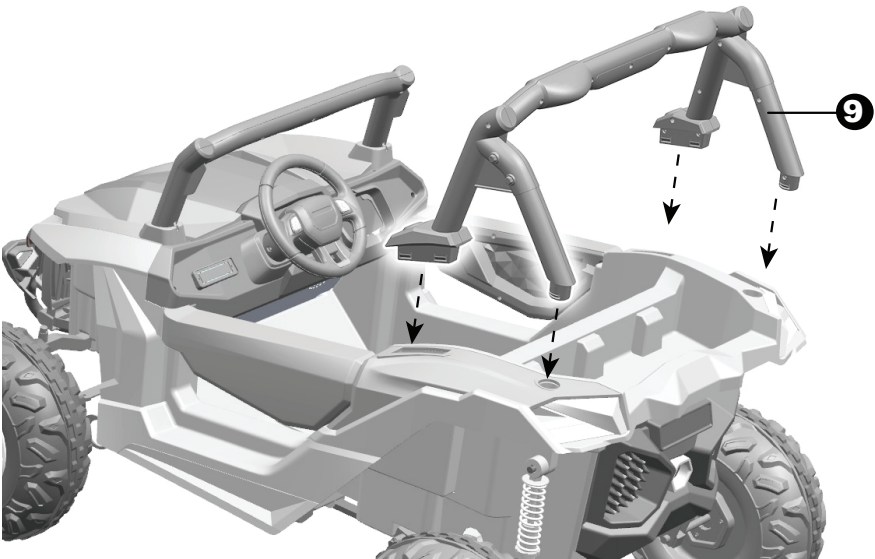

1. Align the slide strip under the **Seat (8)** with the slide way on the top of seat base, press the button located at the front of the seat base (Fig. 8) till the tabs on the back of **Seat (8)** inserted into the holes on the vehicle.

HINT: The seat is adjustable and has three position. You can move the seat back as your child grows.

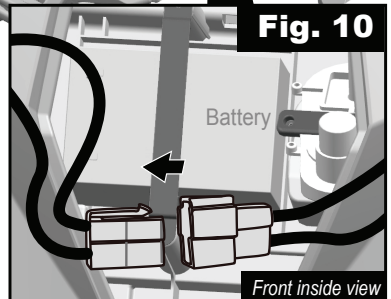
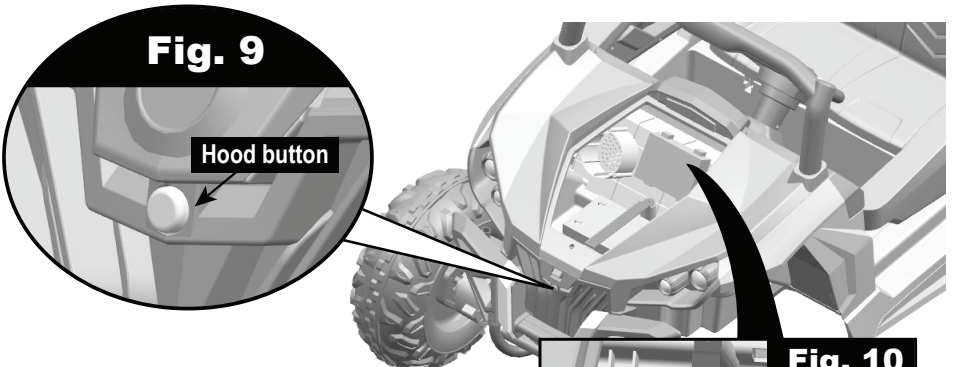
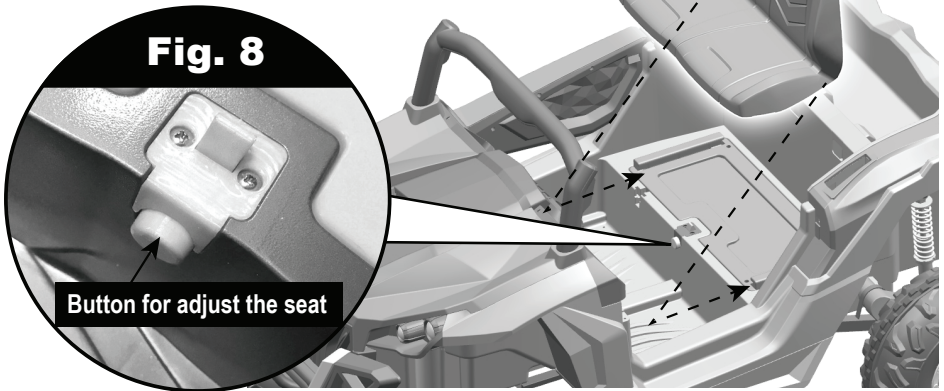

2. Press the button located at the front of hood and lift up the hood. (Fig. 9)
3. Plug the red power connector into the red terminal on the battery. (Fig. 10)
4. Close the hood.

**IMPORTANT!**

Always stop vehicle when changing the speed or direction to avoid damage the gears and motor.

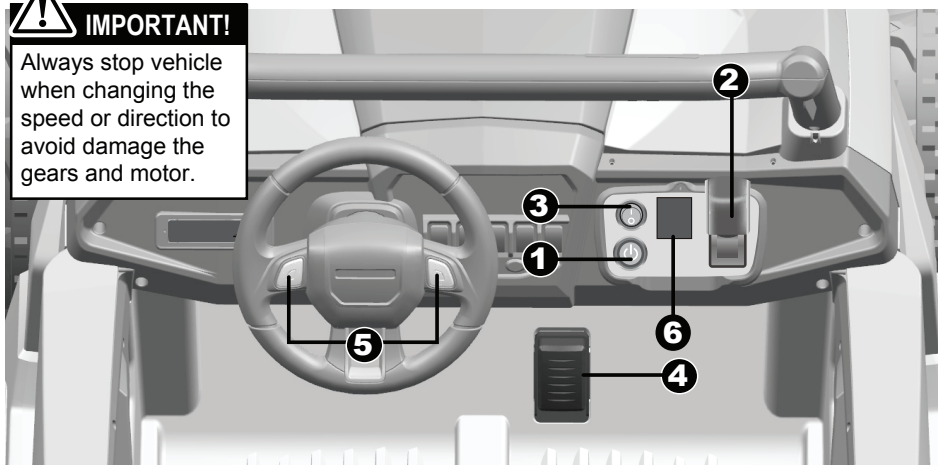

1. **Start Button:** Turns vehicle on and off
2. **Forward / Reverse Lever:** Changes the direction that vehicle moves from forward to reverse
3. **Light Switch:** Turns lights on and off
4. **Foot Pedal:** To move the vehicle, press the pedal down. To brake or slow down, release pressure from the pedal.
5. **Horn Sound Button:** Press for sound and horn playing.
6. **High-low speed switch:** Change the vehicle moves in high speed and low speed.

**WARNING!**

MAKE SURE YOUR CHILD KNOWS HOW TO STEER, HOW TO START AND STOP THE VEHICLE AND KNOWS THE RULES FOR SAFE DRIVING. THE VEHICLE CAN BE DRIVEN AT A MAXIMUM OF

3.7 MPH.

- The POWER SWITCH must be turned in "OFF" position when charging.
- Before the first use, you should charge the battery for 4-6 hours. Do not recharge the battery for more than 10 hours to avoid overheating the charger
- When the vehicle begins to run slowly, recharge the battery.

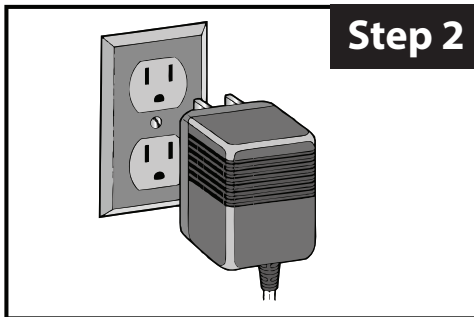
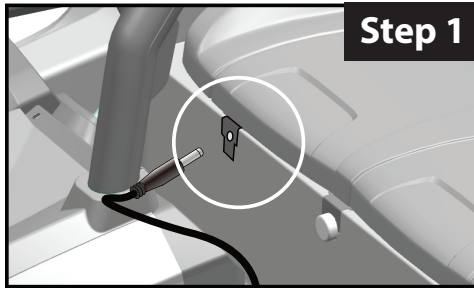

- Plug the charger port into the input socket. (below the seat)
- Plug the charger plug into a wall outlet. The battery will begin charging



WARNING!

THIS PRODUCT WITH CHARGING SAFETY PROTECTION: WHEN CHARGING, ALL FUNCTIONS WILL BE CUT OFF! ONLY AN ADULT CAN CHARGE AND RECHARGE THE BATTERY!

ONLY AN ADULT CAN CHARGE AND RECHARGE THE BATTERY!**WARNING!****PREVENT FIRE AND ELECTRIC SHOCK:**

- Use the only rechargeable battery and charger supplied with your vehicle. NEVER substitute the battery or the charger with another brand. Using another battery or charger may cause a fire or explosion.
- Do not use the battery or charger for any other product. Overheating, fire or explosion could occur.
- NEVER modify the electric system. Tampering with the electric system may cause a shock, fire or explosion or may permanently damage system.
- Do not allow direct contact between battery terminals. Fire or explosion can occur.
- Do not allow any type of liquid on the battery or its components.
- Explosive gases are created during charging. Do not charge near heat or flammable materials. Charge the battery in a well-ventilated area ONLY.
- NEVER pick up the battery by the wires or charger. Damage can occur to the battery and may cause a fire. Pick up the battery by the case ONLY.
- Charge the battery in a dry area ONLY.
- Battery posts, terminals and related accessories contain lead and lead compounds, chemicals known to the State of California to cause cancer and reproductive harm. **Wash hands after handling.**
- Do not open the battery. Battery contains lead acid and other materials that are toxic and corrosive.
- Do not open the charger. Exposed wiring and circuitry inside case may cause electric shock.
- Only adults may handle or charge the battery. NEVER allow child to handle or charge the battery. Battery is heavy and contains lead acid. (electrolyte).
- Do not drop the battery. Permanent damage to the battery could occur or cause serious injury.
- Before charging the battery, check for wear or damage to the battery, charger, its supply cord and the connectors. DO NOT charge the battery if any damage to parts has occurred.
- Do not allow the battery to drain completely. Recharge the battery after each use or once a month if not used regularly.
- Do not charge the battery upside down.
- Always secure the battery with the bracket. Battery can fall out and injure a child if vehicle tips over.

The POWER SWITCH must be turned in OFF position when charging.

Before the first use, you should charge the battery for 4-6 hours. Do not recharge the battery for more than 10 hours to avoid overheating the charger.

When the vehicle begins to run slowly, recharge the battery.

After each use or once a month minimum recharge time as 8 to 12 hours, less than 20 hours at most.

The battery features a thermal fuse with a reset fuse that will automatically trip and cut all power to the vehicle if the motor, electric system or battery is overloaded. The fuse will reset and power will be restored after the unit is turned OFF for 20 seconds and then turned ON again. If the thermal fuse trips repeatedly during normal use, the vehicle may need repair. **Contact your distributor please.**

To avoid losing power, follow these guidelines:

- Do not overload the vehicle.
- Do not tow anything behind the vehicle.
- Do not drive up steep slopes.
- Do not drive into fixed objects, which may cause the wheels to spin, causing the motor to overheat.
- Do not drive in very hot weather, components may overheat.
- Do not allow water or other liquids to come in contact with the battery or other electric components.
- Do not tamper with the electric system. Doing so may create a short, causing the fuse to trip.

Battery Disposal



Recycle the dead battery responsibly. The battery contains lead acid (electrolyte) and must be disposed of properly and legally. It is illegal in most areas to incinerate lead acid batteries or dispose of them in landfills. Take it to a federal or state-approved lead acid battery recycler, such as local automotive battery retailer. Do not throw the battery away with your regular household waste!

Problem	Possible Cause	Possible Cause
Vehicle does not run	Battery low on power	Recharge battery. After each use, or once a month minimum, charge the battery for a 'full' 8 to 12 hours. DO NOT leave the battery on the charger for more than 20 hours.
	Thermal fuse has tripped	Replace thermal fuse with new fuse. (See thermal fuse)
	Battery connector or wires are loose	Check that the battery connector is firmly plugged into the motor connector.
	Battery is dead	Replace battery. Please call us at 1-800-599-8898 for battery replacement.
	Electrical system is damaged	Check to see if water may have corroded the system. Loose dirt, gravel or sand might have jammed the switch.
	Motor is damaged	Please call us at 1-800-599-8898.
Vehicle does not run very long	Battery is under charged	You may not be charging the battery long enough. After each use, or once a month minimum, charge the battery for a 'full' 8 to 12 hours. DO NOT leave the battery on the charger for more than 20 hours.
Loud grinding or clicking noises coming from motor or gear box	Motor or gears are damaged	Please call us at 1-800-599-8898.
Vehicle runs sluggishly or beeping occurs	Vehicle is overloaded	Reduce weight on vehicle. Do not overload the vehicle. Only one rider at a time. Maximum user weight is 110lbs.
	Vehicle is being used in harsh conditions	Operate the vehicle on level ground and firm surfaces.
Vehicle needs a push to go forward	Poor contact of wires or connectors	Check that the battery connector is firmly plugged into the motor connector. If wires are loose around the motor please call us at 1-800-599-8898.
	"Dead Spot" on motor	A dead spot means the electric power is not being delivered to the terminal connection and the vehicle needs repair. Call us at 1-800-599-8898.
6V Battery will not recharge	Battery connector or adapter connector is loose	Check that battery connectors are firmly plugged into each other.
	Charger not plugged in	Check that battery charger is plugged into a working wall outlet.
Battery bubbles or gurgles when charging	This is normal and not a cause for concern	
Charger feels warm when recharging	This is normal and not a cause for concern	

COMPLETELY READ THROUGH THIS MANUAL AND THE TROUBLESHOOTING GUIDE TABLE BEFORE CALLING. IF YOU STILL NEED HELP RESOLVING THE PROBLEM YOU CAN CALL US AT 1-800-599-8898

- It is parents' responsibility to check main parts of the toy before using. Regular examination of transformer or battery charger for any damage to their cord, plug, enclosure and other parts, and that, in the event of such damage, toy must not be used with the transformer or battery charger until such damage has been repaired.
- Make sure the plastic parts of the vehicle are not cracked or broken.
- Park the vehicle indoors or cover it with a tarp to protect it from wet weather.
- Keep the vehicle away from sources of heat, such as stoves and heaters. Plastic may melt.
- Recharge the battery after each use. Only an adult can handle the battery. Recharge the battery at least once a month when the vehicle is not being used.
- Do not wash the vehicle with a hose. Do not wash the vehicle with soap and water. Do not drive the vehicle in rainy or snowy weather. Water will damage the motor, electric system and battery.
- Clean the vehicle with a soft, dry cloth. To restore shine to plastic parts, use a non-wax furniture polish. Do not use car wax. Do not use abrasive cleaners.
- Do not drive the vehicle in loose dirt, sand or fine gravel which could damage the moving parts, motors or the electric system.
- When not using, all the electrical source should be turned off. Turn off the power switch and disconnect the battery connection.

UTV Quad

Battery Powered Electric Ride-On

Dist. by TDC USA, Inc. Fairfield, NJ 07004
©2021 All Rights Reserved. Made in China.
Item #60621

Questions and Comments
1-800-599-8898 (9 am - 5 pm EST)
www.tdcusainc.com

This products meets ASTM F963 and CPSIA requirements for electric vehicles.