

greenworks

proTM

**ST60L03
ST60L413**

**ULTRAPOWER™
60V**

EN STRING TRIMMER

OPERATOR MANUAL

ES CORTABORDES

MANUAL DEL OPERADOR



STC456

www.greenworkstools.com

1	Description.....	4	9.3	Adjust the length of the cutting line.....	8
1.1	Purpose.....	4	9.4	Adjust the cutting diameter.....	9
1.2	Overview.....	4	9.5	Line cut-off blade.....	9
1.3	Packing list.....	4	9.6	Attach machine to shoulder strap.....	9
2	Important safety instructions.....	4	9.7	Operation tips.....	9
3	Symbols on the machine.....	5	9.8	Cutting tips	10
4	Risk levels.....	6	10	Maintenance.....	10
5	Service.....	6	10.1	General information.....	10
6	Environmentally safe battery disposal.....	6	10.2	Clean the machine.....	10
7	Proposition 65.....	6	10.3	Replace excess line.....	10
8	Installation.....	7	10.4	Install the cutting line.....	11
8.1	Unpack the machine.....	7	10.5	Replace the spool.....	12
8.2	Attach the guard.....	7	10.6	Remove the trimmer head.....	12
8.3	Assemble the shaft.....	7	10.7	Assemble the trimmer head.....	12
8.4	Attach the auxiliary handle.....	7	11	Transportation and storage.....	13
8.5	Install the battery pack.....	8	11.1	Move the machine.....	13
8.6	Remove the battery pack.....	8	11.2	Store the machine.....	13
9	Operation.....	8	12	Technical data.....	13
9.1	Start the machine.....	8	13	Troubleshooting.....	13
9.2	Stop the machine.....	8	14	Limited warranty.....	14
			15	Replacement parts.....	15

1 DESCRIPTION

1.1 PURPOSE

This machine is used to cut grass, light weeds, and other similar vegetation at or around ground level. The cutting plane must be approximately parallel to the ground surface. You cannot use the machine to cut or chop hedges, shrubs, bushes, flowers and compost.

1.2 OVERVIEW

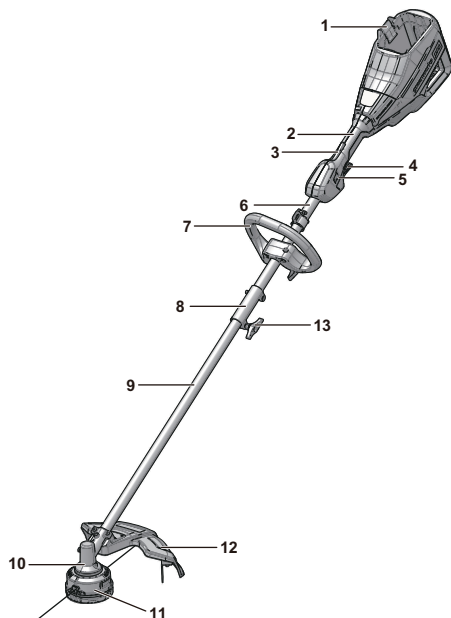

- | | |
|----|------------------------|
| 1 | Battery release button |
| 2 | Rear handle |
| 3 | Lock-out button |
| 4 | Trigger |
| 5 | Speed switch |
| 6 | Upper shaft |
| 7 | Auxiliary handle |
| 8 | Coupler |
| 9 | Lower shaft |
| 10 | Gear box |
| 11 | Trimmer head |
| 12 | Guard |
| 13 | Knob |

1.3 PACKING LIST

- | | | | |
|---|--------------------------|---|----------------|
| 1 | String trimmer bare tool | 4 | Allen key |
| 2 | Auxiliary handle | 5 | Manual |
| 3 | Guard | 6 | Shoulder strap |

2 IMPORTANT SAFETY INSTRUCTIONS

READ ALL INSTRUCTIONS BEFORE USING (THIS POWER TOOL)

▲ WARNING

Read and understand all instructions before using this product. Failure to follow all instructions listed below may result in electric shock, fire, and/or serious personal injury.

- Use only identical manufacturer's replacement parts and accessories. Use of any other parts may create a hazard or cause product damage.
- Always wear safety glasses with side shields marked to comply with ANSI Z87.1. Everyday glasses have only impact resistant lenses. They are NOT safety glasses. Following this rule will reduce the risk of eye injury. Use face mask if operating in dusty work spaces.
- Avoid Dangerous Environment – Don't expose power tools to damp or wet conditions. Water entering a power tool will increase the risk of electric shock.
- Don't use in rain.
- Keep all bystanders, children, and pets at least 50 ft. away.
- Dress Properly – Do not wear loose clothing or jewelry. They can be caught in moving parts. Use of rubber gloves and substantial footwear is recommended when working outdoors. Wear protective hair covering to contain long hair.
- Use right Appliance. Do not use appliance for any job except that for which it is intended.
- Avoid Unintentional Starting – Don't carry appliance with finger on switch. Be sure switch is off when battery is plugged in.
- Don't Force Appliance – It will do the job better and with less likelihood of a risk of injury at the rate for which it was designed.
- Don't overreach – Keep proper footing and balance at all times.
- Stay alert – Watch what you are doing. Use common sense. Do not operate this unit when you are tired, ill or under the influence of alcohol, drugs or medication.
- Always store idle power tools indoors – When not in use, power tools should be stored indoors in a dry and high or locked-up place, out of reach of children.
- Maintain Appliance With Care – Replace string head if cracked, chipped, or damaged in any way. Be sure the string head is properly installed and securely fastened. Keep cutting edge sharp and clean for best performance

and to reduce the risk of injury. Follow instructions for lubricating and changing accessories. Inspect appliance cord periodically, and if damaged, have it repaired by an authorized service facility. Inspect extension cords periodically and replace if damaged. Keep handles dry, clean, and free from oil and grease. Failure to do so can cause serious injury.







- Check damaged parts before using the appliance, a guard or other part that is damaged should be carefully checked to determine that it will operate properly and perform its intended function. Check for alignment of moving parts, binding of moving parts, breakage of parts, damaged mountings, and any other condition that may affect its operation. A guard or other part that is damaged should be properly repaired or replaced by an authorized service center unless indicated elsewhere in this manual.
- Remove or disconnect battery before servicing, cleaning or removing material from the gardening appliance.
- Do not modify or attempt to repair the appliance or the battery pack (as applicable) except as indicated in the instructions for use and care. Use appliances only with specifically designated battery packs. Use of any other battery packs may create a risk of injury and fire. Use only with Greenworks LB602, LB603, LB604, LB605, LB606 battery or other BAC series.
- Recharge only with the charger specified by the manufacturer. A charger that is suitable for one type of battery pack may create a risk of fire when used with another battery pack. Use only with Greenworks CAC801, CH60DP01, 60DPC10A, CH60R00 charger or other CAC series.
- When battery pack is not in use, keep it away from other metal objects, like paper clips, coins, keys, nails, screws or other small metal objects, that can make a connection from one terminal to another. Shorting the battery terminals together may cause a fire.
- Under abusive conditions, liquid may be ejected from the battery; avoid contact. If contact accidentally occurs, flush with water. If liquid contacts eyes, additionally seek medical help. Liquid ejected from the battery may cause irritation or burns.
- Do not use a battery pack or appliance that is damaged or modified. Damaged or modified batteries may exhibit unpredictable behavior resulting in fire, explosion or risk of injury.
- Do not expose a battery pack or appliance to fire or excessive temperature. Exposure to fire or temperature above 265 °F (130 °C) may cause an explosion.
- Do not dispose of the batteries in a fire. The cells may explode. Check with local codes for possible special disposal instructions.
- Do not open or mutilate the batteries. Released electrolyte is corrosive and may cause damage to the eyes or skin. It may be toxic if swallowed.
- Exercise care in handling batteries in order not to short the battery with conducting materials such as rings, bracelets, and keys. The battery or conductor may overheat and cause burns.



- Follow all charging instructions and do not charge the battery pack or appliance outside of the temperature range specified in the instructions. Charging improperly or at temperatures outside of the specified range may damage the battery and increase the risk of fire.
- Have servicing performed by a qualified repair person using only identical replacement parts. This will ensure that the safety of the product is maintained.
- Keep guards in place and in working order.
- Keep hands and feet away from cutting area.
- Disconnect the battery pack from the appliance before making any adjustments, changing accessories, or storing appliance. Such preventive safety measures reduce the risk of starting the appliance accidentally.
- Use only with the nylon cutting line of 0.095" / 0.080" (2.4 mm / 2.0 mm) diameter. Do not use heavier lines than recommended by the manufacturer and line materials of other types – for example, metal wire, rope, and the like.

SAVE THESE INSTRUCTIONS

3 SYMBOLS ON THE MACHINE



Some of the following symbols can be used on this machine. Please study them and learn their definition. Proper interpretation of these symbols will let you operate the tool better and safer.

Symbol	Explanation
V	Voltage
A	Current
Hz	Frequency (cycles per second)
W	Power
min	Time
/min	Revolutions, strokes, surface speed, orbits etc., per minute
	Direct current
	Precautions that involve your safety.
	Read and understand all instructions before you operate the machine, and follow all warnings and safety instructions.
	Always wear safety glasses with side shields marked to comply with ANSI Z87.1 when you operate this machine.
	Do not expose the machine to rain or moist conditions.
	Keep all bystanders at least 15m away.

Symbol	Explanation
	Do not install or use any type of blade on the machine or displaying this symbol.
	Thrown objects can ricochet and result in personal injury or property damage.

4 RISK LEVELS

The following signal words and meanings are intended to explain the levels of risk associated with this product.

SYM-BOL	SIGNAL	MEANING
	DANGER	Indicates an imminently hazardous situation, which, if not avoided, will result in death or serious injury.
	WARNING	Indicates a potentially hazardous situation, which, if not avoided, could result in death or serious injury.
	CAUTION	Indicates a potentially hazardous situation, which, if not avoided, may result in minor or moderate injury.
	CAUTION	(Without Safety Alert Symbol) Indicates a situation that may result in property damage.

5 SERVICE

Service requires extreme care and knowledge and must be performed only by a qualified service technician. For service we suggest you return the machine to your nearest AUTHORIZED SERVICE CENTER for repair. Use only identical manufacturer's replacement parts and accessories.

6 ENVIRONMENTALLY SAFE BATTERY DISPOSAL



The toxic and corrosive materials below are in the batteries used in this machine: **Lithium-Ion, a toxic material.**

▲ WARNING

Discard all toxic materials in a specified manner to prevent contamination of the environment. Before discarding damaged or worn out Li-ion battery, contact your local waste disposal agency, or the local Environmental Protection Agency for information and specific instructions. Take the batteries to a local recycling and/or disposal center, certified for lithium-ion disposal.

▲ WARNING

If the battery pack cracks or breaks, with or without leaks, do not recharge it and do not use. Discard it and replace with a new battery pack. **DO NOT TRY TO REPAIR IT!** To prevent injury and risk of fire, explosion, or electric shock, and to avoid damage to the environment:

- Cover the terminals of the battery with heavy-duty adhesive tape.
- **DO NOT** try to remove or destroy any of the battery pack components.
- **DO NOT** try to open the battery pack.
- If a leak develops, the released electrolytes are corrosive and toxic. **DO NOT** get the solution in the eyes or on skin, and do not swallow it.
- **DO NOT** put these batteries in your regular household trash.
- **DO NOT** incinerate.
- **DO NOT** put them where they will become part of any waste landfill or municipal solid waste stream.
- Take them to a certified recycling or disposal center.

7 PROPOSITION 65

▲ WARNING

This product contains a chemical known to the state of California to cause cancer, birth defects or other reproductive harm. Some dust created by power sanding, sawing, grinding, drilling, and other construction activities contains chemicals known to cause cancer, birth defects or other reproductive harm. Some examples of these chemicals are:

- Lead from lead-based paints;
- Crystalline silica from bricks and cement and other masonry products;
- Arsenic and chromium from chemically treated lumber.

Your risk of exposure to these chemicals varies depending on how often you do this type of work. To reduce your exposure to these chemicals, work in a well-ventilated area, and work with approved safety equipment, such as dust masks that are specially designed to filter out microscopic particles.

8 INSTALLATION

8.1 UNPACK THE MACHINE

▲ WARNING

Make sure that you correctly assemble the machine before use.

▲ WARNING

- If parts of the machine are damaged, do not use the machine.
- If you do not have all the parts, do not operate the machine.
- If the parts are damaged or missing, contact the service center.

1. Open the package.
2. Read the documentation in the box.
3. Remove all the unassembled parts from the box.
4. Remove the machine from the box.
5. Discard the box and package in compliance with local regulations.

8.2 ATTACH THE GUARD

▲ WARNING

Do not touch the cut-off blade.

1. Remove the screws from the trimmer head with a Phillips head screwdriver (not included).

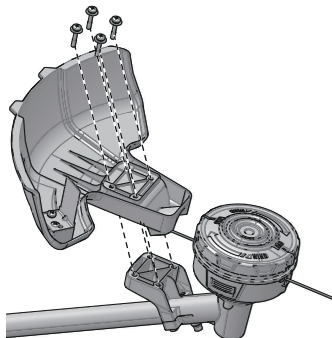

2. Put the guard onto the trimmer head.
3. Align the screw holes on the guard with the screw holes on the trimmer head.
4. Tighten the screws.

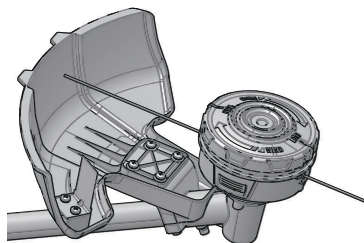

8.3 ASSEMBLE THE SHAFT

1. Loosen the knob (13) on the coupler (8).
2. Push in the release button on the lower shaft (9).

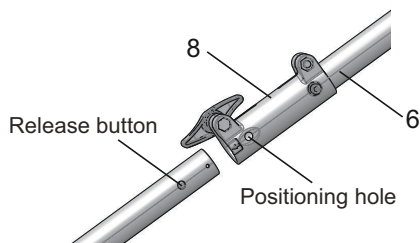

3. Align the release button with the positioning hole and move the two shafts.
4. Turn the lower shaft until the button locks into the positioning hole.
5. Tighten the knob.

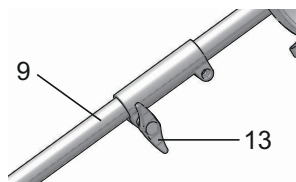

8.4 ATTACH THE AUXILIARY HANDLE

1. Remove the knob (16) from the handle.
2. Attach the auxiliary handle and lower clamp (15) on the shaft.
3. Set the auxiliary handle in the comfortable position.
4. Put the bolt (14) through the holes.
5. Tighten the auxiliary handle with the knob.

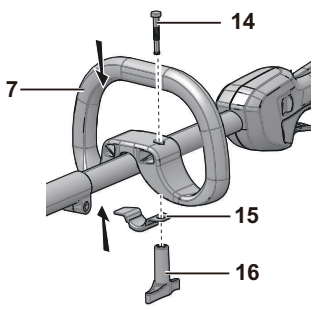

8.5 INSTALL THE BATTERY PACK

▲ WARNING

- If the battery pack or charger is damaged, replace the battery pack or the charger.
- Stop the machine and wait until the motor stops before you install or remove the battery pack.
- Read and understand the instructions in the battery and charger manual.

1. Align the lift ribs on the battery pack with the grooves in the battery compartment.
2. Push the battery pack into the battery compartment until the battery pack locks into place.
3. When you hear a click, the battery pack is installed.

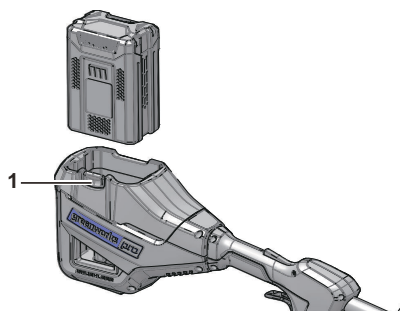

8.6 REMOVE THE BATTERY PACK

1. Push and hold the battery release button (1).
2. Remove the battery pack from the machine.

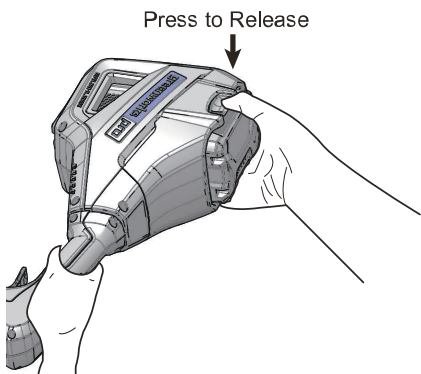

9 OPERATION

i IMPORTANT

Before you operate the machine, read and understand the safety regulations and the operation instructions.

▲ WARNING

Be careful when you operate the machine.

9.1 START THE MACHINE

1. Push the lock-out button (3) and pull the trigger (4).

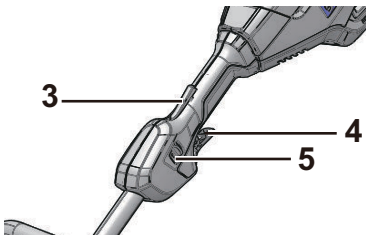

2. Push the speed switch (5) to the desired operating speed. Push the speed switch to position 1 for low speed or position 2 for high speed.

9.2 STOP THE MACHINE

1. Release the trigger to stop the machine.

9.3 ADJUST THE LENGTH OF THE CUTTING LINE

While you operate the machine, the cutting line gets worn shorter. You can adjust the length of the cutting line.

1. While the trimmer is running, bump the trimmer head against the ground.
2. Line is automatically released and the cut-off blade cuts the excess length.

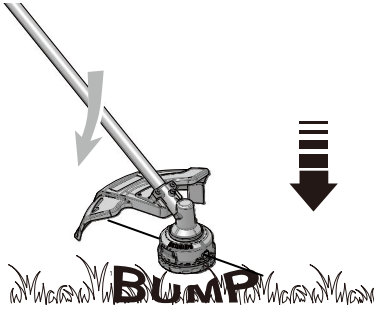

9.4 ADJUST THE CUTTING DIAMETER

i NOTE

The machine is set at a 14 in. (35.6 cm) cutting diameter. You can adjust to a 16 in. (40.6 cm) cutting diameter.

Set the cutting diameter to 14 in. (35.6 cm) for greater runtime and 16 in. (40.6 cm) for a larger cutting area.

1. Remove the battery pack.
2. Remove the blade screws from the cut-off blade (17).
3. Turn the cut-off blade 180°.
4. Tighten the blade screws with the Allen key.

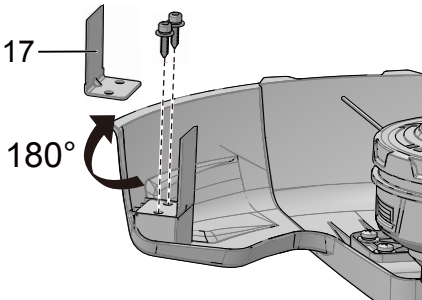

9.5 LINE CUT-OFF BLADE

This trimmer is equipped with a line cut-off blade (17) on the guard. The line cut off blade continuously trims the line to ensure a consistent and efficient cut diameter. Advance line whenever you hear the motor running faster than normal, or when trimming efficiency diminishes. This will maintain best performance and keep line long enough to advance properly.

9.6 ATTACH MACHINE TO SHOULDER STRAP

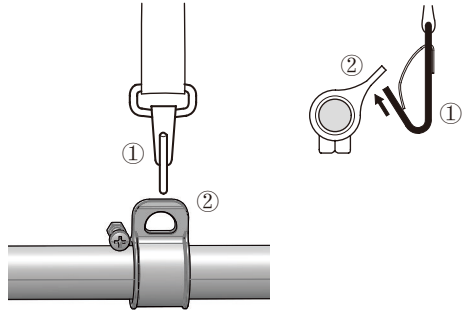

1. Attach the carabiner to the carrying ring on the drive tube.

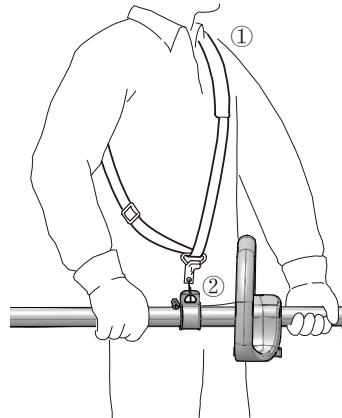

2. Put on the shoulder strap.
3. Adjust the length of the strap so that the carabiner is about a hand's width below your right hip.

9.7 OPERATION TIPS

▲ WARNING

Keep clearance between the body and the machine.

▲ WARNING

Do not operate the machine without guard in place.

Do these tips when you use the machine

- Keep a firm hold with the two hands on the machine while the string head is spinning.
- Cut tall grass from the top down.

If grass winds around the trimmer head:

- Remove the battery pack.
- Remove the grass.



9.8 CUTTING TIPS

- Tilt the machine toward the area to be cut. Use the tip of the cutting line to cut grass.
- Move the machine from right to left to prevent thrown debris from hitting the operator.
- Do not cut in the danger area.
- Do not force the trimmer head into uncut grass.
- Wire and picket fences cause cutting line wear and breakage. Stone and brick walls, curbs, and wood can wear the cutting line quickly.

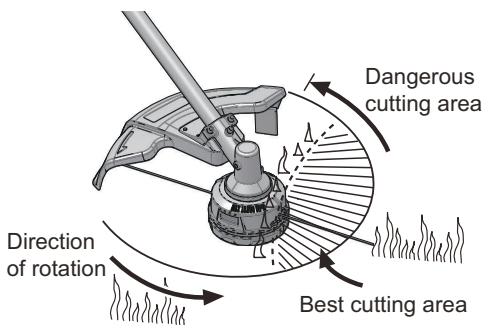

10 MAINTENANCE

i IMPORTANT

Read and understand the safety regulations and the maintenance instructions before you clean, repair or do the maintenance work on the machine.

i IMPORTANT

Make sure that all nuts, bolts and screws are tight. Examine regularly that you install the handles tightly.

i IMPORTANT

Use only the replacement parts and accessories of the initial manufacturer.

10.1 GENERAL INFORMATION

i IMPORTANT

Only your dealer or approved service center can perform maintenance that is not given in this manual.

Before the maintenance operations:

- Stop the machine.
- Remove the battery pack.
- Cool the motor.
- Store the machine in cool and dry place.
- Use correct clothing, protective gloves and safety glasses.

10.2 CLEAN THE MACHINE

- Clean the machine after use with a moist cloth dipped in neutral detergent.
- Do not use aggressive detergents or solvents to clean the plastic parts or handles.
- Keep the trimmer head free of grass, leaves, or excessive grease.
- Keep the air vents clean and free of debris to avoid overheating and damage to the motor or the battery.
- Do not spray water onto the motor and electrical components.

10.3 REPLACE EXCESS LINE

1. Push the tabs (a) on the sides of the trimmer head at the same time.

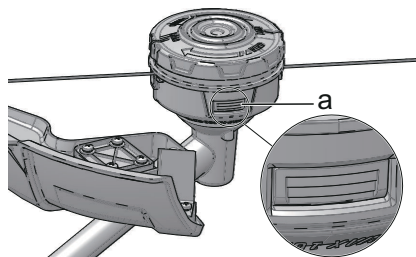

2. Pull and remove the spool cover (b).
3. Remove any remaining line.

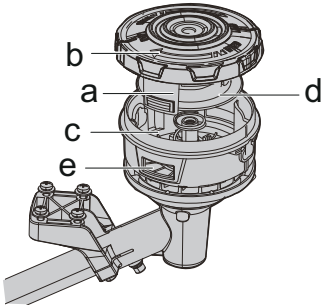

4. Clean dirt and debris from all parts. Replace spool (d) if it is worn or damaged.
5. Align the spool tabs (a) with the tab openings in the base of the spool (e).

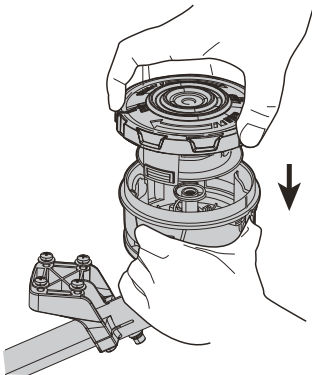

6. Push the spool cover until it clicks into position.

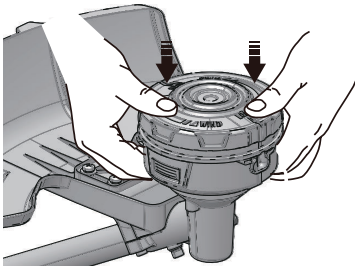

2. Line up the slots on the spool cover with the slots (a) on the trimmer head.

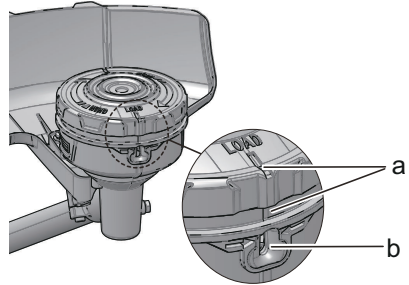

3. Insert the line into the mounting hole, which is located inside the eyelet (b). Push the cutting line until it exits the opposite hole.

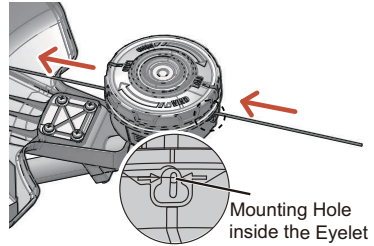

4. Pull the cutting line through until there is an equal quantity of cutting line on each side.

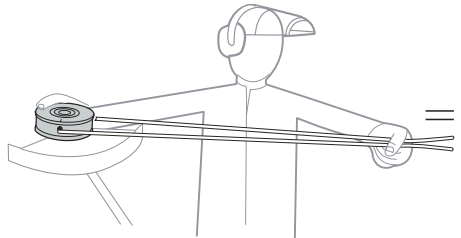

5. Rotate the spool cover clock-wise in the arrow direction to wind the cutting line into the trimmer head. Keep approximately 5 in of cutting line above out of each side of the trimmer head.

10.4 INSTALL THE CUTTING LINE

i NOTE

Do not put more than 15 feet of cutting line in at a time.

1. Remove the remaining cutting line on the spool.

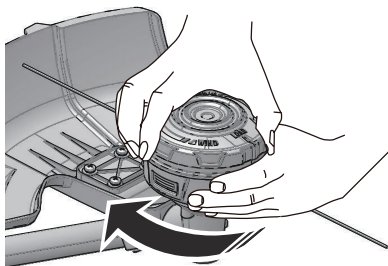

10.5 REPLACE THE SPOOL

i NOTE

If any parts of the spool retainer assembly are damaged or worn, replace the damaged part and reassemble them as following showing

1. Disassemble the trimmer head . Pull and remove the spool cover (b).

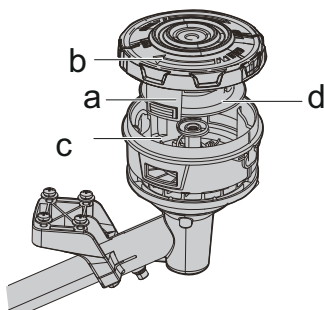

2. Clean dirt and debris from all parts. Replace spool (d) if it is worn or damaged.
3. Loosen the screws (e). Remove the spool (d), slot cover (f), location housing (g) from the spool assembly.
4. Replace with a new spool.
5. Insert the location housing and slot cover onto the spool cover (b), and then put the spool onto the slot cover to the desired position.
6. Tighten with the screws.

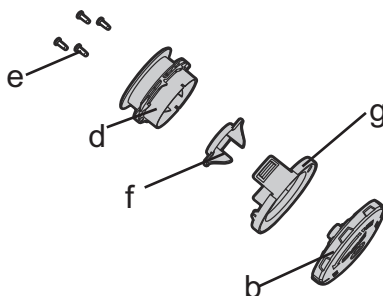

10.6 REMOVE THE TRIMMER HEAD

1. Put the metal rod (a) in the specified angle transmission hole (b) to fix the trimmer head.

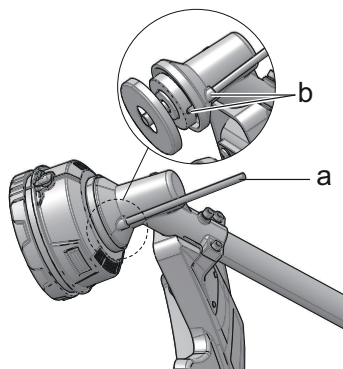

2. Turn the trimmer head clockwise to loosen it. Do not remove the spacer from the shaft.

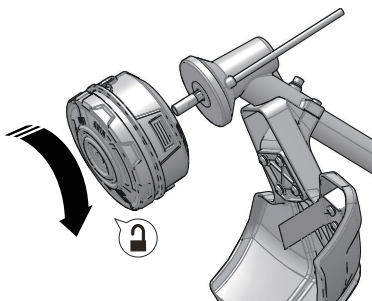

10.7 ASSEMBLE THE TRIMMER HEAD

1. Put the metal rod in the specified angle transmission hole to fix the trimmer head.
2. Assemble the new trimmer head.
3. Turn the trimmer head counterclockwise to tighten it.

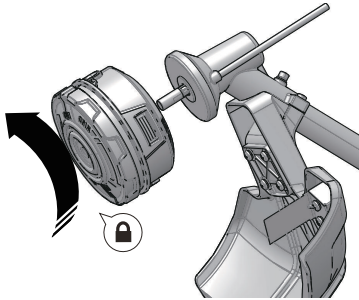

4. Remove the metal rod.

i IMPORTANT

You must install the cut-off blade when you use the trimmer head.

11 TRANSPORTATION AND STORAGE

⚠ WARNING

Remove the battery pack from the machine before transportation and storage.

11.1 MOVE THE MACHINE

When you move the machine, you must:

- Stop the machine.
- Remove the battery pack.

11.2 STORE THE MACHINE

- Remove the battery pack from the machine.
- Make sure that children cannot come near the machine.
- Keep the machine away from corrosive agents such as garden chemicals and de-icing salts.
- Secure the machine during transportation to prevent damage or injury. Clean and examine the machine for any damage.

12 TECHNICAL DATA

Type	Cordless, battery powered
Motor	60V Brushless
No load speed	6300/4700 RPM
Cutting line diameter	0.095" / 0.080" (2.4 mm / 2.0 mm)
Cutting path diameter	14 in. /16 in. (35.6 cm / 40.6 cm)
Feed Type	Bump Feed

Weight (without battery pack)	9.15lbs (4.15kg)
Battery model	LB602, LB6025, LB603, LB604, LB605, LB606 and other BAC series
Charger model	CAC801, CH60DP01, 60DPC10A, CH60R00 and other CAC series

The recommended ambient temperature range:

Item	Temperature
String trimmer storage temperature range	32°F (0°C) - 113°F (45°C)
String trimmer operation temperature range	32°F (0°C) - 113°F (45°C)
Battery charging temperature range	39°F (4°C) - 104°F (40°C)
Charger operation temperature range	39°F (4°C) - 104°F (40°C)
Battery storage temperature range	32°F (0°C) - 113°F (45°C)
Battery discharging temperature range	32°F (0°C) - 113°F (45°C)

13 TROUBLESHOOTING

Problem	Possible Cause	Solution
The machine does not start when you push the trigger.	No electrical contact between the machine and the battery pack.	1. Remove battery pack. 2. Check contact and install the battery pack again.
	The battery pack is depleted.	Charge the battery pack.
	The lock-out button and trigger are not pushed at the same time.	1. Pull the lock-out button and hold it. 2. Pull the trigger to start the machine.

Problem	Possible Cause	Solution
The machine stops when you cut.	The guard is not attached to the machine.	Remove the battery pack and attach the guard to the machine.
	Heavy cutting line is used.	Use only with the nylon cutting line of 0.095" / 0.080" (2.4 mm / 2.0 mm) diameter.
	The grass winds around the motor shaft or the trimmer head.	1. Stop the machine. 2. Remove the battery pack. 3. Remove the grass from the motor shaft and trimmer head.
	The motor is overloaded.	1. Remove the trimmer head from the grass. 2. The motor will recover to work as soon as the load is removed. 3. When you cut, move the trimmer head in and out of the grass to be cut and remove no more than 8" in pass.
	The battery pack or machine is too hot.	1. Cool the battery pack until its function returns to normal. 2. Cool the machine for approximately 10 minutes.
The line does not advance.	The battery pack is disconnected from the tool.	Install the battery pack again.
	The battery pack is depleted.	Charge the battery pack.
	Lines are welded to themselves.	Lubricate with silicone spray.
	Not enough line on spool.	Install more line.
The line does not advance.	Lines are worn too short.	Advance the cutting line.
	Lines are tangled on spool.	1. Remove the lines from the spool. 2. Wind the lines.

Problem	Possible Cause	Solution
The line keeps breaking.	The machine is used incorrectly.	1. Cut with the tip of the line, avoid stones, walls and other hard objects. 2. Advance the cutting line regularly to keep full cutting width.
The grass winds around the trimmer head and motor housing.	Cut tall grass at ground level.	1. Cut tall grass from the top down. 2. Remove no more than 8" in each pass to prevent wrapping.
The line does not cut well.	The cut-off blade becomes dull.	Sharpen the cut-off blade with a file or replace it.
Vibration increases obviously.	The line is worn down at one side and not advanced in time.	Make sure that the line on both sides is normal. Advance the line.

14 LIMITED WARRANTY



Greenworks hereby warrants this product, to the original purchaser with proof of purchase, for a period of four (4) years against defects in materials, parts or workmanship. Greenworks, at its own discretion will repair or replace any and all parts found to be defective, through normal use, free of charge to the customer. This warranty is valid only for units which have been used for personal use that have not been hired or rented for industrial/commercial use, and that have been maintained in accordance with the instructions in the owners' manual supplied with the product from new.

ITEMS NOT COVERED BY WARRANTY:

- Any part that has become inoperative due to misuse, commercial use, abuse, neglect, accident, improper maintenance, or alteration; or
- The unit, if it has not been operated and/or maintained in accordance with the owner's manual; or
- Normal wear, except as noted below;
- Routine maintenance items such as lubricants, blade sharpening;

5. Normal deterioration of the exterior finish due to use or exposure.

HELPLINE:

Warranty service is available by calling our toll-free helpline, at 1-855-345-3934.

TRANSPORTATION CHARGES:

Transportation charges for the movement of any power equipment unit or attachment are the responsibility of the purchaser. It is the purchaser's responsibility to pay transportation charges for any part submitted for replacement under this warranty unless such return is requested in writing by Greenworks.

USA address:

Greenworks Tools

P.O. Box 1238

Mooresville, NC 28115

15 REPLACEMENT PARTS

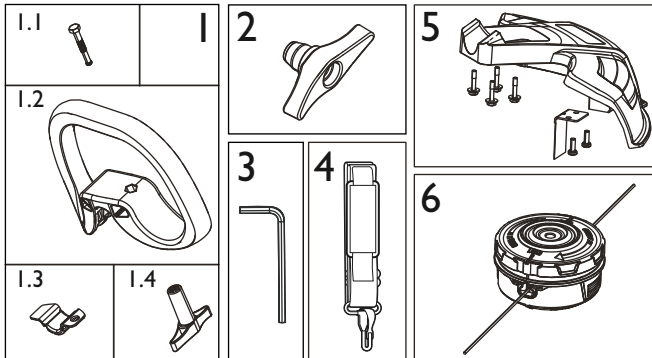

No.	Part No.	Qty	Description	No.	Part No.	Qty	Description
1	R0201836-00	1	Auxiliary handle assembly	2	R0201784-00	1	Coupler knob
1.1	R0201826-00	1	Bolt	3	R0201770-00	1	Allen key
1.2	R0201827-00	1	Auxiliary handle	4	RB37902144	1	Shoulder strap
1.3	R0201828-00	1	Lower clamp	5	R0201835-00	1	Guard assembly
1.4	R0201833-00	1	Knob	6	R0201834-00	1	Trimmer head assembly