

Anatomy of a Tragedy: Fukushima Dai-Ichi March 2011

**Dave Lochbaum
April 2011**

The eyeball icon  on a slide indicates that details are available on the following slides.

Fukushima Dai-ichi: Status before the Earthquake

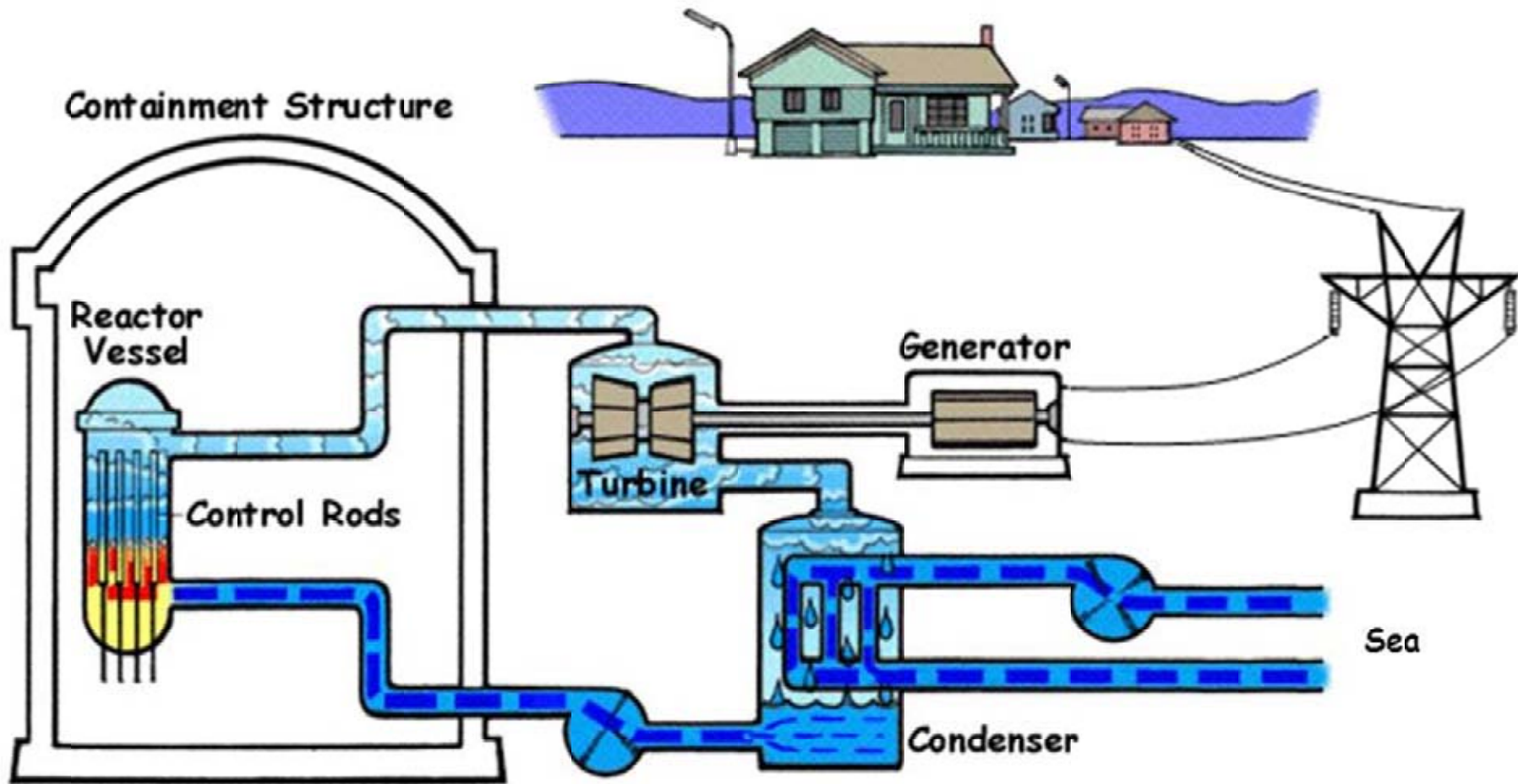

Units 1, 2, and 3 operate at full power. Steam produced by water boiling in the reactor vessel flows through the turbine generating electricity and gets turned back into water within the condenser. The water is returned to the reactor vessel. Warmed sea water returns to the Pacific Ocean.

Fukushima Dai-ichi: Status before the Earthquake

During normal operation, steam leaves the reactor vessel enters via nozzles connected to the main steam system piping.

During normal operation, makeup water to the reactor vessel enters via nozzles connected to the feedwater system piping.

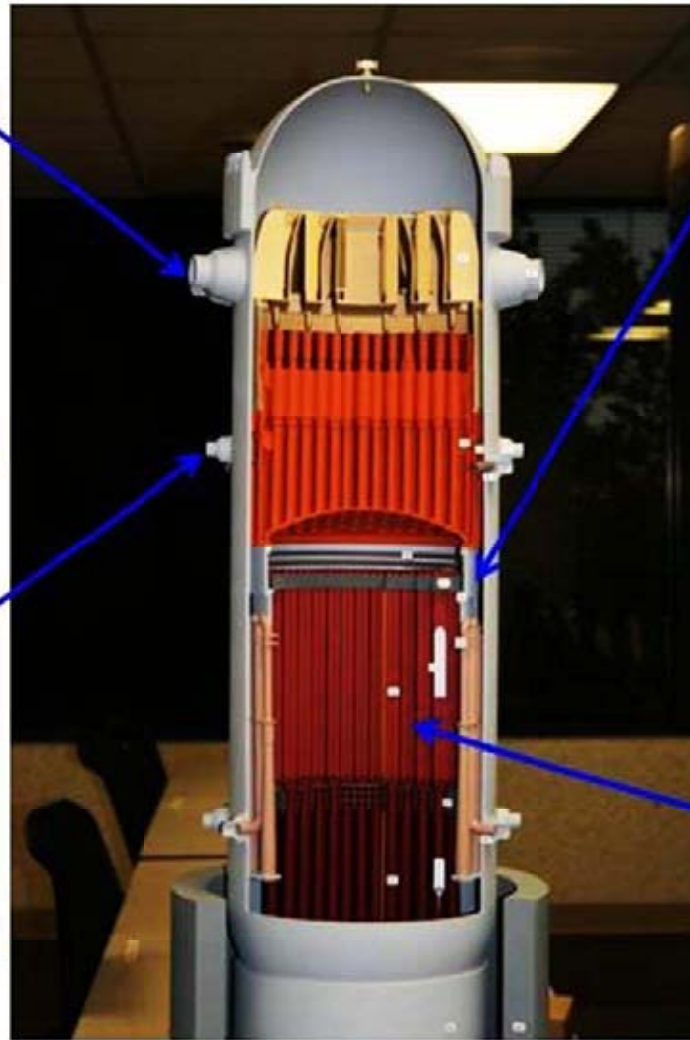

The core shroud is an open metal can surrounding the reactor core. Slightly smaller in diameter than the reactor vessel, the shroud forces water down through the space between the vessel wall and shroud wall and then up through the reactor core.

The reactor core sits in the lower half of the reactor vessel.

Units 4, 5, and 6 were shut down for scheduled refueling and maintenance outages. All of the fuel from the Unit 4 reactor had been offloaded into its spent fuel pool in late 2010 to allow the core shroud to be replaced.

Unit 1, 2, and 3 Operating Reactors

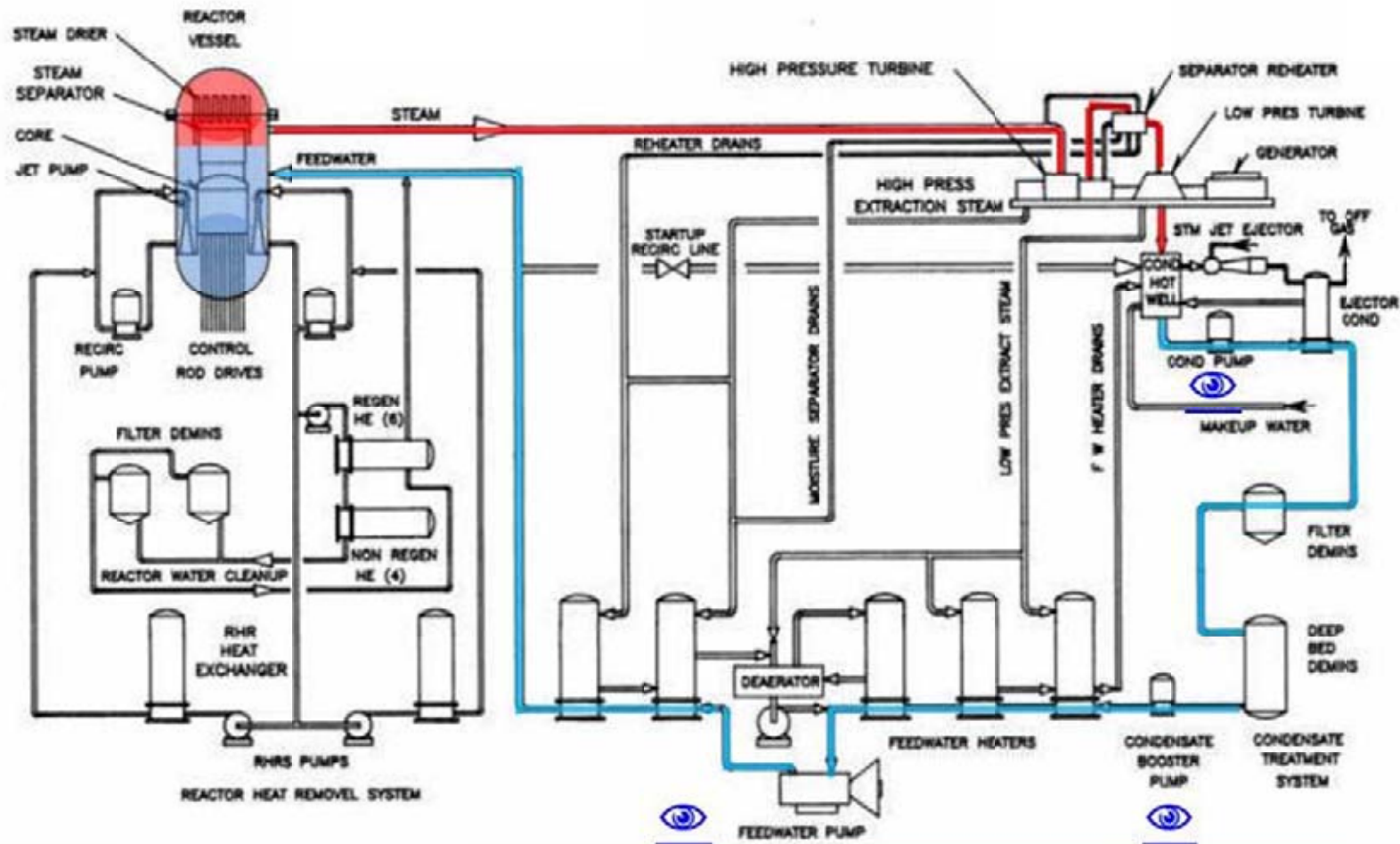

Heat from the reactor core boils water in the reactor vessel. Steam flows through the turbine to the condenser. Sea water cools the steam back into water. The condensate pumps, condensate booster pumps, and feedwater pumps return filtered and pre-warmed water to the reactor vessel.

Detail

Condensate Pumps

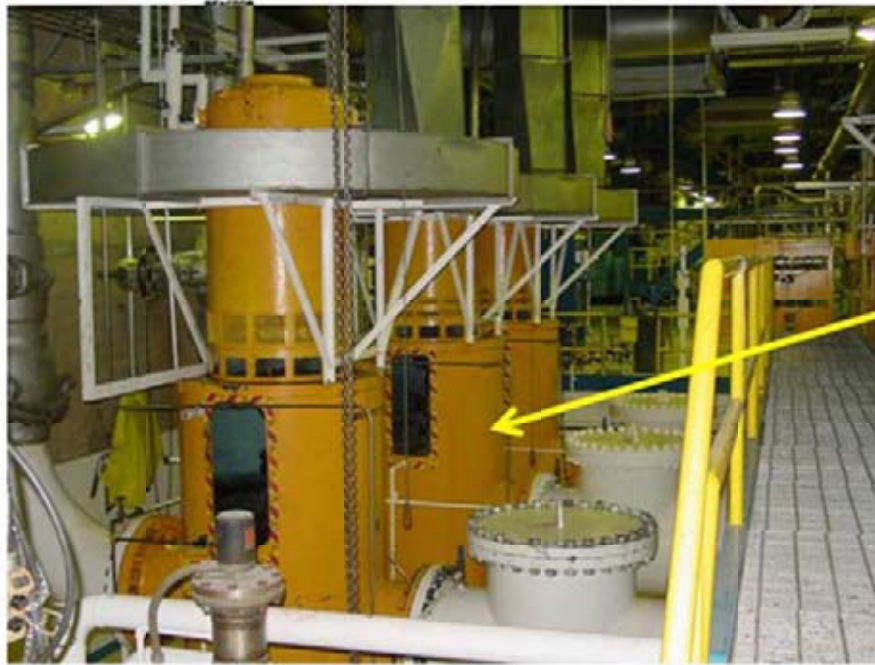

Condensate pumps are large electric motor-driven pumps. Three condensate pumps are shown on the left of this picture. Their motors sit atop them with donut-shaped cooling units around them.

Detail

Condensate Booster Pumps

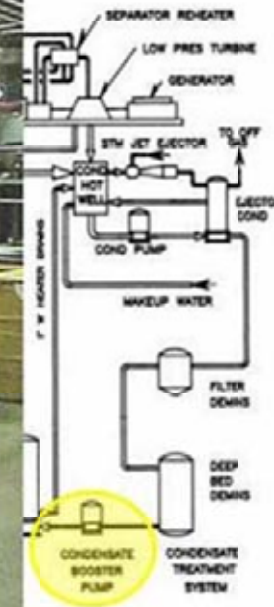

Condensate booster pumps are also large electric motor-driven pumps. A condensate pump is shown on the left of this picture. The motor is behind the pump with cooling unit ducting above it.

Detail

Feedwater Pumps

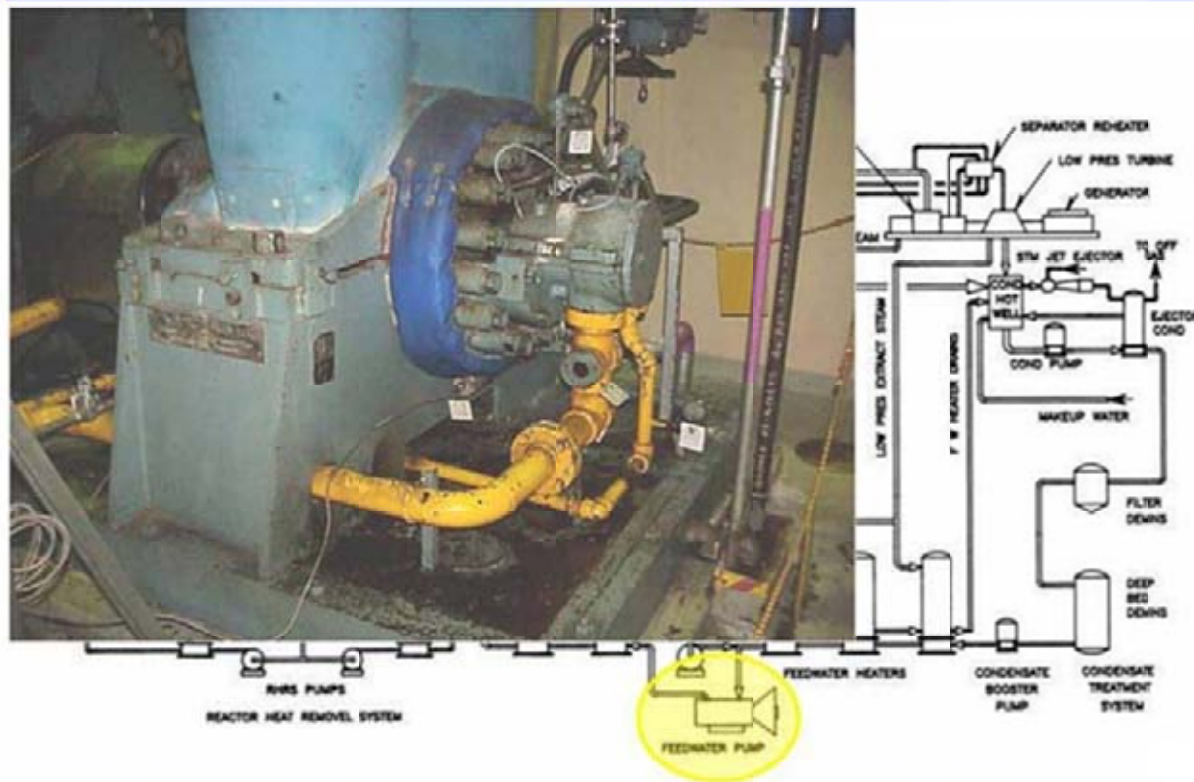

Feedwater pumps are large steam-driven pumps. A feedwater pump is shown in this picture with its turbine in the background.

Unit 1-6 Spent Fuel Pools

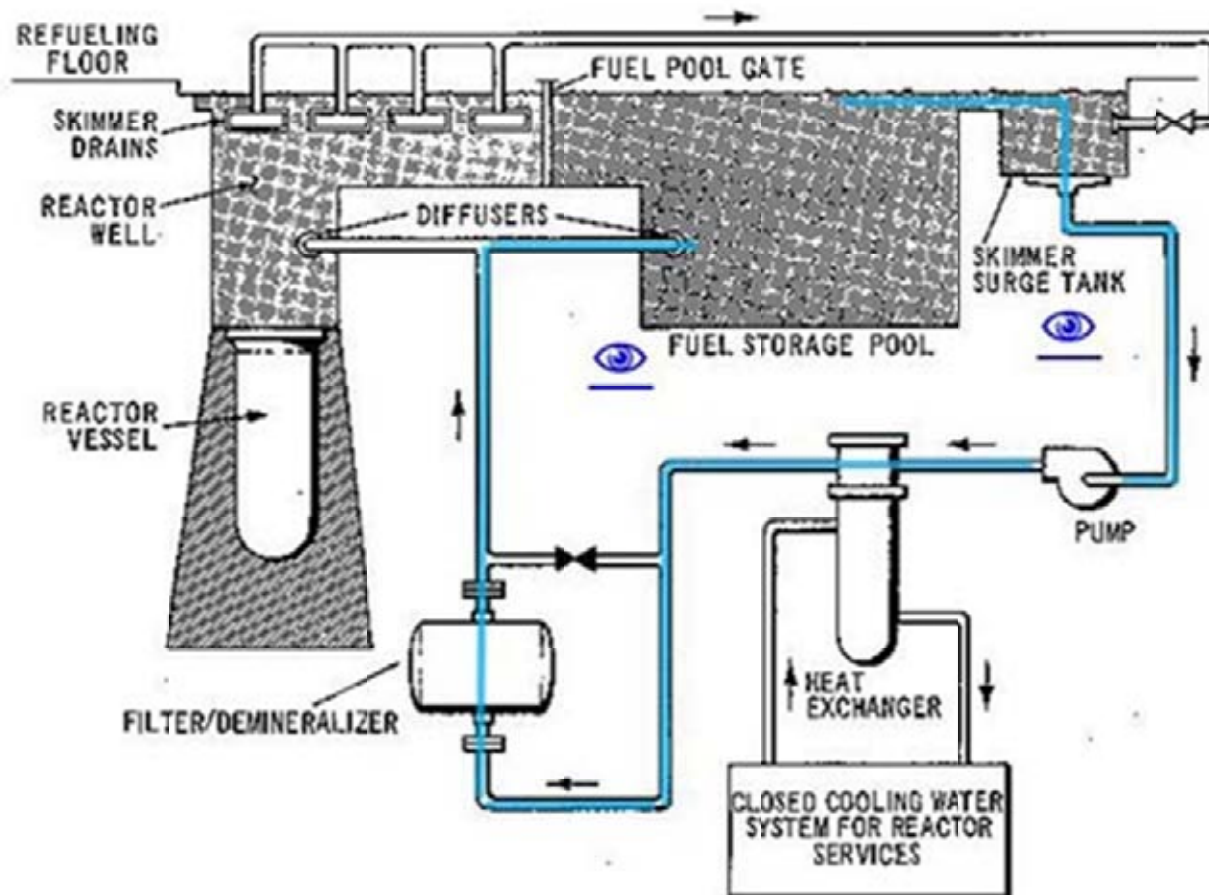

Each unit has an individual spent fuel pool. With fuel pool gates installed, the spent fuel pool is physically isolated from the reactor well and reactor vessel. The spent fuel pool is cooled by water overflowing into a skimmer surge tank. Pumps route this water through a heat exchanger to cool it and a filter/demineralizer unit to purify it before returning it to the pool.

Detail

Spent Fuel Pool

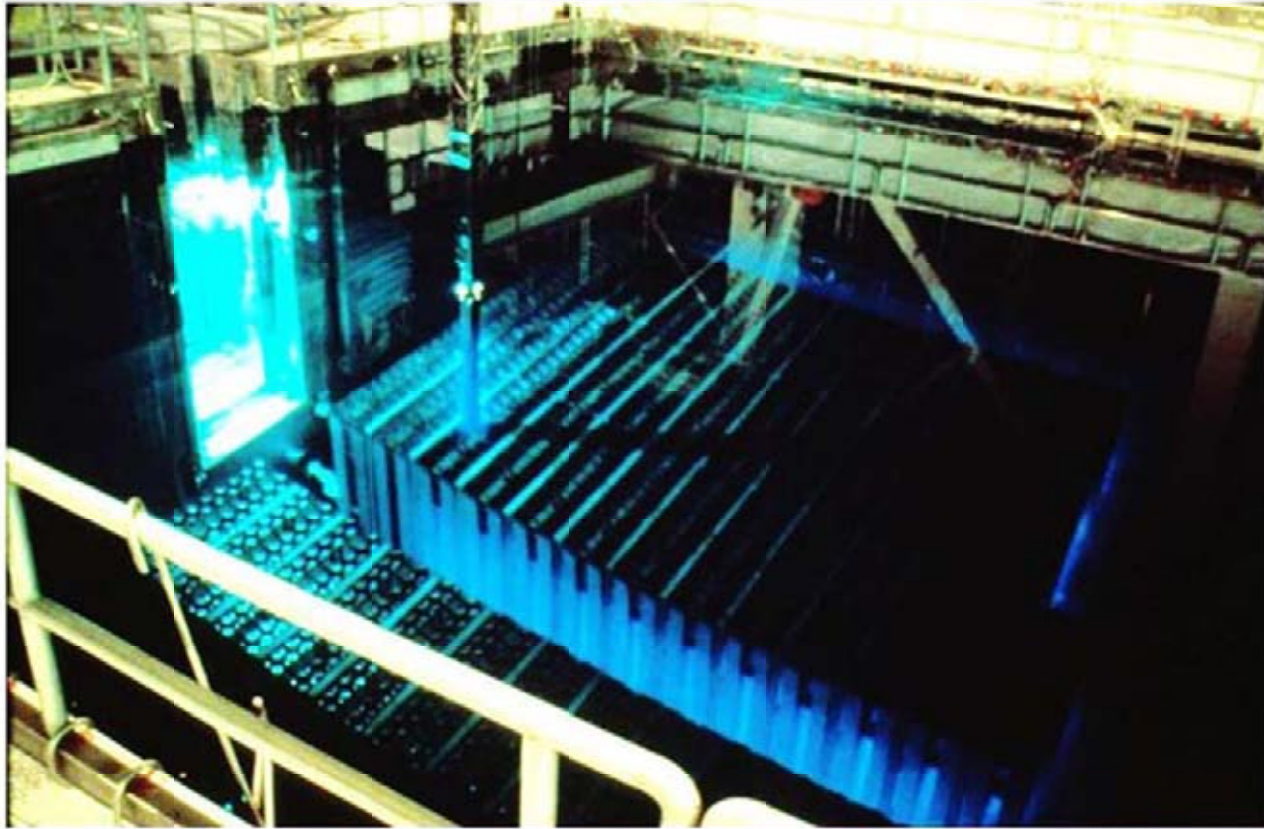

A spent fuel pool with the fuel pool gate to the reactor well open. An irradiated fuel assembly, glowing blue due to Cerenkov radiation, is being transported using the fuel handling platform.

Detail

Skimmer Surge Tank



Water from the overflow ports from the spent fuel pool enters the skimmer surge tank. If the spent fuel pool water level drops below the overflow ports, water stops entering the skimmer surge tank and cooling is lost.

Unit 1, 2, and 3 Operating Reactors

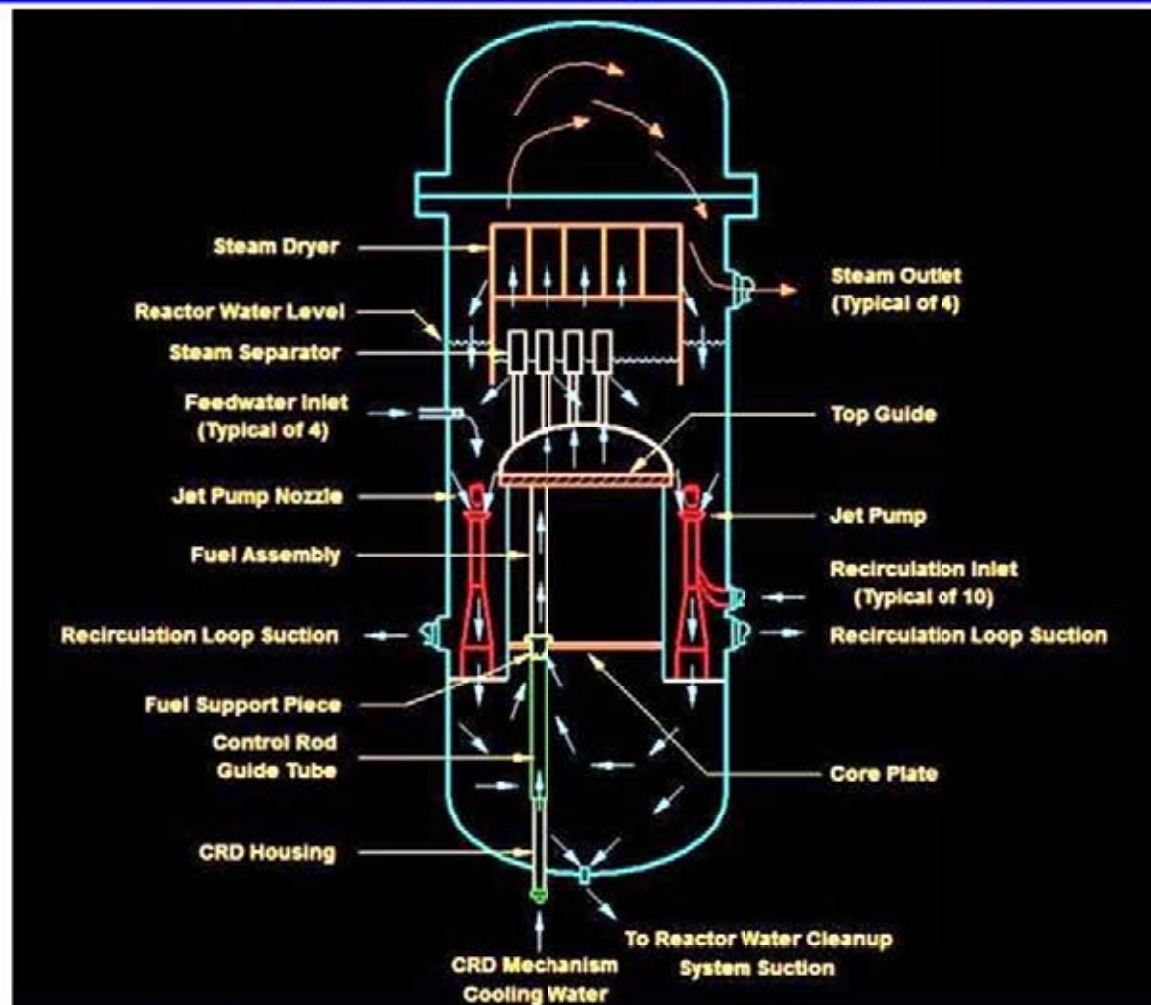

The feedwater pumps inject makeup water to the reactor vessel. This water mixes with water draining from the steam separator and steam dryer and enters the jet pumps nozzles to flow to the bottom of the reactor vessel. It turns upward to flow through the reactor core. A steam/water mix passes through the steam separator and steam dryer. Steam leaves for the turbine.

Unit 1, 2, and 3 Operating Reactors

Building Section

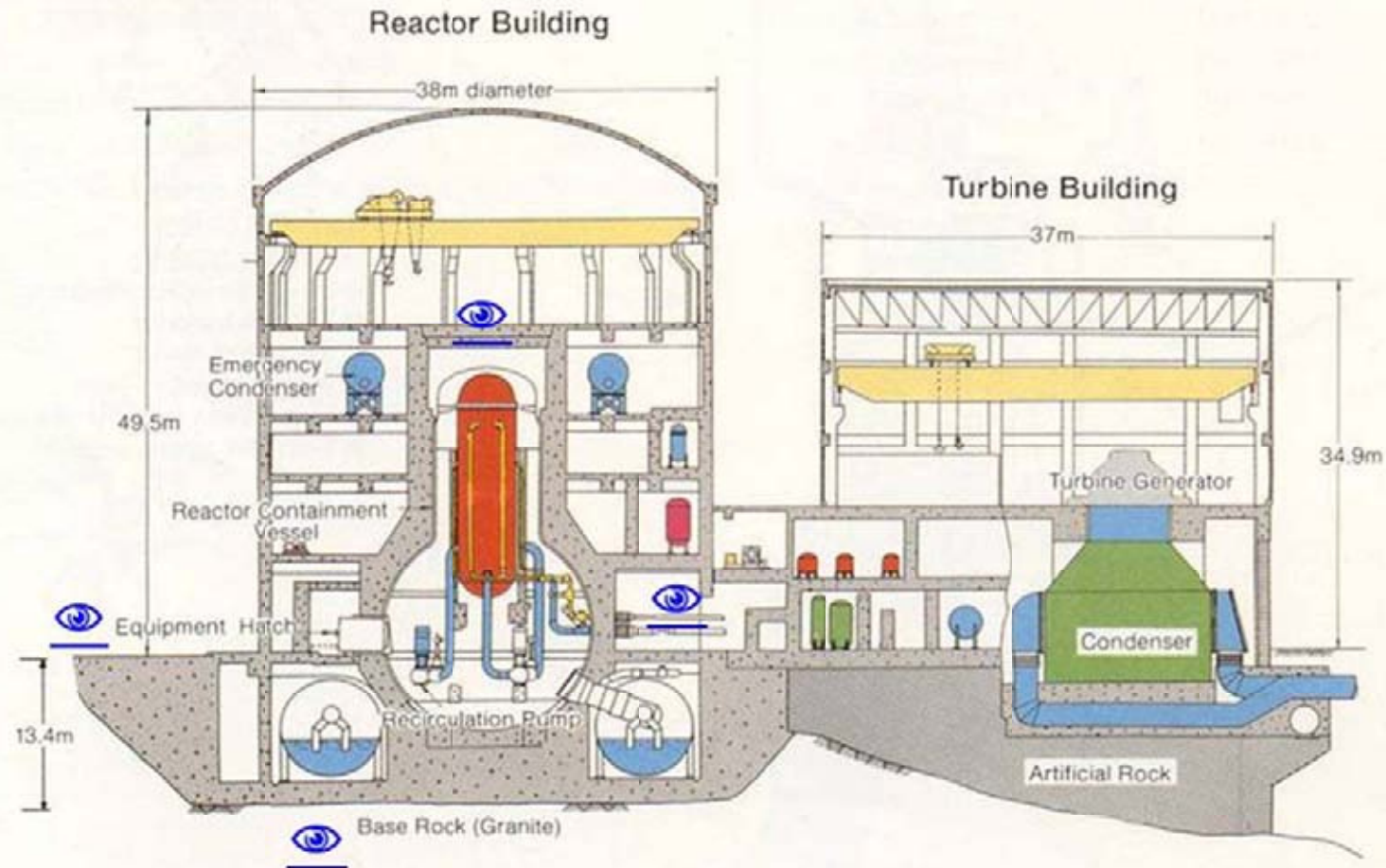

The Mark I primary containment features a drywell (the inverted lightbulb) and a torus (the donut) connected by eight vent pipes. The reactor building surrounds the primary containment. Steam and feedwater piping passes through the containment walls and reactor building to the turbine building.

Detail

Primary Containment

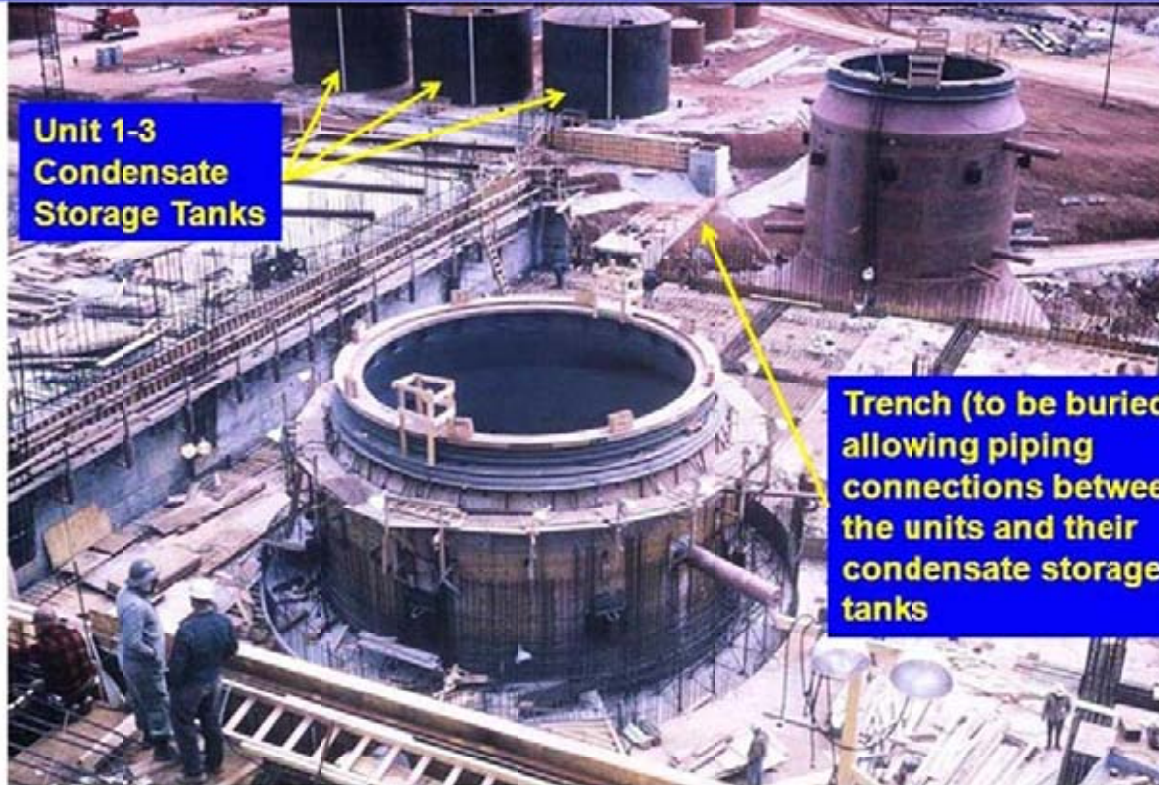

Unit 1-3
Condensate
Storage Tanks

Trench (to be buried)
allowing piping
connections between
the units and their
condensate storage
tanks

The drywells for Unit 2 (foreground) and Unit 3 (background) at the Browns Ferry nuclear plant in Alabama. The Unit 2 reactor building is being constructed around primary containment.

Detail

Primary Containment Equipment Hatch



The equipment hatch through the primary containment wall as viewed from the reactor building. A rack containing various instruments appears on the left. Fire sprinkler piping painted red runs overhead.

Detail

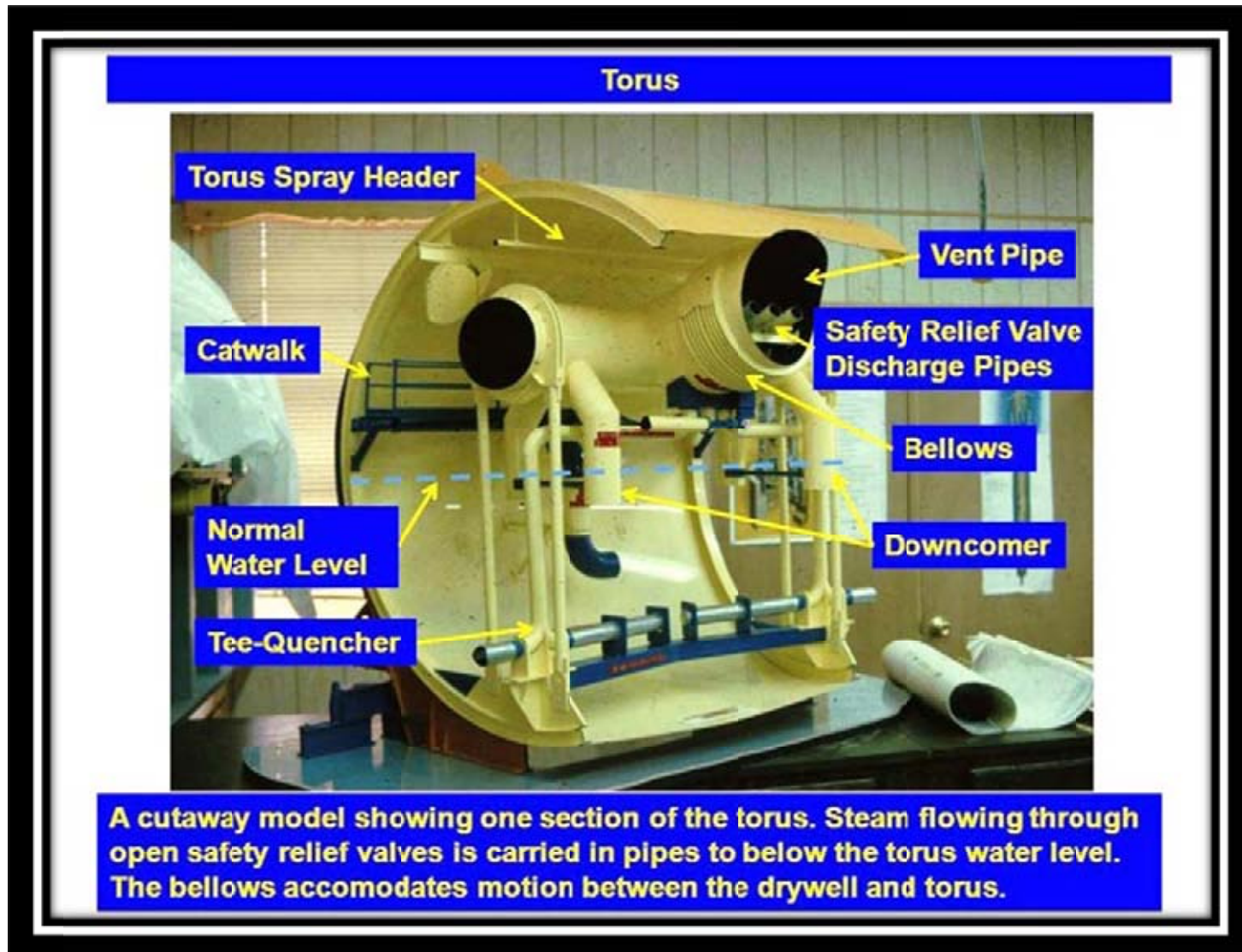

Detail

Steam Tunnel



Two feedwater pipes (above) and four steam pipes (below) pass through the steam tunnel in the reactor building connecting the containment with the turbine building. Pipe supports, noted in yellow circles, protect the piping from earthquake motions.

Unit 1, 2, and 3 Operating Reactors

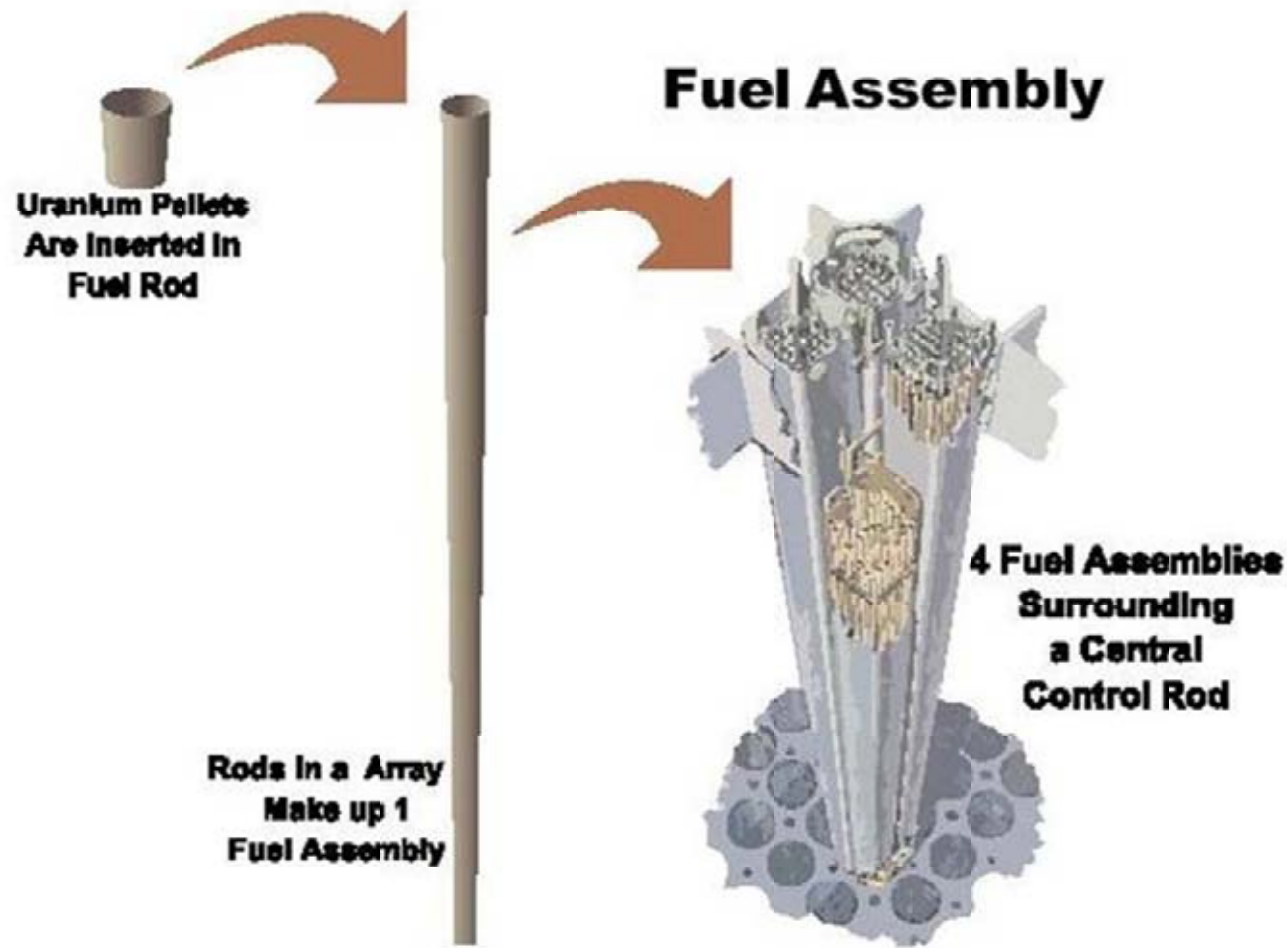

Fuel pellets containing uranium dioxide are stacked within metal fuel rods. Metal fuel rods are placed within fuel assemblies. Workers move fuel assemblies into reactor core locations.

Unit 1, 2, and 3 Operating Reactors

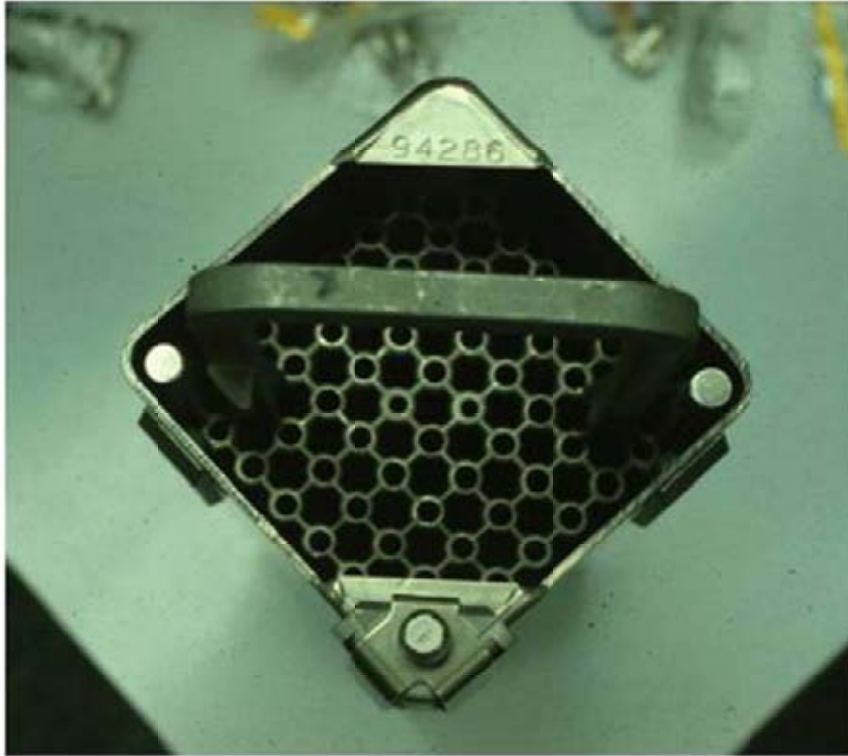

ABOVE: Looking down at a fuel assembly. The inverted U-shaped handle is used to pick up and move the assembly. The tops of fuel rods stick up into the holes of the spacer grid for proper alignment.

LEFT: A simulated fuel rod is cut open to show fuel pellets and the spring keeping them in place during handling.



Unit 1, 2, and 3 Operating Reactors

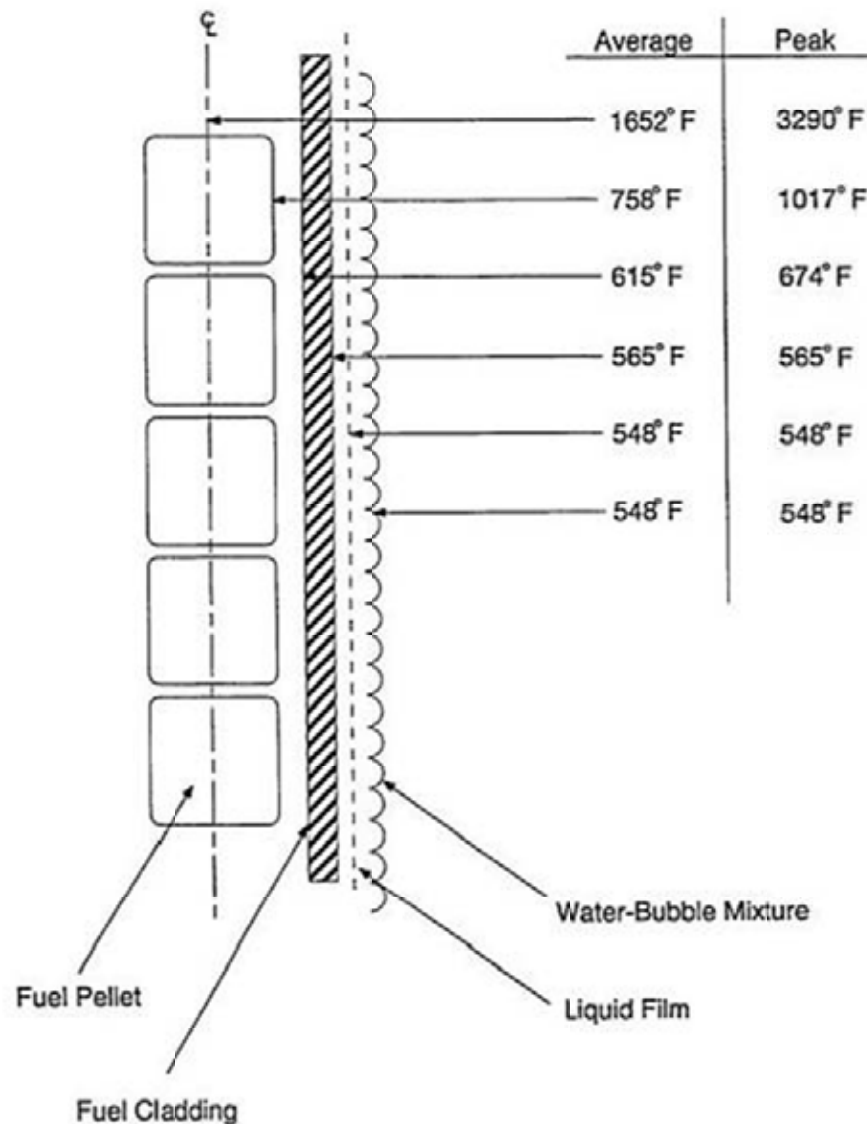

Fuel Temperature Cross Section

During operation, the temperature at the center of the average fuel pellet is 1,652°F with a peak temperature of 3,290°F. The temperature drops as heat passes through the pellet, the gap between the pellet the cladding, the fuel rod cladding, and a water film layer on the outside surface of the cladding.

The water/steam temperature flowing past the fuel rods is 548°F, well above the 212°F temperature that water boils at when not under pressure of nearly 1,000 pounds per square inch as exists inside the reactor vessel.

Unit 1, 2, and 3 Shutdown Reactors

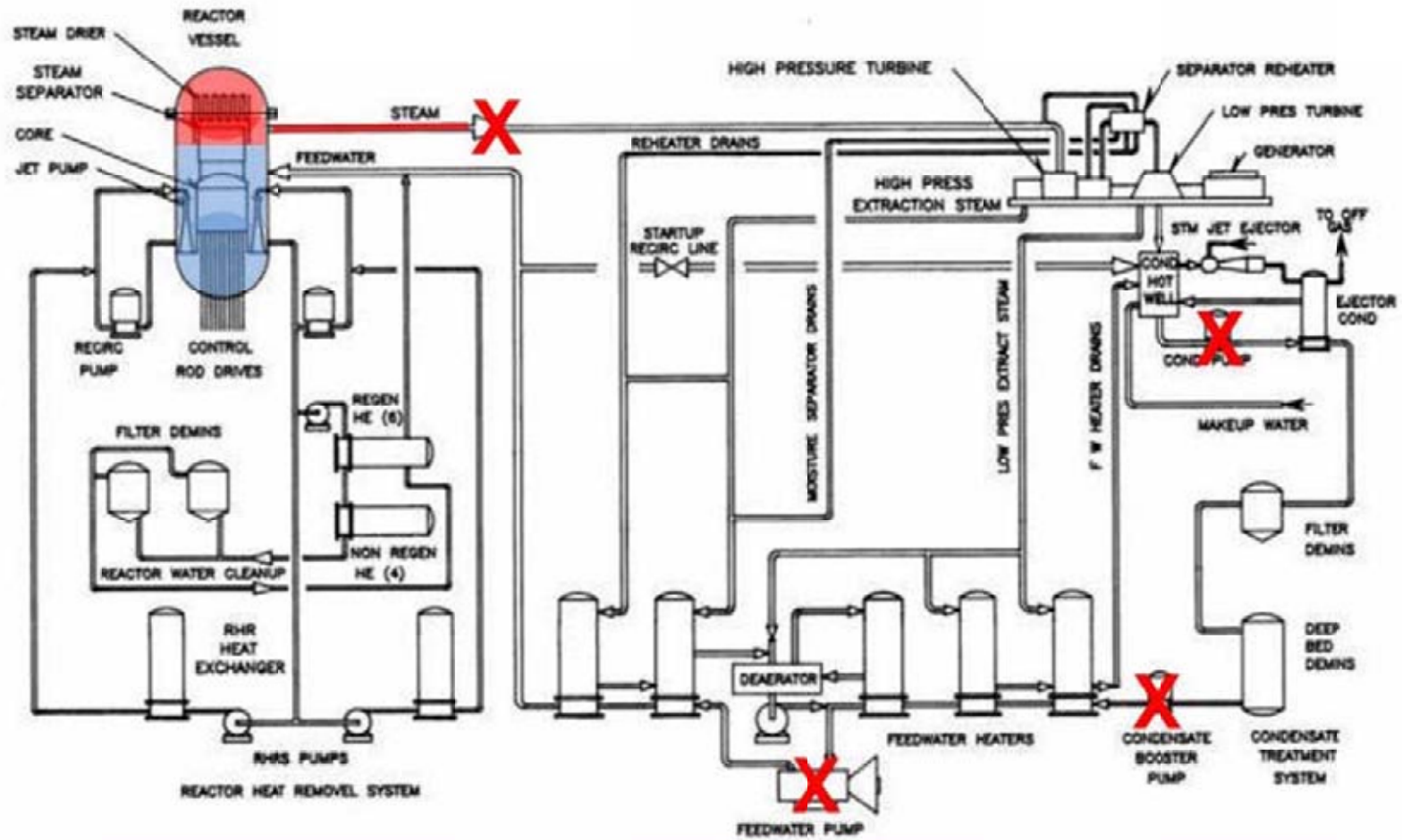

The earthquake is reported to have caused Units 1-3 to automatically shutdown and to disconnect the plant from its electrical grid. Even with emergency diesel generators, the condensate, condensate booster, and feedwater pumps are unavailable due to loss of the normal power supply.

Unit 1, 2, and 3 Shutdown Reactors

Plant Name	BWR Class	Product Line	Containment *Type	MWT	MWE	Power Density KW/L	No. Fuel Bundles	No. Control Rods	IC or RCIC	LPCI or RHR *4	Feed Pump Type	Bypass Capacity	RFC Type	HPCI or HPCS	No. Relief Valves	Press. Control Initial / Backup	*Type Oofgas
Oyster Creek	2	63	Mark I	1930	620	33.6	560	137	IC	-	M	45	MG*5	FWCI	4	EPR/MPR	AMB
Nine Mile Point #1	2	63	Mark I	1850	620	34.0	532	129	IC	-	M&T	45	MG*5	FWCI	6	EPR/MPR	Low Temp
Dresden #2	3	65	Mark I	2527	809	41.08	724	177	IC	LPCI	M	45	MG	HPCI	5	EHC/EHC	AMB
Millstone	3	65	Mark I	2011	690	40.08	580	145	IC	LPCI	MM	100'(3)	MG	FWCI	3	EPR/MPR	Low Temp
Dresden #3	3	66	Mark I	2527	809	41.08	724	177	IC	LPCI	M	45	MG	HPCI	5	EHC/EHC	AMB
Monticello	3	66	Mark I	1670	545	40.6	484	121	RCIC	RHR (A)	M	15	MG	HPCI	4	EPR/MPR	Comp
Quad Cities 1/2	3	66	Mark I	2511	809	40.9	724	177	RCIC	RHR (A)	M	45	MG	HPCI	5	EHC/EHC	AMB
Pilgrim	3	66	Mark I	1938	655	40.5	580	145	RCIC	RHR (A)	M	26	MG	HPCI	4	EPR/MPR	AMB
Brown's Ferry 1/2/3	4	67	Mark I	3233	1065	50.7	764	185	RCIC	RHR (A)	T	26	MG	HPCI	13	EHC/EHC	AMB
Vermont Yankee	4	67	Mark I	1593	514	51.0	368	69	RCIC	RHR (A)	M	100'(3)	MG	HPCI	4	EPR/MPR	AMB
Duane Arnold	4	67	Mark I	1658	538	51.0	368	69	RCIC	RHR (A)	M	26	MG	HPCI	6	EHC/EHC	AMB
Peach Bottom 2/3	4	67	Mark I	3293	1065	50.7	764	195	RCIC	RHR (A)	T	26	MG	HPCI	11	EHC/EHC	Comp
Cooper	4	67	Mark I	2381	778	50.6	548	137	RCIC	RHR (A)	T	26	MG	HPCI	8	Digital (W)	Low Temp
Hatch 1/2	4	67	Mark I	2436	786	51.2	560	137	RCIC	RHR (A)	T	26	MG	HPCI	9	EHC/EHC	AMB
Brunswick #1	4	67	Mark I (C)	2436	821	51.2	560	137	RCIC	RHR (A)	T	100'(3)	MG	HPCI	9	EHC/EHC	AMB
Brunswick #2	4	67	Mark I (C)	2436	821	51.2	560	137	RCIC	RHR (A)	T	26	MG	HPCI	9	EHC/EHC	AMB

Unit 1 is a BWR/3 while Units 2 and 3 are BWR/4s. All BWR/4s feature a reactor core isolation cooling system (RCIC) to cool the reactor when the normal power supply is lost. Some BWR/3s have RCIC while older BWR/3s relied on an isolation condenser (IC) to perform this role.

Unit 2 and 3 Shutdown Reactors

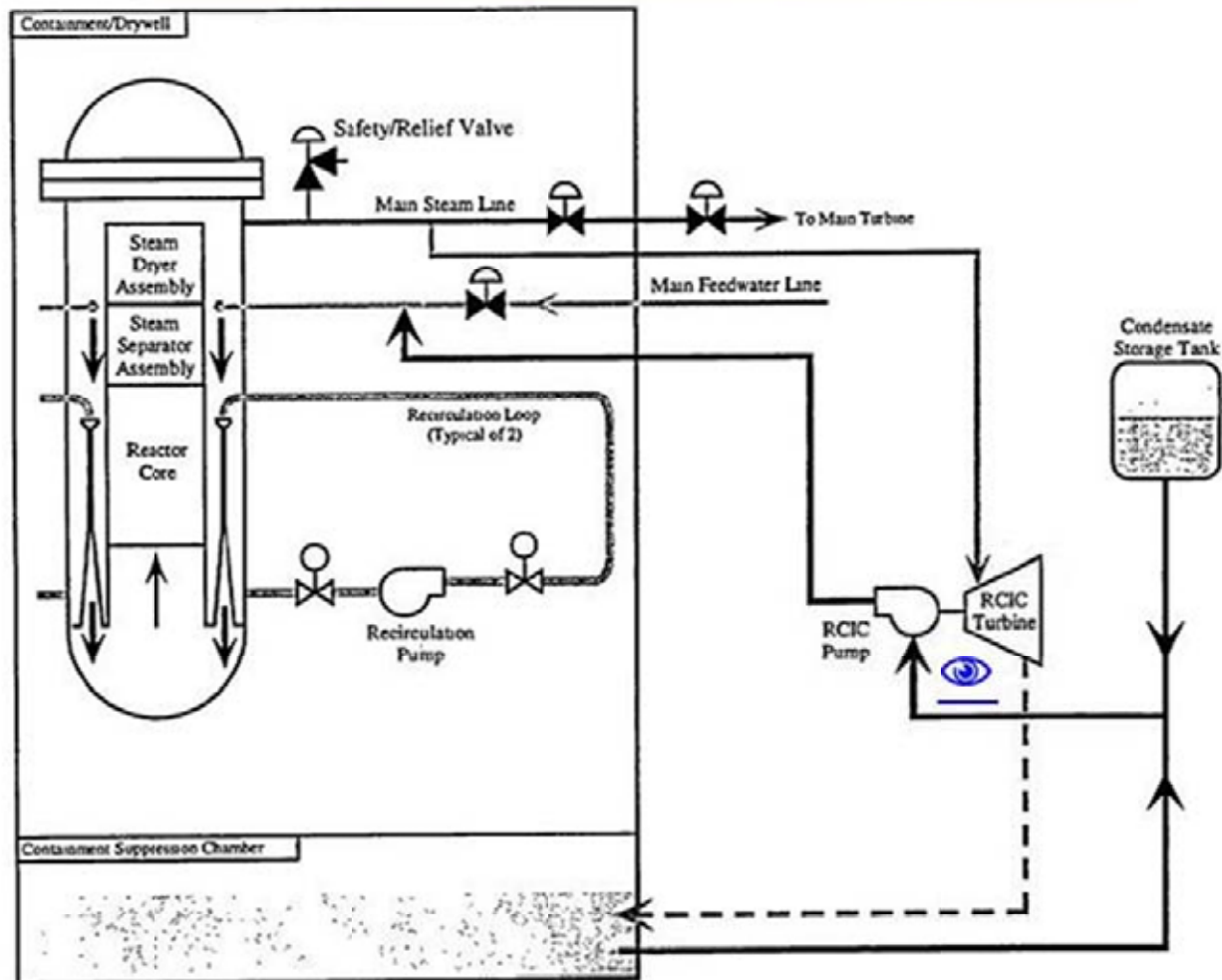

The reactor core isolation cooling (RCIC) system uses steam produced by the reactor core's decay heat to spin a turbine connected to a pump. This pump transfers water from the condensate storage tank (or torus as a backup) to the reactor vessel.

Detail

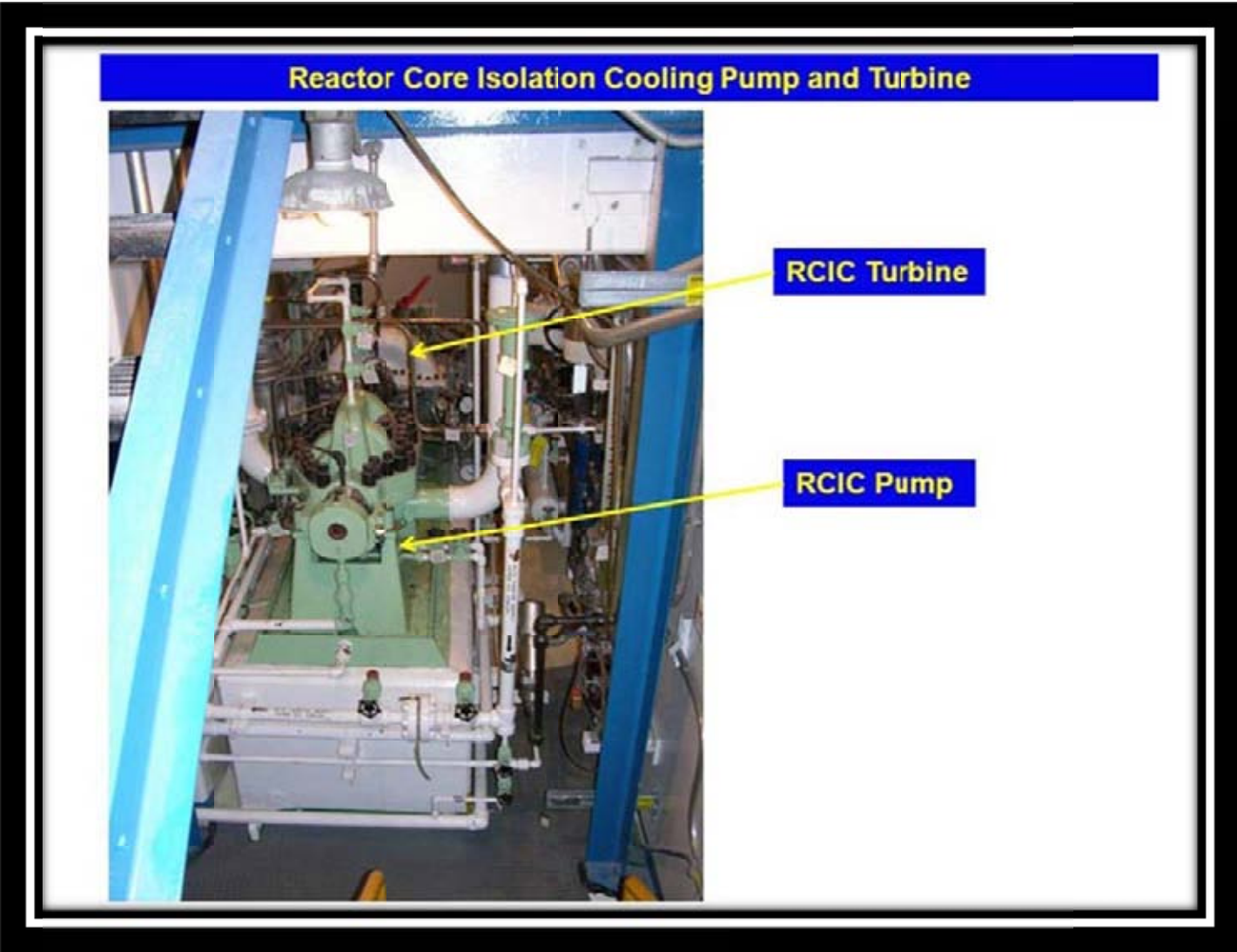

Unit 2 and 3 Shutdown Reactors

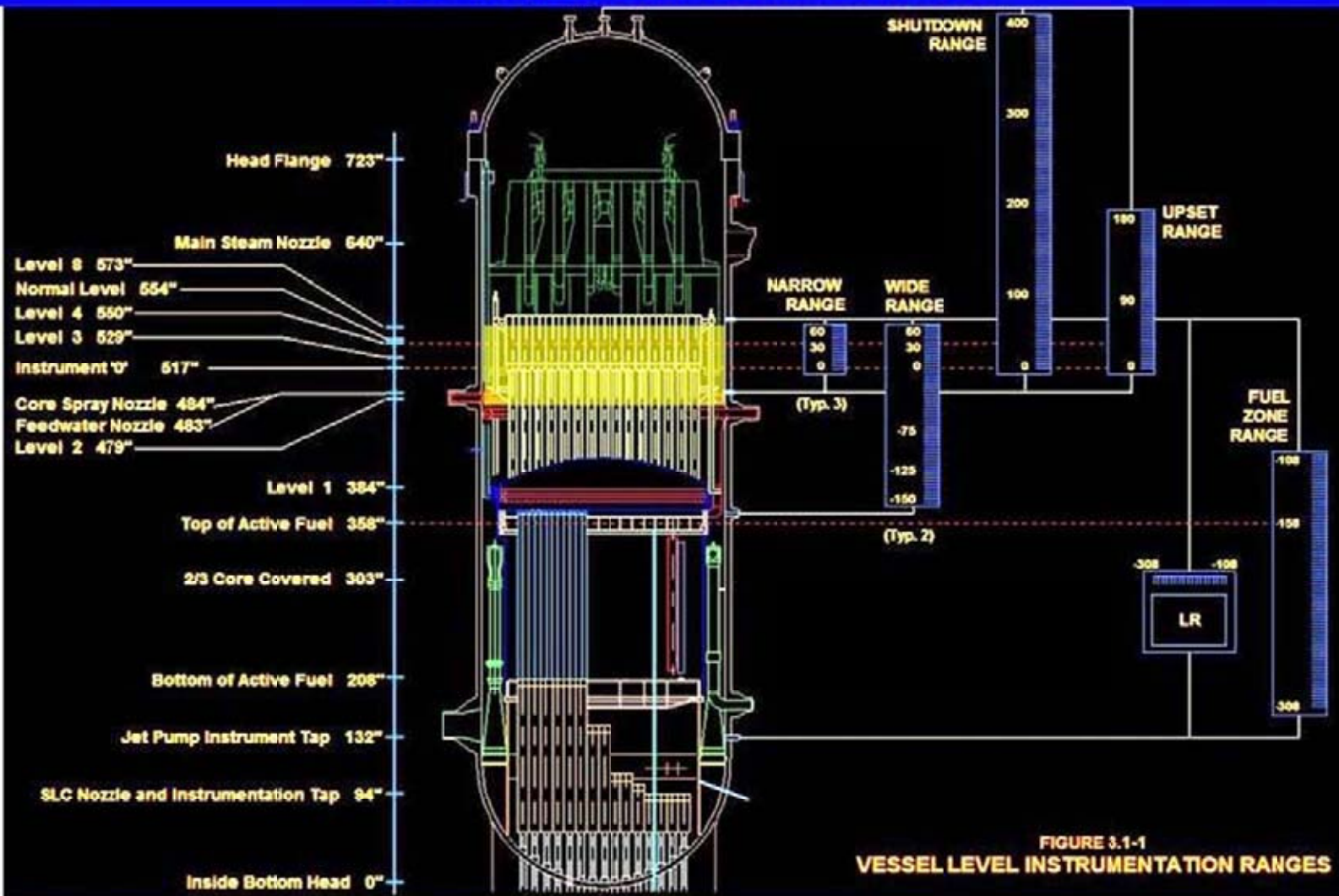

Even without operator action, the RCIC system is designed to maintain the water level between Level 2 and Level 8. If not already running, the RCIC system is automatically started when the water level drops below Level 2. And if not already stopped, the RCIC system automatically stops at Level 8.

Unit 1 Shutdown Reactor

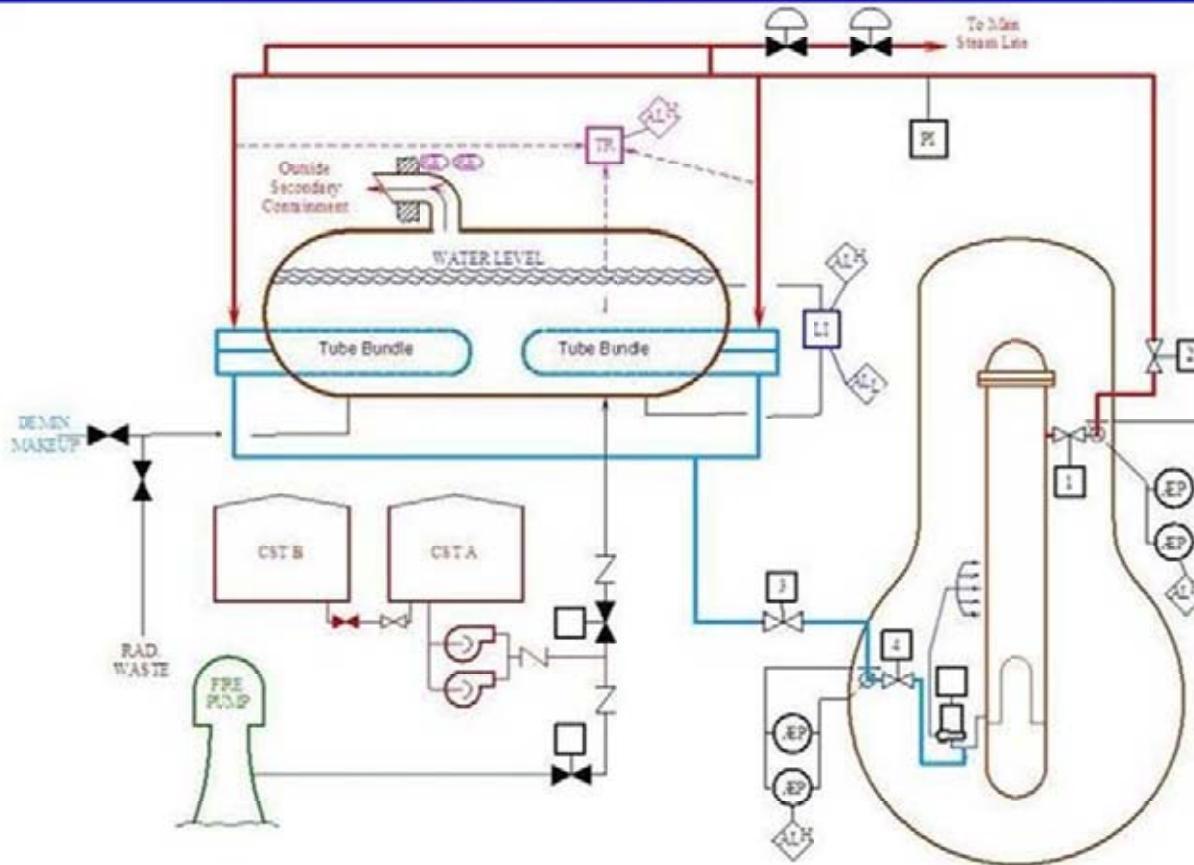

The isolation condenser (IC) is a passive system using no pumps. Instead, steam produced by the reactor core's decay heat is routed through metal tubes within a large tank of water called the isolation condenser. The steam is converted back into water and flows by gravity to the reactor vessel. Unit 1 is a BWR/3. It may have had a RCIC system like Units 2 and 3, or may have had an isolation condenser.

Backup Power



Engine cylinder covers

Upon loss of the normal power supply, emergency diesel generators started and provided electrical power for safety systems needed to cool the reactor cores and ensure containment integrity.

Detail



Loss of Backup Power



The tsunami reportedly disabled the emergency diesel generators. This left the plant with no power except for direct current (dc) electricity provided by a bank of batteries. All the emergency core cooling systems, except RCIC, became useless.

Unit 2 and 3 Shutdown Reactors

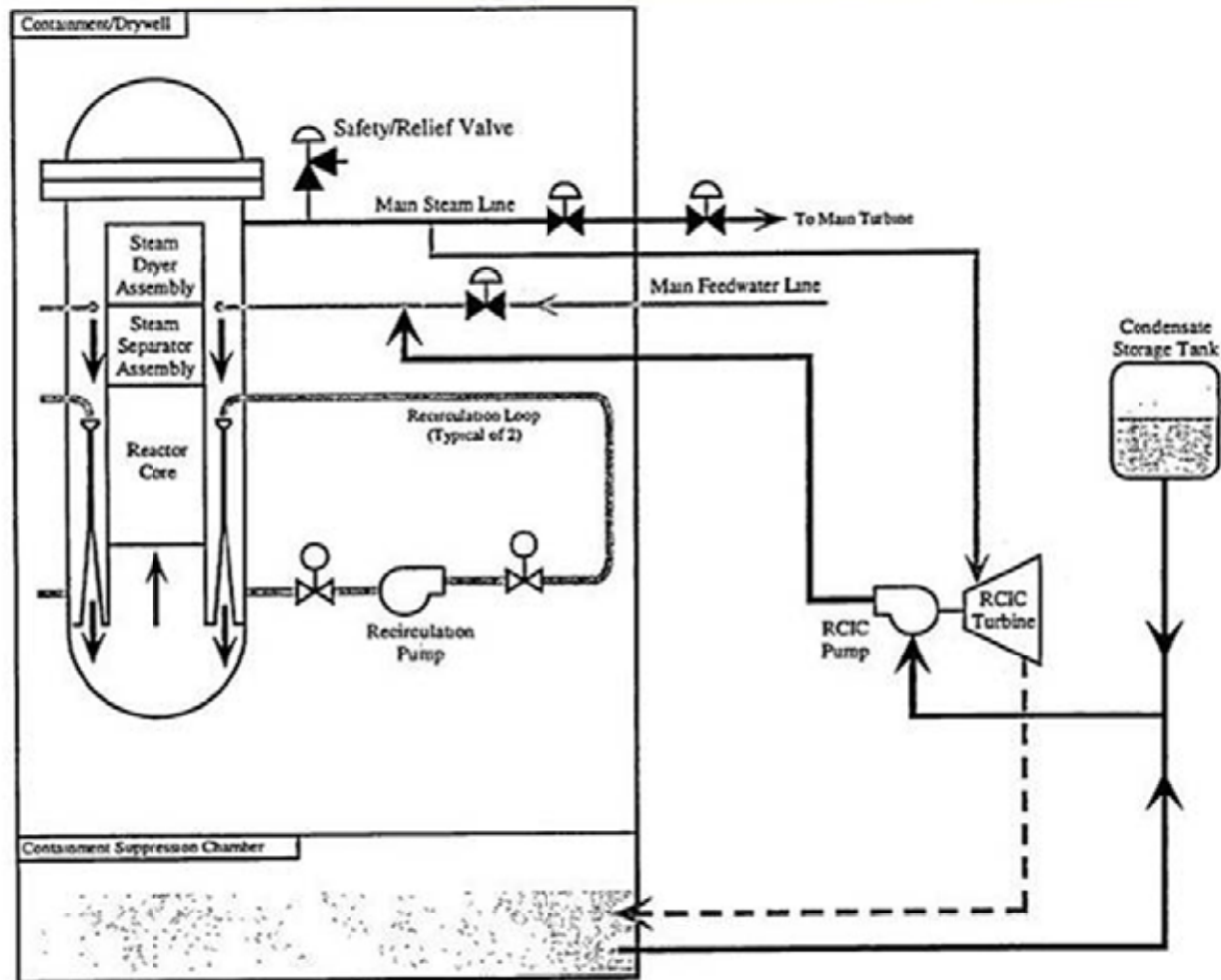

Battery power to steam admission valves and turbine controls would have allowed the reactor core isolation cooling (RCIC) system to continue operating. When the batteries depleted after around 8 hours, this source of makeup cooling water to the reactor vessels would have been lost.

Unit 1 Shutdown Reactor

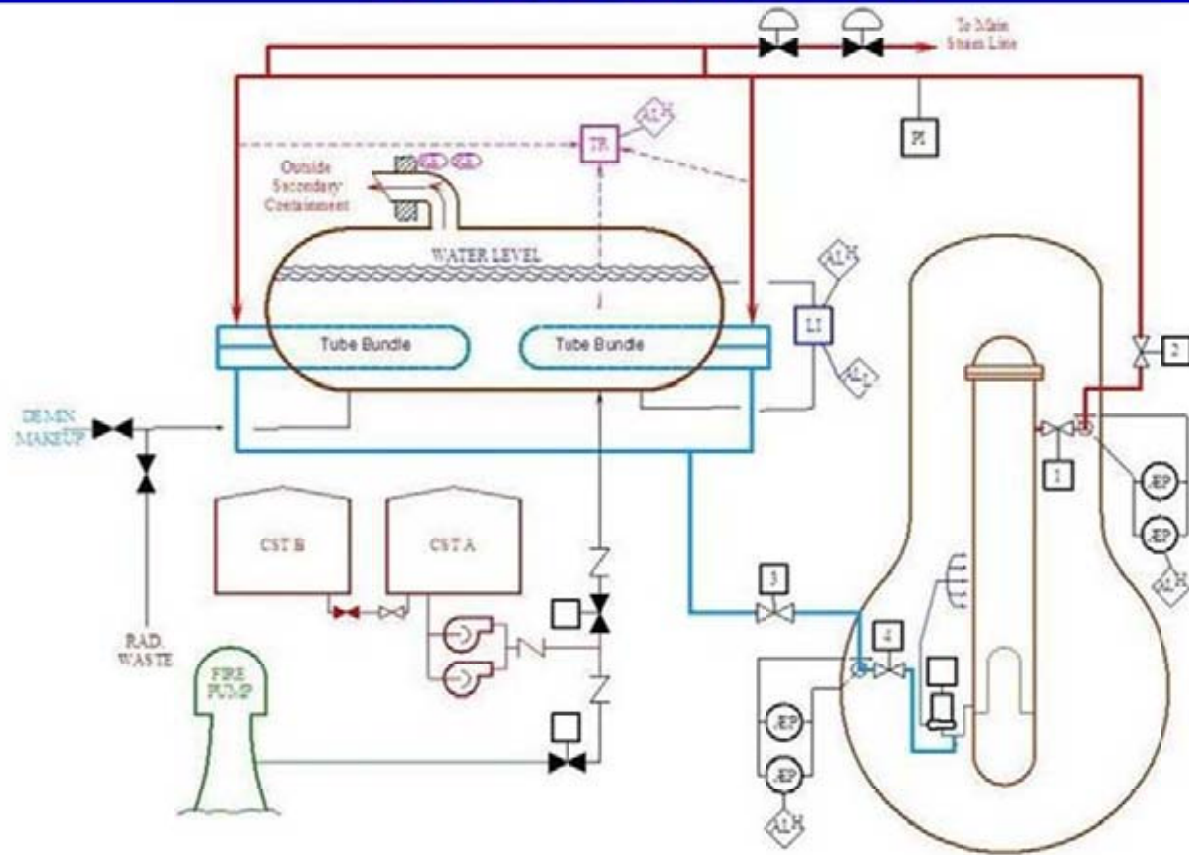

Battery power for valves would have allowed the isolation condenser (IC) to continue recycling water to the reactor vessel. But even if battery power had remained available indefinitely, the water inside the isolation condenser would have boiled within about 90 minutes. Without makeup from pump-supplied sources, passive water makeup by the IC system would have been lost.

Meltdown Clock

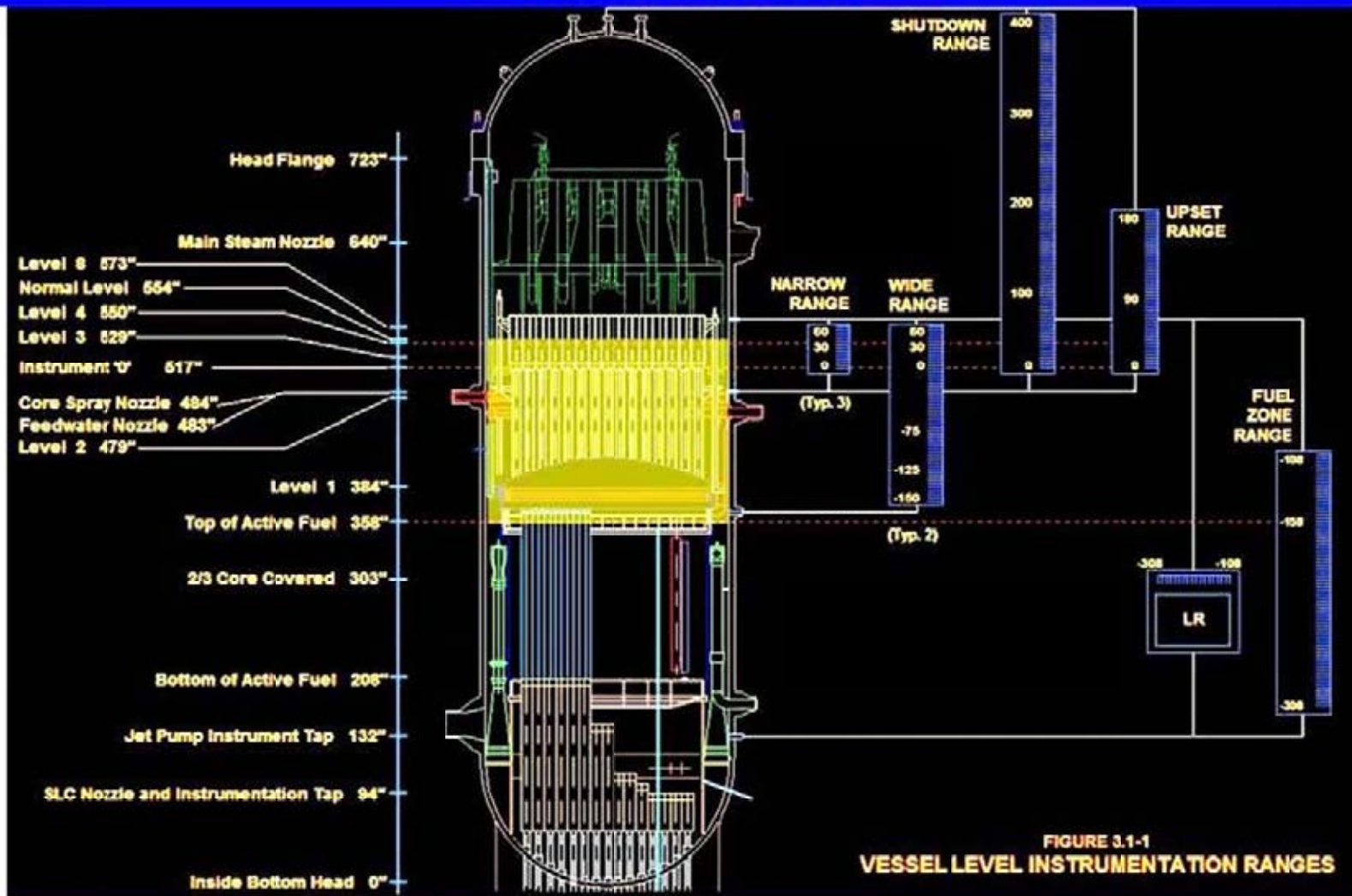

Once the makeup cooling water provided by the RCIC system or the isolation condenser was lost, the reactor core's decay heat would have begun boiling away its protective cover of water. Nearly 200 inches of water normally covers the reactor core.

Meltdown Clock

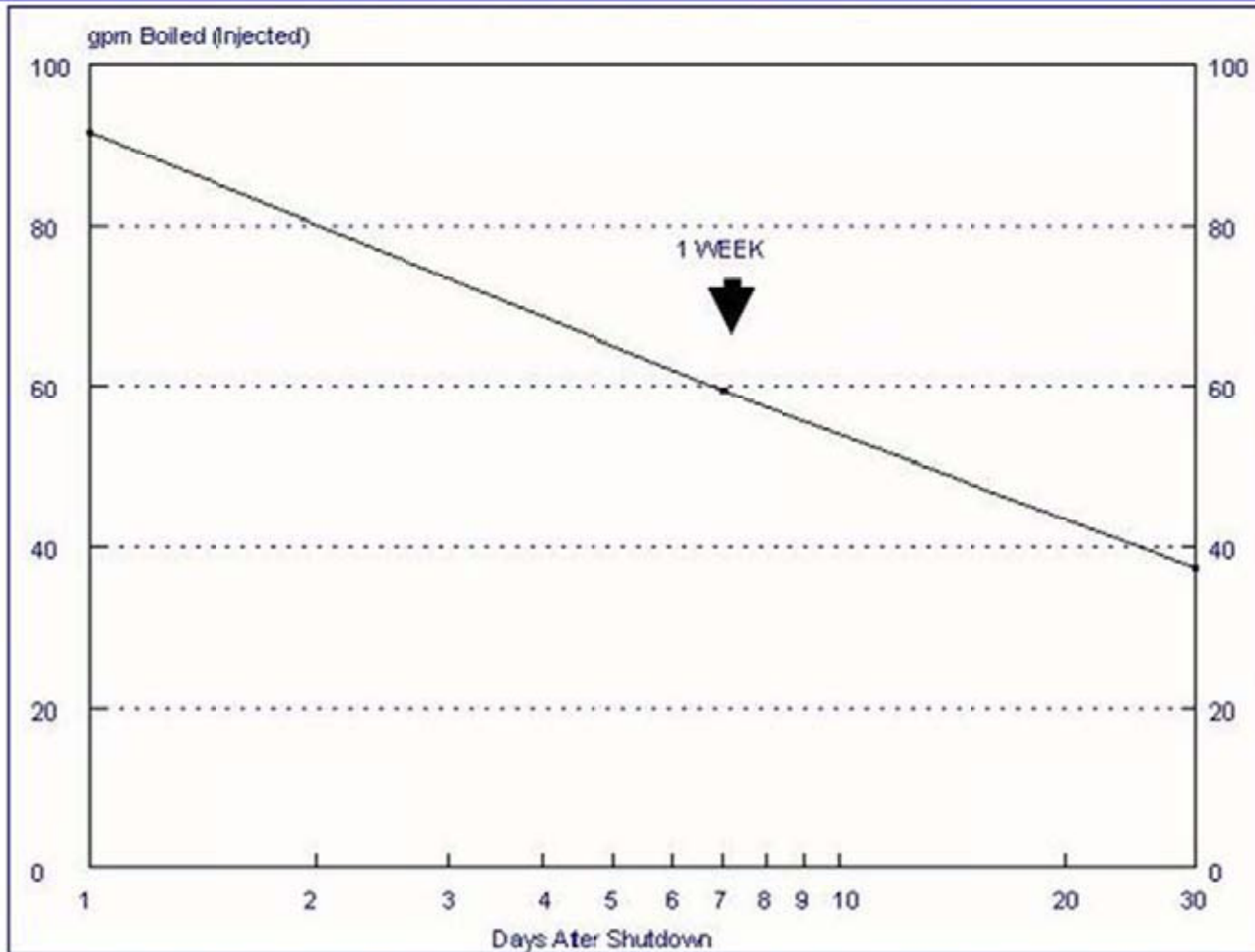

A commonly used rule of thumb is 200 gallons of water per inch of level inside the reactor vessel. That equates to about 40,000 gallons of water covering the reactor cores when makeup was lost. At a boil-off rate of 80 gallons per minute, it would take about 8 hours for water to drop to the point of uncovering the reactor cores with the associated meltdown risk.

Meltdown Clock

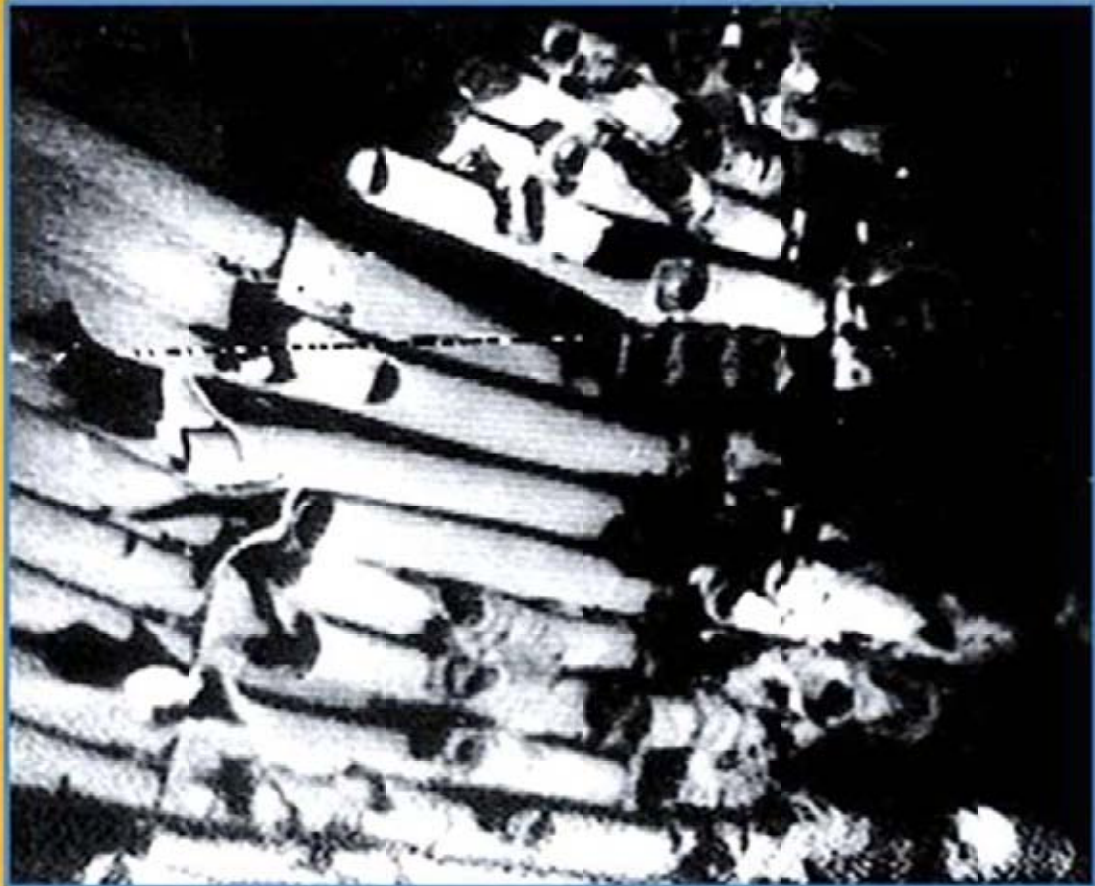

As the water level dropped below the top of the reactor core, the temperature of the cladding of exposed fuel rods would have increased. Overheated cladding would have first blistered and burst, like the rod on the left. Continued heat-up would have resulted in more extensive damage, like the portion of the Three Mile Island Unit 2 core on the right.

Meltdown Clock

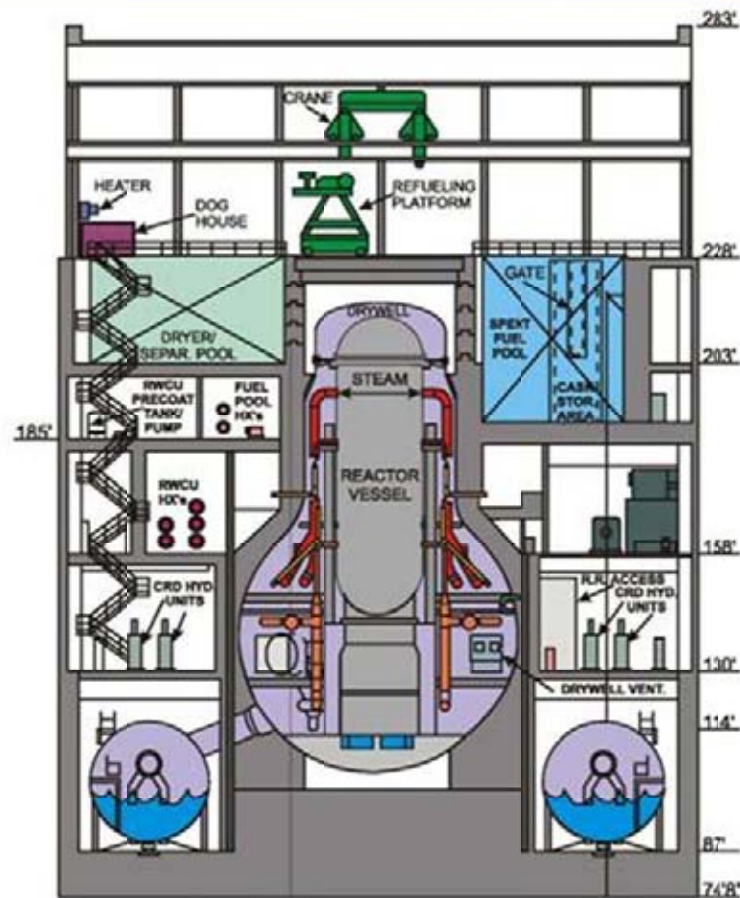

At high temperatures, the zirconium cladding for the fuel rods reacts with the steam vapor to produce large amounts of hydrogen gas. To protect against explosive mixtures, the drywell and torus airspace are inerted with nitrogen gas. The reactor building has little protection against hydrogen gas accumulation. Detonations destroyed the Unit 1, 3, and 4 reactor buildings.

More Clocks

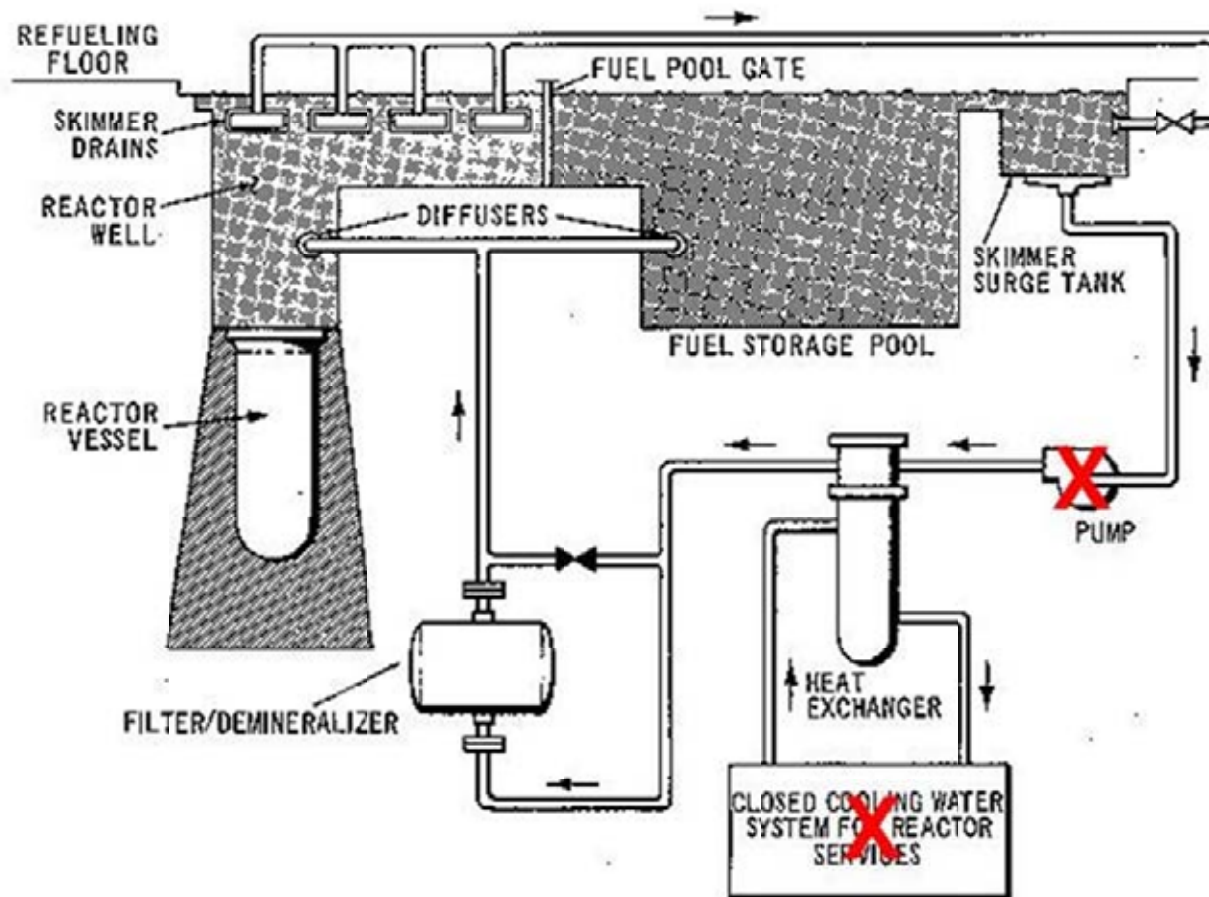

The loss of normal and backup power also left the spent fuel pools without ready means of either cooling or makeup. The decay heat from the irradiated fuel began heating the water towards boiling and then boil-off. While on a longer time frame, the outcome of fuel damaged by overheating was the same as for the reactor cores.

Containment Barriers

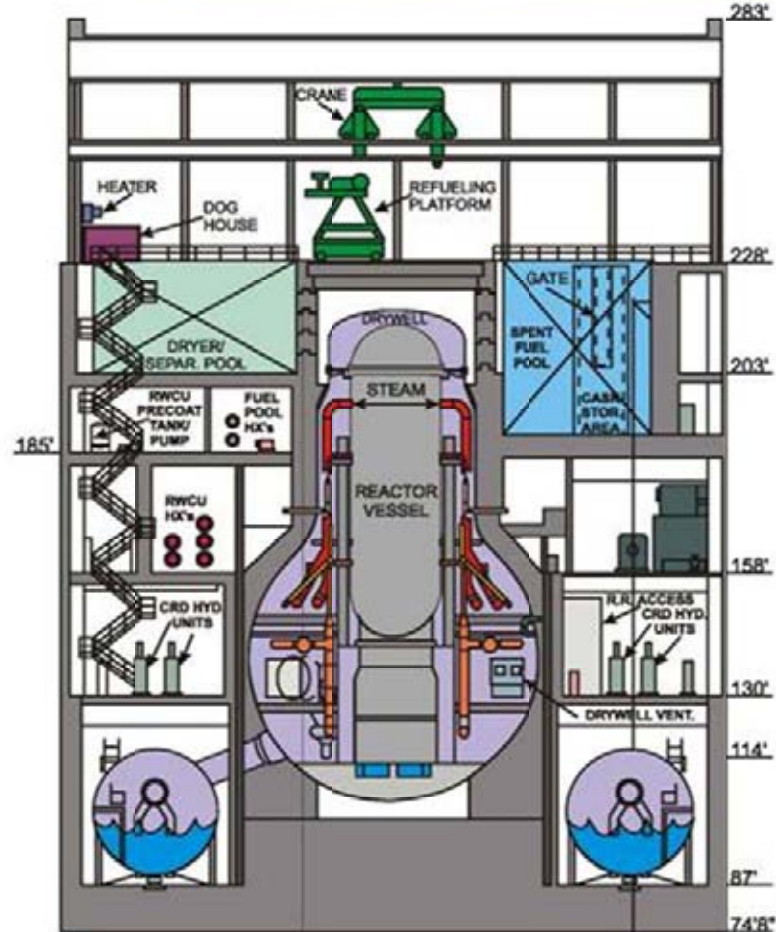

Without adequate cooling, the Unit 1-3 reactor cores and the Unit 1-6 spent fuel pools were heading towards fuel damage caused by overheating. Radioactivity released from damaged fuel in the reactor core has two barriers between it and the environment; there is but one barrier against radioactivity released from damaged fuel in spent fuel pools.

Containment Barriers



Detonations of explosive mixtures of hydrogen gas destroyed the reactor containment buildings of Units 1, 3, and 4. There are no effective barriers against radioactivity released from their spent fuel pools and one less barrier against releases from their reactor cores.

Tragedy of Unprecedented Scale

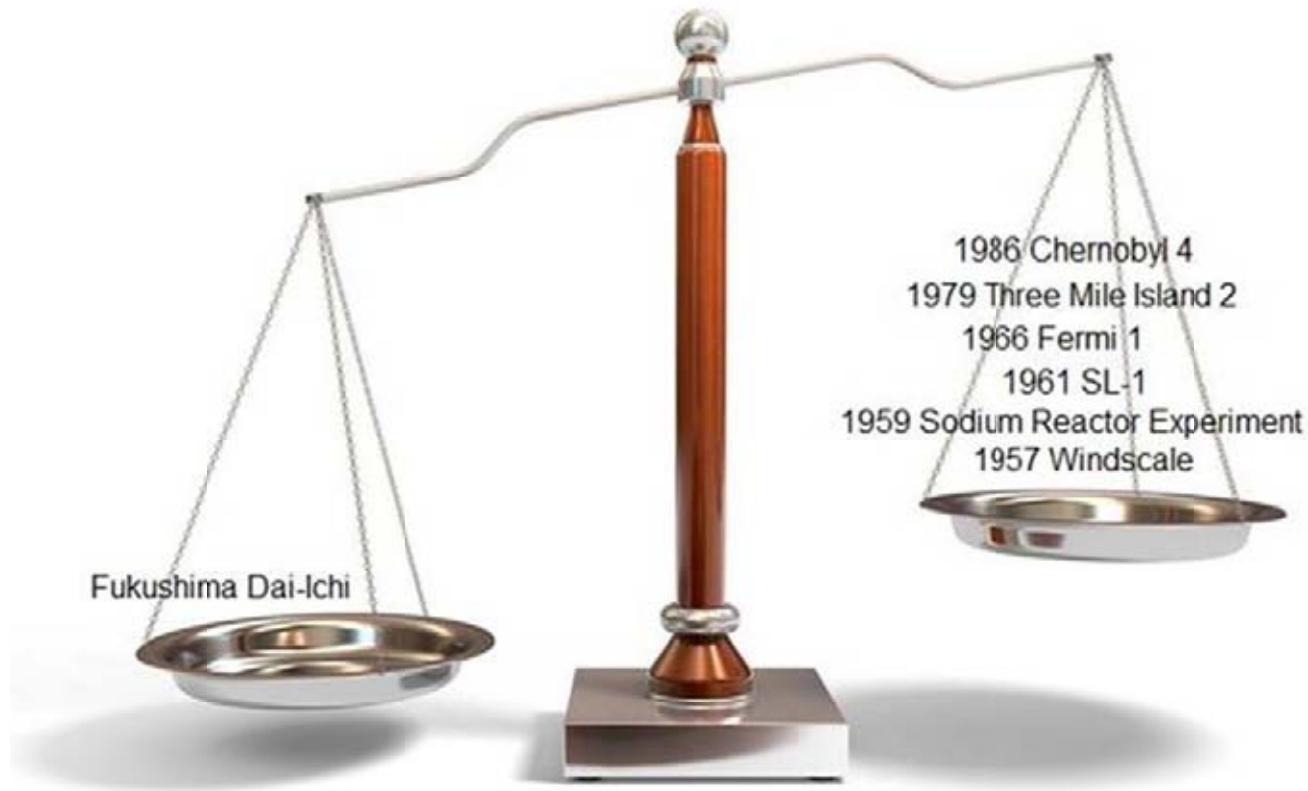

The amount of fuel damaged in the Unit 1-3 reactor cores and the Unit 1-4 spent fuel pools at Fukushima Dai-Ichi may be greater than the amount of fuel damaged in ALL past reactor accidents combined.