

CURTAINS

MEASURING

Width

Measure the track or pole, not the window.

- **For tracks:** measure the width from end to end. If the track overlaps in the middle, measure each track and combine the dimensions for the overall width.
- **For poles:** measure between the finials.

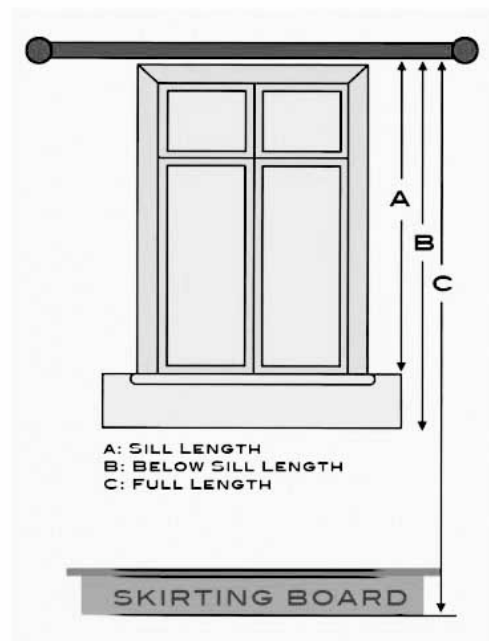

Length

Measure from:

- **For tracks:** measure from the top of the track so that it will be hidden by the curtains
- **For poles:** measure from the bottom of the curtain ring so that the pole will be seen above the curtains. For eyelet curtains, measure from the top of the pole and add 4cm

Measure to:

- **For tracks and poles:** measure to 1cm above the sill for sill length, to the required length for below sill length and 1cm above the floor for floor length (see diagram above)

HANGING AND DRESSING YOUR CURTAINS

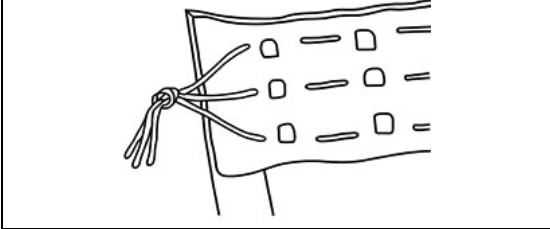
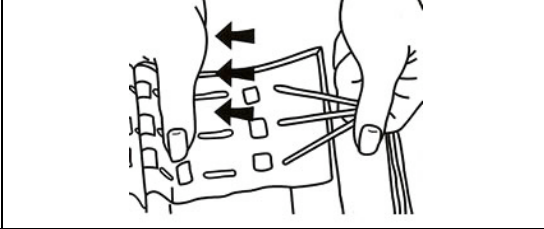
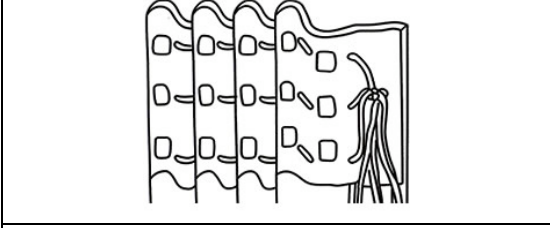
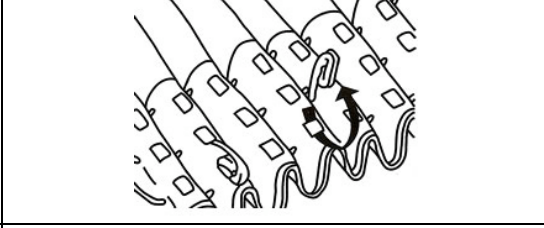
	
Fig. 1 Securely tie the three string cords.	Fig. 2 Pull the three cords at the same time, to gather the curtain in even pleats.
	
Fig. 3 Wind the surplus cord into a skein. DO NOT CUT.	Fig. 4 Heading tape has three rows for inserting hooks and setting height.

Fitting pencil pleat curtains

Before you hang your pencil pleat curtains, they need to be pulled to the width that they will be when they are closed. To do this:

Securely tie the three string cords in the heading tape at each side of the curtain. (Fig. 1)

On the side of the curtain with the string pocket, pull the three cords at the same time, to gather the curtain in even pleats to the required width. (Fig. 2)

The surplus cord can be wound into a skein and tucked into the string pocket if there is one. **DO NOT CUT** the excess cord as you will need to let the pleats out to wash or dry clean your curtains. (Fig. 3)

Hanging pencil pleat curtains

Pencil pleat heading tape has three rows for height setting. (Fig. 4) To obtain the right height:

For tracks: Insert the hooks into the lower row of pockets, so that the heading covers the track.

For poles: Insert the hooks into the top row (or middle) of pockets, so that the curtain hangs below the pole.

Check that you have the same number of hooks in each curtain as gliders on the track or rings on the pole. Don't forget to count the fixed end stop if you are using a track.

Attach each hook to a glider or ring. Your curtains are now ready to hang.

Dressing your curtains

To dress your curtains, draw them into the stack back position and, starting from the outside edge, work from the top downwards by running your hands firmly down the length of each pleat or fold.























All curtains need time to settle and it may take a few weeks for any creasing to drop out and the folds to fall correctly.

CARE

CARE INSTRUCTIONS

Care symbols give an indication of the recommended care procedures, which, if followed, should avoid the risk of damage.

NOTE: A cross through a symbol means 'DO NOT'.

		Hot wash: White cotton or linen without special finishes.		
		60°C: Cotton, linen, modal, polyester and their blends where colours and finishes are fast at 60°C.		
		40°C: Cotton or polyester in deep colours.		
		40°C, gentle program: Delicate fabrics of modal, viscose, acrylics, polyester, nylon.		
		30°C, gentle program: Shrink-resistant wool, acetate.		
		Hand wash: Normal wool, silk.		
		Do not wash: Very delicate wool and silk fabrics.		
		May be chlorine bleached.		
		Do not use chlorine bleach.		
		Cotton, linen.		
		Wool, silk, polyester, viscose.		
		Acrylic, nylon, acetate.		
		Polypropylene.		
		No limitations on the use of dry-cleaning solvents.		
				Limitations.
		Do not dry clean.		
		The divisions are similar to those for washing and ironing. Fabrics made from wool, silk and acrylics, and knitted fabrics susceptible to shrinking or stretching are not suitable for tumble drying.		
