



# 3000, 4000, 4100, 7500, 7700 Drum & Disc Brake Lathes



## *Parts Identification*

READ these instructions before placing unit in service. KEEP these and other materials delivered with the unit in a binder near the machine for ease of reference by supervisors and operators.

***HENNESSY INDUSTRIES, INC.***

1601 J. P. Hennessy Drive, LaVergne, TN USA 37086-3565 615/641-7533 800/688-6359

HENNESSY INDUSTRIES INC. Manufacturer of AMMCO®, COATS® and BADA® Automotive Service Equipment and Tools.

Manual Part No.: 940940 06

Revision: 04/06

# Parts Identification

## Table of Contents

Electrical Panel Assembly	3
Main Frame Assembly Spindle—3000, 4000, 4100, & 7700	4 - 5
Variable Drum Feed Gearbox Assembly 3037-B	6 - 7
Motor Mount and Drive Shaft	8 - 9
Disc Brake Feed Mechanism 7751-B	10 - 11
6950 Twin Cutter	12
7900 Twin Cutter & Safety Sheild	13
Crossfeed Assemblby	14
Spindle—7500	15

## Parts Identification

The following pages include full parts breakdowns with exploded view illustrations to help with ordering replacement or spare parts. Assemblies are noted where it is recommended that individual parts not be ordered separately. These parts are available only as assemblies because some parts are staked, pinned, or press fitted, then drilled, machined, or bored. Close tolerances must be maintained in assembly. Every effort is made to supply accurate exploded views, however, due to interim changes in manufacturing operations, some units may not be exactly as illustrated.

# Parts Identification

## Electrical Panel Assembly

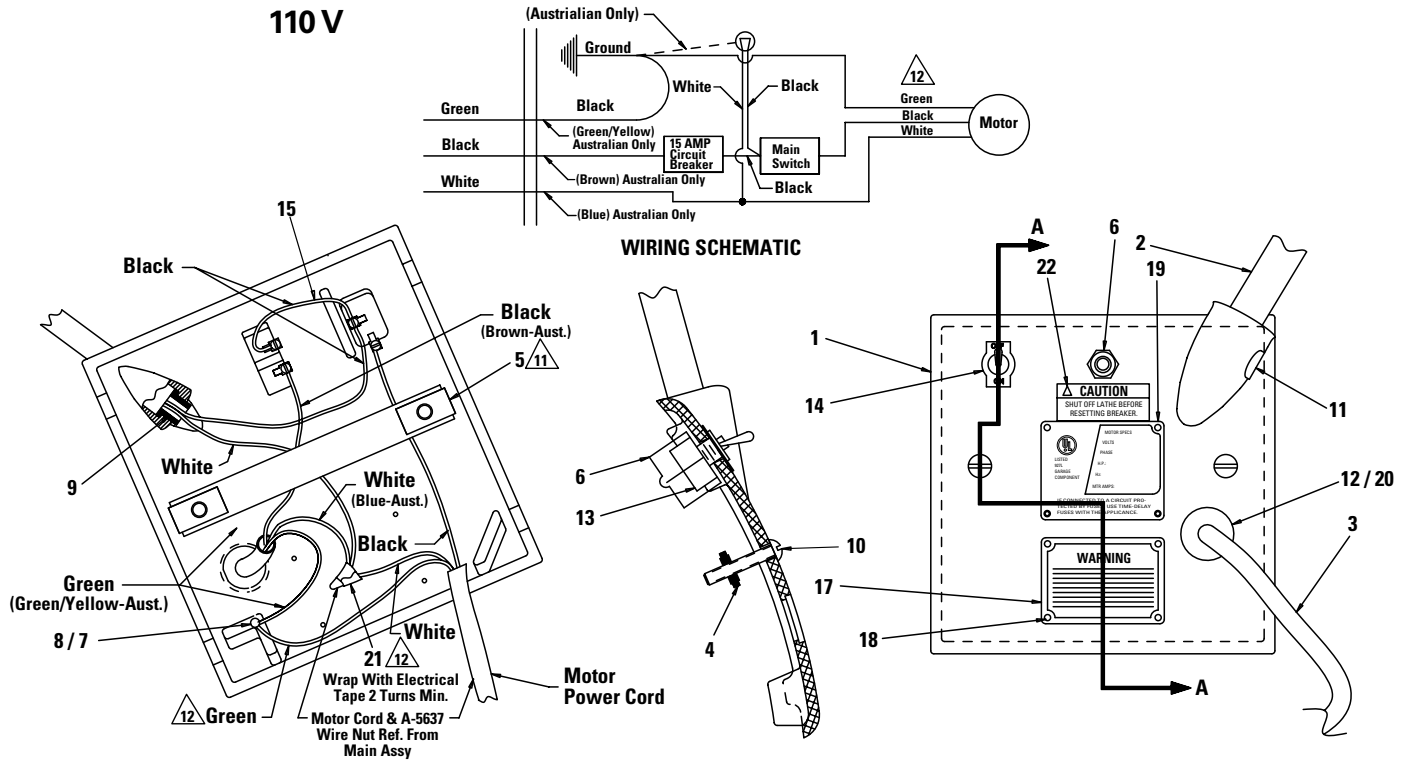

Item	Qty	Part No.	Description
1	1	910348	Electrical Panel
2	1	907963	Lamp Assembly
	1	929225	Lamp Assembly (Austrian Only)
3	1	907209	Cord Set, 110 V
	1	907210	Cord Set, 220 V
	1	929507	Cord Set (Austrian Only)
4	1	940388	Clamp Strap
5	2	81438131	Tinnerman Nut
6	1	940868	15 AMP Circuit Breaker
7	1	921972	Selt-Tapping, #6 Screw
8	1	901926	Lock Washer
9	1	906889	Bushing
10	2	903183	Round Head Machine Screw
11	1	900220	Set Screw
12	1	906058	Cord Grip, 110 V
	1	906077	Cord Grip, 220 V
	1	929643	Cord Grip, (Austrian Only)
13	1	906893	Switch, 110 V
	1	921464	Switch, 220 V
14	1	901185	Switch Plate
15	1	940988	Black Wire Assembly
17	1	920463	Electrical Caution Tag
18	8	900306	Screw, Drive
20	1	929642	Knock-out Adapter
22	1	941103	Reset Decal

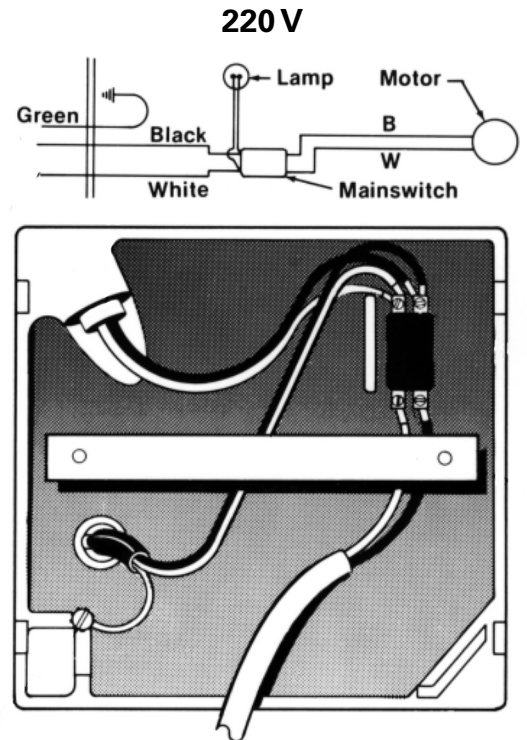

# Parts Identification

## Main Frame Assembly Spindle—3000, 4000, 4100, & 7700

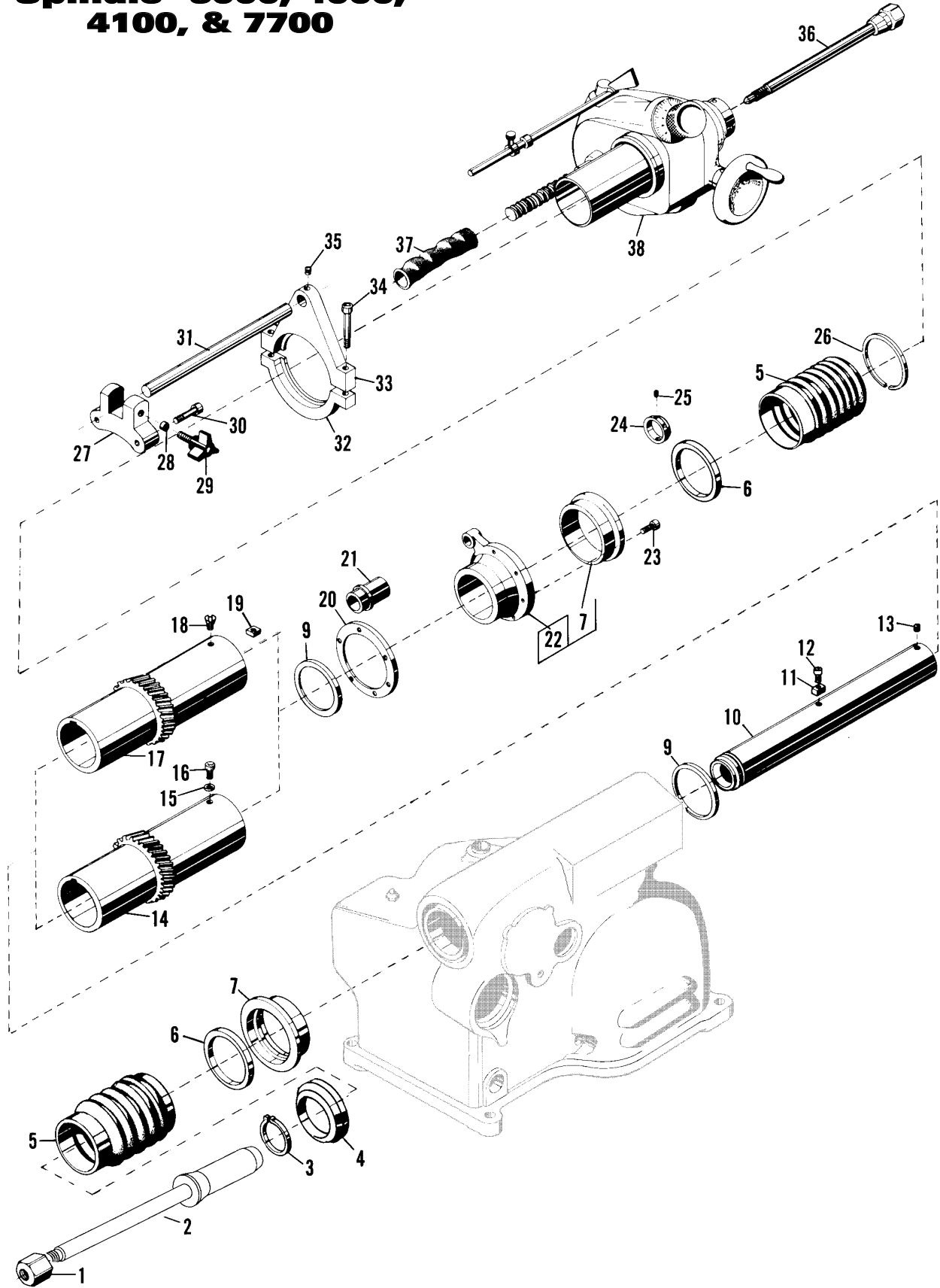

# Parts Identification

Item	Qty	Part No.	Description
1	1	903102	Nut, Arbor
2	1	903101	Arbor
3	1	903159	Ring, Retaining
4	1	923682	Ring, Adapter
5	2	903085	Boot
6	1	903164	Seal, Oil
6A	1	940720	Seal, Oil, DBL Lip
7	2	903089	Ring, Oil Seal Adapter
9	2	903033	Washer, Thrust
10	1	903153	Spindle Body, 3000/4000
		907714	Spindle Body, 4100/7700
11	1	909831	Key, Drive
12	1	906486	Screw, Socket Head Cap
13	1	903224	Screw, Cuppoint Set
14	1	909830	Quill, Drive, 3000/4000
15	1	900283	Washer, Lock, 3000/4000
16	1	901602	Screw, Hex Hd. Cap, 3000/4000
17	1	910216	Quill, Drive, 4100/7700
18	1	906868	Screw, Flat Hd., 4100/7700
19	1	910737	Block, Keyway, 4100/7700
20	*	903032	Shim (0.005 THK)
	*	921322	Shim (0.0075 THK)
21	1	904670	Nut, Lead Screw, 4000/7000
	1	907712	Nut, Lead Screw, 4100/7700
22	1	907344R	Rear Flange Assy., 3000/4000
	1	907729R	Rear Flange Assy., 4100/7700
23	6	900209	Screw, Skt. Hd. Cap, 3000/7700
	4		Screw, Skt. Hd. Cap, 4000/4100
24	1	904671	Nut, Take Up
25	1	903338	Screw, Skt. Hd. Set
26	1	904435	Ring, Boot, 4000/4100
	1	903595	Spring, Boot, 3000/7700
27	1	909592	Clamp, Front
28	1	903142	Plug, Brass
29	1	906854	Knob
30	2	903319	Screw, Skt. Hd. Cap, 4000/4100
31	1	909645	Red, Lock, 4000
	1	909593	Rod, Lock, 4100
32	1	909998	Clamp, Rear, Lower
33	1	909999	Clamp, Rear, Upper
34	2	906825	Screw, Skt. Hd. Cap
35	1	900213	Screw, Set
36	1	907005	Drawbar & Nut Assy., 3000/4000
	1	907716	Drawbar & Nut Assy., 4100/7700
37	1	903086	Boot & Spring, 3000/4000
	1	907703	Boot & Spring, 4100/7700
38	1	903037B	Feed Mechanism, 3000/4000
	1	907702	Feed Mechanism, 4100/7700

\* Quantity as Required

# Parts Identification

## Variable Drum Feed Gearbox Assembly 3037-B

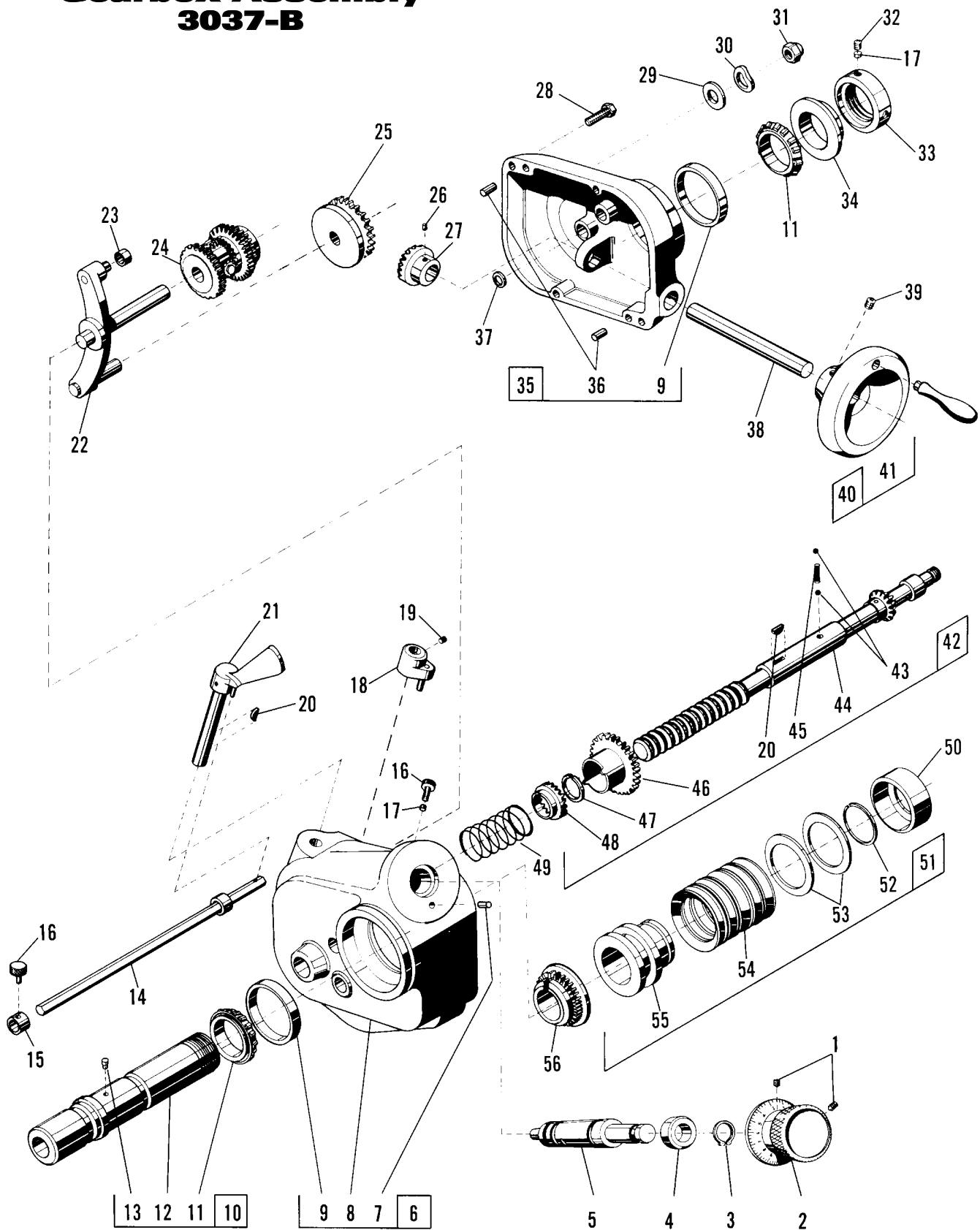

# Parts Identification

Item	Qty	Part No.	Description	Item	Qty	Part No.	Description
1	2	911241	Screw, Allen Set	31	1	903184	Nut, Stop
2	1	903043	Feed Dial Assembly	32	1	900213	Screw, Allen Set
3	1	903097	Ring, Retaining	33	1	909443	Nut, Bearing Lock
4	1	909930	Bearing, Thrust	34	1	909444	Washer, Spherical
5	1	903066	Screw, Feed Adjusting	35	1	909498	Gear Case Cover Assembly
6	1	903715	Gear Case Assembly	36	2	903038	Pin, Dowel
7	1	903132	Pin, Groove	37	1	904641	Washer, Bone Fiber
8	1	903663	Gear Case	38	1	903054	Shaft
9	1	903392	Cup, Bearing	39	1	900220	Screw, Set
10	1	907007	Spindle Extension Assembly	*40	1	903090	Handwheel Assembly
11	1	903391	Bearing, Taper Roller	41	1	903026	Handle, Crank
12	1	903154	Spindle Extension	42	1	908235	Lead Screw and Clutch Assembly 3000/4000
13	1	903092	Pin, Groove				
14	1	903040	Shut-Off Assy, 3000/4000	1	908237	Lead Screw and Clutch Assembly 4100/7500/7700	
	1	907717	Shut-Off Assy, 4100/7500/7700				
15	1	903039	Collar, Stop	43	2	900311	Ball, Steel
16	2	903084	Screw, Knurled	*44	1	909918	Lead Screw/Miter Gear Assembly 3000/4000
17	2	903141	Plug, Brass				
*18	1	903058	Clutch Shifter Assembly	1	909919	Lead Screw/Miter Gear Assembly 4100/7500/7700	
19	1	900212	Screw, Allen Set				
20	2	904449	Key, Hy-Pro	45	1	903060	Spring, Clutch
*21	1	903042	Clutch Handle And Shaft Assy.	46	1	903047	Gear, Sliding Clutch
*22	1	907343	Feed Control Lever and Differential Assembly	47	1	906163	Ring, Retaining
23	1	903036	Roller	48	1	907264	Clutch Jaw
24	1	907338	Pinion Bushing Assy.	49	1	907263	Spring, Coil
*25	1	903081	Driven Friction Disc and Bearing Assembly	50	1	903061	Cup, Spring Loading
26	1	903098	Screw, Dog Point Set	51	1	903082	Friction Disc Assy.
27	1	903069	Gear, Miter	52	1	903093	Ring, Retaining
28	4	903094	Screw, Socket Hd. Cap	53	2	903064	Washer
29	4	903324	Washer	54	10	903062	Spring, Belleville
30	1	906155	Washer, Wave	55	1	903078	Disc, Sliding Friction
				56	1	903077	Clutch, Fixed Friction

\*Sold as assembly only.

# Parts Identification

## Motor Mount and Drive Shaft

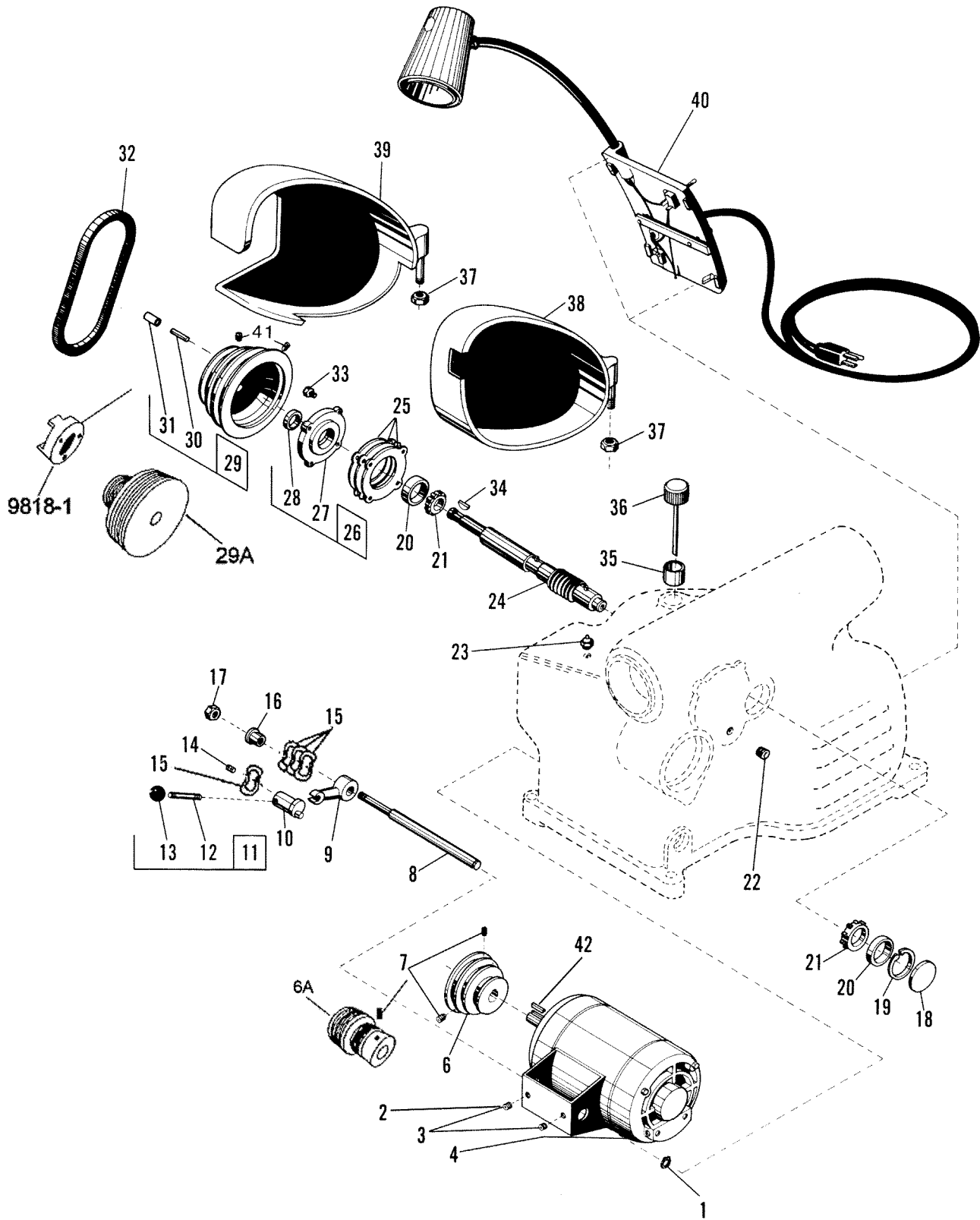



# Parts Identification

Item	Qty	Part No.	Description
1	1	906766	O-Ring
2	2	906101	Screw, Hex Hd. Cap
3	2	921557	Washer, Lock
4	1	902165	Motor/Bracket Assy.
6	1	903024	Pulley, Drive, 3000/4000**
	1	903639	Pulley, Drive, 4100/7700**
6A	1	940142	Pulley, Drive, Poly-V-Belt**
7	4	900220	Set Screw, 3000/4000/7500**
	2	900217	Set Screw, 4100/7700**
8	1	903023	Shaft, Motor Mount
9	1	903015	Lever, Belt Tension
10	1	903035	Pin, Eccentric Belt Release
11	1	907348	Lever Belt Release Assy.
12	1	903088	Handle, Belt Release
13	1	900320	Knob, Ball
14	1	903180	Screw, Socket Hd.
15	*	902364	Washer, Wave (*Qty As Required)
16	1	903223	Bushing, Motor Mount Shaft
17	1	903377	Nut, Hex
18	1	903166	Plug, Welch
19	1	903172	Ring, Retaining I.D.
20	2	903394	Cup, Bearing
21	2	903393	Bearing, Cone
22	1	903372	Plug, Allen Pipe
23	1	922006	Fitting, Grease
24	1	9847-C	Shaft, Worm W/Woodruff Keyway
	1	940140	Shaft, Worm W/Square Keyway
25	*	903169	Shim, 0.005" (*Qty As Required)
	*	903170	Shim, 0.007" (*Qty As Required)
	*	903171	Shim, 0.020" (*Qty As Required)
26	1	903186	Cap And Seal Assy.
27	1	903010	Cap, Bearing Seal
28	1	903163	Seal, Oil
29	1	907784-1	Pulley W/Pin & Tube**
29A	1	940146-2	Pulley W/Pin & Tube, Poly-V-Belt**
30	1	924239	Pin, Groove, 4000/4100
31	1	925588	Tube, Rubber, 4000/4100
32	1	903161	V-Belt, 3000,4000**
	1	910241	V-Belt, 4100/7700**
	1	940141	Poly V-Belt**
33	1	900236	Screw, Hex Hd. Cap
34	1	924446	Key, Woodruff
	1	940139	Key, Square
35	1	903215	Sleeve, Oil Filler
36	1	903148	Dipstick
37	1	911273	Nut, Self-Locking
38	1	903005	Guard, Belt, 3000/7700
39	1	907788	Guard, Belt, 4000/4100/7500
40	1	910352	Panel Assy., Electrical
41	2	900220	Screw, Set**
42	1	925454	Key, Square
*	1	940175	Kit, Poly-V-Belt
*	1	941260	Kit, Standard V-belt, 4100

\*\* Check your unit to see if it uses the 3-groove pulley and standard V-belt or the 2-groove pulley and poly V-belt. Order the pulley, set screw, and V-belt that matches your unit.

# Parts Identification

## Disc Brake Feed Mechanism 7751-B

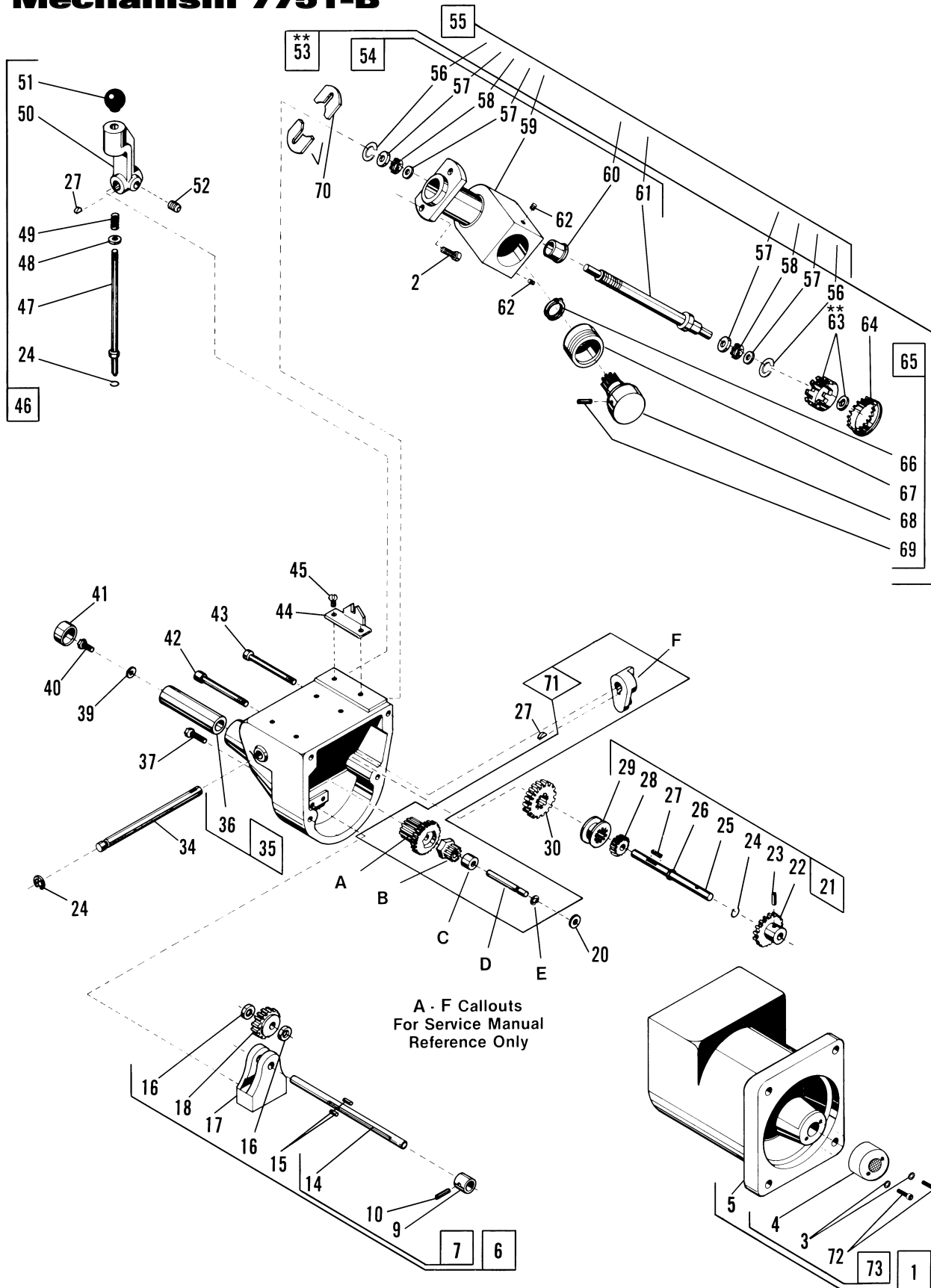

# Parts Identification

Item	Qty	Part No.	Description	Item	Qty	Part No.	Description
1	1	910870	Gear Case Assembly	46	1	907742	Shifter Handle Assy.
2	4	903221	Screw, Socket Head	47	1	907746	Pin, Shifter Handle
3	2	903910	Washer, Lock	48	1	906451	Washer
5	1	907790	Case, Gear	49	1	907699	Spring
4	1			50	1	907744	Body, Shifter Handle
*6	1	940718	Drive Rod and Coupling Assy.	51	1	900320	Knob, Ball
*7	1	940719	Universal Coupling Assy.	52	1	900220	Screw, Set
*9	1	940717	Coupler	**53	1	909815	Driven Assy., Right Angle Drive
*10	1	940403	Pin, Roll	54	1	924241	Worm Drive Assy.
14	1	907774	Rod, Drive	*55	1	940401	Worm Shaft Repair Kit
15	2	906937	Pin, Dowel	*56	1	905639	C Clip
16	2	906973	Washer, Thrust	*57	2	906872	Washer, Travel
17	1	907775	Trap	58	1	906871	Bearing, Needle Thrust
18	1	907778	Gear, Drive	59	1	907998	Housing, Drive
20	1	906350	Washer, Bone Shim	60	1	906749	Bushing, Oilite
21	1	909814	Shifter Shaft Assy.	*61	1	907997	Worm Drive Assy.
22	1	907994	Gear, Helix	62	2	906834	Screw, Cone Point Set
23	1	904006	Pin, Roll	**63	1	907996	Shear Gear And Ring Assy.
24	2	905613	Ring, Retaining	64	1	906446	Plug, Dot
25	1	907764	Shaft, Clutch	65	1	909821	Coupling Assy.
26	1	906138	Ring, Retaining	66	1	903174	Ring, Retaining
27	5	903176	Key, Woodruff	67	1	909825	Spacer And Bushing Assy.
28	1	909816	Gear, Fine Feed	68	1	909822	Coupling And Gear Assy.
29	1	909813	Clutch	69	1	904096	Pin, Roll
30	1	909812	Gear, Coarse Feed	70	2	907908	Shim, 0.005"
34	1	907748	Shaft, Shift		2	907903	Shim, 0.010"
35	1	907902	Gear Case Cover and Tube Assy.		2	907904	Shim, 0.020"
36	1	907783	Tube		2	907905	Shim, 0.030"
37	2	903221	Screw, Socket Hd. Cap	71	1	924516	Shifter & Intermediate Gear Assy.
39	1	904789	Washer	72	2	928367	Screw, Cap
40	1	906254	Screw, Socket Hd. Cap	73	1	928529	Lead Screw Nut Kit
41	1	906974	Cap, Tube				
42	2	906392	Screw, Hex Hd. Machine				
43	2	906391	Screw, Hex Hd. Machine				
44	1	907747	Plate, Index				
45	2	904508	Screw, Round Hd. Machine				

\*Sold as assembly only.



**\*\* The 940907 metal face gear can only be used in conjunction with lathes equipped with a circuit breaker located on the electrical panel.**

**The plastic 907996 shear gear must be used on lathes without the circuit breaker. Failure to follow these instructions may lead to minor personal injury or product or property damage.**

# Parts Identification

## 6950 Twin Cutter

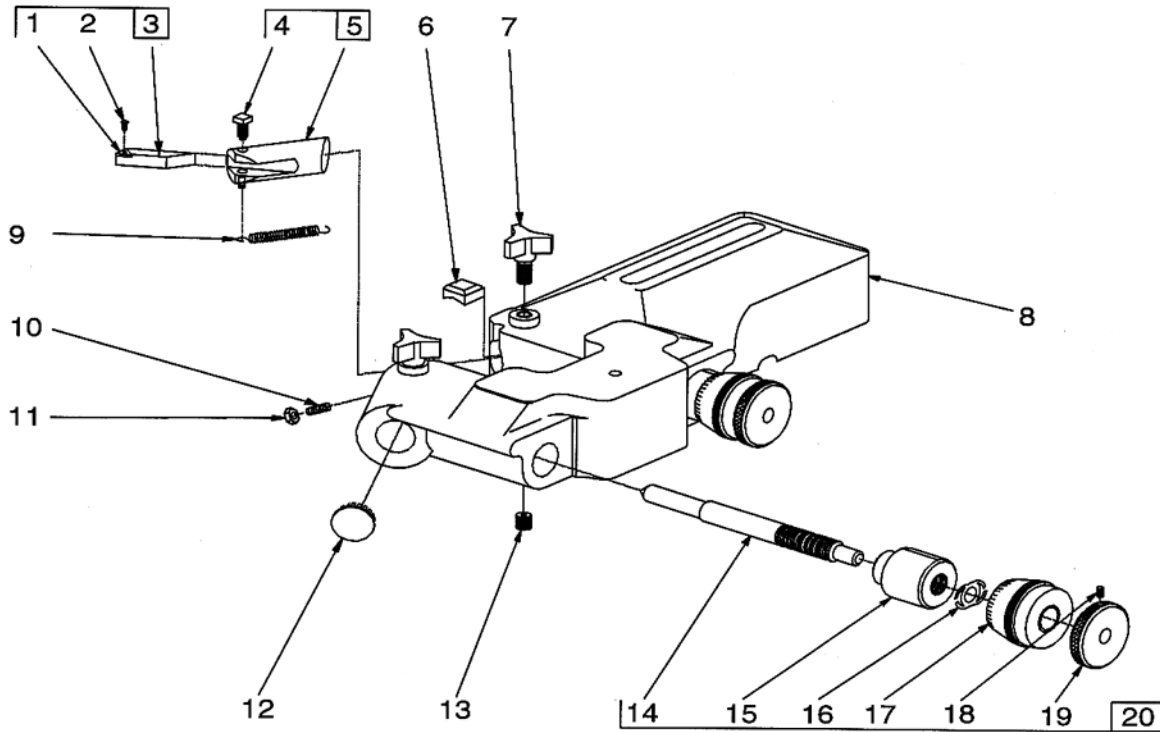

Item	Qty	Part No.	Description
*1	2	906918	Carbide Insert, Positive Rake
**	2	906914	Carbide Insert, Negative Rake
	2	906499	Screw, #4-40 X .25 Oval Head
*3	1	925968	Holder, Tool Bit, RH, Positive Rake
*	1	925969	Holder, Tool Bit, LH, Positive Rake
**	1	910701	Holder, Tool Bit, RH, Neg. Rake
**	1	910702	Holder, Tool Bit, LH, Neg. Rake
4	2	909249	Screw, Square Head Set
5	1	910650	Tool Holder, Left Hand
	1	910651	Tool Holder, Right Hand
6	2	928584	Gib, Brass, Tool Holder
7	1	906854	Screw, Lock
8	1	928572	Twin Cutter Housing
9	1	906905	Spring
10	2	909879	Screw, Locating
11	2	903528	Nut, Hex
12	2	906977	Plug, Dot

Item	Qty	Part No.	Description
13	2	906109	Screw, 3/16-16 Set
14	2	906908	Rod, Dial
15	2	906906	Plug, Dial
16	2	906929	Washer, Spring
17	2	906907	Dial, Micrometer
18	2	903338	Screw, Set
19	2	906923	Knob, Dial Rod
20	1	906901	Dial Assembly

**Note:** These parts are not included with the 6950 Twin Cutter tool.

For a complete assembly, order one of the following:  
 \*28800 twin cutter with positive rake tool holders and bits.  
 \*\*29800 twin cutter with negative rake tool holders and bits.

# Parts Identification

## 7900 Twin Cutter & Safety Shield

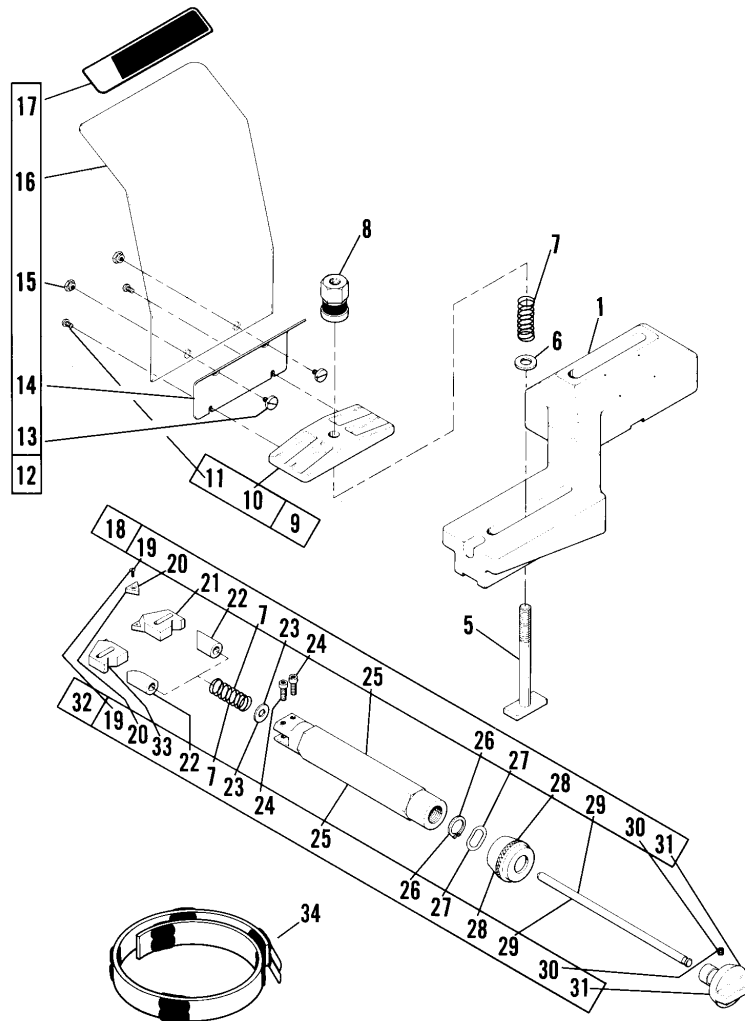

Item	Qty	Part No.	Description	Item	Qty	Part No.	Description
1	1	925982	Support, Tool Bar	20	1	906914-2	Bit, Carbide, Package Of 2
5	1	923556	Bolt, T	21	1	925762	Holder
6	1	903214	Washer, Flat	22	1	925754	Sleeve
7	3	925756	Spring, Compression	23	1	924922	Washer, Flat
8	1	911227	Nut/Washer, Hex, Self-Align, Assy	24	1	925757	Screw, Shoulder
9	1	926018	Clamp Assy.	25	1	925984	Bar, Boring
10	1	925985	Clamp	26	1	925759	Ring, Retaining, External
11	2	904508	Screw, Pan Hd., Machine	27	1	925758	Washer, Wave
12	1	926015	Shield Assy.	28	1	925752	Dial, Micrometer
13	2	911150	Screw, Retainer	29	1	925983	Rod, Dial
14	1	926014	Bracket	30	1	903338	Screw, Set, Cup Point
15	2	911166	Insert, Nut	31	1	925751	Dial, Depth
16	1	911154	Shield	32	1	925981	Bar, Tool, LH, Assy.
17	1	926016	Decal, Safety	33	1	925761	Holder
18	1	925980	Bar, Tool, RH, Assy.	34	1	906930	Band, Silencer, HD, Assy.
19	1	906499	Screw, Oval Hd., Machine				

# Parts Identification

## Cross Feed Assembly

Models 4000, 4100 & 7500 Only

Item	Qty	Part No.	Description	Item	Qty	Part No.	Description
1	1	907345	Cross Feed Assembly	14	1	909611	Spring, Dial
2	1	911227	Nut/Washer, Hex, Self-Align, Assy.	15	1	909633	Handwheel
3	1	911221	Nut, Locking	16	1	903026	Crank, Handwheel
4	1	911225	Retainer	20	1	900220	Screw, Set
5	1	911224	Washer	21	1	902064	Spring
6	1	903017	Clamp, Boring Bar, Upper (Except 7500)	22	1	909836	Plug
7	1	920666	Clamp, Boring Bar, Lower (Except 7500)	25	1	906873	Bearing, Needle Thrust
8	1	903031	Stud, Boring Bar	26	1	903211-1	Lead Screw Assembly
9	1	909835	Crossfeed	29	1	910346	Bar, Guide
10	3	906874	Race	31	1	907751B	Gearbox Assy., 4000/4100/7500
11	1	909626	Crossfeed Handwheel Assembly	32	4	900237	Screw, Cap 4000/4100/7500
12	1	906839	Screw, Set	33	4	901127	Screw, Cap 3000/7700
13	1	909634	Dial	34	1	903007	Cap, Lead Screw, 3000/7700
				35	1	900237	Nut, 3000/7700

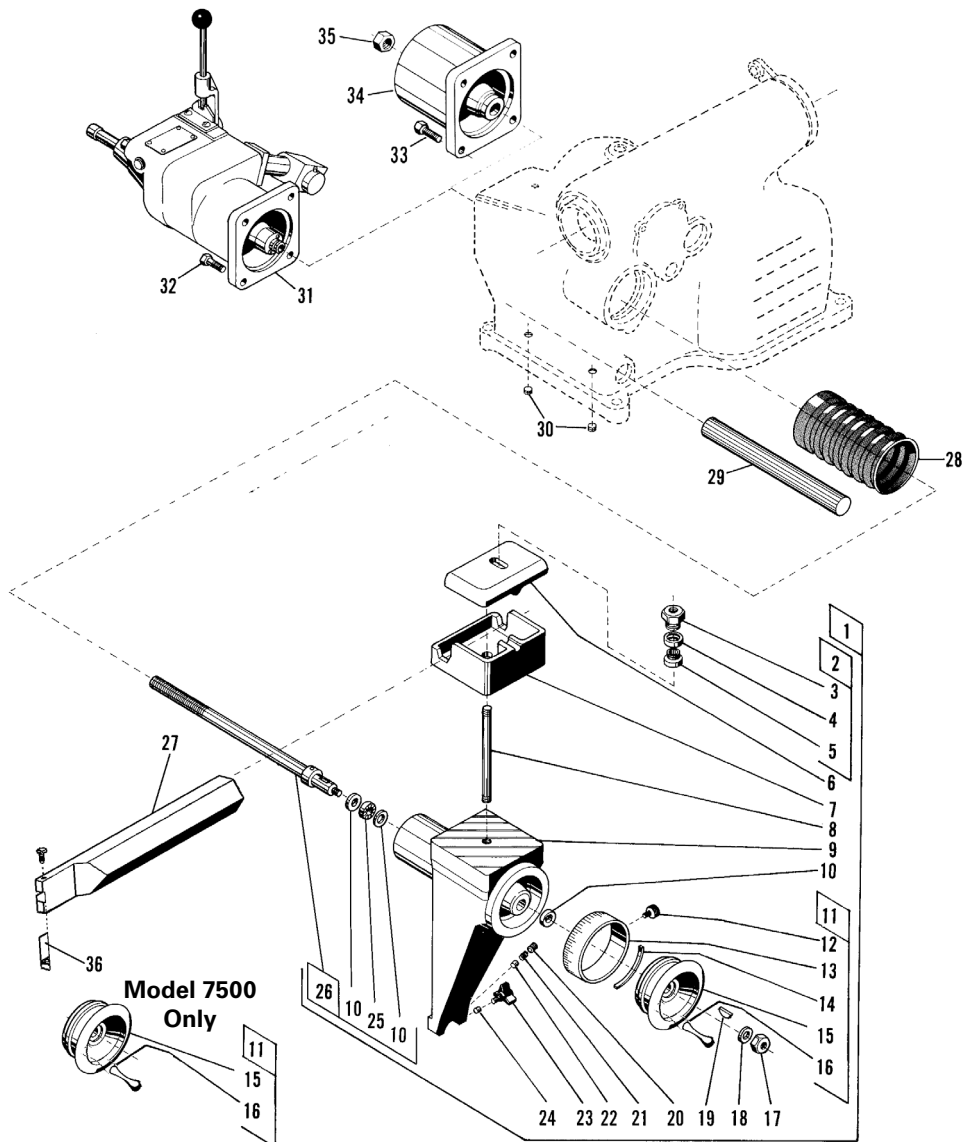

# Parts Identification

## Spindle—7500

		Part	
Item	Qty	No.	Description
1	1	903102	Nut, Arbor
2	1	903101	Arbor
4	1	940720	Seal, Oil
5	1	940021	Spindle And Gear Assy.
*5A	1	910315-1	Spindle Gear
*5B	1	903177	Roll Pin
6	1	910303	Spacer
7	2	906979	Bearing
8	1	903032	Shim
9	1	910316	Flange, Rear
10	6	900209	Screw
11	1	906981	Washer, Lock
12	1	906980	Nut, Lock
13	1	910364	Drawbar

