



MIDWEST MODERN®
SEWING PATTERNS

*Free
Pattern!*

nigella
Yoga Bag



“Nigella Yoga Bag”

NOTE: All seams are 1/2" Unless otherwise stated (The 1/2" seam allowance is included in all the measurements and the pattern piece)

Please read through all of the instructions before you get started on your project. Preshrink your fabric by washing, drying and ironing it before beginning.

Materials List:

For 44" wide light to mid-weight fabric

-1 1/4 yards for the Exterior

-7/8 yard for the Lining

-2 1/8 yards Stacy's Shape Flex" from Pellon

OR

54" heavier Home Dec fabric

-1 yard for the Exterior

-7/8 yard for the Lining

PLUS

1 spool of a coordinating all-purpose thread (We use Coats Dual Duty Plus")

Tools Needed:

Yardstick

Chalk pencil or fabric marker

Scissors

Straight Pins

Iron

Finished size: 5 3/4" diameter x 24 1/2" tall

NOTE: The first time a term is mentioned and followed by an asterisk (*), it will be defined in the Glossary.

Step 1.

CUT THE PIECES OUT OF YOUR FABRIC

A. First using your scissors cut out the Bottom Panel pattern piece.

B. Using your yardstick and chalk pencil measure and mark the measurements directly onto the **WRONG** side of both the Exterior and Lining fabrics as indicated below.

From the Exterior fabric

-Cut 1 Main Panel – 19" wide x 27" long

-Cut 1 Outside Pocket – 19" wide x 12" long

-Cut 1 Strap – 14" wide x 34" long

-Cut 1 Bottom Panel

From the Lining fabric

-Cut 1 Main Panel – 19" wide x 27" long

-Cut 1 Outside Pocket – 19" wide x 12" long

-Cut 1 Bottom Panel

From the Stacy Shape-Flex interfacing (For the lighter weight fabric)

-Cut 1 Main Panel – 19" wide x 27" long

-Cut 1 Outside Pocket – 19" wide x 12" long

-Cut 1 Strap – 14" wide x 34" long

-Cut 1 Bottom Panel

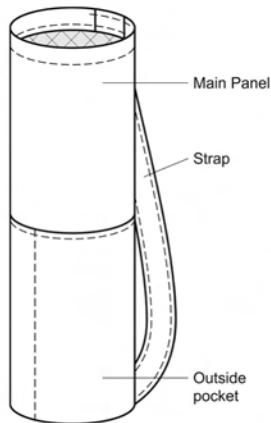

Step 2.

ATTACH THE INTERFACING

A. Place the fusible side of the interfacing pieces onto the **WRONG** side of the exterior Main Panel, Outside Pocket, Strap and Bottom Panel. Follow the manufacturers instruction to fuse the interfacing to these panels.

Step 3.

MAKE THE STRAP

A. Fold the Strap in half lengthwise **WRONG** sides together and press a center crease, then open up the Strap.

B. Fold each long edge in toward the center and press. Then fold the Strap in half again at the center crease enclosing the raw edges and press. Edge stitch* along the long folded edges, and backstitch* at each end.

Set your Strap aside.

Step 4.

MAKE AND ATTACH THE OUTSIDE POCKET TO THE MAIN PANEL

A. Place the Outside Pocket and Pocket Lining **RIGHT** sides together matching the edges, and pin them in place. Stitch a 1/2" seam across the top edge and backstitch at each end.

B. Turn the Pocket **RIGHT** side out pressing it flat. Topstitch* 1/2" from the top finished edge, and backstitch at each end.

C. Machine baste* 1/4" seam down both sides and across the bottom raw edge to hold the panels together.

D. Next place the Lining side of the Outside Pocket onto the **RIGHT** side of the Exterior Main Panel matching the side and bottom edges, and pin them together. Machine baste 1/4" seam around the edges to hold them in place. Press the panels flat.

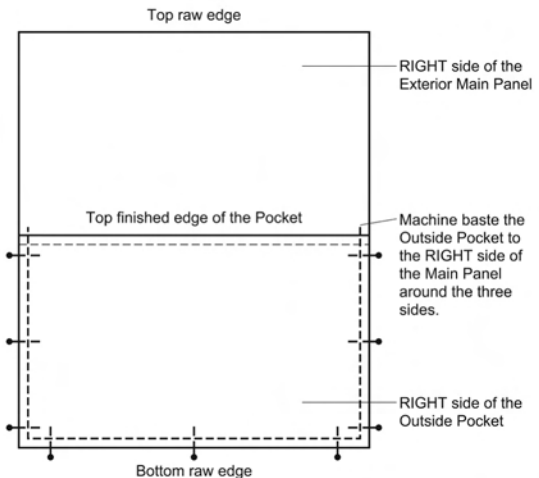

E. Using your ruler and chalk pencil, measure and mark across the top edge of the Pocket at 6 1/2" and 12 1/2". Mark the same measurements across the bottom edges.

Match the first top and bottom marks and draw a line connecting them. Then draw a line connecting the second set of marks.

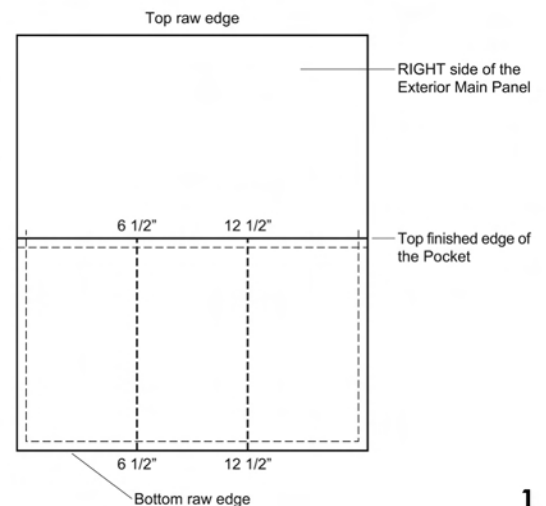

F. Starting at the bottom edge, stitch along the guidelines to the top of the Pocket, backstitching at each end.

**Step 5.
ATTACH THE STRAP AND MAKE THE EXTERIOR OF THE CASE**

A. Fold the Exterior Main Panel in half lengthwise **RIGHT** sides together matching the side edges, and pin them in place. Stitch a 1/2" seam and backstitch at each end.

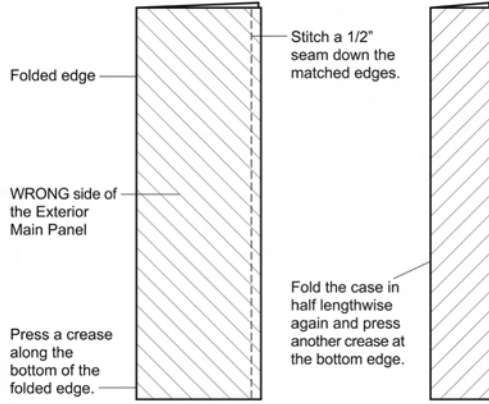

B. Then gently press a crease along the folded edge at the bottom of Main Panel. Next fold the panel in half lengthwise again and press another crease at the bottom edge. The creases will mark the bottom of the panel into quarters to use when attaching the Bottom Panel. Press the seam allowance* open.

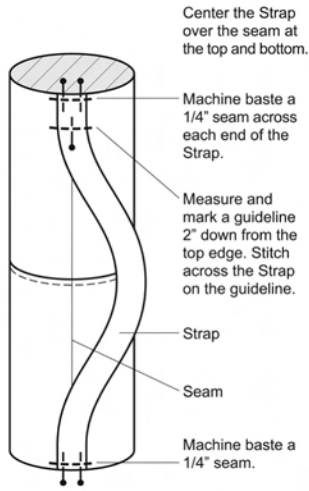

C. Now turn the panel **RIGHT** side out. Center one end of the Strap over the seam at the top edge of the Main Panel and pin it in place. Then center the other end over the seam at the bottom, making sure not to twist the Strap and pin in place. Then machine baste a 1/4" seam across each end of the Strap.

D. Measure and mark 2" down from the top edge on each edge of the Strap and draw a line connecting them. Make sure the Strap is centered over the seam on the panel at the 2" mark and pin it in place. Stitch across the Strap on the guideline, and backstitch at each end. Turn the panel **WRONG** side out.

E. Sew a 1/2" stay stitching* line around the bottom of the Main Panel. Clip into the seam allowance every 1/2" making sure not to cut your stitching.

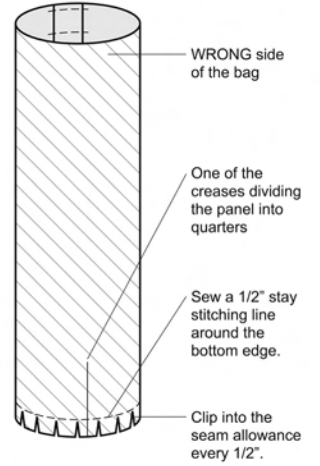

F. Next divide the Bottom Panel into quarters by folding it in half matching the edges and press a crease. Then fold it again and press another crease. Open up the Panel.

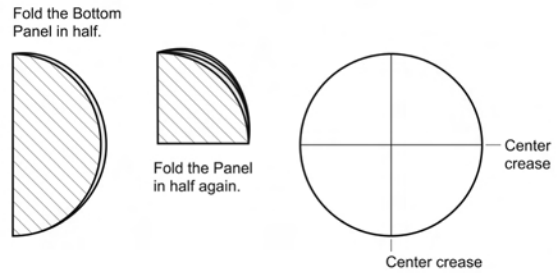

G. With **RIGHT** sides together match each of the creases on the Bottom Panel with the ones marked along the bottom edge of the Main Panel and pin them together. Ease the rest of the edges around the Bottom Panel and pin them in place. Stitch a 1/2" seam and backstitch at each end.

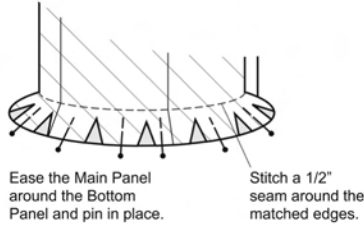

H. Turn the Exterior Case **RIGHT** side out.

Step 6.

MAKE AND ATTACH THE LINING TO THE EXTERIOR CASE

A. First repeat Steps 5A and 5B to attach the Main Panel and mark the bottom edge into quarters. Then repeat Steps 5E through 5G to attach the Bottom Panel to the Main Panel.

B. With the **RIGHT** side of the Exterior of the Case facing out and the **WRONG** side of the Lining out, slip the Exterior over the Lining placing them **WRONG** sides together. Match the top edges and pin them in place. Machine baste a 1/2" seam around the top edge.

C. Fold 1/2" under along the top edge toward the Lining side of the Case and press. Then fold it under again 1 1/2" and press. Pin the folded edge in place.

D. Measure and mark 1 1/2" down from the top folded edge on each side of the Strap and draw a line connecting them. Make sure the Strap is centered over the seam on the panel at the 1 1/2" mark and machine baste the Strap in place. Then on the inside of the bag, edge stitch along the inner folded edge and backstitch at each end.

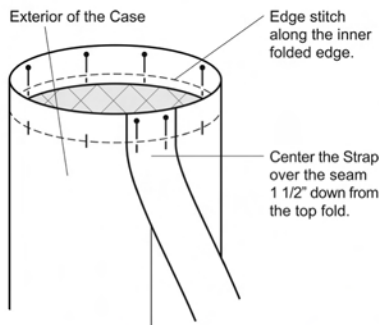

Your bag is complete! Roll up your Yoga mat and put it in the bag. Off you go.

Glossary for the Yoga Bag

-Backstitch - This is used to reinforce your stitching to keep it from unraveling. To do this, put your machine in the reverse position and stitch 3 or 4 stitches.

-Edge stitch - An edge stitch is a very narrow stitch, done by machine close to the edge, in order to finish a project, close an opening, or stitch something in place.

-Machine-baste - A machine basting stitch is used to hold sections of your project in place until you are ready to complete your final stitches. Use the longest stitch on your machine, so you can easily remove these basting stitches later. You do not have to backstitch at the end of your stitching.

-Seam allowance - The seam allowance is the fabric extending from the stitching line to the edge. It can be pressed open or to one side.

-Topstitch - Topstitching is used for several purposes. It finishes your project and gives it a neat appearance; it is used to close openings left for turning your project **RIGHT** side out; and it can be used as a reinforcement stitch, by adding another row of stitching to areas that will be used heavily and receive more wear. To topstitch stitch parallel to an edge or another seam for the distance suggested in the projects

-Stay stitching - Stay stitching is sewn in the seam allowance before construction to stabilize curved or slanted edges so the fabric on these edges does not stretch.



SEWING PATTERN INCLUDES: Instructions, pattern pieces and measurements to create your own **NIGELLA YOGA BAG**.

Sleek and practical. Ideal for taking your yoga mat to classes or stowing it away at home.

Fabrics shown is from Amy's **NIGELLA™** collection by Rowan.

All designs © 2007 Amy Butler Art of the Midwest

All designs, photographs, and images protected by federal copyright. Designs not to be created for commercial sale. All rights reserved. Art of the Midwest, LLC

Printed and produced entirely in the USA