

HPL

7007/LL 575W 230V 1CT



HPL lamps include a barrel-shaped filament that is approved by ETC for use in its Source Four™ fixtures. Bright, high quality light and high beam intensity is assured by the optimal filament design, while the unique P3 technology, developed by Philips, allows the lamp to be used at higher temperatures, which extends lifetime and consistency of high-quality light output, resulting in fewer early failures and fewer maintenance man hour costs.

Product data

• General Characteristics

Philips Code	7007/LL
System Description	P3 Technology
Cap-Base	Heat Sink
Cap-Base Information	Heat Sink
Bulb Finish	Clear
Filament Shape	Bi-Plane
Operating Position	any
Main Application	Entertainment
Life to 50% failures	1500 hr

• Light Technical Characteristics

Color Rendering Index	100 Ra8
Color Temperature Technical	3050 K
Luminous Flux Lamp	11760 Lm

• Electrical Characteristics

Watts	575 W
Voltage	230 V
Dimmable	Yes
Rapid Acting HBC	4 V
Fuse	

• Luminaire Design Requirements

Pinch Temperature	480 (max) C
-------------------	-------------

• Product Dimensions

Overall Length C	104 (max) mm
Diameter D	19 (max) mm
Light Center Length L	60.3 mm
Filament Dimensions (WxH) [mm]	8,5x11.5x7.5
Filament Height H	11.5 mm
Filament Length W	8.6 mm
Filament Depth D1	7.5 mm

• Product Data

Product number	145656
Full product name	7007/LL 575W Heat Sink 230V 1CT
Short product name	7007/LL 575W Heat Sink 230V 1CT/10
Pieces per Sku	1
eop_pck_cfg	10
Skus/Case	10
Bar code on pack	8711500185358
Bar code on case	8711500185464
Logistics code(s)	924555044228
eop_net_weight_pp	0.051 kg

Dimensional drawing

Dimensional drawing

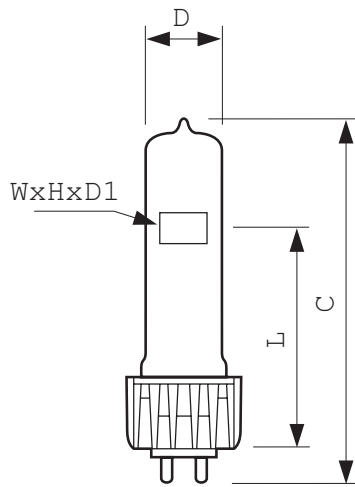

7007/LL 575W 230V 1CT

Product	C (Max)	D (Max)	D1 (Norm)	H (Norm)	L (Norm)	W (Norm)
7007/LL 575W Heat Sink 230V	104	19	7.5	11.5	60.3	8.6



© 2013 Koninklijke Philips Electronics N.V.
All rights reserved.

Specifications are subject to change without notice. Trademarks are the property of Koninklijke Philips Electronics N.V. or their respective owners.

www.philips.com/lighting

2013, January 20
data subject to change