

# robart HOW-TO Series Model Incidence Meter

The term "incidence" is something of a misnomer since this highly versatile tool is capable of measuring or comparing angles other than incidence of a wing or tail. As will be seen in the following diagrams, the Robart Incidence Meter can also be used for checking or setting the following angles.

- Fuselage leveling
- Wing leveling
- Wing incidence
- Stabilizer leveling
- Biplane decalage
- Engine thrust line
- Stabilizer incidence
- Engine side-thrust
- Wash-in or wash-out
- Fin offset
- Wheel axle Toe-in

## Reading The Robart Model Incidence Meter

The meter has two indicators on the front. The upper indicator is a sensitive, weighted pointer mounted in jewel bearings and is calibrated in degrees, while the lower indicator is a simple bubble level in a glass vial, whose only calibration consists of two lines on the front of the vial.

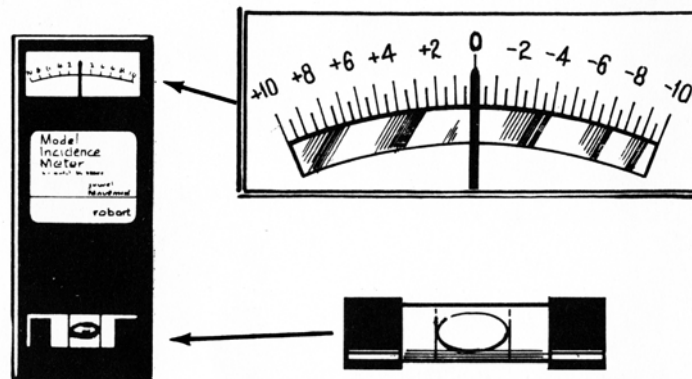

When the bubble is exactly centered between the two lines on the vial the incidence meter is considered leveled. The upper, magnified meter scale is provided with a mirror along its lower edge. To take an accurate reading the viewer must eliminate any chance of parallax error, and to achieve that the viewer should align the **reflection of the pointer** with the **actual pointer** so that the reflected image is totally hidden behind the pointer. Only after doing this should a reading is taken.

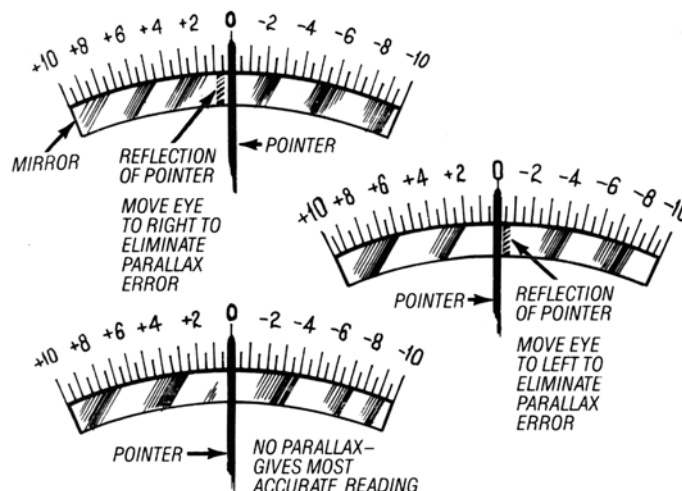

## Leveling The Fuselage

This operation invariably precedes all other operations. The fuselage should be solidly supported. Use a Robart Super Stand to secure & level the fuselage, with large rubber bands. Or set the axles on the bench, and place a suitable block under the rear fuselage. Then place the Robart Incidence Meter on some part of the structure known to be parallel to the aircraft datum (center line). Often the model's longeron or building crutch is parallel to the datum, but check the model plans to be sure. If a convenient structural member does not exist then measure and mark a datum on the fuselage and insert two pins, suitably spaced, then set the meter on those. Since the bottom of the fuselage usually slopes up to meet the tail, merely sliding the block back or forwards will raise or lower the tail. When the bubble level on the meter is centered between the lines on the glass vial the fuselage is now level. To prevent the fuselage being disturbed it is advisable to secure it to the bench with rubber bands looped around small nails in the bench or by placing weights on the fuselage. Telephone books or encyclopedias are a useful source on non-damaging weight. The sliding Vee blocks can be moved to fit between forms should it be necessary.

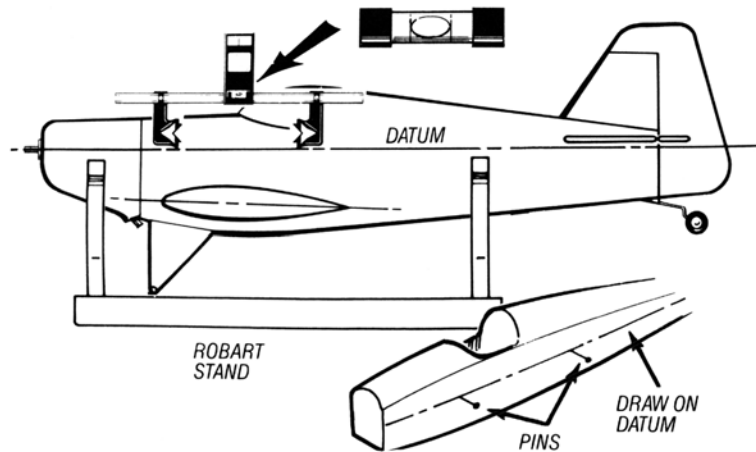

## Wing Incidence

1. Level the fuselage as described previously.
2. Set the Robart Incidence Meter on the wing as shown, sliding the Vee blocks inwards until they gently grip the leading and trailing edges. The amount of incidence present (i.e. the amount in degrees the leading edge is tilted up or down) is indicated by the pointer. See the proper wing incidence of your model according to the plans. Shim the wing saddle to achieve the correct wing incidence.

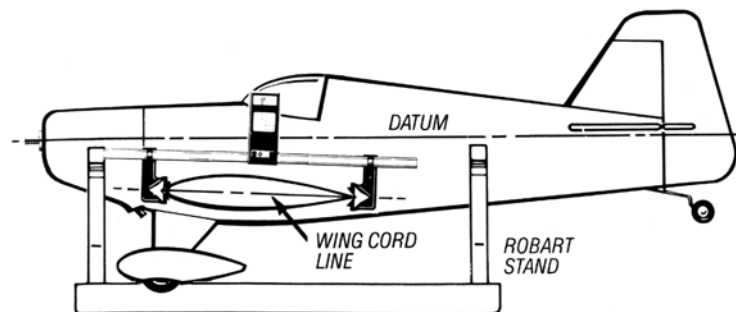

### Example:

- a.  $+2^\circ$  means that the wing has POSITIVE incidence, the leading edge of the wing being **higher** than the trailing edge.
- b.  $-2^\circ$  means that the wing has NEGATIVE incidence, the leading edge of the wing being **lower** than the trailing edge.

NOTE: The pivoting "Vee" blocks will automatically center the incidence meter on the wing chord line. The "Vee" blocks will also allow accurate positioning on tapered and elliptical wing plan forms.

## Biplane Decalage

The wing of a biplane-especially a sport or scale biplane-are usually set at differing angles of incidence and the difference between these two angles is known as the **DECALAGE ANGLE**.

1. Level the fuselage.
2. Set the Robart Incidence Meter on the **lower** wing, sliding the Vee blocks inwards until they gently grip the leading and trailing edges, then read off the incidence indicated by the pointer. Set the lower wing incidence according to the plans. Shim the wing saddle to achieve proper wing incidence. Record this reading.
3. Move the Robart Incidence Meter to the **upper** wing then read off the incidence. Set the proper wing incidence according to the plans. Shim the upper wing cradle for proper incidence. Record the value.

If the wings are set at the angles of incidence specified on the construction plan then all will be well but, if they are not, steps should be taken to rectify the matter. The **decalage** is determined by subtracting one reading from the other:

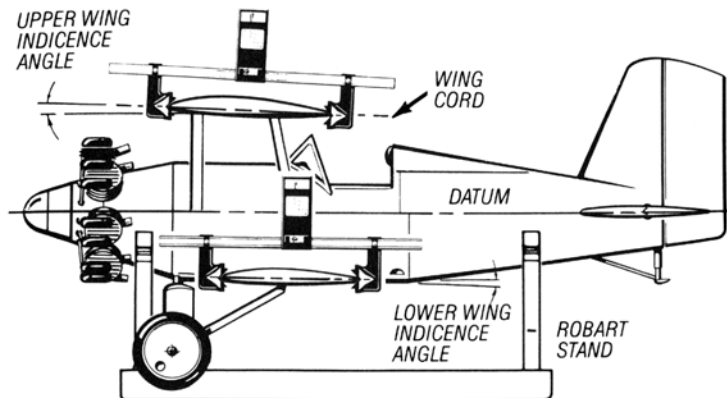

*Example:*

Upper wing +4°

Lower wing +1°

Subtract....  $4 - 1 = 3^\circ$  decalage

---

## Wash-In and Wash-out

For stability and better low speed handling characteristics many wings are built with a progressive twist from root to tip. Usually the tip leading edge is lower than the root leading edge and this is known as **wash-out**.

If your wing is discovered to have the reverse situation (i.e. the tip leading edge is higher than the root leading edge) you have wash-in, and in conventional airplanes this is undesirable and dangerous to the well-being of your model's flight.

Be aware that some types of models require neither wash-in nor wash-out, aerobatic models being a prime example. Review your plans to see what is specified.

1. Level the fuselage.
2. Set your Robart Incidence Meter on the wing root and adjust the Vee blocks to gently grip the leading and trailing edges. Read the incidence indicated by the pointer and record this reading.
3. Set the incidence meter on the wing tip, slide the Vee blocks inwards then read the incidence shown by the pointer. Record this reading.

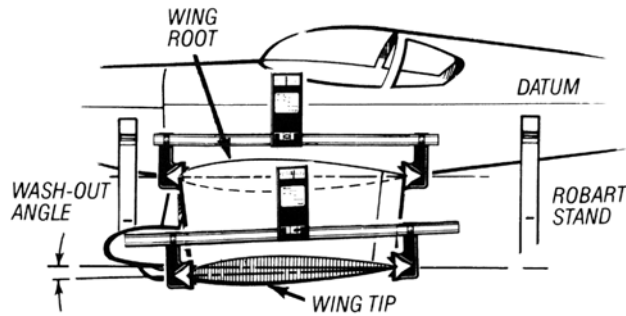

*Examples:*

Wing root Incidence  $+1^\circ$

Wing tip incidence  $-1^\circ$

Total wash-out angle

(or wing twist) is  $2^\circ$

Wing root incidence  $0^\circ$

Wing tip incidence  $-2^\circ$

Total wash-out angle

(or wing twist) is  $2^\circ$

NOTE: If your model has strip ailerons or the shorter "barn door" ailerons these must be locked in the neutral position before setting the incidence meter on the wing. See the instructions regarding the stabilizer incidence and cut a balsa template to slip over the wing to lock the ailerons in neutral.

## Stabilizer Incidence

The angle of incidence of a horizontal stabilizer is as equally important as that of the wing, the two working in unison to assure the stability of an airplane.

1. Level the fuselage.
2. Securely clamp the elevators in neutral. This is best done by cutting a balsa template and sliding it over the stabilizer as shown.
3. Set the Robart Incidence Meter on the stabilizer, sliding the Vee blocks inwards to gently grip the leading and trailing edges. Read the stabilizer incidence from the pointer. NOTE: **Positive** and **Negative** incidences are read exactly as for the wing incidence. Shim the stabilizer to set correct incidence according to the plans. Recheck with the incidence meter. Check for warps in the stab by reading the meter at the root and tips.

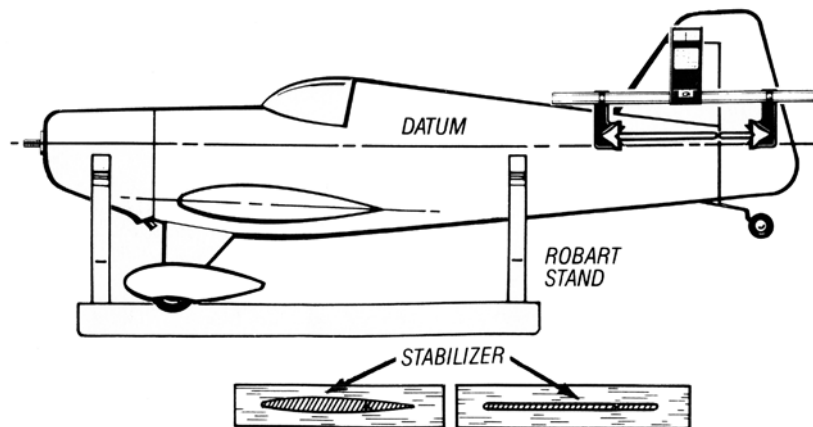

TYPICAL Balsa TEMPLATES TO LOCK ELEVATORS IN NEUTRAL

## Engine Thrust Line

The engine thrust line is not always set to point straight ahead. To achieve proper flight trim a designer will have determined by tests that a certain amount of **down-thrust** (even **up-thrust**) is required. Refer to your model plan for the information

1. Level the fuselage.
2. Use the propeller nut and drive washer to clamp one of the adjustable Vee blocks in place of the propeller. A thick wooden washer might be required to take up the space normally occupied by the propeller. Read the amount of down-thrust indicated by the pointer.

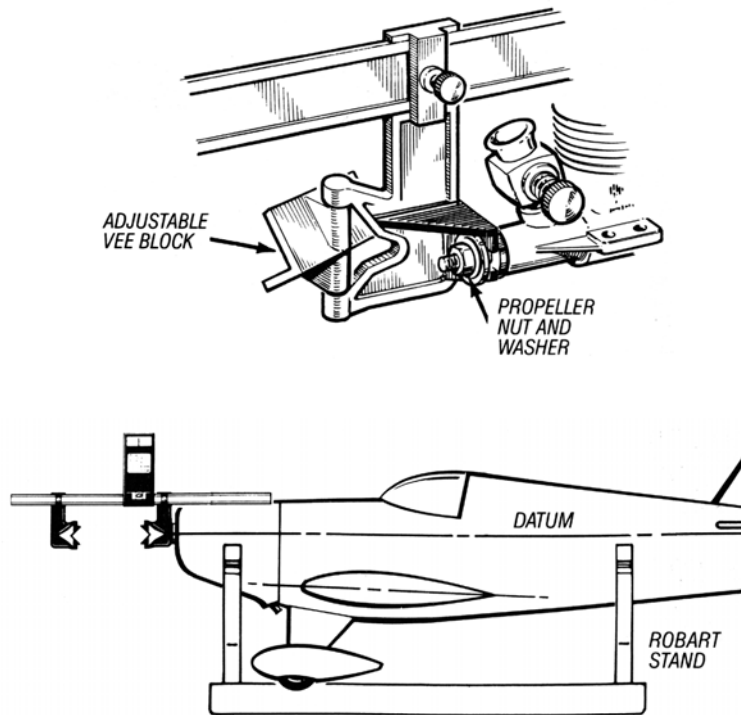

*Examples:*

-2° indicates 2° of **down-thrust**.

+2° indicates 2° of **up-thrust**.

Up-thrust is unusual... check your plan to see if this is required. If it is not, the problem should be rectified since this will make the model difficult to fly-even hazardous.

---

## Engine Side-Thrust

As in the case of down-thrust, many models require **side-thrust** to achieve proper flight trim. Check your model plans to see if this is required. Very often it is **right** side-thrust that is specified.

1. Turn the fuselage on its side as illustrated.
2. Level the fuselage on the datum line and secure it firmly to prevent further movement.
3. Bolt one adjustable Vee block to the propeller shaft as detailed previously. Now read the thrust line offset from the pointer. As shown in the illustration, a reading of +2° indicates a **right** side-thrust of that amount.

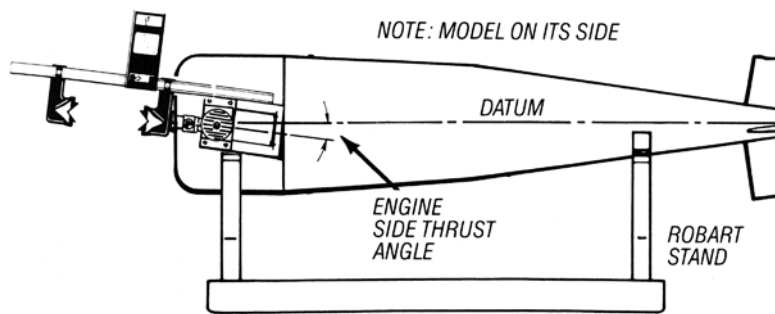

## Stabilizer Leveling

It is not generally realized by many modelers that if the horizontal stabilizer is tilted to the left or right the end result in flight is a very definite tendency for the model to turn. Correct use of your Robart Incidence Meter will ensure that the stabilizer is horizontal.

1. Level the fuselage. If the landing gear is already attached, then support the fuselage on a suitable block. Use a Right Triangle or a Carpenters Square to ensure that the fuselage center line is vertical, placing thin shims under either side to achieve this.
2. Set the stabilizer on its fuselage seating and place the Robart Incidence Meter across it as shown and check the bubble level and pointer to see that the stabilizer is horizontal. If all is well the stabilizer can be glued in place, leveling the meter in position while the glue sets. Periodically check the gauge to see that the stabilizer has not moved out of position.

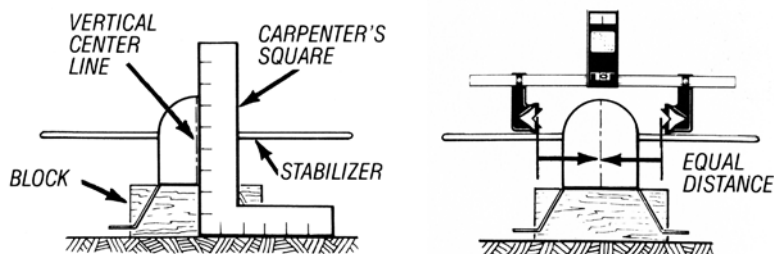

## Wing Leveling

If the wings of a model are not at  $90^\circ$  to the vertical datum (or center line) this fault, like a tilted stabilizer, will result in a tendency for the model to make unwanted turns in the direction of the tilt. Assuming the stabilizer has been leveled and glued in place you now have a convenient horizontal datum line from which to work.

1. Level the fuselage and stabilizer.
2. Set the Robart Incidence Meter across the wing as shown. NOTE: The adjustable Vee blocks **MUST** contact the wing on a line at  $90^\circ$  to the fuselage fore and aft center line and they must also be equidistant from the fuselage center line as illustrated. Check the position of the pointer and the bubble level. If the wings are **not** level the wing seating must be adjusted, by shims or sanding, to bring the wings level and the meter reading to  $0^\circ$ .

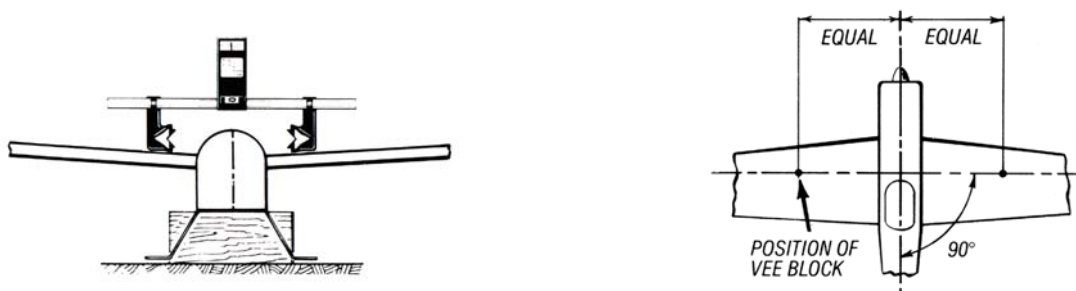

## Fin Offset

Some scale models follow their full size counterpart and require a fin offset to the left or right, check your plans for this information. NOTE: It will be necessary to clamp the rudder in neutral before commencing. See how to do this as described in Stabilizer Incidence.

1. Turn the fuselage on its side.
2. Level the fuselage as described above.
3. Attach the Robart Incidence Meter to the fin and rudder, sliding the Vee blocks inwards to lightly grip the leading and trailing edges. Read the offset indicated by the pointer.

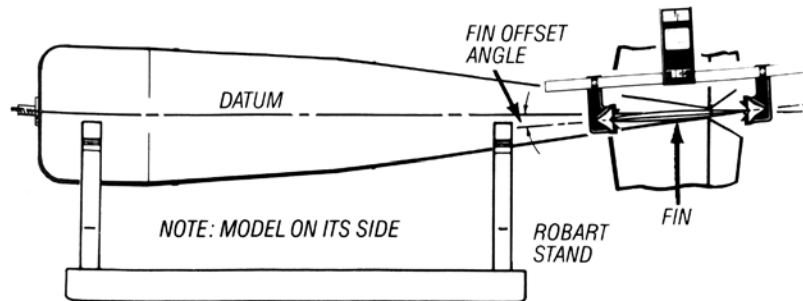

Examples:

-2° indicates the fin leading edge is offset to the left as illustrated.

+2° indicates the fin leading edge is offset to the right.

---

## Conclusion

Having followed these steps above on setting up your models incidence, rest assured that the moment of lift off will be straight and true. Building with the Robart Model Incidence Meter makes flying fun! You will know what to expect from your model from first flight, every flight-straight, true flying performance! Build & Fly like a pro-use the Robart Incidence Meter.