

PARTS LIST

ITEM	B/P NO	NO. REQD	NAME	MATERIAL
1	TC2143	1	PUMP HEAD	316 SS
2	TA2456	1	DISCHARGE BUSHING	303 SS
3	TA2455	1	SUCTION BUSHING	303 SS
4	TB0695	1	DISCHARGE CHECK VALVE SEAT	303 SS
5	TB0698	1	SUCTION CHECK VALVE SEAT	303 SS
6	TA0054	1	DISCHARGE CHECK BALL	316 SS
7	TA0053	1	SUCTION CHECK BALL	316 SS
8	TA0077	1	CHECK BALL SPRING	316 SS
9	TA2350	3	PLAN GASKET	304 SS
10	TA0444	1	BALL GAGE	17-4PH
11	-	1	SET PACKING	AS SPECIFIED
12	TA0043	1	PACKING GLAND	303 SS
13	TA0047	1	PACKING GLAND NUT	303 SS
14	TA6460	1	PLUNGER	17-4PH SS
15	TB0368	1	DISCHARGE CHECK SEAT ASSEMBLY	AS SPECIFIED
16	TB0698	1	SUCTION CHECK SEAT ASSEMBLY	AS SPECIFIED
17	TA0123	1	BLEEDER VALVE ASSEMBLY	AS SPECIFIED
18	-	1	O-RING	AS SPECIFIED
19	-	1	O-RING	AS SPECIFIED
20	TA2338	1	GASKET	304 SS

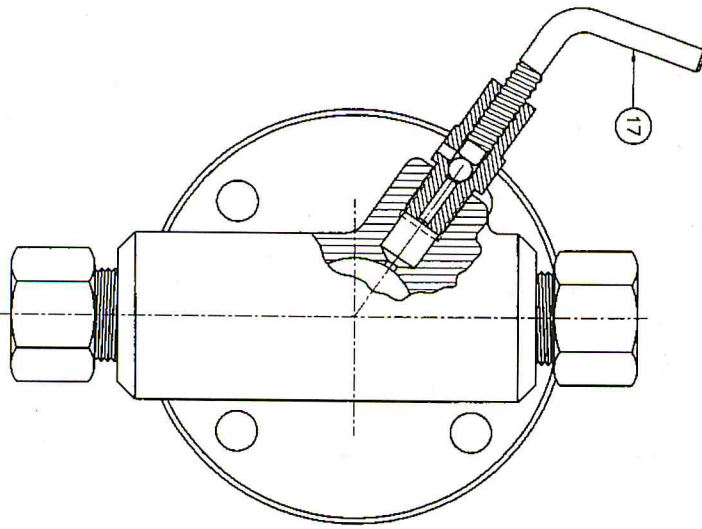
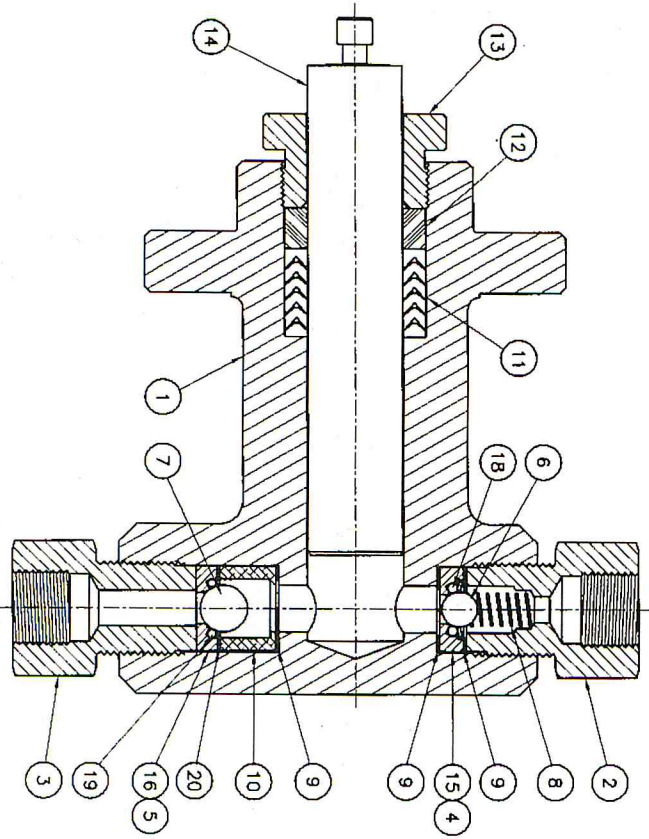

REMOVE BURRS & BREAK EDGES .015 MAX.

SCALE 1=1

QUALITY ASSURANCE AND ENGINEERING DIVISIONS FOR THE COMPANY, REPAIR AND MAINTENANCE OF EQUIPMENT, AND SHALL NOT BE USED, REPRODUCED OR ALTERED WITHOUT THE WRITTEN PERMISSION OF THE COMPANY.



1" - FLUID END ASSEMBLY
MX-5 & 2400 PUMP

DESIGNED	DATE	REV	DESCRIPTION
CHECKED	DATE		
APPROVED	DATE		



ALL DIMENSIONS ARE TO
MATERIAL UNLESS SPECIFIED
OTHERWISE.

INITIAL RELEASE
N/A
RFR
1/17/01
REVISIONS
DATE

TC2147

