



# series 6100

## GAS OR AIR DRIVEN RECIPROCATING PUMPS



### SPECIFICATIONS

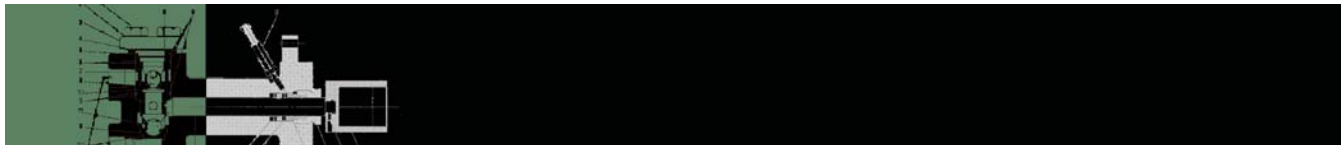
The TXT 6100 Series Pump line consists of a series of basic pump options all developed from a modular power unit. All units are pneumatically driven positive displacement, single or double acting, reciprocating pumps.

The basic pump is designed for use with three fluid ends, a 1-1/4" and 2-3/4" diameter plunger and a 4" diameter piston. The fluid ends are interchangeable with the modular power cylinder and can be assembled as single ended units or double ended units in all combinations of sizes. All fluid ends are designed to withstand maximum output force of the power cylinder.

Due to the balanced valving of the power cylinder it is, in theory, possible to operate the pump against a back pressure equal to the inlet power gas pressure; however, a differential in these two pressures must be maintained for the pump to stroke. (See Power to Fluid Ratio below) When the supply gas is piped off to other areas, the pilot valves may also be connected to the pump exhaust manifold system. All fluid ends are designed with removable cartridge type ball check valves. These valves may be replaced without disconnecting the suction and discharge piping.

### OPERATIONAL DATA

	1-1/4"	2-3/4"	4"
Pump Model Number	6111	6121	6141
Fluid Discharge Pressure Maximum	9000PSI	1800PSI	900PSI
Fluid Discharge Volumes up to Maximum Pressure	See Chart Pg. 6	See Chart Pg. 7	See Chart Pg. 8
Operating Speed Maximum	See Chart Pg. 6	See Chart Pg. 7	See Chart Pg. 8
Minimum	See Chart Pg. 6	See Chart Pg. 7	See Chart Pg. 8
Power/Fluid Pressure Ratio	40:1	8:1	4:1
(Inlet Gas Pressure - Exhaust Back Pressure) X Power to Fluid Ratio = Maximum Fluid Discharge Pressure at Stall			
Pneumatic Pressure Required to Operate Pump	See Chart Pg. 6	See Chart Pg. 7	See Chart Pg. 8
Maximum Temperature	200°F with Buna-N trim, all models		
	400°F with Viton trim, all models		
Minimum NPSHR	8ft. of water, all models		



## INSTALLATION AND OPERATING INSTRUCTIONS

1. Remove pump from shipping container and inspect for possible shipping damage. If damaged, file claim with carrier.
2. Mount pump by bolting to a stable foundation. Four lugs are supplied on the power unit for this purpose.
3. Connect fluid suction and discharge lines. Caution should be exercised to avoid imparting piping stresses to the fluid head of the pump. A relief valve should be installed in the discharge line between the discharge check valve and the nearest shut off valve or auxiliary check valve.

### CAUTION:

**When pump is installed in a closed or hazardous area, power gas exhaust (including pilot devices) must be vented in a safe manner. All gas connections must be checked periodically for leaks. If power gas or air supply pressure exceeds 250 psig, a regulator and pressure relief valve of proper size must be installed.**

4. Connect power supply lines as shown in Figure 1. Power supply pressure must not exceed 250 PSIG.\*
5. Fill lubricator reservoir with 1 quart SAE 10, SAE 20 or SAE 30 non-detergent oil dependent upon operating temperature.
6. For connections where it is necessary to pipe off exhaust gas such as back pressure service or

pollution control, refer to Figure 3. Order Exhaust Manifold TB-1126 and make all connections shown in Figure 3.

7. Open supply line slowly in order to check pump and system operation,
8. Adjust supply volume and pressure to regulate operating speed to meet desired conditions of discharge pressure and volume.
9. Adjust lubricator to minimum supply rate.
10. On 6111 pumps maintain plunger lubrication by adjusting grease jack periodically.

\* For safe operation, a safety valve sized to meet the maximum capacity of the supply source should be installed in the supply line at or near the pump.

## WEIGHTS & DIMENSIONS

(pounds) (inches)

Model #	A	B	C	D	E	F	WT.
6111	40-1/4		8-5/8	4-11/16	3/4	3/4	260
6112		61-1/4	8-5/8	4-11/16	3/4	3/4	340
6121	40-1/4		9-5/16	4-1/4	1	1	268
6122		61-1/4	9-5/16	4-1/4	1	1	362
6141	42-1/2		9-23/32	3-5/8	2	2	300
6142		65-5/8	9-23/32	3-5/8	2	2	428

## MATERIAL SPECIFICATIONS

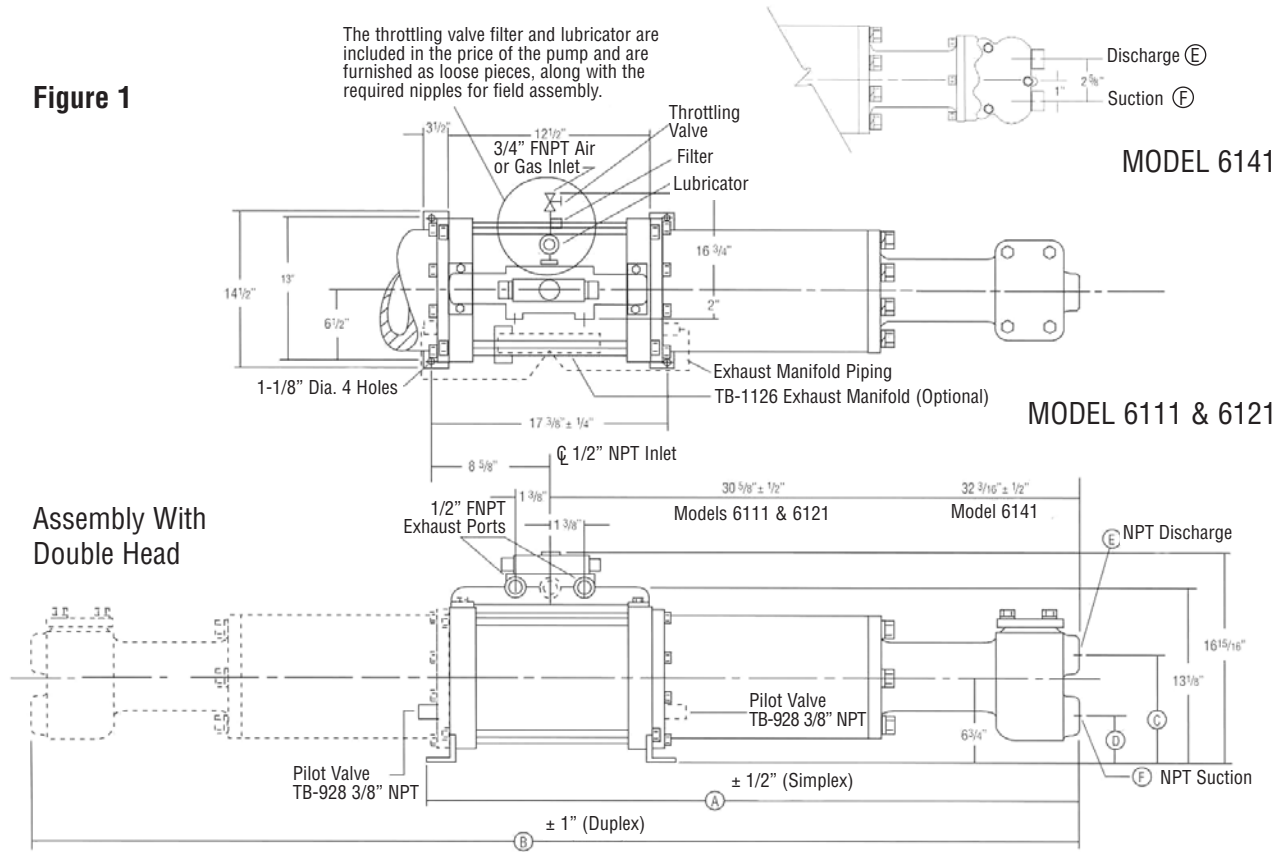
Power End (All Models)		Fluid End - Models 6111, 6112, 6121, & 6122		Fluid End - Models 6141 & 6142	
Main Power Cylinder	Carbon Steel	Pump Head Body	Cast Steel (316 SS optional)	Pump Head Body	Cast Steel (316 SS optional)
Power Cylinder End Caps	Carbon Steel	Valve Cover	Carbon Steel	Valve Cover	Carbon Steel
Power Piston	Aluminum	Valve Plug	Stainless Steel	Valve Plug	Stainless Steel
Power Piston Seals	Buna-N	Plunger	Stainless Steel	Valve Spring	Stainless Steel
Power Cylinder Seals	Buna-N	Valve Ball	Stainless Steel	Valve Ball	Stainless Steel
Power Piston Rod	Stainless Steel	Valve Seat Insert	Stainless Steel	Valve Seat Insert	Stainless Steel
Piston Rod Packing Gland	Carbon Steel	Valve Seat Gasket	Teflon	Valve Seat Gasket	Teflon
Piston Rod Packing	Optional	Valve Seat Seals	Buna-N	Piston	Carbon Steel
		Packing	Optional	Piston Cup	Optional
		Lantern Ring	Stainless Steel	Piston Rod	Stainless Steel
		Packing Gland	Delrin	Cylinder	Cast Ductile Iron
		Packing Nut	Carbon Steel	Cylinder Sleeve	Stainless Steel

# GAS OR AIR DRIVEN RECIPROCATING PUMPS

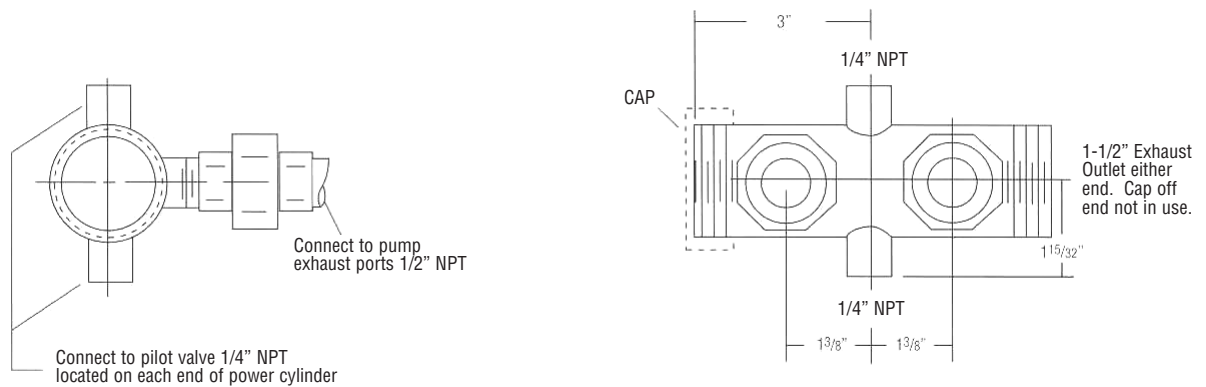
series **6100**

## DIMENSIONAL DATA

**Figure 1**

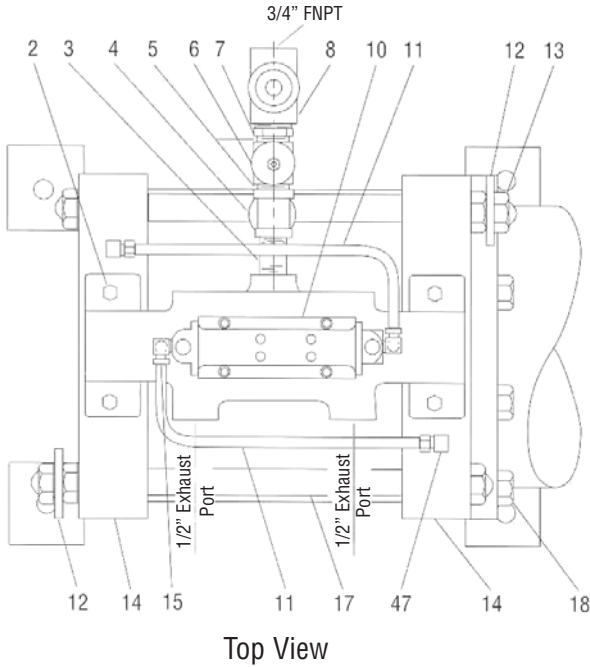


**Figure 3 - Exhaust Manifold TB-1126 (optional)**

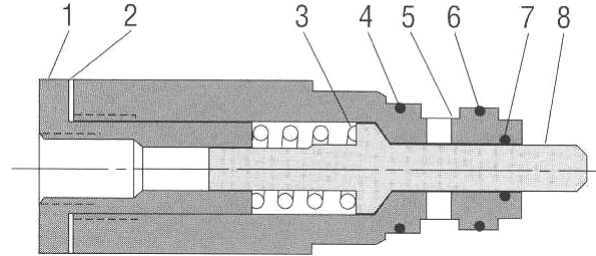




## POWER UNIT (TD-365)



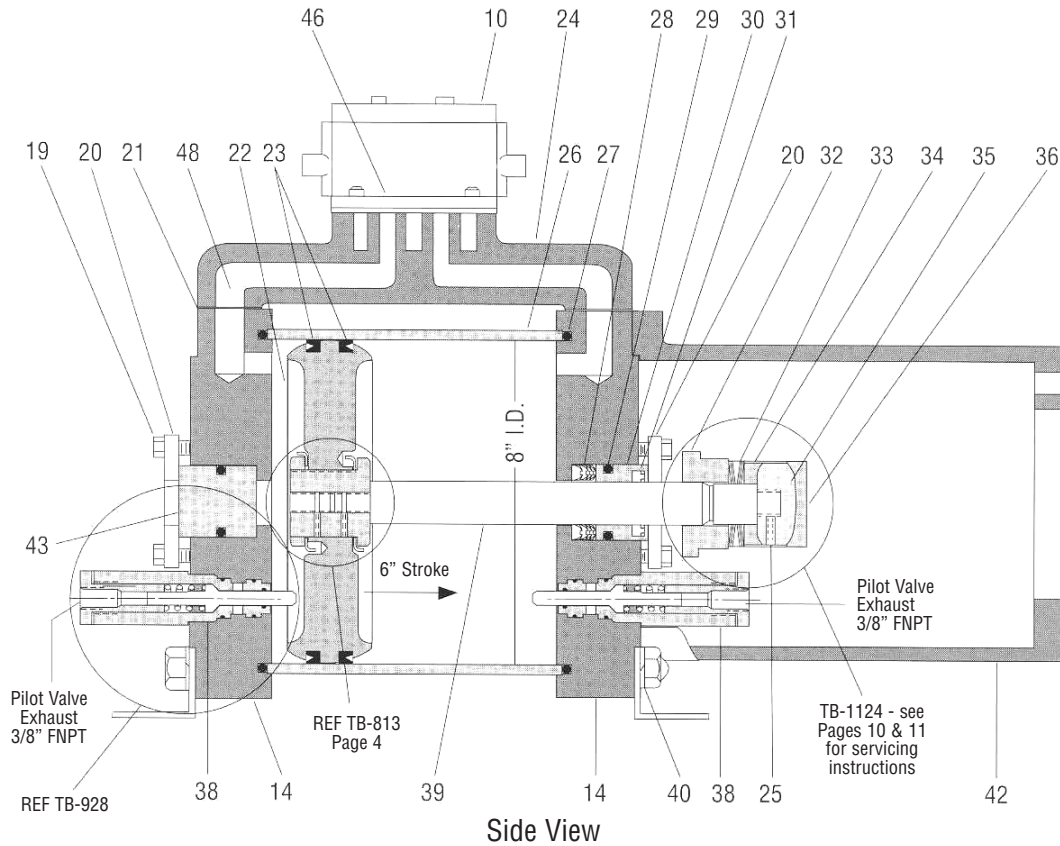
### Pilot Valve TB-928



(See Servicing Instructions - Page 9)

TB-928 Pilot Valve (Two Required)				
Item	B/P No.	No. Reqd.	Name	Material
1	TA-2901	1	Sleeve Adapter	Stainless
2*	TA-3024	1	Gasket	Accopac
3	TA-1053	1	Spring	Steel
4*	TA-3219	1	O-Ring	Buna-N
5	TA-817	1	Sleeve	Steel
6*	TA-3212	1	O-Ring	Buna-N
7*	TA-612	1	O-Ring	Buna-N
8	TA-2805	1	Plunger	Delrin

\* Recommended Spare Parts

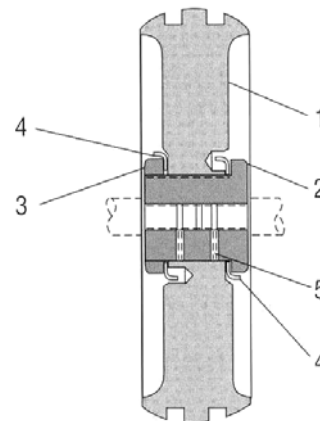


# GAS OR AIR DRIVEN RECIPROCATING PUMPS

series **6100**

## PARTS LIST

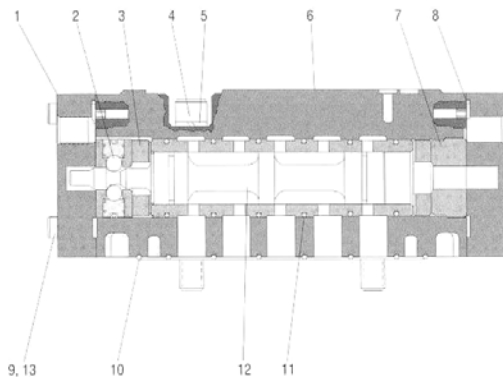
Item	B/P No.	No. Reqd.	Name	Material
2	61283PO19	4	Hex Head Capscrew	Steel
3	TA-3241	1	Nipple	Steel
4	TA-3221	1	Lubricator (1 Quart Capacity)	Aluminum
5	TA-3242	2	Nipple	Steel
6	TA-3220	1	Filter	Aluminum
7	TA-3243	1	Hex Bushing	Steel
8	TA-3209	1	Capacity Control Ball Valve 3/4"	Carbon Steel
10	TA-1510	1	Spool Valve Assy.	Various
11	TA-5690	2	Line	304 SS
12	TA-2839	2	Lifting Eye	Steel
13	TA-2807	2	Jam Nut	Steel
14	TC-533	2	End Cap	Steel
15	TA-3364	2	90° Male Elbow	Cad. Pl. Stl.
17	TA-4451	4	Stud & Nut Assy.	Steel/ Teflon Coated
■ 18	TA-2521	8	Hex Head Capscrew	Steel
19	TA-163	8	Hex Head Capscrew	Steel
20	TA-2781	2	Packing Plate	Steel
21	TA-2898	2	Gasket	Buna-N & Cork
22*	TB-813	1	Power Piston Assy.	Aluminum
23*	TA-3761	2	Piston Seals	Buna-N
24	TC-370	1	Manifold	Ductile Iron
■ 25	TA-3250	1	Set Screw	304 SS
26	TB-815	1	Power Cylinder	Steel
27*	TA-2859	2	O-Ring	Buna-N
■ 28*	TA-2860	1	Power Rod Packing	Buna-N
29*	TA-1962	2	O-Ring	Buna-N
■ 30	TA-2786	1	Gland Bushing	Cast Iron
■ 31*	TA-2897	1	Wiper Ring	Buna-N
■ 32	TA-2803	1	Retainer	Steel
■ 33*	TA-2854	4	Bellville Washer	Steel
■ 34	TA-2783	1	Back-up Ring	Steel
■ 35	TA-2782	1	Ball Bearing Conn.	Carbon Steel
■ 36	TA-2787	1	Thrust Bearing	Carbon Steel
38	TB-928	2	Pilot Valve	See Pg. 4
■ 39*	TB-810	1	Power Piston Rod	17-4 PH SS
40	TA-2813	8	Lock Washer	Steel
■ 42	TD-310	1	Spacer	Ductile Iron
● 43	TA-2830	1	End Plug	Cast Iron
44	TA-171	2	Pin (not shown)	Brass
45	GA-3183	1	Name Plate (not shown)	Stainless Steel
46	TA-4082	1	Adapter Assembly	Aluminum
47	TA-3244	2	90° Male Elbow	Cad. Pl. Steel
48	TA-4517	2	Wire Screen Filter	304 SS



(See Servicing Instructions - Page 9)

**TB-813 Power Piston (Item 22, Page 4)**

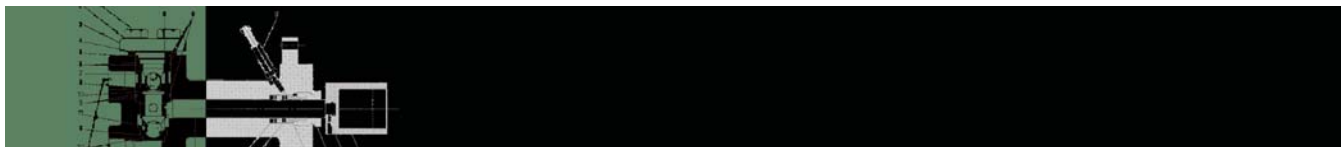
Item	B/P No.	No. Reqd.	Name	Material
1	TC-789	1	Piston	Aluminum
2	TB-1125	1	Bushing	Steel
3	TA-3760	1	Bushing Nut	Steel
4	TA-3759	1	Locking Ring	Steel
5	TA-3762	1-Simplex 2-Duplex	Set Screw	Steel



**TB-1510 Spool Valve**

Item No.	Reqd.	Part Name
1	2	End Cap
2	1	Detent Assembly
3	2	Bumper
4	4	Screw
5	4	Lock Washer
6	1	Body Assembly
7	1	Bumper
8	2	O-Ring
9	8	Screw
10	1	Gasket
11	6	O-Ring Seal
12	1	Sleeve Assembly
13	8	Lock Washer

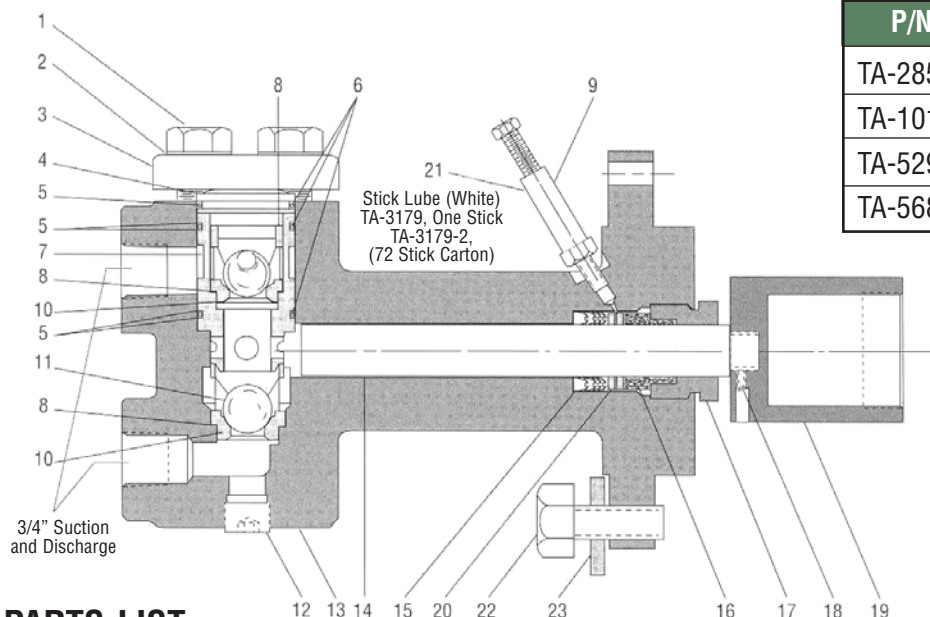
NOTES:  
 \* Recommended Parts  
 ■ Two parts or sets required on double head configurations  
 ● Required only on single head configurations



## MODELS 6111 & 6112

### 1-1/4" HIGH PRESSURE PUMP HEAD ASSEMBLY

(P/N TD-0318 Cast Steel) (P/N TD-1980 316 SS)



Packing Chart – 1-1/4

P/N	Material	Max. W.P.#
TA-2850	Buna-N	3000
TA-1014	Teflon	500
TA-5290	Viton	3000
TA-5689	Hard	9000

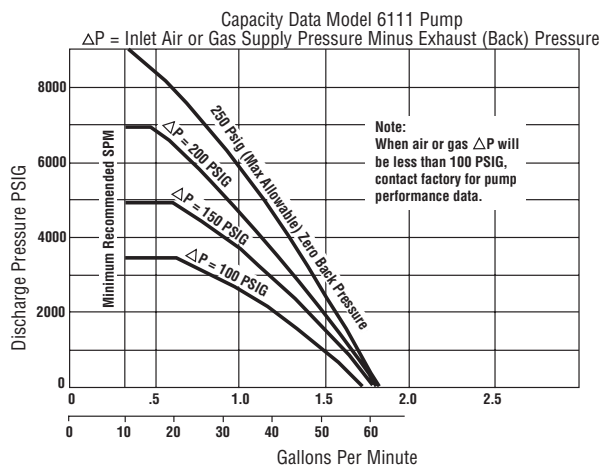
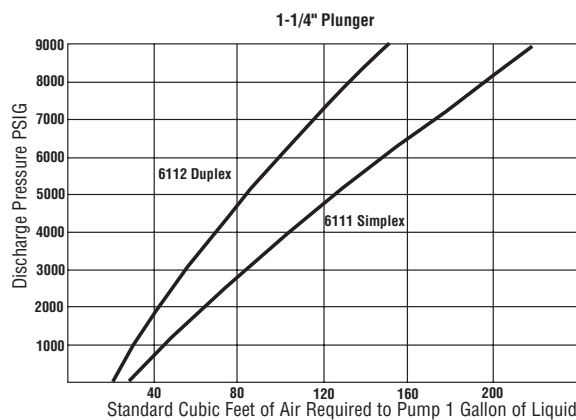
### PARTS LIST

Item	B/P No.	No. Reqd.	Name	Material
1	TA-2868	4	Hex Head Capscrew	Cad. Pl. Stl.
2	TA-2756	4	Washer	Cad. Pl. Stl.
3	TB-816	1	Cover	Steel
4	TA-2849	1	Valve Plug	Stainless Steel
5*	TA-2852	5	Back-up Ring	Teflon
6*	TA-2856	3	O-Ring	Buna-N
7	TB-812	1	Spacer	316 SS
8*	61421P004	3	Gasket	Teflon
9	TA-558	1	Grease Jack	Steel
10*	61437P023	2	Valve Seat Insert	316 SS
11*	61265P041	2	Valve Ball 7/8" Dia.	440C SS
12	HA-2152	1	Pipe Plug	Steel
13	TD-500	1	Pump Head Body	Cast Steel
	TD-502	1	Pump Head Body	316 SS
14*	TB-811	1	Plunger	17.4PH SS
15*	See Chart Above	1	Packing	See Chart Above
16	TA-2788	1	Packing Gland	Delrin
17	TA-2789	1	Packing Nut	Steel
18	TA-3250	1	Set Screw (S.H.)	303 SS
19	TA-2780	1	Ball Cup Conn.	Steel
20	TA-2855	1	Lantern Ring	304 SS
21*	TA-3179	1	Stick Lube	
	TA-3179-2	72	Stick Carton	
22**	TA-3239	6	Cap Screw	Cad. Pl. Stl.
23**	TA-3060	6	Lock Washer	Cad. Pl. Stl.

TA-4479  
Viton

TA-4481  
Ryton TFE

Air Consumption Models 6111 & 6112 (Zero Back Pressure)



Strokes Per Minute (6" Stroke Length - 0.0287 Gallons Per Stroke)

\* Recommended Spare Parts  
\*\* Not Included in Head Assemblies

# GAS OR AIR DRIVEN RECIPROCATING PUMPS

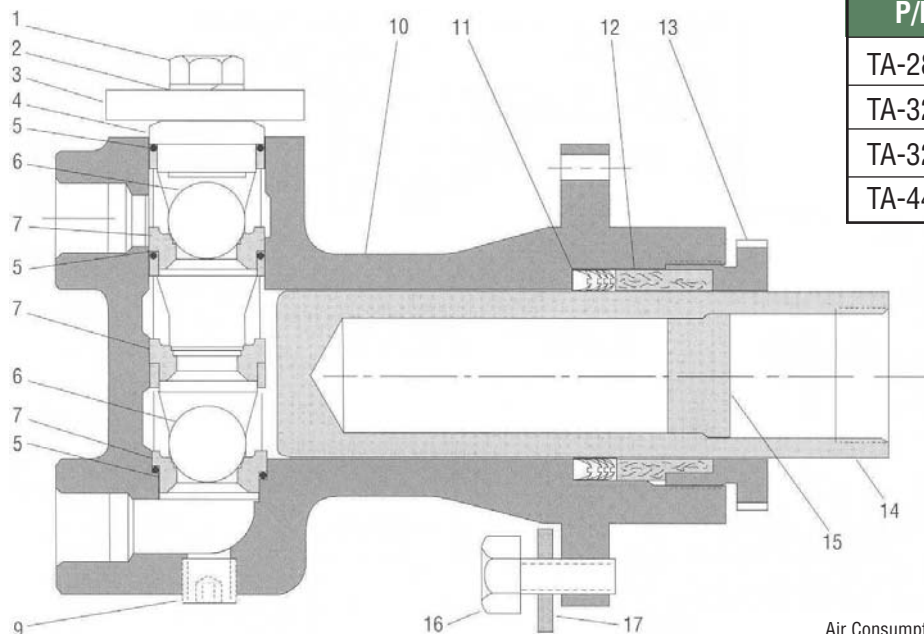
series

# 6100

## MODELS 6121 & 6122

### 2-3/4" PUMP HEAD ASSEMBLY

(P/N TD-0314 Cast Steel) (P/N TD-1979 316 SS)



Packing Chart – 2-3/4"

P/N	Material	Max. W.P.#
TA-2861	Buna-N	1800
TA-3294	Teflon	1800
TA-3296	TFE Buna	1800
TA-4456	Viton	1800

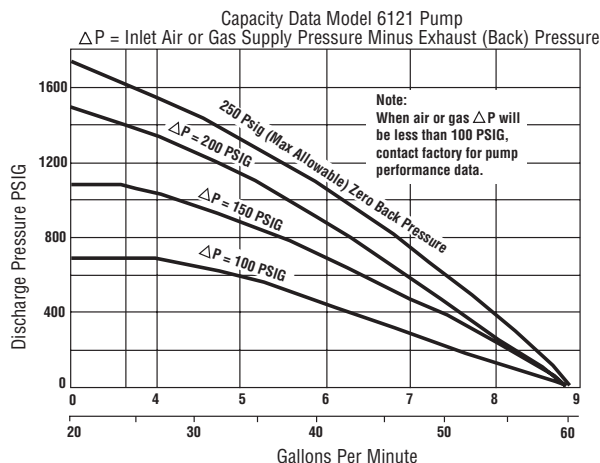
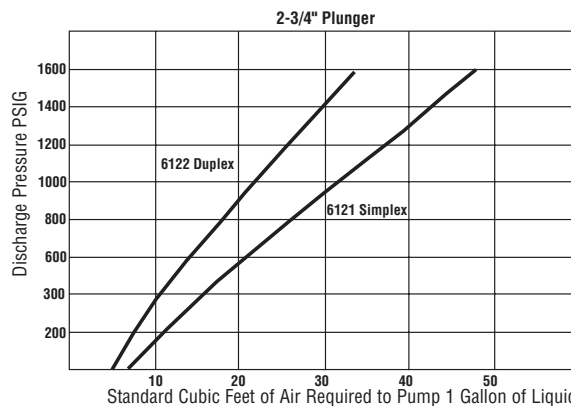
## PARTS LIST

Item	B/P No.	No. Reqd.	Name	Material
1	TA-2868	2	Hex Head Capscrew	Cad. Pl. Stl.
2	TA-2756	2	Washer	Cad. Pl. Stl.
3	TA-2800	1	Cover	Steel
4	TA-3213	1	Valve Plug	Stainless Steel
5*	TA-3853	3	O-Ring	Buna-N
6*	61265P061	2	Valve Ball 1-1/4" Dia.	440C SS
7*	TB-1022	3	Valve Seat Insert	316 SS
9	TA-3299	1	Pipe Plug	Steel
10	TD-501	1	Pump Head Body	Cast Steel
	TD-503	1	Pump Head Body	316 SS
11*	See Chart Above	1	Packing	See Chart Above
12	TA-2784	1	Packing Gland	Delrin
13	TB-809	1	Packing Nut	Steel
14*	TB-808	1	Plunger	17-4 PH SS
15	TA-2785	1	Thrust Plate	Steel
16**	TA-3239	6	Cap Screw	Cad. Pl. Stl.
17**	TA-3060	6	Lock Washer	Cad. Pl. Stl.

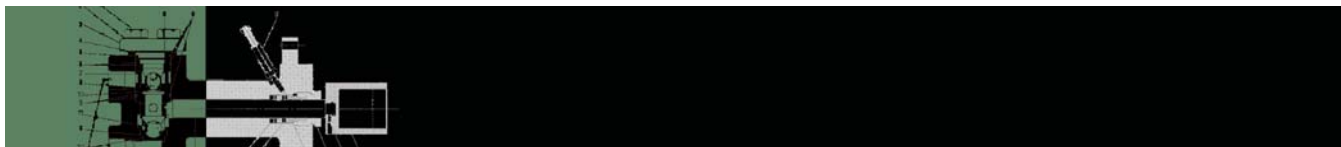
\* Recommended Spare Parts

\*\* Not Included in Head Assemblies

Air Consumption Models 6121 & 6122 (Zero Back Pressure)



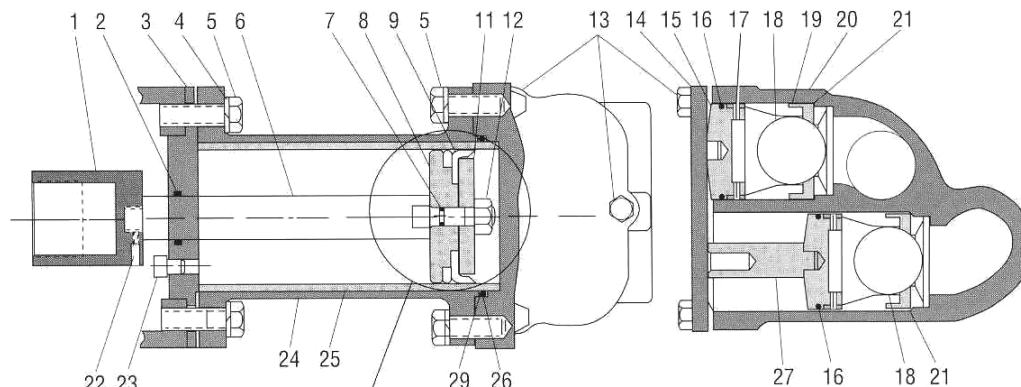
Strokes Per Minute (6" Stroke Length - 0.14 Gallons Per Stroke)



## MODELS 6141 & 6142

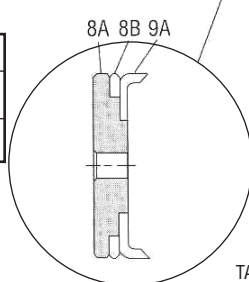
### 4" PUMP HEAD ASSEMBLY

(P/N TD-0348 Cast Steel) (P/N TD-0507 316 SS)



Alternate Piston Assembly With Special Trim

8A	TB-1211	Piston CS
8B	TB-1210	Wear Ring Teflon
9A	TA-4384	Piston Cup Viton

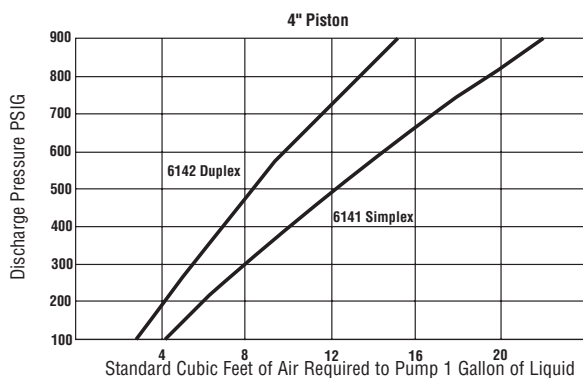


## PARTS LIST

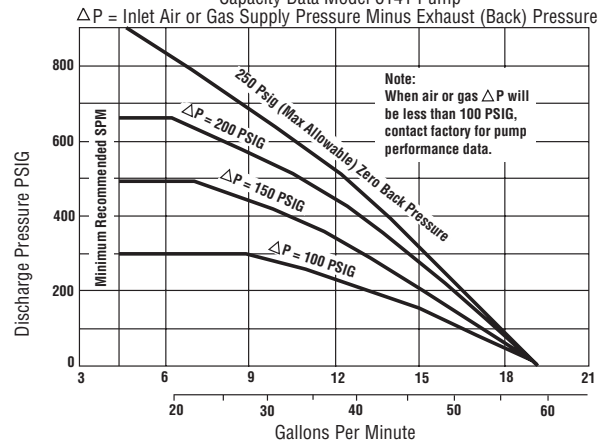
Item	B/P No.	No. Reqd.	Name	Material
1	TA-2780	1	Connector Cup	Steel
2*	TA-2897	1	Wiper Ring	Buna-N
3	TB-856	1	End Plug	Steel
4	TA-3060	12	Lock Washer	Cad. Pl. Stl.
5	TA-3239	12	Hex Head Screw	Cad. Pl. Stl.
6*	TB-854	1	Piston Rod	17-4 PH SS
7*	TA-3226	1	O-Ring	Buna-N
8	TB-857	1	Piston	Carbon Steel
9*	TA-3202	1	Piston Cup	Buna-N
11	TA-3248	1	Backup Retainer	304 SS
12	TA-3246	1	Hex Nut	Cad. Pl. Stl.
13	TA-3245	3	Hex Head Screw	Cad. Pl. Stl.
14	TB-855	1	Cover	Steel
15	TA-3490	2	Valve Plug	316 SS
16*	TA-2104	2	O-Ring	Buna-N
17	TA-3514	4	Roll Pin	Steel
18*	61265P071	2	Valve Ball 2" Dia.	440-CC SS
19*	TB-1023	2	Valve Seat Insert	316 SS
20	TD-504	1	Pump Head Body	Cast Steel
	TD-506	1	Pump Head Body	316 SS
21*	61421P006	2	Gasket	Teflon
22	TA-3250	1	Set Screw	304 SS
23	TA-1835	1	Breather	Assembly
24	TC-390	1	Cylinder	Cast Ductile Iron
25*	TB-950	1	Sleeve	304 SS
26*	TA-3218	1	O-Ring	Buna-N
27	TA-3051	1	Plug Extension	303 SS
29*	TA-2148	1	Back-up Ring	Buna-N

\* Recommended Spare Parts  
 \*\* Not Included in Head Assemblies

Air Consumption Models 6141 & 6142 (Zero Back Pressure)



Capacity Data Model 6141 Pump



Strokes Per Minute (6" Stroke Length - 0.29 Gallons Per Stroke)



**GAS OR AIR DRIVEN RECIPROCATING PUMPS** series**6100****SERVICING INSTRUCTIONS****Power End, page 4****CAUTION:**

**Prior to performing any maintenance on the power or fluid end of this pump, all pneumatic and hydraulic pressure must be removed and isolated from the unit.**

**TB15 10 (page 5) valve is a 2-position, 4-way spool valve with internal parts for bleeder pilot operation.**

**To inspect, proceed as follows:**

1. Remove 4 allen head cap screws #9 from pilot end caps.
2. Remove pilot end cap. (One end cap contains the detent body springs and balls.)
3. Remove bumper #7,
4. Remove spool and examine.
5. If required, the sleeve assembly #11 can be removed; however, this assembly contains the static o-ring seals and may be difficult to reassemble.
6. To remove valve from pump, loosen 4 cap screws.

**NOTE:**

**When reassembling, extreme care must be exercised to eliminate damage to the static o-rings, contamination on the sleeve and/or spool and to protect end gaskets.**

**REF: TD-365, page 4**

Item #11 Control Lines-All connections must be tight and leak free.

Item #24 Manifold must be securely fastened at both end cap connections and to the spool valve. When reassembling to the end caps, care should be taken to correctly position gaskets to preclude partial blockage to the pneumatic ports.

Pilot valve assembly may be removed from the power end cap #14 as a unit. In reassembling this unit, care must be exercised to protect O-ring seals as leakage in this area will cause unit to short stroke or make unit entirely inoperative.

**Disassembly of Pilot Valve may be done as follows: (REF: TB-928), page 4, item 38**

1. Remove adapter #1 from sleeve #5.
2. Remove spring #3 and examine for set and stress failure.

3. Remove plunger #5 and examine angled seat face and O.D. surface of probe end. Probe end must be smooth enough to affect a pneumatic seal with O-ring #7.
4. Examine all O-rings and replace if necessary.

**Disconnect Fluid Head from Power Cylinder (REF: TB-1124), page 4**

1. Position pump in discharge position if possible.
2. Remove retainer #32 from cup (this is a right hand thread).
3. Slowly apply power gas to withdraw power piston rod #39 from cup. If pump does not operate this connection may be pried apart.

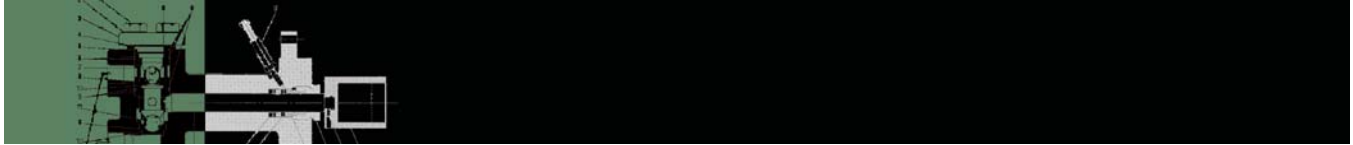
**Disassembly of Power Cylinder**

**(REF: Power Unit Assembly TD-365), page 4**

1. Loosen set screw #25 and remove connector bearing ball #35 from end of rod #39
2. Remove back-up ring #34, Belleville washers #33 and retaining nut #32.
3. Remove 4 hex head screws #19 and packing plate #20.
4. Disconnect both pilot control lines #11 and #16.
5. Remove 4 manifold bolts #2. At this point, the valve and manifold assembly may be removed from the power cylinder.
6. Remove tie down bolts.
7. Remove hex nuts #1 from one end of each tie rod #17.
8. Remove end caps #14 from cylinder #26.
9. Remove piston #22 and power piston rod #39 from cylinder #26.

**Disassembly of Power Piston (REF: TB-813), page 5**

1. Bend down tab on both locking rings #4.
2. Remove bushing nut #3 from bushing #2.
3. Remove bushing #2 (with piston rod attached) from piston #5.
4. Remove set screw #5 from bushing #2.
5. Remove power piston rod from bushing #2.



### Assembly of Power Piston cont'd (REF: TB-813), page 5

1. Install TB-810 power piston rod/rods into bushing #2 using Locktite #242 and tighten securely.
2. Install set screw/screws #5 using Locktite #242 and tighten firmly against power piston rod/rods.
3. Bend one (1) tab on each of two (2) locking rings #4, 90° to the plane of the ring.
4. Place one (1) locking ring #4 over bushing #2 (bent tab positioned away from bushing shoulder) and install assembly into piston #1 using Locktite #242, Position locking ring #4 with bent tab engaged in hole in piston #1. Tighten bushing assembly into piston as tightly as possible.
5. Place other locking ring #4 over exposed thread on bushing #2 with bent tab positioned to engage hole in piston #1. Install bushing nut #3 and tighten as tight as possible.
6. Bend one exposed tab on each locking ring #4 up against a flat surface of the hex on both the bushing #2 and bushing nut #3.
7. Allow assembly to set one hour minimum for Locktite to fix.

### Assembly of Power Unit (REF: TD-365), page 4

1. Lubricate I.D. of cylinder #26 and examine for surface defects.
2. Install piston seals ring #23 into last groove to inner cylinder #26 and insert piston #22 into cylinder.
3. Pass piston #22 through cylinder #26 until second groove is exposed.
4. Install other piston seal ring #23 and draw piston #22 back into cylinder 26.
5. Examine ends of cylinder for possible damage. Place o-ring #27 into groove in end cap #14 and install cylinder #26 into recess taking care not to pinch or otherwise damage o-ring.
6. Place o-ring #27 into groove in other end cap #14.
7. Insert power piston rod #39 through center hole in end cap #14.
8. Install tie rods #17. Torque hex nuts to approximately 130 ft.-lbs. Make sure end plates #14 are brought up uniformly.

9. Position manifold gaskets 21 and manifold #24 over ports in end caps #14 making sure that gaskets do not block ports.
10. Secure manifold #24 with hex head cap screws #2 by tightening to approximately 20-25 ft.-lbs.
11. Install valve gasket and spool valve #10 and secure to manifold #24 with 4 socket head cap screws #4.
12. Install pilot control lines #11.
13. Lubricate center bore of end cap #14 and O.D. of power piston rod #39 and install rod packing #28.
14. Install o-ring #29 and wiper ring #31 onto gland bushing #30.
15. Place gland bushing #30 over power piston rod #39 and seat into place against packing #28.
16. Position packing plate #20 against gland bushing #30 and tighten into place with 4 hex head cap screws #19. Do not over-tighten.
17. For double ended pumps, repeat steps 14 through 17 for opposite end. For single ended pumps, place o-rings #29 onto end plug #43. Lubricate with a suitable grease and install end plug into end cap #14.
18. Secure end plug #43 with packing plate #20 and 4 hex head cap screws #19 at approximately 10 ft.-lbs. torque.
19. Assemble 2 pilot valves (TB-928), steps (a) through (e)
  - (a) Install O-ring #7 into I.D. of sleeve #5.
  - (b) Install O-rings #6 and #4 onto O.D. of sleeve #5.
  - (c) Lubricate plunger #8 and insert into sleeve #5.
  - (d) Place spring #3 over exposed end of plunger #8.
  - (e) Install gasket #2 over end of adapter #1 and install adapter into sleeve #5.
20. Lubricate O.D. seals of adapter #38 and install one pilot valve assembly into each end cap #14.
21. Place retainer #32, 3 Belleville washers #33 and a back-up ring #34 over the end of the power piston rod #39.
22. Install spacer #42 onto end cap #14 using 8 cap screws #18. Spacer should be orientated with 1/2" drain on bottom. (Two spacers required for double ended pumps.)

**GAS OR AIR DRIVEN RECIPROCATING PUMPS** series**6100****Assembly Procedures of Head Assemblies 6111****Head Assembly (REF: page 6)**

1. Examine head body #13 to make sure valve cage seating surface and packing areas are free of nicks and burrs. Check all thread areas for condition of threads.
2. Install seal #8 onto seal surface.
3. Install lower valve cage #10 and ball #11 into valve bore of pump head #13.
4. Install O-rings #6 and back-up rings #5 onto spacer cage #7 and lubricate seal area.
5. Install spacer cage #7 from step 4 into pump head #13.
6. Install seal #8 onto seal surface inside spacer cage #7.
7. Install upper valve cage #10 and ball #11 into spacer cage.

**6111 Head Assembly cont'd. (REF: page 6)**

8. Install o-ring 6 and back-up ring #5 onto valve plug #4.
9. Place seal #8 on top surface of upper valve cage #11.
10. Install valve plug #4 from step 8 into top of pump body.
11. Place cover plate #3 over valve plug #4 and secure cover using 4 hex head cap screws #1 with lock washers #2. Torque to approximately 30-40 ft-lbs.
12. Install pipe plug #12 using Loctite pipe sealant or equal.
13. Install packing #15 and lantern ring #20.
14. Place packing gland #16 into packing gland nut #17 and thread assembly into pump body #13. Do not tighten more than hand tight.
15. Assemble ball connector cup #19 onto plunger #14 using Loctite 222 if available. Secure connection with set screw #18.
16. Lubricate plunger #14 and insert through packing end of pump head #13.
17. Install grease jack #9, containing 2 sticks of Chennola lubricant.

**NOTE:**

**When using teflon packing, replace grease jack with pipe plug.**

**6121 Head Assembly (REF: page 7)**

1. Examine head body #10 to insure valve cage seating surfaces and packing areas are free of nicks and burrs. Check threaded areas for thread condition.
2. Install seal #5 onto lower seal surface.
3. Install lower valve cage #7 and valve ball #6 into pump head #10.
4. Install spacer cage #7.
5. Install seal #5 onto top surface of spacer cage #7.
6. Install top valve cage #7 and valve ball #6 into pump head #10.
7. Place top seal #5 onto top surface of top valve cage #7.
8. Install valve plug #4.
9. Position cover plate #3 over valve plug #4 and secure using 2 hex head cap screws #1 with locknuts #2. Torque to approximately 30-40 ft-lbs.
10. Install pipe plug #9 using Loctite pipe seal or equal.
11. Insert packing #11 into packing bore of pump body #10.
12. Install packing gland #12 into packing gland nut #13 and thread assembly into pump body #10. Do not tighten more than hand tight.
13. Lubricate O.D. of plunger #14 and insert through packing end of pump head #10.

**6141 Head Assembly (REF: page 8)**

1. Examine pump head #20 to insure valve cage sealing surfaces and cylinder sealing surface are free of defects. Check thread areas for thread condition.
2. Install seals #21 onto lower seal surfaces of each cavity in pump head #20.
3. Install valve ball #18 into valve cage #19. Insert valve plug #15 into valve cage #19 and fasten with roll pin #17. Install o-ring #16 onto valve plug #15 and lubricate each cavity in pump head #20.
4. Insert plug & insert assembly into each cavity of pump head #20.
5. Install plug #27 as shown.

12. Install packing gland #12 into packing gland nut #13 and thread assembly into pump cody #10. Do not tighten more than hand tight.
13. Lubricate O.D. of plunger #14 and insert through packing end of pump head #10.

#### 6141 Head Assembly (REF: page 8)

1. Examine pump head #20 to insure valve cage sealing surfaces and cylinder sealing surface are free of defects. Check thread areas for thread condition.
2. Install seals #21 onto lower seal surfaces of each cavity in pump head #20.
3. Install valve ball #18 into valve cage #19. Insert valve plug #15 into valve cage #19 and fasten with roll pin #17. Install o-ring #16 onto valve plug #15 and lubricate each cavity in pump head #20.
4. Insert plug & insert assembly into each cavity of pump head #20.
5. Install plug #27 as shown.
6. Position cover plate #14 and secure using 3 hex head cap screws #13. Torque to approximately 20-30 ft.-lbs.
7. Assemble ball connector #1 onto end of piston rod #6 and secure with set screw, #22.
8. Install breather #23 and wiper ring #2 into end plug #3.
9. Insert piston rod #6 through end plug #2 as shown.

10. Position end plug #3 onto spacer and position cylinder #24 using 6 screws #5 and 6 washers #4. Flat end of cylinder must be used. Do not tighten this joint, leave at least 1/4" gap.
11. Install sleeve #25 into cylinder #24.
12. With piston rod #6 moved to full forward position, install o-ring #7, piston #8, piston cup #9, back-up retainer #11 and nut #12.
13. Install o-ring #26 and back up #29 onto end of sleeve #25,
14. Place assembled pump head from step 10 over end of sleeve #25. Secure cylinder #24 to pump head using 6 screws #5 and 6 washers #4, This joint should be brought face to face. If a gap exists, loosen joint made in step 13.
15. After tightening cylinder to head connection, then tighten cylinder to spacer connection. A gap will exist at this joint - do not over-tighten.

#### Assembly of Fluid End to Power Units (REF: page 4)

1. Insert ball joint thrust bearing #36 into connector cup.
2. Insert connector bearing ball #35 (on end of preassembled power piston rod #39) into connector cup and tighten retainer #32. Retainer should shoulder against end of connector cup without excessive pressure.



#### Dresser Industrial Products Group

16240 Port Northwest Drive  
Houston, Texas 77041-2645

Phone: 832.590.2306

Fax: 713.849.2879  
www.dresser.com



Dresser, Inc.