



series 2500

CHEMICAL INJECTION PUMPS



PRODUCT FEATURES

- Maximum discharge pressure: 6,000 PSI (414 bar) w/ 3/16" plunger
- Maximum volume 139 gallons per day (528 liters per day) w/ 1/2" plunger
- Each head is adjustable while running
- Available simplex, duplex, triplex, or quadruplex configurations
- Mix or match head sizes - pump the same or different chemicals
- Available in four stroke rates: 15, 30, 60, or 120 strokes per minute
- Each head is independently coupled - user friendly in the field
- 1/2 horsepower motor standard; 1 or 3 phase, TEFC or explosion proof; 50 or 60 hertz
- Available with 3/16", 1/4", 3/8", or 1/2" plunger

The 2500 Series of Texsteam chemical injection pumps are electric driven, positive displacement pumps utilizing C-faced motors and common gear reducers. The gear reducers are available in 15, 30, 60, and 120 strokes per minute configurations. By utilizing even further flexibility of a wide variety of plunger sizes, the 2500 Series can fill many application requirements of different flow and pressures.

The 2500 Series can have up to fluid ends, each driven off an eccentric cam gear which requires no oil.

Options:

Ceramic plungers which provide longer packing life and a wide variety of packing designed to meet the demands of many different chemical applications.

MODEL DESIGNATION

25F3 - 3

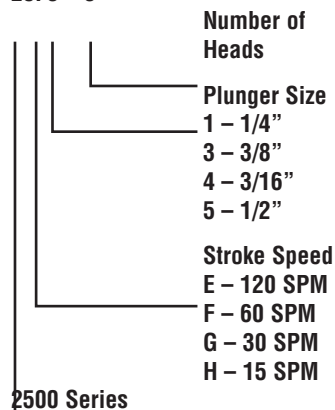

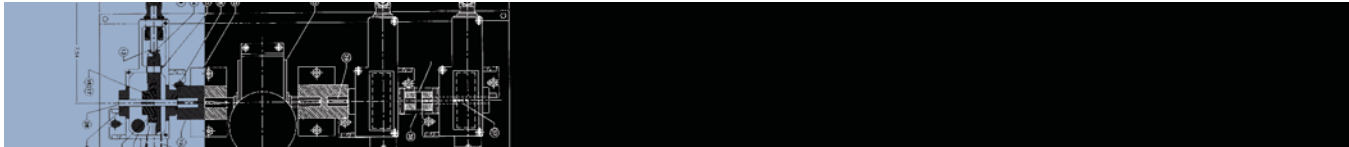

Plunger Size	Assembly Number
3/16"	TB-1560

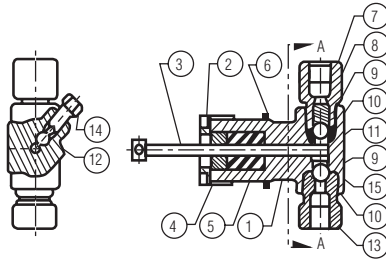

Plunger Size	Assembly Number
1/4"	TB-1557
3/8"	TB-1558
1/2"	TB-1559

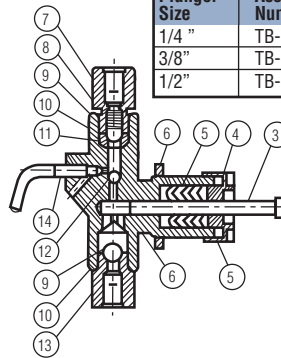

Item	Part #	Name	Material
1	TB-1483	Cover	ASTM A48 Cast Iron
2	TA-0136	1/4-20 x 3/4 Thumbscrew	Cad. Pl. Carbon Steel
3	TA-5821	Cover Gasket	Nitrile
4	TC-2048	Housing	ASTM A48 Cast Iron
5	TA-0142	HHCS 3/16"-18 x 1.25	Cad. Pl. Carbon Steel
6	TA-0144	Hex 5/16" 18 Nut	Cad. Pl. Carbon Steel
7	TA-0300	Cut Washer 5/16	Cad. Pl. Carbon Steel
8	TC-2071	Simplex Base Plate	Galvanized Steel
	TC-2072	Duplex Base Plate	Galvanized Steel
	TC-2073	Triplex Base Plate	Galvanized Steel
	TC-2074	Quadruplex Base Plate	Galvanized Steel
9*	TB-1560	1/16" Head Assy.	316SS
	TB-1557	1/4" Head Assy.	316SS
	TB-1558	3/8" Head Assy.	316SS
	TB-1559	1/2" Head Assy.	316SS
10	TA-5964	Cross Head Bearing	Nylon
11	TA-5965	Cross Head Bearing	Nylon
12	TA-5966	Screen	SS
13	TB-1542	Cross Head	AISI 4140 Hr Steel
14	TA-5823	Eccentric Cam	C1018 Steel
15	TA-5830	Roller Bearing	Steel
16	TA-5831	10-24 UNC x 1/4 Set Screw	Carbon Steel
17	TA-2824	Woodruff Key	Carbon Steel
18	TA-5832	Sleeve Bearing	Reinforced Steel
19	TA-5826	Shaft Guard	Plastic
20	CF	Reducer	
21	TA-5822	Stroke Adjustor	C1213 C.R.S.
22	TA-5824	Stroke Adjustor Lock Nut	416SS
23	TA-2825	Adjusting Screw	416SS
24	TC-2070	Coupling Cover	Plastic
25	TA-1836	Coupling	Steel
26	TA-5937	Key	Steel
27	TA-5937	Key	Steel
28	TA-5950	Tandem Shaft	Steel
29	TA-5953	Drive Clip	Steel
30	CF	Motor 1/2 HP	

Item	Description	Material	Part Number			
			3/16"	1/4"	3/8"	1/2"
1	Body	SS	TC 2040	TC 0291	TC 0425	TB 0349
2	Gland Nut	303-SS	TA 4104	TA 4104	TA 4104	TA 4104
3*	Plunger	17-4PH	TA 6082	TA 6079	TA 6080	TA 6081
4	Gland	303-SS	TA 5642	TA 1463	TA 0957	TA 1219
5	Plunger	Buna-N	TA 3969	TA 1461	TA 1456	TA 0959
	Packing**	Hard	TA 3948	TA 2295	TA 1875	TA 1874
		Viton	TA 3967	TA 4102	TA 4101	TA 4103
		Teflon	TA 3966	TA 1642	TA 1234	TA 1012
6*	LockNut	Brass	TA 0225	TA 0225	TA 0225	TA 0225
7	Top Bushing	303 SS	TA 1496	TA 1496	TA 1496	TA 1496
8*	Ball Check Spring	316-SS	TA 0077	TA 0077	TA 0077	TA 0077
9*	Large Ball 3/8"	316-SS	TA 0054	TA 0054	TA 0054	TA 0054
10*	O-Ring	Buna-N	TA 0479	TA 0479	TA 0479	TA 0479
		Viton	TA 2093	TA 2093	TA 2093	TA 2093
11	Top Check Seat	303-SS	TB 0734	TB 0734	TB 0734	TB 0734
12*	Small Ball 1/4"	316-SS	TA 0126	TA 0126	TA 0126	TA 0126
13	Bottom Bushing	303-SS	TB 1213	TB 1213	TB 1213	TB 1213
14	Priming Valve	303-SS	TA 5462	TA 1497	TA 1497	TA 1497
15	Gasket	304-SS	TA 4394			

Plunger Size	Material							
	Buna-N		Hard		Viton		Teflon	
	PSIG	Bars	PSIG	Bars	PSIG	Bars	Psig	Bars
3/16"	3000	(207)	6000	(414)	3500	(345)	3000	(207)
1/4"	2400	(165)	4000	(275)	3500	(240)	2400	(165)
3/8"	1500	(103)	1800	(124)	3500	(240)	1500	(103)
1/2"	1000	(69)	1025	(71)	3500	(240)	1000	(69)

Plunger Size	Strokes Per Minute	Maximum Discharge Press		Gallons Per Day (Liters)			
		PSI	(Bars)	Maximum		Minimum	
3/16"	15	6000	(414)	2.4	(9)	.2	(1)
	30	6000	(414)	4.9	(19)	.5	(2)
	60	6000	(414)	9.8	(37)	1.0	(4)
	120	4000	(275)	18.7	(71)	1.9	(7)
1/4"	15	3200	(221)	4.3	(16)	.4	(2)
	30	4000	(275)	8.6	(33)	.9	(3)
	60	4000	(275)	17.3	(65)	1.7	(7)
	120	2100	(145)	34.6	(131)	3.5	(13)
3/8"	15	1450	(100)	9.8	(37)	1.0	(4)
	30	180	(124)	19.6	(74)	2.0	(7)
	60	1700	(117)	39.2	(148)	3.9	(15)
	120	950	(65)	78.5	(297)	7.8	(30)
1/2"	15	82	(56)	17.4	(66)	1.7	(7)
	30	1025	(71)	34.8	(88)	3.5	(9)
	60	1000	(70)	69.7	(264)	7.0	(26)
	120	525	(36)	139.5	(528)	13.9	(53)

* For 50 cycle motors multiply above volumes by .8

GEAR REDUCER OIL LEVELS

Single Stage C-Mount
(input shaft/output shaft horizontal)

Two-Stage - Helical C-Mount
(input shaft horizontal)

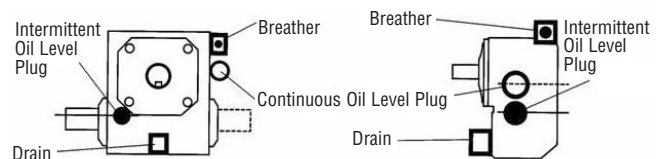

REDUCER OIL CHANGE

- Continuous run units Change every 2,000 hours
- Intermittent units: Change every 2,500 running hours or six months
- Use Mobil cylinder 600W, or Texaco meriopia 460 for 32°F to 100°F, or Mobil SHC 634 for 0°F to 135°F or an equivalent major oil brand.

USE INTERMITTENT (OR "HIGH") OIL LEVEL FOR OPERATION OF 800 RPM OR LESS OR FOR INPUT SHAFT SPEED OF 800 RPM OR LESS.

CHEMICAL INJECTION PUMPS

series **2500**

2500 SIMPLEX

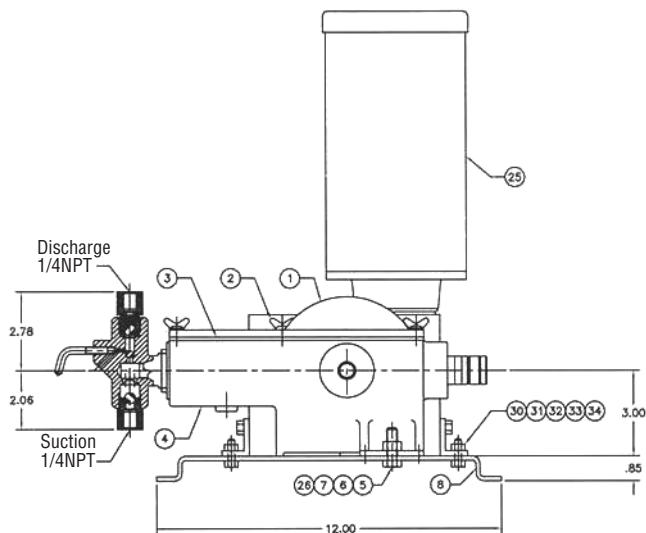
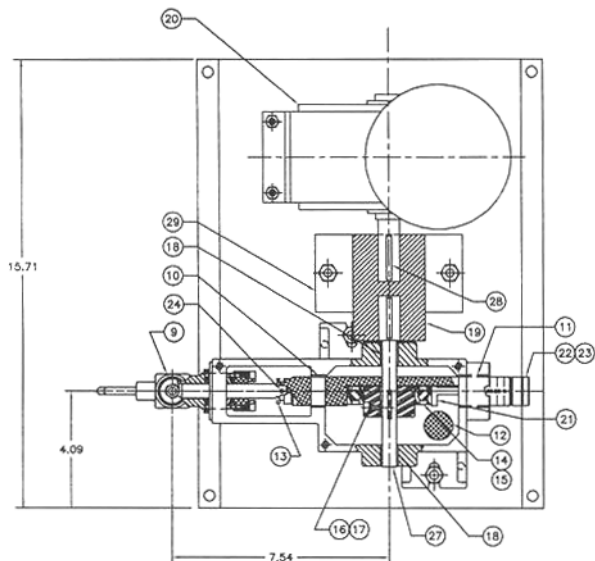

Parts List

Item	Part No.	No. Reqd.	Name	Material
1	TB-1483	1	Cover	ASTM A48 C.I.
2	P86-025075-0200	3	Thumbscr.	Cad. Pl. Steel
3	TA-5963	1	Gasket Cover	Nitrile
4	TC-2048	1	Housing	ASTM A48 C.I.
5	P01-031125-3900	2	HHCS 5/16-18	SS
6	P25-031000-3900	2	Nut Hex 5/16-18	Cad. Pl. Steel
7	P53-031000-3900	2	Cut Washer 5/16	Cad. Pl. Steel
8	TC-2197	1	Base Plate	Galv. Steel
9	TB-0755	1	1/4 SS LP Head Assy.	316 SS
10	TA-5964	1	Cross Head Bearing	Nylon
11	TA-5965	1	Cross Head Bearing	Nylon
12	TA-5966	1	Screen	SS
13	TB-1542	1	Cross Head	AISI 4140 HR Steel
14	TA-5823	1	Eccentric Cam	C 1018 Steel
15	TA-5830	1	Roller Bearing	Steel
16	P20-025050-0200	1	St. Scr.	Carbon Steel
17	TA-6386	1	Key	Carbon Steel
18	TA-6713	2	Sleeve Bearing	Reinforced Steel
19	TA-6714	1	Coupling	Steel
20		1	Reducer	
21	TA-5822	1	Stroke Adjustor	C1213 C.R.S
22	TA-5824	1	Lock Nut Stroke Adj.	416 SS
23	TA-5825	1	Adjusting Screw	416 SS
24	TA-5953	1	Drive Clip	Steel
25		1	Motor- 1/2 HP	
26	P52-031000-3900	2	Lock Washer 5/16	Cad. Pl. Steel
27	TB-1677	1	Drive Shaft	Steel
28	TA-6720	2	Drive Shaft Key	Steel
29	TB-1700	1	Coupling Guard	Plastic
30	P01-037125-3900	4	HHCS 3/8-16	
31	P25-037000-3900	4	Nut Hex 3/8-16	
32	P53-037000-3900	4	Cut Washer 3/8	
33	P52-037000-3900	4	Lock Washer 3/8	
34	TA-6716	4	Spacer	

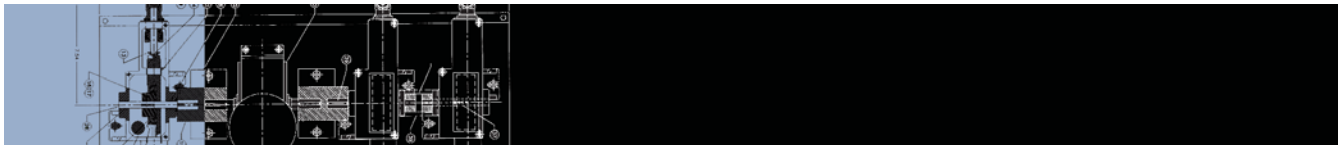

2500 DUPLEX

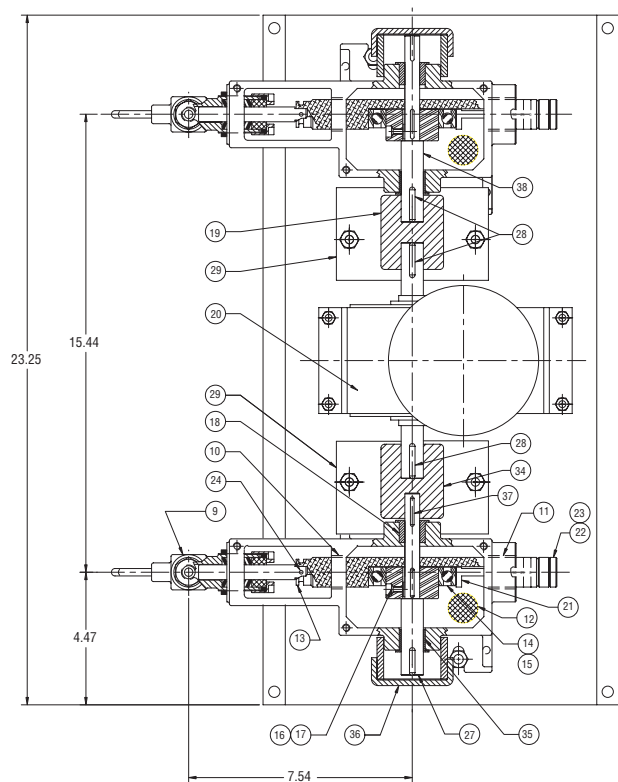

Parts List

Item	Part No.	No. Reqd.	Name	Material
1	TB-1483	2	Cover	ASTM A48 C.I.
2	P86-025075-0200	6	Thumbscr.	Cad. Pl. Steel
3	TA-5963	2	Gasket Cover	Nitrile
4	TC-2048	2	Housing	ASTM A48 C.I.
5	P01-031125-3900	4	HHCS 5/16-18	SS
6	P25-031000-3900	4	Nut Hex 5/16-18	SS
7	P53-031000-3900	4	Cut Washer 5/16	SS
8	TC-2197	1	Base Plate	Galv. Steel
9	TB-0755	2	1/4 SS LP Head Assy.	316 SS
10	TA-5964	2	Cross Head Bearing	Nylon
11	TA-5965	2	Cross Head Bearing	Nylon
12	TA-5966	2	Screen	SS
13	TB-1542	2	Cross Head	AISI 4140 HR Steel
14	TA-5823	2	Eccentric Cam	C 1018 Steel
15	TA-5830	2	Roller Bearing	Steel
16	P20-025050-0200	2	St. Scr.	Cad. Pl. Steel
17	TA-6386	2	Key	Steel
18	TA-6935	2	Sleeve Bearing-Small	Nylon
19	TA-6714	1	Coupling-Drive	Steel
20		1	Reducer	
21	TA-5822	2	Stroke Adjustor	C1213 C.R.S
22	TA-5824	2	Lock Nut Stroke Adj.	416 SS
23	TA-5825	2	Adjusting Screw	416 SS
24	TA-5953	2	Drive Clip	Steel
25		1	Motor- 1/2 HP	
26	P52-031000-3900	4	Lock Washer 5/16	SS
27	TB-1735	1	Drive Shaft - DPLX	17-4PH. SS
28	TA-6720	3	Drive Shaft Key	Steel
29	TB-1736	2	Coupling Guard	Galv. Steel
30	P01-037125-3900	4	HHCS 3/8-16	SS
31	P25-037000-3900	4	Nut Hex 3/8-16	SS
32	P53-037000-3900	4	Cut Washer 3/8	SS
33	P52-037000-3900	4	Lock Washer 3/8	SS
34	TA-6953	1	Coupling-Drive	Steel
35	TA-6936	2	Sleeve Bearing-Large	Nylon
36	TA-6938	2	Shaft End Cap	Plastic
37	TA-5937	1	Shaft Key	Steel
38	TB-1734	1	Drive Shaft - SPLX	17-4PH. SS

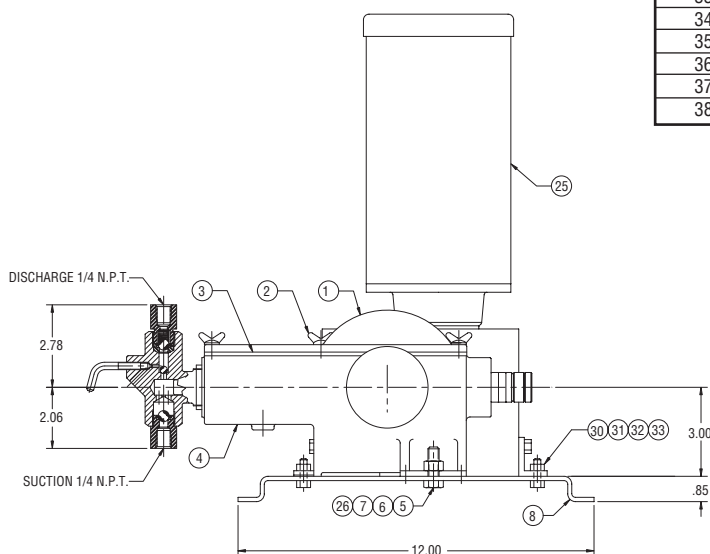

CHEMICAL INJECTION PUMPS

series **2500**

2500 TRIPLEX

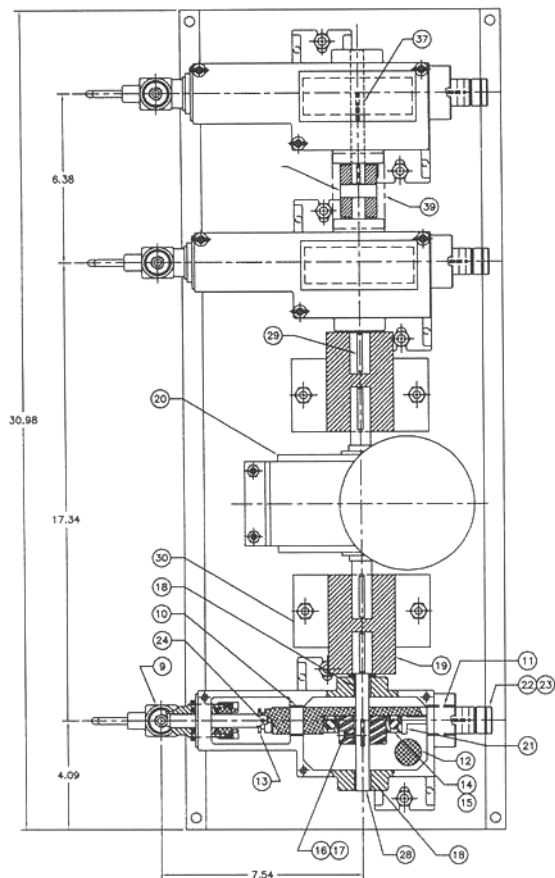

Parts List

Item	Part No.	No. Reqd.	Name	Material
1	TB-1483	3	Cover	ASTM A48 C.I.
2	P86025075-0200	9	Thumbscr.	Cad. Pl. Steel
3	TA-5963	3	Gasket Cover	Nitrile
4	TC-2048	3	Housing	ASTM A48 C.I.
5	P01-031125-3900	6	HHCS 5/16-18	SS
6	P25-031000-3900	6	Nut Hex 5/16-18	SS
7	P53-031000-3900	6	Cut Washer 5/16	SS
8	TC-2197	1	Base Plate	Galv. Steel
9	TB-0755	3	1/4 SS LP Head Assy.	316 SS
10	TA-5964	3	Cross Head Bearing	Nylon
11	TA-5965	3	Cross Head Bearing	Nylon
12	TA-5966	3	Screen	SS
13	TB-1542	3	Cross Head	AISI 4140 HR Steel
14	TA-5823	3	Eccentric Cam	C 1018 Steel
15	TA-5830	3	Roller Bearing	Steel
16	P20-025050-0200	3	St. Scr.	Cad. Pl. Steel
17	TA-6386	3	Key	Steel
18	TA-6935	3	Sleeve Bearing, Small	Nylon
19	TA-6714	1	Coupling Drive	Steel
20		1	Reducer	
21	TA-5822	3	Stroke Adjustor	C1213 C.R.S
22	TA-5824	3	Lock Nut Stroke Adj.	416 SS
23	TA-5825	3	Adjusting Screw	416 SS
24	TA-5953	3	Drive Clip	Steel
25		1	Motor- 1/2 HP	
26	P52-031000-3900	6	Lock Washer 5/16	SS
27	TB-1735	1	Drive Shaft - DPLX	17-4 PH. SS
28	TA-6720	6	Drive Shaft Key	Steel
29	TB-1736	1	Coupling Guard	Galv. Steel
30	P01-037125-3900	3	HHCS 3/8-16	SS
31	P25-037000-3900	3	Nut Hex 3/8-16	SS
32	P53-037000-3900	3	Cut Washer 3/8	SS
33	P52-037000-3900	3	Lock Washer 3/8	SS
34	TA-6953	1	Coupling Drive	Steel
35	TA-6936	3	Sleeve Bearing, Large	Nylon
36	TA-6938	1	Shaft End Cap	Plastic
37	TA-5937	3	Shaft Key	Steel
38	TB-1734	1	Drive Shaft - Splx.	17-4 PH. SS
39	TA-6954	1	Coupling Drive	Steel
40	TC-2070	1	Coupling Guard	Plastic
41	TA-4251	1	Spacer	Nylon

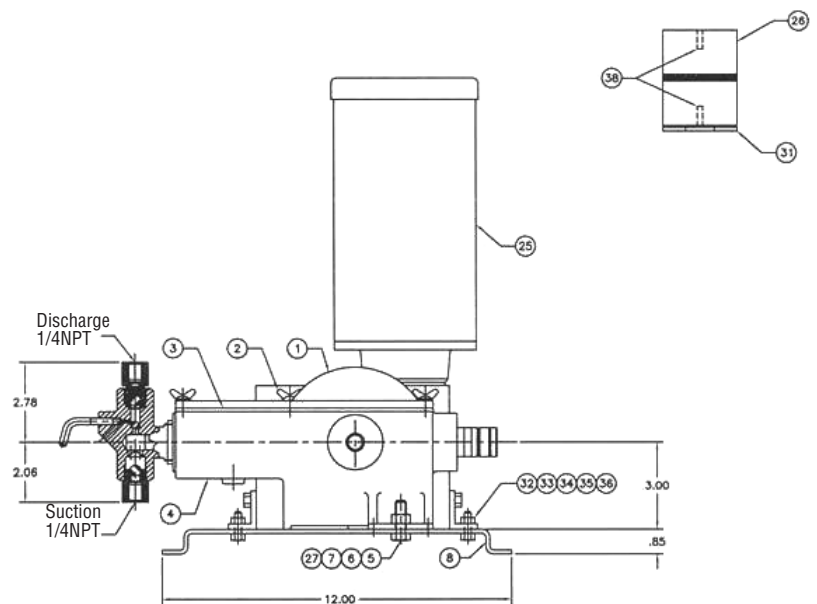

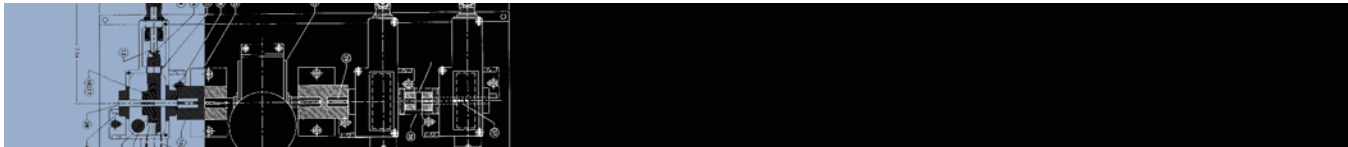

2500 QUADRUPLEX

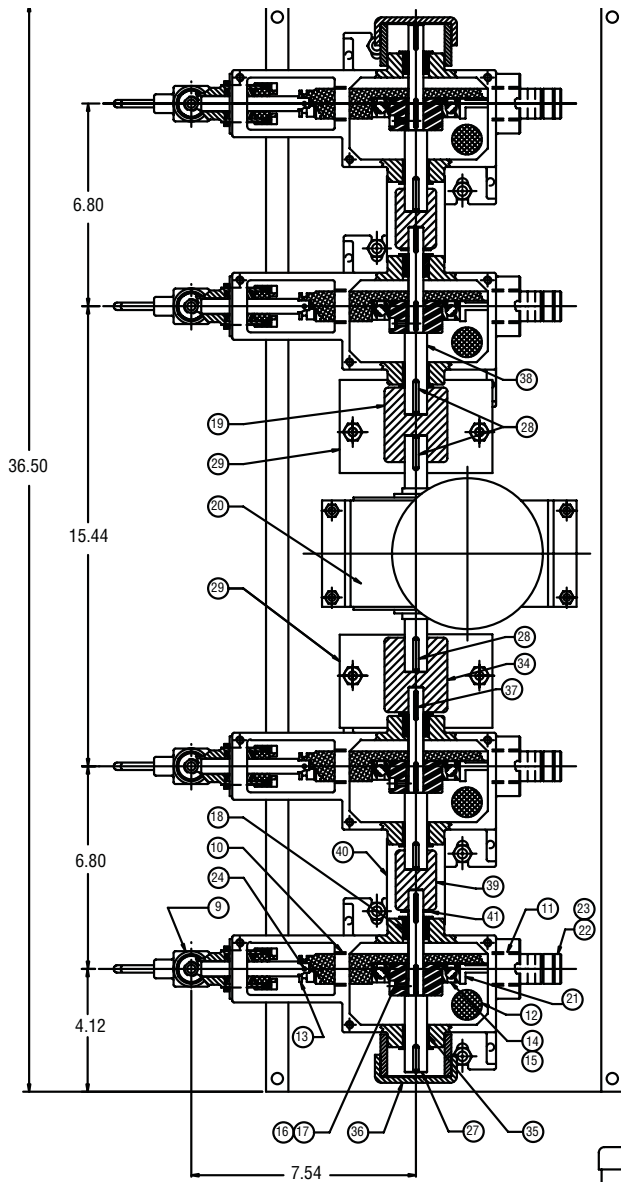

Parts List

Item	Part No.	No. Reqd.	Name	Material
1	TB-1483	4	Cover	ASTM A48 C.I.
2	P86025075-0200	12	Thumbscr.	Cad. Pl. Steel
3	TA-5963	4	Gasket Cover	Nitrile
4	TC-2048	4	Housing	ASTM A48 C.I.
5	P01-031125-3900	8	HHCS 5/16-18	SS
6	P25-031000-3900	8	Nut Hex 5/16-18	SS
7	P53-031000-3900	8	Cut Washer 5/16	SS
8	TC-2197	1	Base Plate	Galv. Steel
9	TB-0755	4	1/4 SS LP Head Assy.	316 SS
10	TA-5964	4	Cross Head Bearing	Nylon
11	TA-5965	4	Cross Head Bearing	Nylon
12	TA-5966	4	Screen	SS
13	TB-1542	4	Cross Head	AISI 4140 HR Steel
14	TA-5823	4	Eccentric Cam	C 1018 Steel
15	TA-5830	4	Roller Bearing	Steel
16	P20-025050-0200	4	St. Scr.	Cad. Pl. Steel
17	TA-6386	4	Key	Steel
18	TA-6935	4	Sleeve Bearing, Small	Nylon
19	TA-6714	1	Coupling Drive	Steel
20		1	Reducer	
21	TA-5822	4	Stroke Adjustor	C1213 C.R.S
22	TA-5824	4	Lock Nut Stroke Adj.	416 SS
23	TA-5825	4	Adjusting Screw	416 SS
24	TA-5953	4	Drive Clip	Steel
25		1	Motor- 1/2 HP	
26	P52-031000-3900	8	Lock Washer 5/16	SS
27	TB-1735	2	Drive Shaft - DPLX	17-4 PH. SS
28	TA-6720	5	Drive Shaft Key	Steel
29	TB-1736	2	Coupling Guard	Galv. Steel
30	P01-037125-3900	4	HHCS 3/8-16	SS
31	P25-037000-3900	4	Nut Hex 3/8-16	SS
32	P53-037000-3900	4	Cut Washer 3/8	SS
33	P52-037000-3900	4	Lock Washer 3/8	SS
34	TA-6953	1	Coupling Drive	Steel
35	TA-6936	4	Sleeve Bearing, Large	Nylon
36	TA-6938	2	Shaft End Cap	Plastic
37	TA-5937	3	Shaft Key	Steel
38	TB-1734	2	Drive Shaft - Splx.	17-4 PH. SS
39	TA-6954	2	Coupling Drive	Steel
40	TC-2070	2	Coupling Guard	Plastic
41	TA-4251	2	Spacer	Nylon

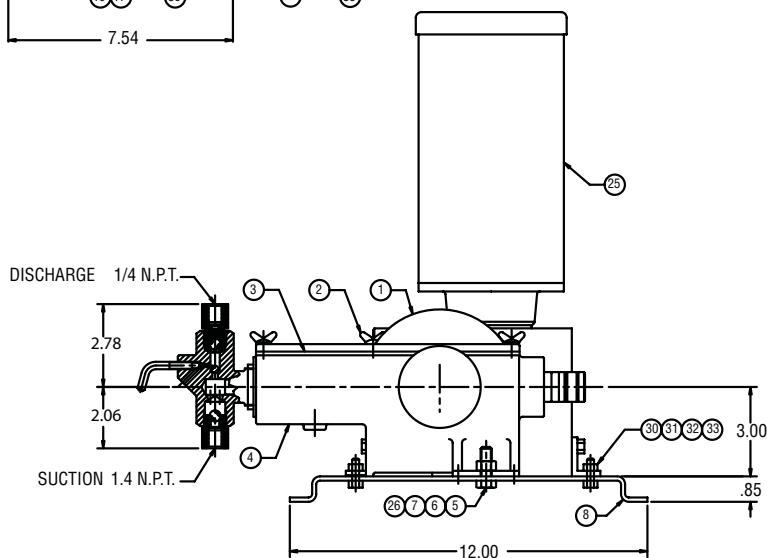

CHEMICAL INJECTION PUMPS

series **2500**

INSTALLATION AND START-UP INSTRUCTIONS

INSTALLATION

Pump Location - An Important Factor

- Plan ahead for proper pump mounting-position it to provide for efficient routing of suction and discharge lines, as well as electric service
- Avoid long suction lines
- Provide for a flooded suction line whenever possible
- Pump fluid lines and connections operate best when there is a minimum restriction to the medium flow
- Install the proper electrical starters and disconnect switches
- It is recommended that a solid mounting support be provided—take advantage of the factory installed holes in the base plate for securing the pump

FLUID END

- All fluid connections, both suction and discharge, should be sealed tight. Fluid end connections are 1/4" NPT
- The suction connection is at the bottom of the fluid end, and the discharge connection is at the top.

MOTOR

- A conduit connection is provided at the motor for electrical connections.
- Assure the proper electrical service has been provided
- Assure all connections are tight, in their proper location, properly grounded, and fused

GEAR REDUCER

- Check the oil level of the gear reducer
- If the oil level is below the output shaft oil plug, refill to the plug Mobil Cylinder Oil 600W or Texaco Metropia 460
- For low temperature applications, use Mobil SHC 634

START UP

- Open the priming valve on the fluid end assembly
- Start the pump motor
- Allow the pump to run until a clear, bubbleless stream of media comes out of the priming valve
- Close the priming valve
- Check the packing for proper sealing. If it leaks, stop the pump and make the necessary adjustments.
- Adjust the stroke adjustment knob to obtain the desired flow rate.

PREVENTIVE MAINTENANCE

- Check periodically (minimum once a month) and apply a small amount of grease to the cam bearing and to the crosshead areas that cycle through the linear bearings.
- Check the packing regularly. If leakage is observed, stop the pump. Make a small adjustment by turning the gland nut. Restart the pump. (Do not over-tighten the packing as this will reduce the packing life and possibly damage the plunger.

It is always important to assure the packing material is compatible with the media being pumped—check for swollen or deteriorated seals.