

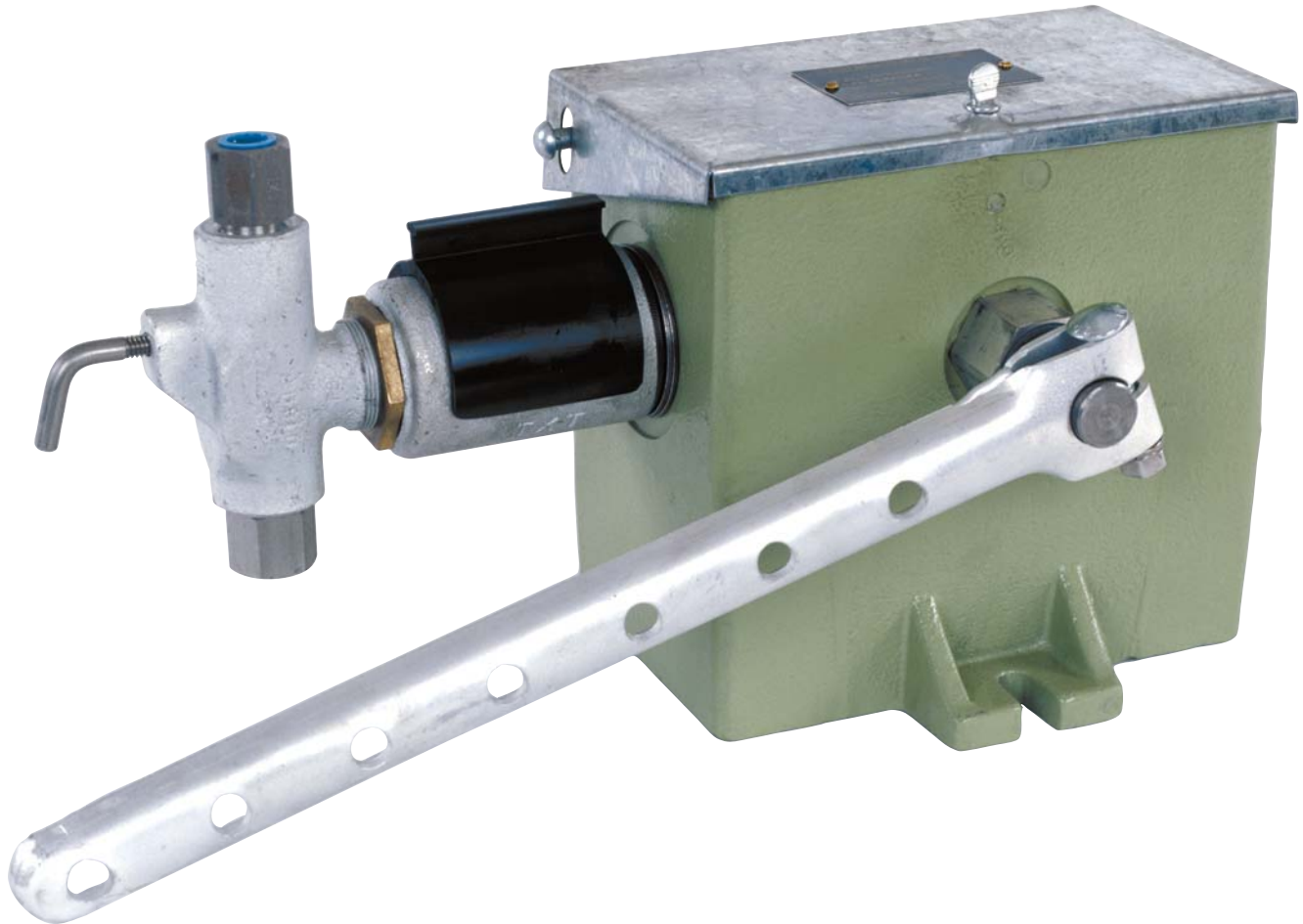

series 1200

BEAM DRIVEN CHEMICAL INJECTORS



DESCRIPTION

Designed specifically for operation on a beam pumped oil well, TXT 1200 Series Chemical Injectors are positive displacement type pumps powered by direct connection to the movement of a walking beam, rod line or rocker arm. The connection is made by a length of nominal pipe, or a wire line. The unit pumps on the upstroke of the beam action. On the downstroke, the injector arm returns to its set position. The ratchet mechanism is housed in a precision-bored, heavy cast gray iron case and is submerged in oil for long life.

APPLICATIONS

- Injection of de-emulsifiers, solvents, corrosion inhibitors, scale inhibitors, lubricants and other chemicals
- High pressure bearing lubrication
- Pumping thin or viscous fluids or non-abrasive slurries

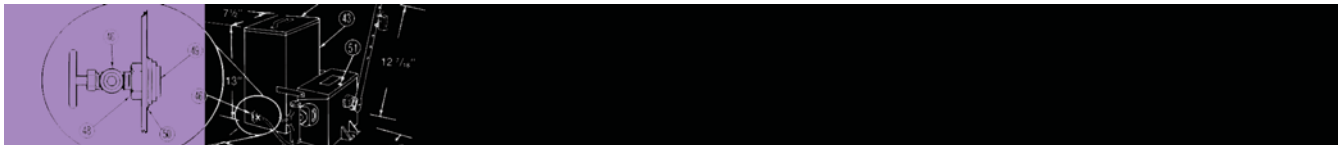

OUTSTANDING FEATURES OF THE TEXSTEAM SERIES 1200 CHEMICAL INJECTORS

PUMP HEAD ASSEMBLY

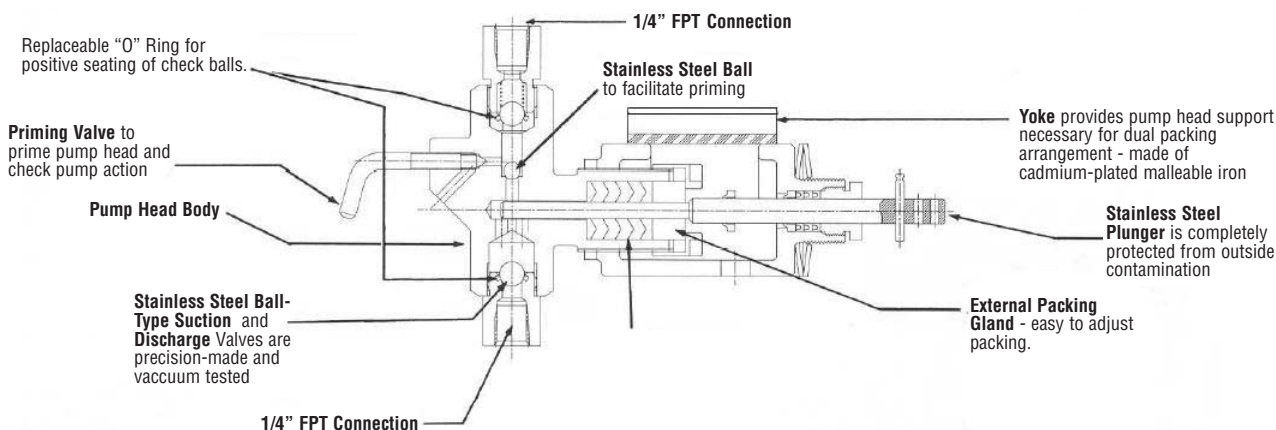

The TXT Pump Head is efficient because of the horizontal plunger and vertical check valves; virtually trouble-free; easy to maintain; has stainless steel trim in standard heads; built-in priming valve to aid in priming, check pump action and catch chemical samples and external packing gland.

The box assembly is heavy cast gray iron for maximum rigidity and has a galvanized lid and rigid galvanized lever arm. The pump head can be easily removed for cleaning and maintenance. An additional pump head can be installed if more volume is required or if there is a need to pump dissimilar fluids.

A wide choice of model and plunger sizes is available. The Series 1200 can be supplied with or without unitized chemical tanks or with two mounted tanks or with tanks of various capacity and materials to suit the operating requirements.

BOX ASSEMBLY

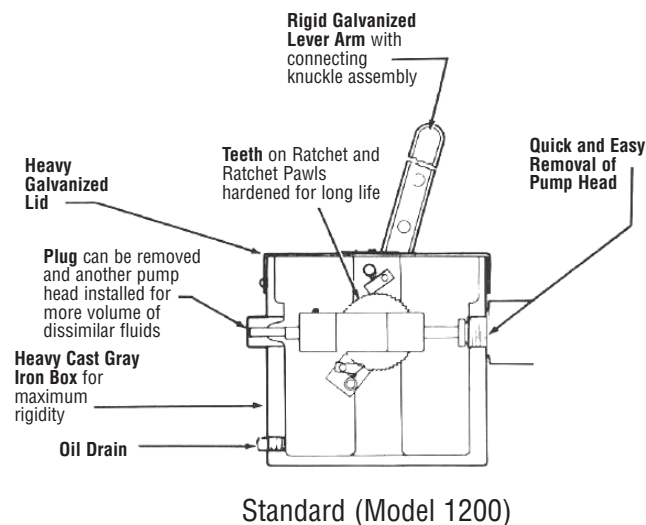

GENERAL ASSEMBLY

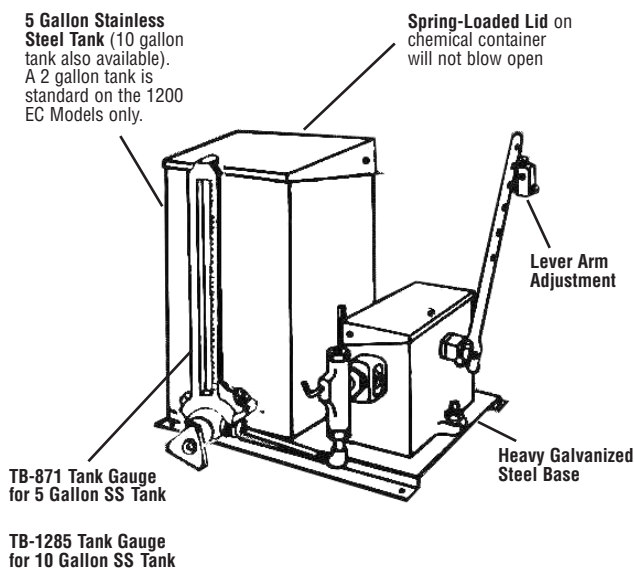

TA-676 1/4" Brass Line Check - furnished with each unit except on 1200 EC Models (not shown on illustration - see pg. 7)

BEAM DRIVEN CHEMICAL INJECTORS

series **1200**

MODELS AVAILABLE

Standard Model Number

- Single Pump Head & 2 Gallon SS Tank1203 EC
- Single Pump Head & Single 5 Gallon Tank1203 S
(Specify SS or Plastic Tank)
- Double Pump Head & Double 5 Gallon Tank1203 D
(Specify SS or Plastic Tanks)
- Single Pump Head (No Tank or Base)1203 SP
- Double Pump Head (No Tank or Base)1203 DP

Plunger Sizes

Model numbers shown are equipped with 3/8" plunger size. Other sizes available are 3/16", 1/4", and 1/2".

Choice of Material

Ductile Iron Body with stainless steel trim (Standard)
All Stainless Steel Head (Optional)

Options Available

Teflon or Viton Packing
Resilient seats (Standard on all heads)
Hastelloy balls
Tanks, two, five and ten gallon capacity, 430 SS and 316 SS

MODEL DESIGNATION

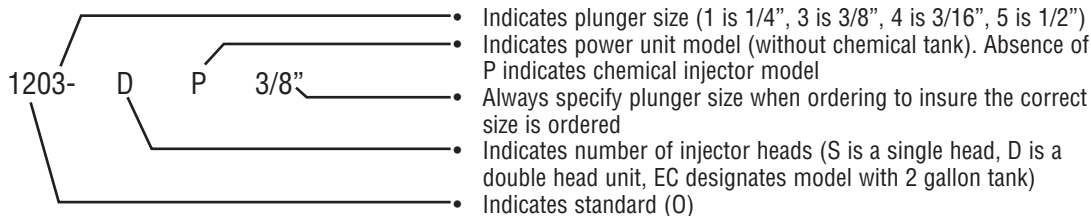

* shipping weights

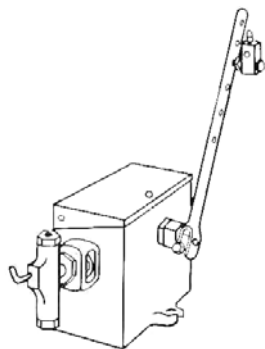

1200 SP *(26 lbs.)

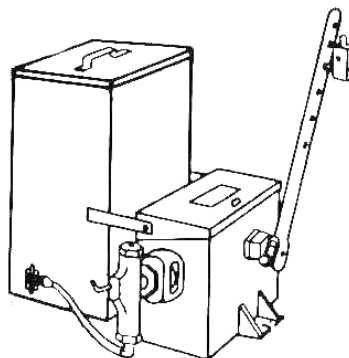

1200 EC *(32 lbs.)

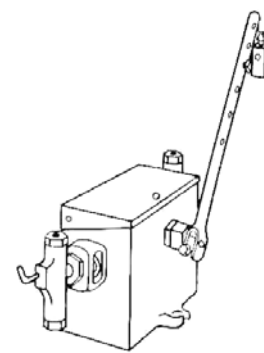

1200 DP *(30 lbs.)

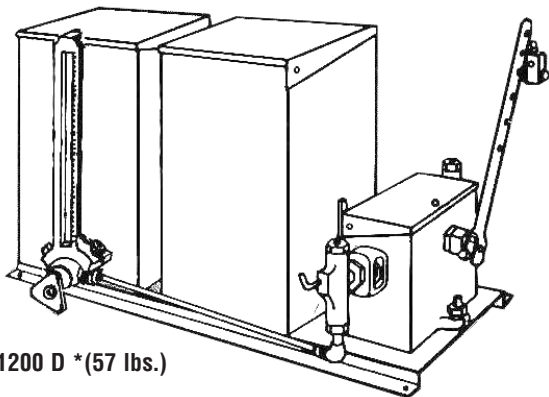

1200 D *(57 lbs.)

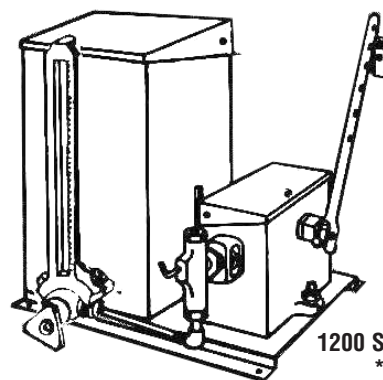

1200 S with SS Tank *(57 lbs.)

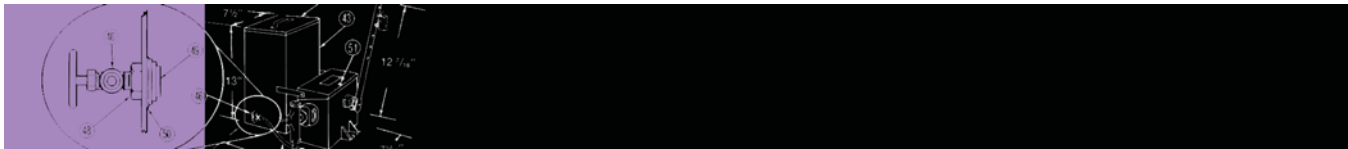

INSTALLATION & OPERATING INSTRUCTIONS

1. Remove pump from carton and inspect for possible damage in transit from factory. The cardboard carton was designed especially for this pump. If the pump has been damaged in transit, file claim with the carrier.
2. Bolt holes are provided for a permanent mounting (see drawing for dimensions on page 6).
3. Install Item 8 priming valve (included with pump, but shipped loose in carton) on the pump head.
4. Connect the suction line to the pump head.
 - a. If a reservoir is furnished with the pump, the suction line is already connected. Fill the reservoir and open (all the way) the tank gauge valve.
 - b. If a power unit model was purchased, a strainer should be piped in to the suction line to prevent sand, rust or other particles which would injure the plunger and foul the check valves.
5. Connect the discharge line (5/16" copper tubing will suffice). A TA-676 1/4" brass line check is provided. This valve should be installed as close to the point of injection as possible. Note the arrow on the check valve indicates the flow. The top connection on the pump head is the outlet and has a 1/4" female pipe thread connection.
6. Connect lever arm to the power source as follows: (make sure the walking beam pump is turned off)
 - a. 3/8" OD rod or pipe (usually 10' to 12' is required for an oil field walking beam pump). Attach a TA-700 TXT beam clamp (available from Texsteam) to the power source, such as a walking beam. Insert rod or pipe in the Item 42 beam clamp and the Item 6 connecting knuckle on the lever arm; tighten set screws to secure position of rod or pipe.
 - b. Wire line. Simply attach to walking beam and Item 6 connecting knuckle.
7. Fill the Item 25 box assembly with enough SAE-30 oil to cover the Item 40 bearing. If low ambient temperatures are encountered a lighter oil such as SAE-10 should be used. Check oil level at regular intervals.
8. Adjust for desired volume by considering each of the following:
 - a. Number of strokes of lever arm. The fastest recommended operating speed is 50 strokes per minute. Refer to the volume chart to obtain desired setting of ratchet teeth engagement and stroke length at strokes minute used.
 - b. Number of ratchet teeth engaged per stroke is dependent upon the travel of the TB-67 lever. With the Item 6 connecting knuckle in the outermost position, a travel of approximately 1" will engage one tooth. A maximum of 19" will engage twenty teeth.

- c. Adjustment of stroke teeth to short, medium, or long is easily accomplished by positioning of the TA-290 cotter pin in the end of the plunger.

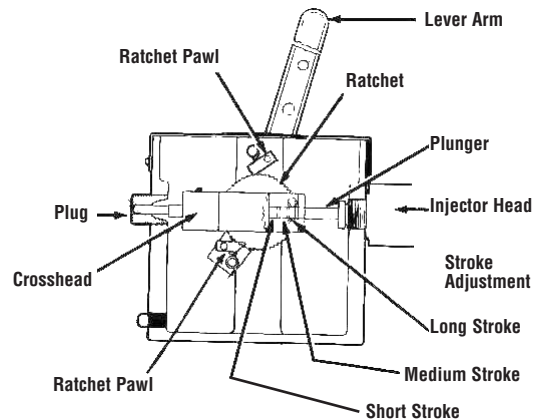

A quick calculation of the preceding three factors (8a, 8b and 8c) and using the performance data chart can predetermine the injection rate before the pump is placed in operation. If more volume is required the pump head assembly can be changed or converted to a larger plunger size. Or, an additional head can be installed on the opposite side of the TB-91 box by removing the TA-434 guide plug assembly. The TA-883 guide sleeve should also be removed and this can be accomplished with a drift and hammer.

9. Start prime mover and prime the pump head by opening the priming valve. After the pump discharges clear fluid without bubbles, close the priming valve for normal operations. At this point make a visual check of the plunger drip; slowly tighten the gland to prevent excess drippage and waste of chemicals. **Do not over-tighten plunger packing.** It may be necessary to readjust the packing the next day. A slight leak during the break-in is beneficial. Sufficient time should be allowed to let the packing "seat in."

If low volumes are being pumped, the pump head, the fluid discharge line and all other fittings up to the line check should be thoroughly purged of all air bubbles.

Check pump action by opening the priming valve.

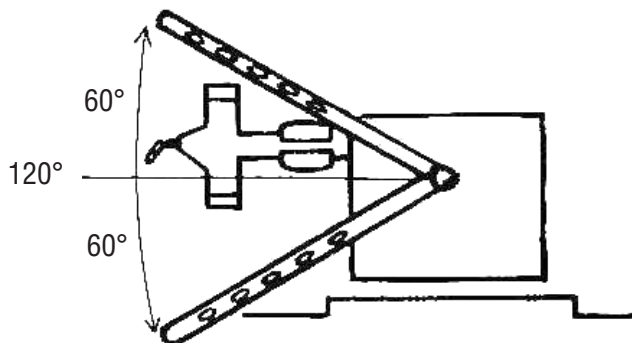

When lever arm cannot travel below the level of the bottom of the base, the maximum teeth engagement will be 10.

BEAM DRIVEN CHEMICAL INJECTORSseries **1200****PERFORMANCE DATA**

Plunger Size	Maximum Pressure	Volume Pints per Day		Model Number
		Min.	Max.	
3/16"	3000#	.5	4.4	1204
1/4"	1500#	.5	7.2	1201
3/8"	1000#	.5	18.0	1203
1/2"	500#	1.0	30.0	1205

* For Volumes With Additional Ratchet Teeth Engaged, Multiply These Values By Number of Teeth Engaged.
20 Teeth Maximum Pickup. Minimum Volumes are theoretical only.
NOTE - For double-headed units, increase maximum volume by two.
Series 1200 EC equipped with one head only.

Strokes Min.	Ratchet Teeth Engaged	3/16" Plunger			1/4" Plunger			3/8" Plunger			1/2" Plunger		
		Short Stroke	Med. Stroke	Long Stroke	Short Stroke	Med. Stroke	Long Stroke	Short Stroke	Med. Stroke	Long Stroke	Short Stroke	Med. Stroke	Long Stroke
6	1	.02	.05	.07	.04	.08	.12	.10	.20	.30	.17	.35	.5
8	1	.03	.07	.10	.06	.10	.16	.14	.26	.40	.23	.47	.7
10	1	.04	.08	.12	.07	.13	.20	.17	.33	.50	.29	.59	.8
12	1	.05	.10	.15	.08	.16	.24	.20	.40	.60	.35	.71	1.0
14	1	.06	.11	.17	.10	.18	.28	.24	.46	.70	.40	.83	1.2
16	1	.07	.13	.20	.11	.21	.32	.27	.53	.80	.46	.94	1.4
18	1	.08	.15	.22	.13	.23	.36	.31	.59	.90	.52	1.06	1.5

MAINTENANCE INSTRUCTIONS FOR SERIES 1200 BEAM DRIVEN CHEMICAL INJECTORS

(Refer to Parts List on Page 6)

To Remove TB-67 Lever

Remove TA-414 lever bolt assembly. TB-67 lever can then be pulled free of TB-66 drive shaft assembly. Upon re-assembly, be sure TA-414 fits into the slot in the end of TB-66 drive shaft assembly.

To Remove TA-536 Crosshead

It is not necessary to remove the pump head from a single-headed unit in order to remove the crosshead if the following steps are taken.

1. Hand operate TB-67 lever until chemical plunger is at its full discharge position.
2. Pull TA-290 pin (disconnecting plunger from TA-536 crosshead).
3. Remove TA-434 guide plug assembly.
4. Hand operate TB-67 lever until fluid plunger is free of TA-536 crosshead. Lift out TA-536 crosshead. To remove TA-536 crosshead from double-headed unit it is necessary to remove one pump head from the gear box.

To Remove TA-337 Ratchet Sub-Assembly

It is necessary to follow the procedure outlined under "To Remove TA-536 Crosshead" and "To Remove TB-67 Lever."

1. After crosshead is removed, TA-537 sub-assembly may be pulled toward center of gear box and lifted out.
2. To remove TA-457 bearing and TA-458 washer from TA-420 ratchet assembly, unscrew TA-433 bearing bolt.

To remove TB-66 drive shaft assembly, follow the procedure outlined above.

1. Unscrew the TA-S 199 shaft bearing. TB-66 drive shaft assembly can then be lifted out through the gear box. Installing TA-5200 shaft seal in TA-5199 shaft bearing: The TA-5200 seal is pressed into the TA-5199 bearing. When done correctly the garter spring will not be visible on the assembly.

Replacing Ratchet Pawls TA-455 and Ratchet Pawl Springs TA-456

It is necessary to remove TA-537 ratchet sub-assembly.

To Repack Fluid Pump Head

1. Disconnect chemical suction line.
2. Pull TA-290 pin.
3. Entire fluid head can now be unscrewed from gear box.
4. Loosen gland nut.
5. Pull chemical plunger from head.
6. Remove TA-4094 packing nut. This gives access to the yoke packing.
7. Loosen TA-225 lock nut. Yoke can then be unscrewed from fluid head (while unscrewing the yoke the gland nut must also be backed-off). At this point, wiper washer, gland nut and packing gland nut can be removed. This gives access to the main plunger packing.

To Check Discharge Balls, Seats & Springs

Remove TA-1496 top bushing.

To Check Suction Ball

Remove TB-736 bottom bushing (suction seat is integral part of TB-736 suction bushing).

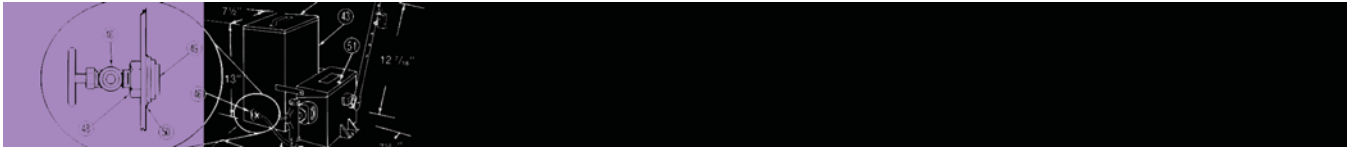

PARTS LIST

Item	Part No.	Name
1	TA-664	Reservoir Assy, 5 gal. 430SS
	TA-1539	Reservoir Assy, 10 gal. 304SS
	TA-2057	Reservoir Assy, 5 gal. 316SS
2	TA-3117	Suction Line
3	TA-3118	Connector compression nut assy.
4	TA-1497	Priming Valve
5	TB-0038	Sight Feed Assy.
6	TA-0538	Connecting Knuckle Assy.
7	TB-101	Base for two 5 gal. SS tanks
9	TA-306	Gasket
10	TA-302	Strainer Bushing Assy.
11		Head Assy. (see page 8 for parts breakdown)
14	TB-871	Tank Gauge Assy. for 5 gal. SS tank
	TB-1285	Tank Gauge Assy. for 10 gal SS tank
15	TA-3120	Suction Line
16	TA-3117	Suction Line
17	TA-98	Bowl
18	TA-206	Strainer
19	TA-104	Bowl Gasket
20	TB-39	Slight Feed Body
21	TA-101	Shut-off Assy.
22	TA-1842	Cover Rod
	TA-1841	Snap Ring (2 req'd)
23	TB-67	Lever Arm
24	TA-960	Lid
25	TA-91	Box Assy. 1200
26	TA-3116	Elbow Compression Nut Assy.
27	TA-677	Outlet Body Brass
28	TA-391	Spring
29	TA-54	Ball
30	TA-479	O-Ring Buna-N
	TA-2093	O-Ring Viton
31	TA-678	Inlet Body-Brass
32	TA-144	Nut Qty. (depends on location of usage)
	TA-425	Lock Washer Qty. (depends on location of usage)
34	TA-300	Washer Qty. (depends on location of usage)
	TA-453	Set Screw
36	TA-423	Beam Clamp

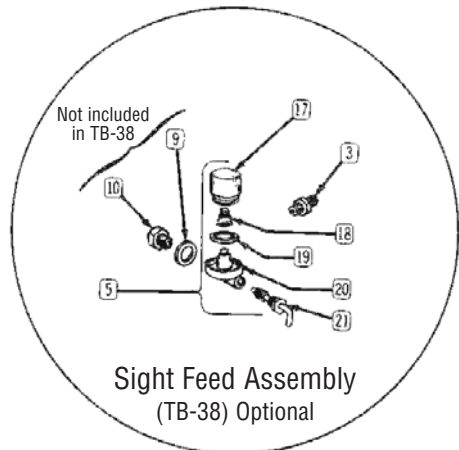
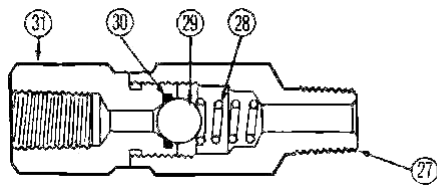
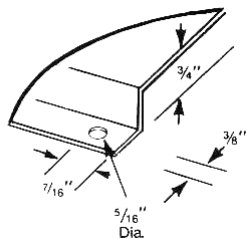
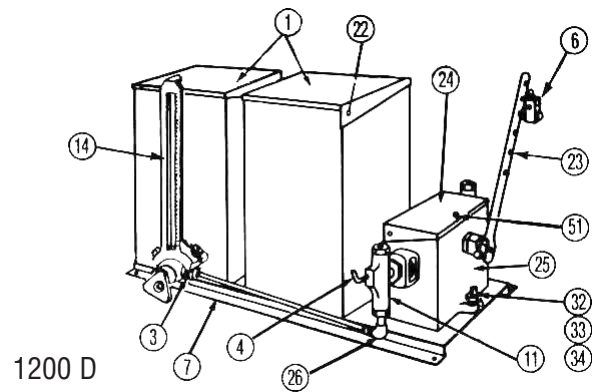
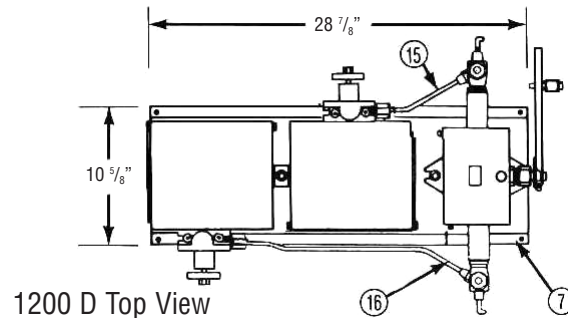
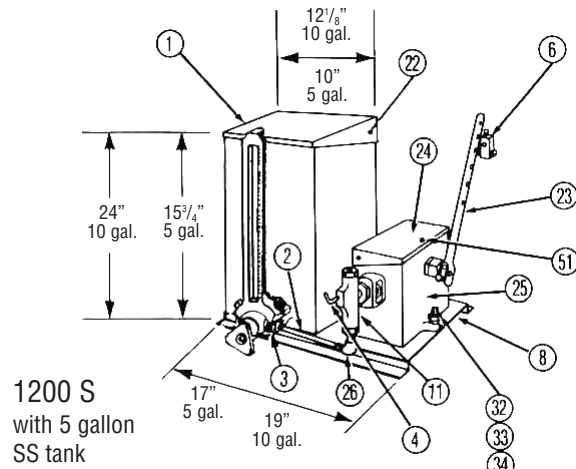

BEAM DRIVEN CHEMICAL INJECTORS

series **1200**

PARTS LIST

Item	Part No.	Name
38	TA-452	Set Screw
39	TA-439	Hex Nut
40	TA-409	Connecting Knuckle
41	TA-438	Cap Screw
42	TA-700	Beam Clamp Assy.
43	TA-460	2 Gal. Tank (incl. cover) 430 SS
44	TA-456	Cover
45	TA-246	Elbow
46	TA-2579	Shut-Off Valve
47	TA-322	Suction Line Assy.
48	TA-1748	Locknut
49	TA-1747	Strainer Bushing Assy.
50	TA-306	Bushing Gasket
51	TA-2577	LID Thumb Screw

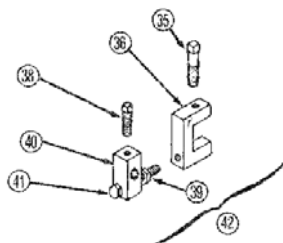
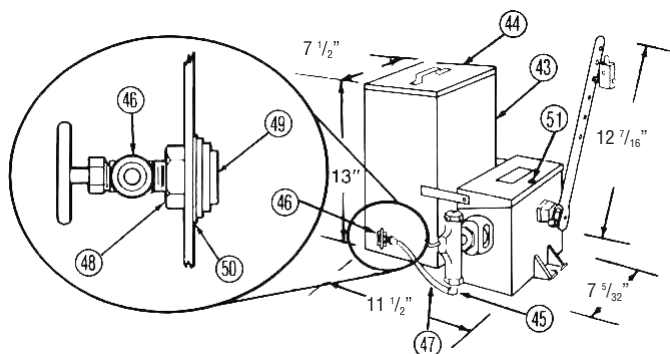

Beam Clamp Assembly
Item 42 (TA-700)

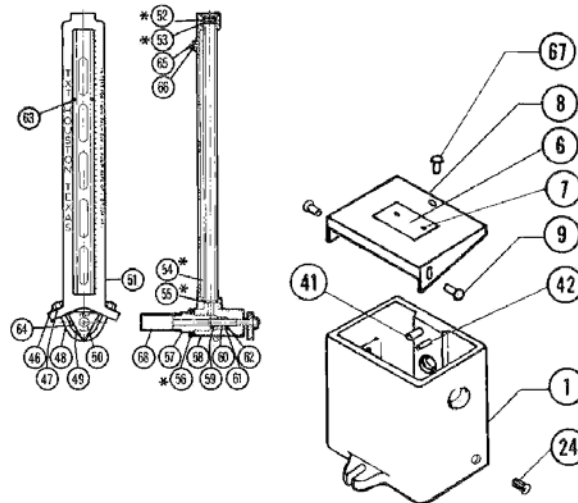
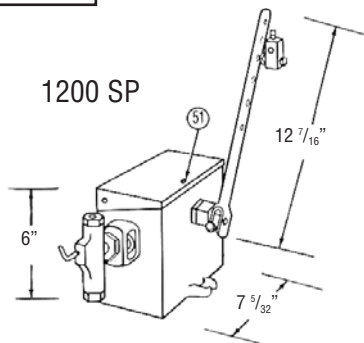

SERIES 1200 (Standard Box Assembly) PARTS LIST

Item	Part No.	Name	Item	Part No.	Name
1	TB-91	Box Ass'y	42	TA-985	Check Pawl Shaft
2*	TA-456	Pawl Spring (2 req'd.)	43	TA-458	Cut Washer
3*	TA-455	Pawl (2 req'd.)	44	TA-433	Ratchet Bearing Bolt
4	TA-536	Cross Head (simplex)	45	TA-420	Ratchet Sub Assembly
	TA-451	Cross Head (duplex)	46	TA-164	Nut
5	TA-434	Guide Plug Ass'y. (simplex only)	47	TA-577	Washer
6	GA-3181	Name Plate	48	TA-3106	U-Bolt
7	TA.171	Escutcheon Pin	49	TA-3112	Handle Valve
8	TA-960	LID	50	TA-164	Nut
9	TA-528	Rivet	51	TC-393	Frame
10	TA-438	Cap Screw	52	TA-3100	Spring
11	TA-452	Set Screw	53	TA-3101	Flat Washer
12	TA-409	Knuckle	54	TA-3102	Gauge Glass
13	TA-439	Nut	55	TA-2184	O-Ring
14	TB-67	Lever Arm	56	TA3199	O-Ring
15	TA.424	Lever Bolt	57	TA-3104	Retainer Nut
16	TA-425	Lock Washer	58	TA-3115	Valve Body
17	TA-144	Nut	59	TA-3114	Stem Valve
18	TA-4251	Nylon Washer	60	TA-3113	Spring
19*	TA-5200	Seal	61	TA-3328	Washer
20*	TA-5199	Shaft Bearing	62	TA-3107	O-Ring
21*	TB-66	Drive Shaft	63	TA-2163	O-Ring
22	TA-537	Ratchet Ass'y	64	TA-3329	Plug
23*	TA-290	Plunger Pin	65	TA-167	Washer
24	TA-138	Drain Plug	66	TA-166	Screw
*40	TA-457	Ratchet Bearing	67	TA-2577	Thumb Screw
41	TA-986	Check Pawl Spring Shaft	68	TA-3103	Strainer

TB-871
Tank Gauge
(Assembly for
five gallon SS tank)
*TB-0874 Repair
Kit Parts

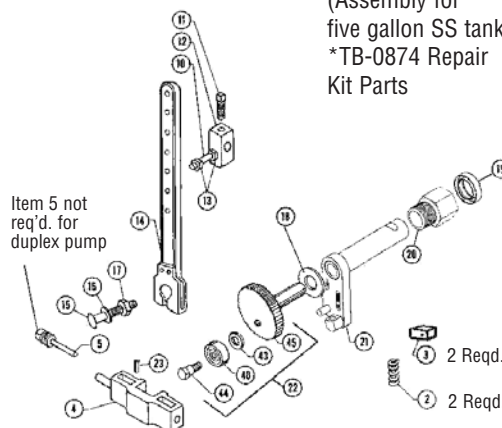

PARTS LIST

INJECTOR HEADS, SERIES 1200 PUMPS

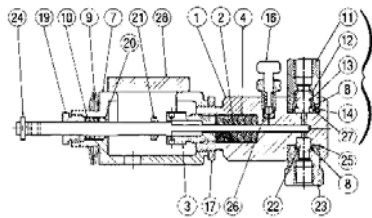

3/16" Head
Before 4-1-90

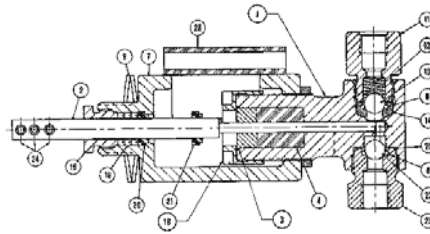
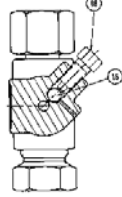

3/16" Head
After 4-1-90

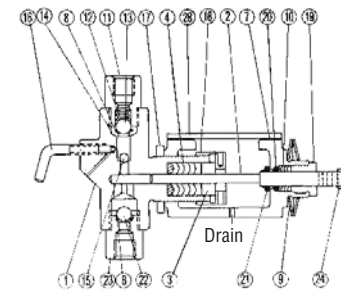

Note: Drip Ring Moves With the Plunger

1/4" - 3/8" - 1/2" Heads

Plunger Size			3/16"		1/4"		3/8"		1/2"	
Item No.	Material Specification	Material Construction	All Stainless Steel**	All Stainless Steel**	Ductile w/SS Trim	All Stainless Steel	Ductile w/SS Trim	All Stainless Steel	Ductile w/SS Trim	All Stainless Steel
			TC-1863	TC-2041	TC-1578	TC-1582	TC-1579	TC-1583	TC-1580	TC-1584
1	Body		TC-1588	TC-2040	TC-0275	TC-0291	TC-0276	TC-0425	TC-0272	TC-0349
2*	Plunger	17-4PH-SS	TB-1298	TB-1471	TB-1175	TB-1175	TB-1176	TB-1176	TB-1177	TB-1177
3	Plunger Packing Gland	303 SST	TA-4332	TA-5642	TA-1463	TA-1463	TA-0957	TA-0957	TA-1219	TA-1219
4*	Plunger Pcking Set (std.)	Buna-N	TA-3969	TA-3569	TA-1461	TA-1461	TA-1456	TA-1456	TA-0959	TA-0959
7	Yoke	Malleable Iron	TB-1173	TB-1173	TB-1173	TB-1173	TB-1173	TB-1173	TB-1173	TB-1173
8	O-Ring (included in item 23)	Buna_N	TA-0479	TA-0479	TA-0479	TA-0479	TA-0479	TA-0479	TA-0479	TA-0479
9	Belleville Washer (2 reqcd.)	C-Steel	TA-4256	TA-4256	TA-4256	TA-4256	TA-4256	TA-4256	TA-4256	TA-4256
10*	Yoke Packing Set	Buna-N	TA-4127	TA-4892	TA-4127	TA-4127	TA-4127	TA-4127	TA-4127	TA-4127
11	Top Bushing	302 SST	TA-4321	TA-1496	TA-1496	TA-1496	TA-1496	TA-1496	TA-1496	TA-1496
12*	Ball Check Spring	316 SST	TA-3427	TA-0077	TA-0077	TA-0077	TA-0077	TA-0077	TA-0077	TA-0077
13*	Large Top Ball 3/8"	316 SST	TA-0054	TA-0054	TA-0054	TA-0054	TA-0054	TA-0054	TA-0054	TA-0054
14*	Top-Seat Assy. w/Buna-N O-Ring	303 SST	TA-4322	TB-0737	TB-0737	TB-0737	TB-0737	TB-0737	TB-0737	TB-0737
15*	Small Top Ball 1/4"	316 SSst	NA	TA-0126	TA-0126	TA-0126	TA-0126	TA-0126	TA-0126	TA-0126
16	Priming Valve (Ball & Spring incl. 3/16")	303 SST	TA-4027	TA-5462	TA-1497	TA-1497	TA-1497	TA-1497	TA-1497	TA-1497
17	Lock Nut Yoke	Brass	TA-0225	TA-0225	TA-0225	TA-0225	TA-0225	TA-0225	TA-0225	TA-0225
18	Nut, Plunger Packing Gland	303 SST	NA.	TA-4104	TA-4104	TA-4104	TA-4104	TA-4104	TA-4104	TA-4104
19	Nut, Yoke Packing	Brass	TA-4094	TA-4094	TA-4094	TA-4094	TA-4094	TA-4094	TA-4094	TA-4094
22*	Ball, Suction 3/8"	316 SST	TA-4095	TA-4095	TA-4095	TA-4095	TA-4095	TA-4095	TA-4095	TA-4095
20*	Wiper Ring, Plunger	Buna-N	TA-4095	TA-4095	TA-4095	TA-4095	TA-4095	TA-4095	TA-4095	TA-4095
21	Drip-Ring Plunger	Buna-N	TA-0054	TA-0054	TA-0054	TA-0054	TA-0054	TA-0054	TA-0054	TA-0054
23*	Bottom Seat (w/Buna-N O-Ring)	303 SST	TB-1216	TB-1216	TB-0736	TB-0736	TB-0736	TB-0736	TB-0736	TB-0736
24	Pin Plugger	Carbon Steel	TA-0290	TA-0290	TA-0290	TA-0290	TA-0290	TA-0290	TA-0290	TA-0290
25	Gasket	304 SST	TA-4394	TA-4394			Not Applicable			
26*	O-Ring	Buna-N	TA-0759	NA			Not Applicable			
27*	O-Ring	Buna-N	TA_2116				Not Applicable			
28	Yoke Cover	Plastic	TC-1604	TC-1604	TC-1604	TC-1604	TC-1604	TC-1604	TC-1604	TC-1604
Alternate Parts for Corrosive Service										
4*	Plunger Packing	Viton	TA-3967	TA-3967	TA-4102	TA-4102	TA-4101	TA-4101	TA-4103	TA-4103
		Teflon	TA-3966	TA-3966	TA-1642	TA-1642	TA-1234	TA-1234	TA-1012	TA-1012
		Hard	TA-3948	TA-3948	TA-2295	TA-2295	TA-1875	TA-1875	TA-1874	TA-1874
8*	O-Ring	Viton	TA-2580	TA-2580	TA-2580	TA-2580	TA-2580	TA-2580	TA-2580	TA-2580
14*	Top Seat Assem. (Metal-to-Metal)	303 SST	NA	NA	TA-0806	TA-0806	TA-0806	TA-0806	TA-0806	TA-0806
22	Ball 1/2" (use w/TA-0771, Metal-to-Metal Bottom Seat only)	316 SST	NA	NA	TA-0053	TA-0053	TA-0053	TA-0053	TA-0053	TA-0053
23*	Bottom Seat (Metal-to-Metal)	NA	NA	TA-0771	TA-0771	TA-0771	TA-0771	TA-0771	TA-0771	TA-0771
27*	O-Ring	Viton	TA-5106	NA	NA	NA	NA	NA	NA	NA

*Recommended Spare Parts

** Ductile Not Available before 4-1-90



Dresser Industrial Products Group

16240 Port Northwest Drive
Houston, Texas 77041-2645

Phone: 832.590.2306

Fax: 713.849.2879

www.dresser.com