

Husky[®] 1050 Air-Operated Diaphragm Pump

313435S

EN

**1-inch pump with modular air valve for fluid transfer applications.
For professional use only.**

See page 4 for model information, including approvals.

125 psi (0.86 MPa, 8.6 bar) Maximum Fluid Working Pressure
125 psi (0.86 MPa, 8.6 bar) Maximum Air Input Pressure



Important Safety Instructions

Read all warnings and instructions in this manual.
Save these instructions.

1050P Polypropylene
1050C Conductive Polypropylene
1050F PVDF

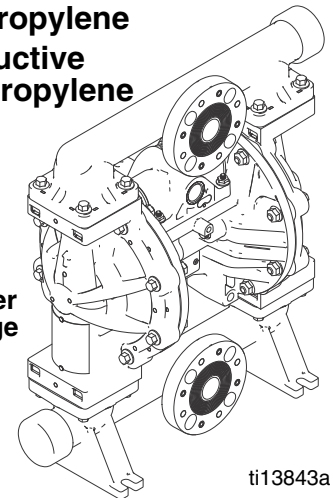

Center Flange

ti13843a

1050A Aluminum

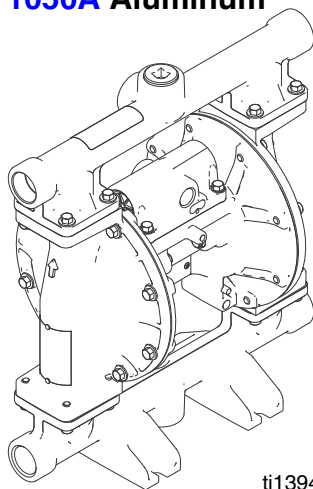

ti13946a

1050S Stainless Steel
1050H Hastelloy

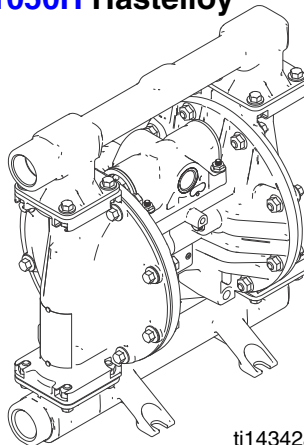

ti14342a

End Flange

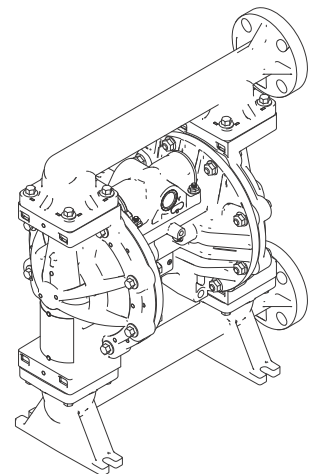

ti13844a



Contents

Related Manuals	2	Parts	20
To Find Your Nearest Distributor	3	Parts/Kits Quick Reference	21
To Specify the Configuration of a New Pump	3	Center Section	22
To Order Replacement Parts	3	Air Valve and Data Monitoring	24
Distributor Note	3	Fluid Covers and Manifolds	26
Pump Matrix	4	Seats and Check Ball	28
ATEX Certifications	5	Diaphragms	29
Warnings	5	Manifold O-Rings	31
Troubleshooting	8	DataTrak	31
Repair	10	Accessories	31
Pressure Relief Procedure	10	Technical Data	32
Repair or Replace Air Valve	10	Graco Standard Husky Pump Warranty	34
DataTrak	13	Graco Information	34
Check Valve Repair	14		
Diaphragms and Center Section	15		
Torque Instructions	18		

Related Manuals

Manual	Description
312877	Husky 1050 Air-Operated Diaphragm Pump, Operation
313597	Husky 1050A UL-Listed Diaphragm Pump, Operation
313840	DataTrak, Instructions/Parts
406824	Pulse Count Kits, Instructions
406825	Reed Switch with Solenoid Kits, Instructions
406826	Torque Instructions (Manifolds and Fluid Covers)

To Find Your Nearest Distributor

1. Visit www.graco.com.
2. Click on **Where to Buy** and use the **Distributor Locator**.

To Specify the Configuration of a New Pump

Please call your distributor.

OR

1. Use the **Online Husky Selector Tool** at wwwd.graco.com/training/husky/index.html.
2. If the link does not work, you will find the selector tool on the **Process Equipment** page at www.graco.com.

To Order Replacement Parts

Please call your distributor.

Distributor Note

1. To find part numbers for new pumps or kits, use the **Online Husky Selector Tool**.
2. To find part numbers for replacement parts:
 - a. Use the 20-digit number from the ID plate on the pump. If you only have the Graco 6-digit part number, use the selector tool to find the corresponding 20-digit number.
 - b. Use the Configuration Number Matrix on the next page to understand which parts are described by each digit.
 - c. Refer to the main **Parts** illustration and to the **Parts/Kits Quick Reference**. Follow the page references on these two pages for further ordering information, as needed.
3. Please call Graco Customer Service to order.

Pump Matrix

Check the identification plate (ID) for the 20-digit Configuration Number of your pump. Use the following matrix to define the components of your pump.

Sample Configuration Number

1050A	A01A	A1	SS	BN	BN	PT
Pump Model	Center Section and Air Valve	Fluid Covers and Manifolds	Seats	Balls	Diaphragms	Manifold O-Rings

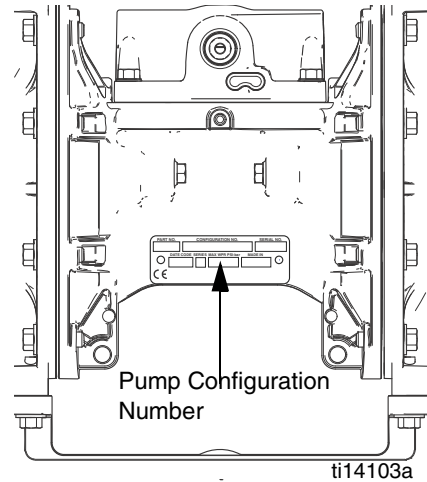

Pump Model (1 inch ports, 50 gpm)	Center Section and Air Valve Material	Air Valve/Monitoring		Fluid Covers and Manifolds	
1050A ★ Aluminum	Aluminum	A01A	Standard	A1	Aluminum, standard ports, inch
		A01B	Pulse Count✘	A2	Aluminum, standard ports, metric
		A01C	DataTrak✘	C1	Conductive polypropylene, center flange
		A01D	Remote	C2	Conductive polypropylene, end flange
		A01E	Optional FKM Seals	F1	PVDF, center flange
1050F PVDF	Conductive Polypropylene	C01A	Standard	F2	PVDF, end flange
		C01B	Pulse Count✘	H1	Hastelloy, standard ports, inch
		C01C	DataTrak✘	H2	Hastelloy, standard ports, metric
		C01D	Remote	P1	Polypropylene, center flange
1050H ‡ Hastelloy	Polypropylene	P01A	Standard	P2	Polypropylene, end flange
		P01B	Pulse Count✘	S1	Stainless steel, standard ports, inch
		P01C	DataTrak✘	S2	Stainless steel, standard ports, metric
		P01D	Remote		
1050P Polypropylene	Polypropylene				
1050S ‡ Stainless Steel					
★, ‡, or ✘: See ATEX Certifications, on page 5.					

Check Valve Seats		Check Valve Balls		Diaphragm		Manifold O-Rings	
AC	Acetal	AC	Acetal	BN	Buna-N	—	Models with Buna-N, FKM Fluoroelastomer or TPE seats do not use o-rings.
AL	Aluminum	BN	Buna-N	CO	Polychloroprene Overmolded		
BN	Buna-N	CR	Polychloroprene Standard	FK	FKM Fluoroelastomer		
FK	FKM Fluoroelastomer	CW	Polychloroprene Weighted	GE	Geolast		
GE	Geolast®	FK	FKM Fluoroelastomer	PO	PTFE/EPDM Overmolded		
PP	Polypropylene	GE	Geolast	PT	PTFE/EPDM Two-Piece		
PV	PVDF	PT	PTFE	SP	Santoprene		
SP	Santoprene®	SP	Santoprene	TP	TPE		
SS	316 Stainless Steel	SS	316 Stainless Steel				
TP	TPE	TP	TPE				
						PT	PTFE

ATEX Certifications

★ All **1050A** (Aluminum) and **1050C** (Conductive Polypropylene) pumps are certified:

 II 2 GD c IIC T4

‡ **1050S** (Stainless Steel) and **1050H** (Hastelloy) pumps with aluminum or conductive polypropylene centers are certified:

 II 2 GD c IIC T4







✱ **DataTrak** and **Pulse Count** are certified:

Intertek
9902471
Class I, Div. 1,
Group D T3A





 0359  II 1 G
Ex ia IIA T3 Ga
ITS13ATEX27862X

Warnings





The following warnings are for the setup, use, grounding, maintenance, and repair of this equipment. The exclamation point symbol alerts you to a general warning and the hazard symbol refers to procedure-specific risk. When these symbols appear in the body of this manual, refer back to these Warnings. Additional, product-specific warnings may be found throughout the body of this manual where applicable.

 WARNING	
    	<p>FIRE AND EXPLOSION HAZARD</p> <p>Flammable fumes, such as solvent and paint fumes, in work area can ignite or explode. To help prevent fire and explosion:</p> <ul style="list-style-type: none"> • Use equipment only in well ventilated area. • Eliminate all ignition sources; such as pilot lights, cigarettes, portable electric lamps, and plastic drop cloths (potential static arc). • Keep work area free of debris, including solvent, rags and gasoline. • Do not plug or unplug power cords, or turn power or light switches on or off when flammable fumes are present. • Ground all equipment in the work area. See Grounding instructions. • Use only grounded hoses. • Hold gun firmly to side of grounded pail when triggering into pail. • If there is static sparking or you feel a shock, stop operation immediately. Do not use equipment until you identify and correct the problem. • Keep a working fire extinguisher in the work area. <p>Static charge may build up on plastic parts during cleaning and could discharge and ignite flammable materials and gases. To help prevent fire and explosion:</p> <ul style="list-style-type: none"> • Clean plastic parts in a well ventilated area. • Do not clean with a dry cloth. • Do not operate electrostatic guns in equipment work area.



WARNING

	<p>EQUIPMENT MISUSE HAZARD</p> <p>Misuse can cause death or serious injury.</p> <ul style="list-style-type: none"> • Do not operate the unit when fatigued or under the influence of drugs or alcohol. • Do not exceed the maximum working pressure or temperature rating of the lowest rated system component. See Technical Data in all equipment manuals. • Use fluids and solvents that are compatible with equipment wetted parts. See Technical Data in all equipment manuals. Read fluid and solvent manufacturer's warnings. For complete information about your material, request MSDS from distributor or retailer. • Do not leave the work area while equipment is energized or under pressure. Turn off all equipment and follow the Pressure Relief Procedure in this manual when equipment is not in use. • Check equipment daily. Repair or replace worn or damaged parts immediately with genuine manufacturer's replacement parts only. • Do not alter or modify equipment. • Use equipment only for its intended purpose. Call your distributor for information. • Route hoses and cables away from traffic areas, sharp edges, moving parts, and hot surfaces. • Do not kink or over bend hoses or use hoses to pull equipment. • Keep children and animals away from work area. • Comply with all applicable safety regulations.
	<p>PRESSURIZED EQUIPMENT HAZARD</p> <p>Fluid from the gun/dispense valve, leaks, or ruptured components can splash in the eyes or on skin and cause serious injury.</p> <ul style="list-style-type: none"> • Follow Pressure Relief Procedure in this manual, when you stop spraying and before cleaning, checking, or servicing equipment. • Tighten all fluid connections before operating the equipment. • Check hoses, tubes, and couplings daily. Replace worn or damaged parts immediately.
	<p>THERMAL EXPANSION HAZARD</p> <p>Fluids subjected to heat in confined spaces, including hoses, can create a rapid rise in pressure due to the thermal expansion. Over-pressurization can result in equipment rupture and serious injury.</p> <ul style="list-style-type: none"> • Open a valve to relieve the fluid expansion during heating. • Replace hoses proactively at regular intervals based on your operating conditions.
	<p>PRESSURIZED ALUMINUM PARTS HAZARD</p> <p>Use of fluids that are incompatible with aluminum in pressurized equipment can cause serious chemical reaction and equipment rupture. Failure to follow this warning can result in death, serious injury, or property damage.</p> <ul style="list-style-type: none"> • Do not use 1,1,1-trichloroethane, methylene chloride, other halogenated hydrocarbon solvents or fluids containing such solvents. • Many other fluids may contain chemicals that can react with aluminum. Contact your material supplier for compatibility.
	<p>PLASTIC PARTS CLEANING SOLVENT HAZARD</p> <p>Use only compatible water-based solvents to clean plastic structural or pressure-containing parts. Many solvents can degrade plastic parts and cause them to fail, which could cause serious injury or property damage. See Technical Data in this and all other equipment instruction manuals. Read fluid and solvent manufacturer's warnings.</p>

 **WARNING**

 	<p>TOXIC FLUID OR FUMES HAZARD</p> <p>Toxic fluids or fumes can cause serious injury or death if splashed in the eyes or on skin, inhaled, or swallowed.</p> <ul style="list-style-type: none"> • Read MSDS's to know the specific hazards of the fluids you are using. • Route exhaust away from work area. If diaphragm ruptures, fluid may be exhausted with air. • Store hazardous fluid in approved containers, and dispose of it according to applicable guidelines.
	<p>BURN HAZARD</p> <p>Equipment surfaces and fluid that's heated can become very hot during operation. To avoid severe burns:</p> <ul style="list-style-type: none"> • Do not touch hot fluid or equipment.
	<p>PERSONAL PROTECTIVE EQUIPMENT</p> <p>You must wear appropriate protective equipment when operating, servicing, or when in the operating area of the equipment to help protect you from serious injury, including eye injury, inhalation of toxic fumes, burns, and hearing loss. This equipment includes but is not limited to:</p> <ul style="list-style-type: none"> • Clothing and respirator as recommended by the fluid and solvent manufacturer • Protective eyewear, gloves, and hearing protection.

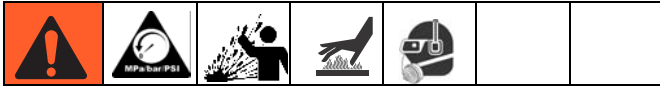
Troubleshooting



Problem	Cause	Solution
Pump cycles but will not prime.	Pump is running too fast, causing cavitation before prime	Lower air inlet pressure.
	Check valve ball severely worn or wedged in seat or manifold.	Replace ball and seat. See page 14.
	Seat severely worn.	Replace ball and seat. See page 14.
	Outlet or inlet clogged.	Unclog.
	Inlet or outlet valve closed.	Open.
	Inlet fittings or manifolds loose.	Tighten.
	Manifold o-rings damaged.	Replace o-rings. See page 14.
Pump cycles at stall or fails to hold pressure at stall.	Worn check valve balls, seats, or o-rings.	Replace. See page 28.
Pump will not cycle, or cycles once and stops.	Air valve is stuck or dirty.	Disassemble and clean air valve. See page 11. Use filtered air.
	Check valve ball severely worn and wedged in seat or manifold.	Replace ball and seat. See page 14.
	Pilot valve worn, damaged, or plugged.	Replace pilot valve. See page 15.
	Air valve gasket damaged.	Replace gasket. See page 10.
	Check valve ball is wedged into seat due to overpressurization.	Install pressure relief kit. See Accessories , page 31.
	Dispensing valve clogged.	Relieve pressure and clear valve.
	Air tubing is plugged (remote air control models).	Clear tube.
Pump operates erratically.	Clogged suction line.	Inspect; clear.
	Sticky or leaking check valve balls.	Clean or replace. See page 14.
	Diaphragm (and backup) ruptured.	Replace. See page 15.
	Restricted exhaust.	Remove restriction.
	Pilot valves damaged or worn.	Replace pilot valves. See page 15.
	Air valve damaged.	Replace air valve. See page 10.
	Air valve gasket damaged.	Replace air valve gasket. See page 10.
	Air supply erratic.	Repair air supply.
Exhaust muffler icing.	Use drier air supply or use low ice muffler (Graco part 102656).	

Problem	Cause	Solution
Air bubbles in fluid.	Suction line is loose.	Tighten.
	Diaphragm (and backup) ruptured.	Replace. See page 15.
	Loose manifolds, damaged seats or manifold o-rings.	Tighten manifold bolts or replace seats or o-rings. See page 14.
	Diaphragm shaft bolt o-ring damaged.	Replace o-ring.
	Pump cavitation.	Reduce pump speed or suction lift.
	Loose diaphragm shaft bolt.	Tighten.
Exhaust air contains fluid being pumped.	Diaphragm (and backup) ruptured.	Replace. See page 15.
	Loose diaphragm shaft bolt.	Tighten or replace. See page 15.
	Diaphragm shaft bolt o-ring damaged.	Replace o-ring. See page 15.
Moisture in exhaust air.	High inlet air humidity.	Use drier air supply.
Pump exhausts excessive air at stall.	Worn air valve cup or plate.	Replace cup and plate. See page 11.
	Damaged air valve gasket.	Replace gasket. See page 10.
	Damaged pilot valve.	Replace pilot valves. See page 15.
	Worn shaft seals or bearings.	Replace shaft seals or bearings. See page 15.
	Air tubing is damaged or loose (remote air control models).	Replace tubing or secure connection.
	Remote air pressure is higher than pump air pressure (remote air control models).	Regulate remote pilot air pressure to be equal to or less than main air.
Pump leaks air externally.	Air valve or fluid cover screws loose.	Tighten.
	Diaphragm damaged.	Replace diaphragm. See page 15.
	Air valve gasket damaged.	Replace gasket. See page 10.
	Remote air pressure is higher than pump air pressure (remote air control models).	Regulate remote pilot air pressure to be equal to or less than main air.
Pump leaks fluid externally from joints.	Loose manifold screws or fluid cover screws.	Tighten manifold screws or fluid cover screws. See page 18.
	Manifold o-rings worn out.	Replace o-rings. See page 14.
Pump leaks fluid externally through manifold or fluid cover.	Excessive pump speed or inlet starvation.	Replace manifold and reduce pump speed or improve pump feed.

Repair

! WARNING



SPECIAL CONDITIONS FOR SAFE USE

Equipment must comply with the following conditions to avoid a hazardous condition which can cause fire or explosion.

- All label and marking material must be cleaned with a damp cloth (or equivalent).
- The electronic monitoring system is required to be grounded. See **Grounding** instructions in your pump operation manual.

Pressure Relief Procedure

!

MPa bar PSI

!

!

!

!

!

Trapped air can cause the pump to cycle unexpectedly, which could result in serious injury from splashing.

1. Shut off the air supply to the pump.
2. Open the dispensing valve, if used.
3. Open the fluid drain valve to relieve fluid pressure. Have a container ready to catch the drainage.

Repair or Replace Air Valve

!

MPa bar PSI

!

!

!

!

!

Replace Complete Air Valve

1. Stop the pump. Relieve the pressure. See **Pressure Relief Procedure** in previous section.
2. Disconnect the air line to the motor.
3. **For motors with Pulse Count or DataTrak:** Remove screw to disconnect the reed switch assembly from the air valve.

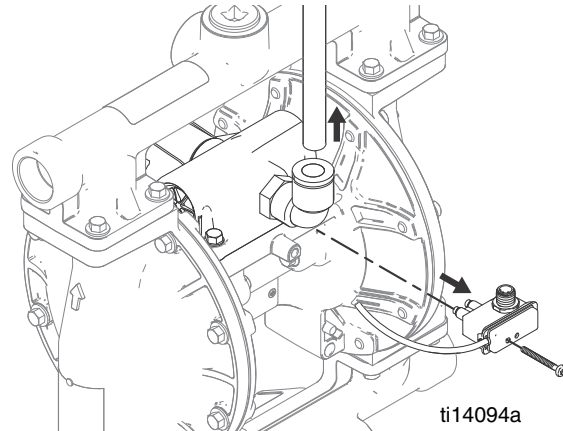

FIG. 1. Reed switch assembly and air line removal

4. **For motors with DataTrak:** Remove two screws and the solenoid bracket. Pull the solenoid out of the air valve.

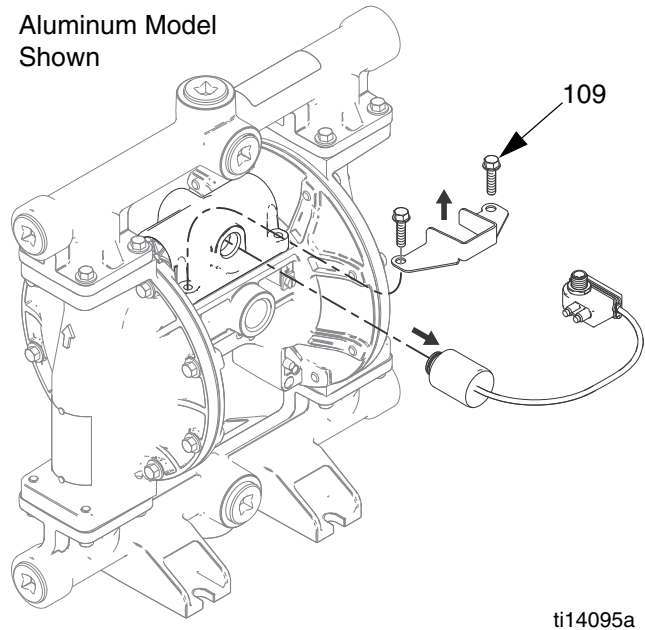

FIG. 2. Solenoid removal

5. Remove screws (109, metal pumps) or nuts (112, plastic pumps). Remove the air valve and gasket (108).
6. To repair the air valve, go to **Disassemble the Air Valve**, step 1, in next section. To install a replacement air valve, continue with step 7.
7. Align the new air valve gasket (108) on the center housing, then attach the air valve. See **Torque Instructions**, page 18.

8. **For motors with DataTrak:** Remember to reattach the solenoid bracket and the solenoid.
9. **For motors with Pulse Count or DataTrak:** Use screw to attach the reed switch assembly to the new air valve. Reconnect cable.
10. Reconnect the air line to the motor.

Replace Seals or Rebuild Air Valve

NOTE: Repair kits are available. See page 25 to order the correct kit(s) for your pump. Air Valve Seal Kit parts are marked with a †. Air Valve Repair Kit parts are marked with a ◆. Air Valve End Cap Kit parts are marked with a ⌘.

Disassemble the Air Valve

1. Perform steps 1-5 under **Replace Complete Air Valve**, page 10.
2. See FIG. 4. Use a Torx screwdriver (T8 for aluminum centers, T9 for plastic centers) to remove two screws (209). Remove the valve plate (205), cup assembly (212-214), spring (211), and detent assembly (203).
3. Pull the cup (213) off of the base (212). Remove the o-ring (214) from the cup.
4. See FIG. 4. Remove the retaining ring (210) from each end of the air valve. Use the piston (202) to push the end caps (207, 217) out of the ends. Remove end cap o-rings (206). If pump model is equipped with a runaway protection solenoid, also remove the solenoid release button (218) and o-ring (219).
5. Remove the u-cup seals (208) from each end of the piston (202), then remove the piston. Remove the detent cam (204) from the air valve housing (201).

Reassemble the Air Valve

NOTE: Apply lithium-based grease whenever instructed to grease.

1. Use all parts in the repair kits. Clean other parts and inspect for damage. Replace as needed.
2. Grease the detent cam (204) and install into housing (201).
3. Grease the u-cups (208) and install on the piston with lips facing toward the center of the piston.

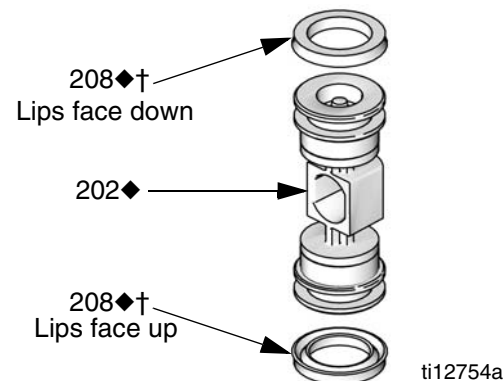

FIG. 3. Air valve u-cup installation

4. Grease both ends of the piston (202) and install it in the housing (201), with the flat side toward the cup (212). Be careful not to tear u-cups (208) when sliding piston into housing.
5. **Standard or Pulse Count models (no runaway protection solenoid):** Grease new o-rings (206) and install on the end caps (207). Install the end caps into the housing.
DataTrak models (with runaway protection solenoid): Orient the air valve so the air inlet faces forward. Grease and install new o-ring (206) on right-side end cap (207). Grease and install new o-ring (206) and the solenoid release button (218) and o-ring (219) on left-side end cap (217). Install the end caps into the housing.
6. Install a retaining ring (210) on each end to hold end caps in place.

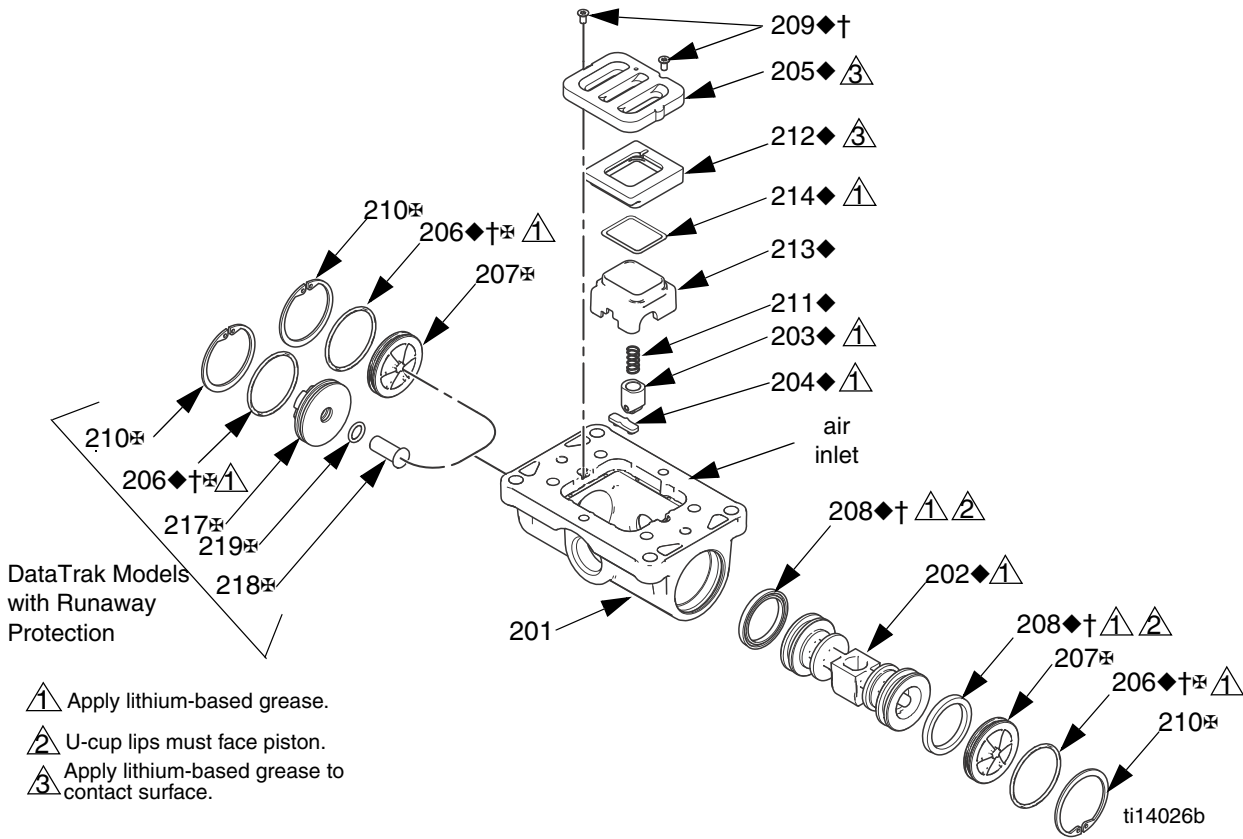

FIG. 4. Air valve assembly

- Grease and install the detent assembly (203) into the piston. Install the o-ring (214) on the cup (213). Apply a light film of grease to the outside surface of the o-ring and the inside mating surface of the base (212).

Orient the end of the base that has a magnet toward the end of the cup that has the larger cutout. Engage the opposite end of the parts. Leave the end with the magnet free. Tilt the base toward the cup and fully engage the parts, using care so that the o-ring remains in place. Install the spring (211) onto the protrusion on the cup. Align the magnet in the base with the air inlet and install the cup assembly.

- Grease the cup side and install the valve plate (205). Align the small hole in the plate with the air inlet. Tighten the screws (209) to hold it in place.

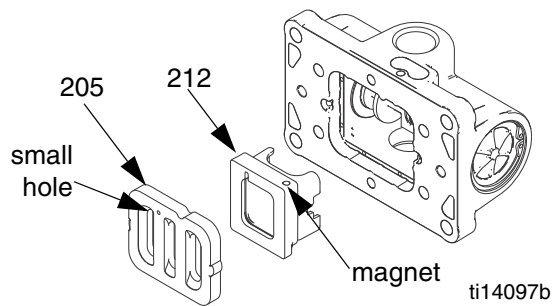

FIG. 6. Air valve cup and plate installation

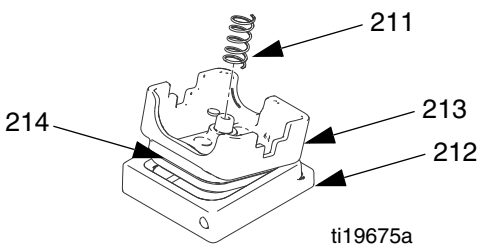



FIG. 5

DataTrak

NOTE: See DataTrak manual, 313840, for all DataTrak service and repair information.

Replace DataTrak Battery or Fuse

 WARNING	
	<p>To reduce the risk of fire and explosion, the battery and fuse must be replaced in a non-hazardous location. Follow all instructions in your pump operation manual.</p> <p>Use only an approved replacement battery, and an approved fuse (see pump operation manual). Use of an unapproved battery or fuse will void Graco's warranty and Intertek and Ex approvals.</p>

Check Valve Repair



NOTE: Kits are available for new check valve balls and seats in a range of materials. See page 28 to order kits in the material(s) desired. An o-ring kit and fastener kits also are available.

NOTE: To ensure proper seating of the check balls, always replace the seats when replacing the balls. Also, on models with manifold o-rings, replace the o-rings.

Disassembly

1. Follow the **Pressure Relief Procedure** on page 10. Disconnect all hoses.
2. Remove the pump from its mounting.

NOTE: For plastic pumps (**1050P**, **1050C**, and **1050F**), use hand tools only until thread-locking adhesive patch releases.

3. Use a 10 mm socket wrench to remove the outlet manifold fasteners (6). See FIG. 7.
4. Remove the o-rings (12, *not used on some models*), seats (10), and balls (11).
5. Turn the pump over and remove the inlet manifold. Remove the o-rings (12, *not used on some models*), seats (10), and balls (11).

Reassembly

1. Clean all parts and inspect for wear or damage. Replace parts as needed.
2. Reassemble in the reverse order, following all notes in FIG. 7. Be sure the ball checks (10-12) and manifolds (4, 5) are assembled **exactly** as shown. The arrows (A) on the fluid covers **must** point toward the outlet manifold (4).

- ⚠ 1 Torque to 100 in-lb (11.3 N•m). See **Torque Instructions**, page 18.
- ⚠ 2 Arrow (A) must point toward outlet manifold.
- ⚠ 3 Not used on some models.

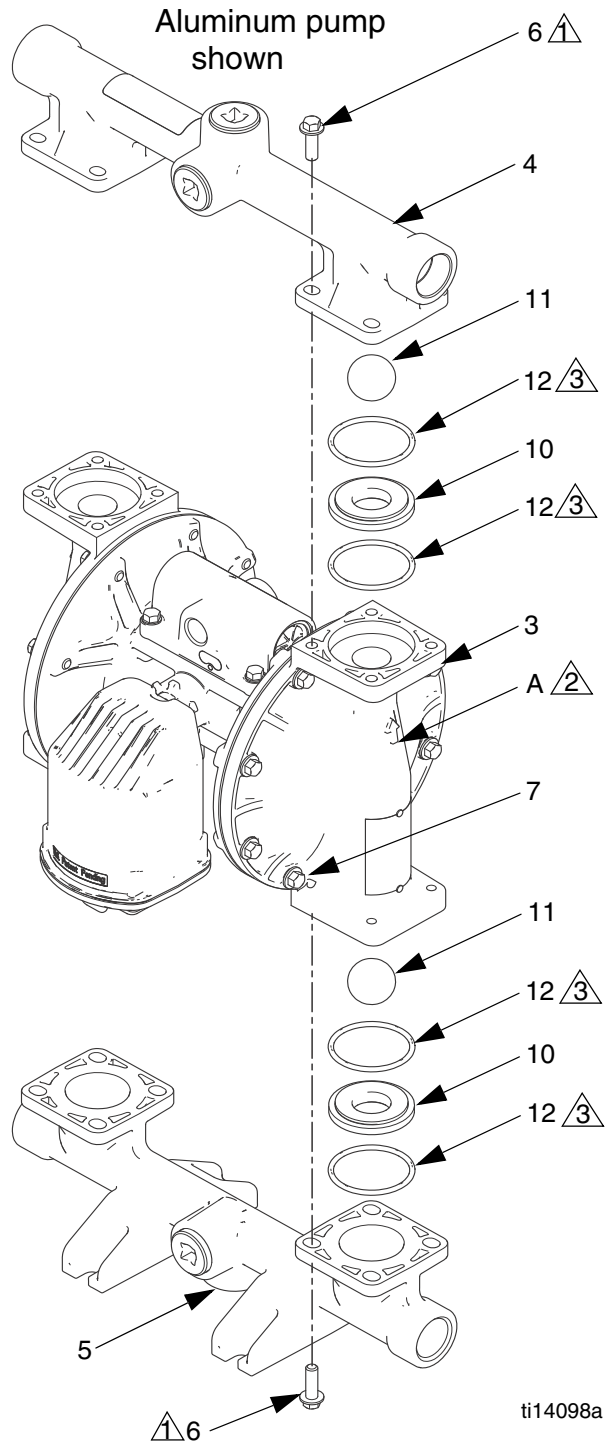

ti14098a

FIG. 7. Ball check valve assembly

Diaphragms and Center Section



Disassembly

NOTE: Diaphragm kits are available in a range of materials and styles. See page 29 to order the correct diaphragms for your pump. A Center Rebuild Kit also is available. See page 23. Parts included in the Center Rebuild Kit are marked with an *. For best results, use all kit parts.

1. Follow the **Pressure Relief Procedure** on page 10.

2. Remove the manifolds and disassemble the ball check valves as explained on page 14.

3. Overmolded Diaphragms

- Orient the pump so one of the fluid covers faces up. Use a 10 mm socket wrench to remove the fluid cover screws (7), then pull the fluid cover (3) up off the pump.
- The exposed diaphragm (15) will screw off by hand from the diaphragm shaft (104). The diaphragm shaft bolt will remain attached to the diaphragm. Remove the air side diaphragm plate (14).
- Turn the pump over and remove the other fluid cover. Pull the diaphragm and shaft up through the center housing.
- Grasp the diaphragm firmly and use a wrench on the flats of the shaft to remove. Also remove the air side diaphragm plate (14). Continue with Step 5.

4. All Other Diaphragms

- Orient the pump so one of the fluid covers faces up. Use a 10 mm socket wrench to remove the fluid cover screws (7), then pull the fluid cover up off the pump. Turn the pump over and remove the other fluid cover.

b. **Plastic Pumps:** Use a 1-1/4 socket or box end wrench on the hex of a fluid side diaphragm plate to remove. Then remove all parts of the diaphragm assembly. See FIG. 8.

Metal Pumps: Remove the bolt (304) from one side of the diaphragm shaft, then remove all parts of that diaphragm assembly. See FIG. 8.

c. Follow the same procedure to disassemble the other diaphragm assembly.

5. Inspect the diaphragm shaft (104) for wear or scratches. If it is damaged, inspect the bearings (105) in place. If they are damaged, use a bearing puller to remove them.

NOTE: Do not remove undamaged bearings.

6. Use an o-ring pick to remove the u-cup packings (106) from the center housing. Bearings (105) can remain in place.

7. If necessary, use a socket wrench to remove the pilot valves (101) or pilot inserts (113, remote air control models).

8. Remove the pilot valve cartridges only if necessary due to a known or suspected problem. **After removing pilot valves**, use a hex to remove the cartridges (102), then remove cartridge o-rings (103). If stripped, use two screwdrivers to screw out the cartridge.

NOTE: Do not remove undamaged pilot valve cartridges.

Repair

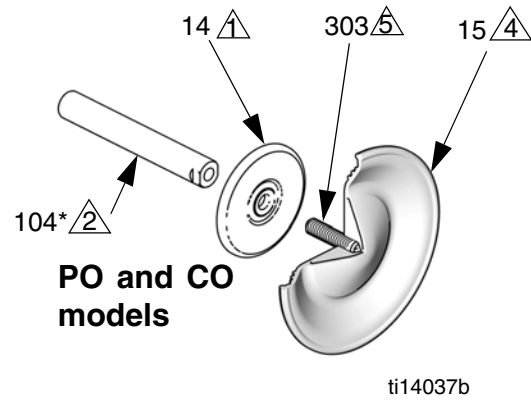
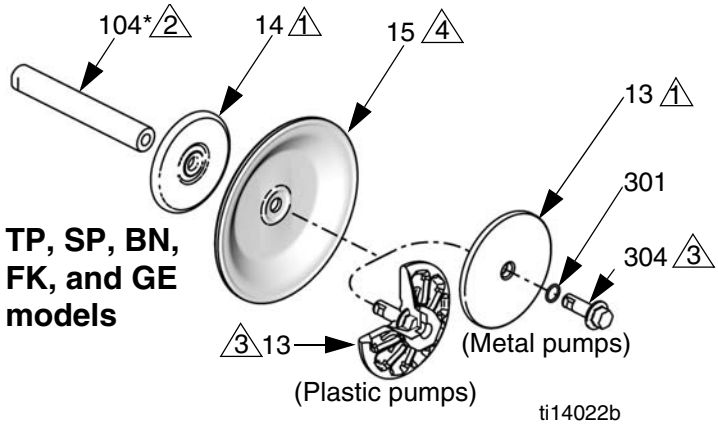

△ Rounded side faces diaphragm.

△ Apply lithium-based grease.

△ Torque to 20-25 ft-lb (27-34 N•m) at 100 rpm maximum.

△ AIR SIDE markings on diaphragm must face center housing.

△ If screw comes loose or is replaced, apply permanent (red) Loctite® or equivalent to diaphragm side threads. Apply primer and medium-strength (blue) Loctite® or equivalent to shaft side threads.

△ Lips must face out of housing.

△ Cartridges (102) must be installed before pilot valves (101) or inserts (113, for remote air controls).

△ Torque to 20-25 in.-lb (2.3-2.8 N•m).

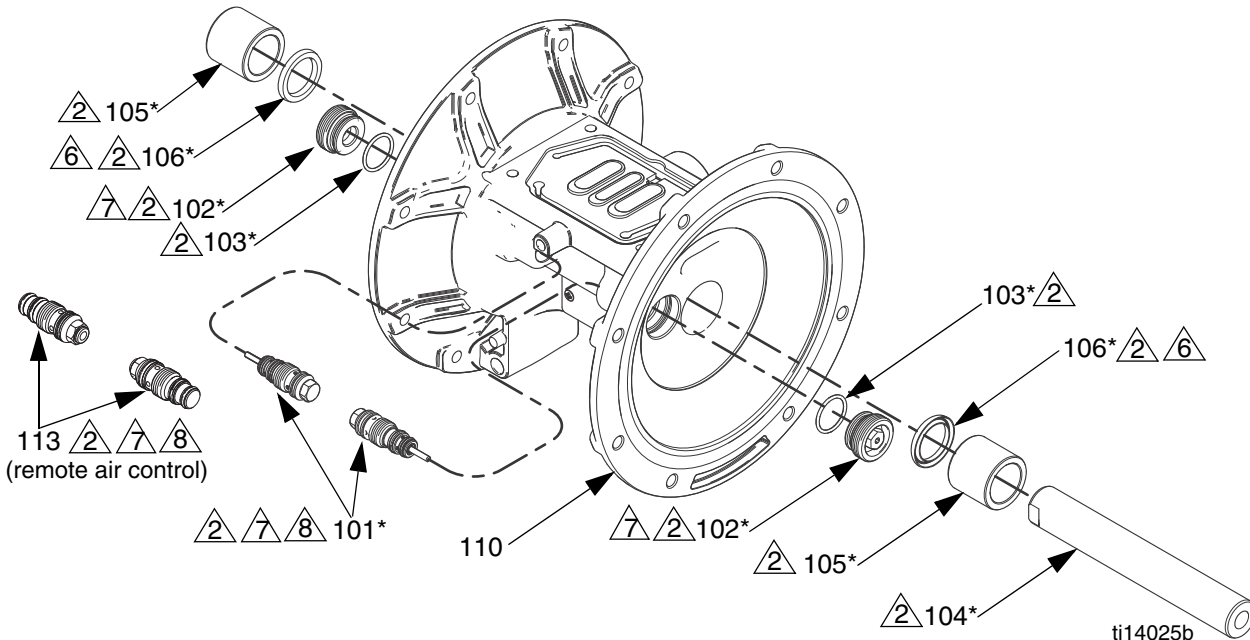
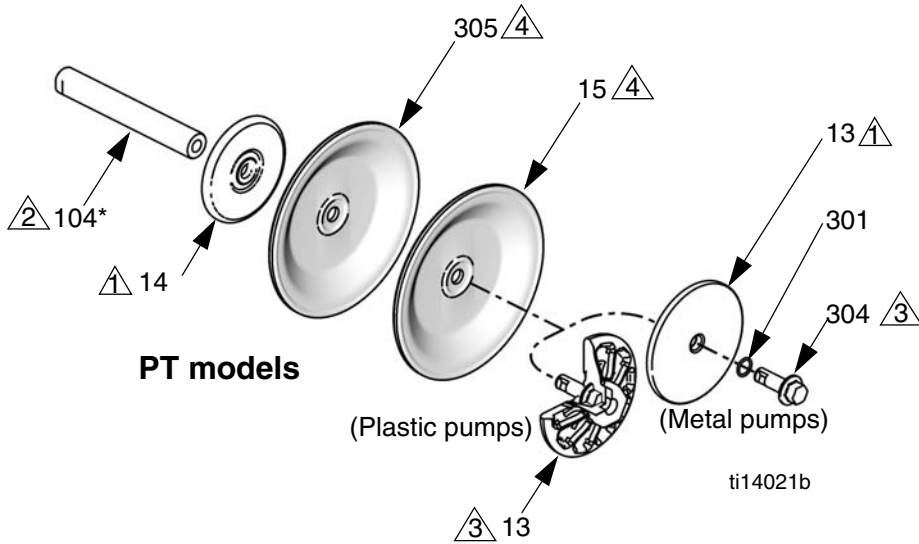

Fig. 8. Assemble diaphragms and center section

Reassembly

Follow all notes in FIG. 8. These notes contain **important** information.

NOTE: Apply lithium-based grease whenever instructed to grease.

1. Clean all parts and inspect for wear or damage. Replace parts as needed.
2. If removed, grease and install the new pilot valve cartridges (102) and cartridge o-rings (103). Screw in until seated.

NOTE: Cartridges (102) *must* be installed before pilot valves (101).

3. Grease and install the pilot valves (101). Torque to 20-25 in.-lb (2.3-2.8 N•m). Do not over-torque.
4. Grease and install the diaphragm shaft u-cup packings (106) so the lips face **out** of the housing.
5. If removed, insert the new bearings (105) into the center housing. Use a press or a block and rubber mallet to press-fit the bearing so it is flush with the surface of the center housing.

6. Overmolded Diaphragms:

- a. Clamp the shaft flats in a vise.
- b. If diaphragm setscrew comes loose or is replaced, apply permanent (red) Loctite® or equivalent to diaphragm side threads. Screw into diaphragm until tight.
- c. Assemble the air side plate (14) onto the diaphragm. The rounded side of the plate must face the diaphragm.
- d. Apply medium-strength (blue) Loctite or equivalent to the threads of the diaphragm assembly. Screw the assembly into the shaft as tight as possible by hand.
- e. Grease the shaft u-cups (106) and the length and ends of the diaphragm shaft (104). Slide the shaft into the housing.
- f. Reattach the first fluid cover (3). See **Torque Instructions**, page 18.
- g. Repeat Steps b and c for the other diaphragm assembly. Go to Step 7.

All Other Diaphragms - Metal Pumps:

- a. Install the o-ring (301) on the shaft bolt (304).
- b. Assemble the fluid side plate (13), the diaphragm (15), the backup diaphragm (305, if present), and the air side diaphragm plate (14) on the bolt exactly as shown in FIG. 8.
- c. Apply medium-strength (blue) Loctite or equivalent to the bolt (304) threads. Screw the bolt into the shaft hand tight.
- d. Grease the shaft u-cups (106) and the length and ends of the diaphragm shaft (104). Slide the shaft into the housing.
- e. Repeat Steps a-c for the other diaphragm assembly.
- f. Hold one shaft bolt with a wrench and torque the other bolt to 20-25 ft-lb (27-34 N•m) at 100 rpm maximum. Do not over-torque.
- g. Reattach the first fluid cover (3). See **Torque Instructions**, page 18. Go to Step 7.

All Other Diaphragms - Plastic Pumps:

- a. Assemble the diaphragm (15), the backup diaphragm (305, if present), and the air side diaphragm plate (14) on the fluid side plate (13) exactly as shown in FIG. 8.
- b. Apply medium-strength (blue) Loctite or equivalent to the threads of the screw on the fluid side plate. Screw the assembly into the shaft hand-tight.
- c. Grease the shaft u-cups (106) and the length and ends of the diaphragm shaft (104). Slide the shaft into the housing.
- d. Repeat for the other diaphragm assembly
- e. Hold one of the plates with a wrench, and torque the other plate to 20-25 ft-lb (27-34 N•m) at 100 rpm maximum. Do not over-torque.
- f. Reattach the first fluid cover (3). See **Torque Instructions**, page 18.

7. To ensure proper seating and extend diaphragm life, attach the second fluid cover with air pressure on the pump.
 - a. See FIG. 9. Place the supplied tool (302) where the air valve gasket (108) normally goes. Arrows (A) must face toward the fluid cover that is already attached.

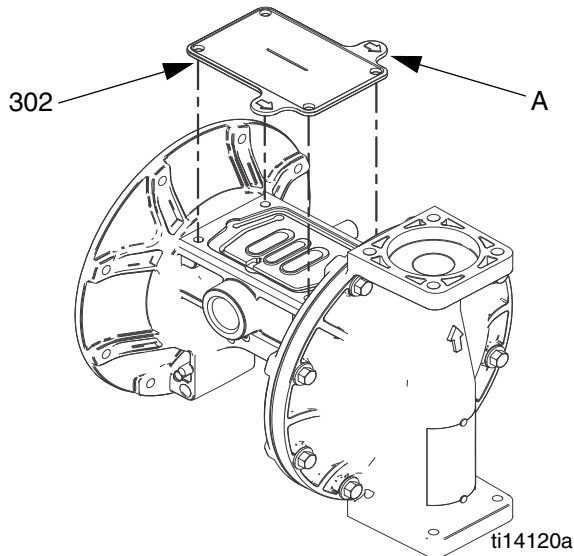

FIG. 9. Fluid cover tool

- b. Reattach the air valve.
- c. Supply a minimum of 20 psi (0.14 MPa, 1.4 bar) air pressure to the air valve. Shop air may be used. The diaphragm will shift so the second fluid cover will seat properly. Keep air pressure on until the second fluid cover is attached.
- d. Attach the second fluid cover (3). See **Torque Instructions**, page 18.
- e. Remove the air valve and the tool (302), replace the gasket (108), and reattach the air valve. See **Torque Instructions**, page 18.

NOTE: If you are replacing the diaphragms but not the air valve, you must remove the air valve and gasket, put the tool in place of the gasket, and put the air valve back on to get the air pressure needed for proper installation of the second fluid cover. Remember to remove the tool and replace the gasket when finished.

8. Reassemble the ball check valves and manifolds as explained on page 14.

Torque Instructions

NOTE: Fluid cover and manifold fasteners have a thread-locking adhesive patch applied to the threads. If this patch is worn, the screws may loosen during operation. Replace screws with new ones, or apply medium-strength (blue) Loctite or equivalent to the threads.

If fluid cover or manifold fasteners have been loosened, it is important to torque them using the following procedure to improve sealing.

NOTE: Always completely torque fluid covers before torquing manifolds.

Start all fluid cover screws a few turns. Then turn down each screw just until head contacts cover. Then turn each screw by 1/2 turn or less working in a crisscross pattern to specified torque. Repeat for manifolds.

Fluid cover and manifold fasteners:

100 in-lb (11.3 N•m)

Retorque the air valve fasteners (V) in a crisscross pattern to specified torque.

Air valve fasteners:

55 in-lb (6.2 N•m) for **plastic center sections**

80 in-lb (9.0 N•m) for **metal center sections**

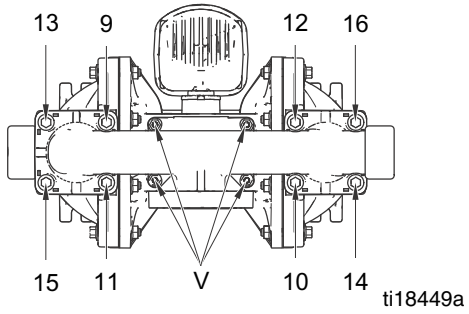
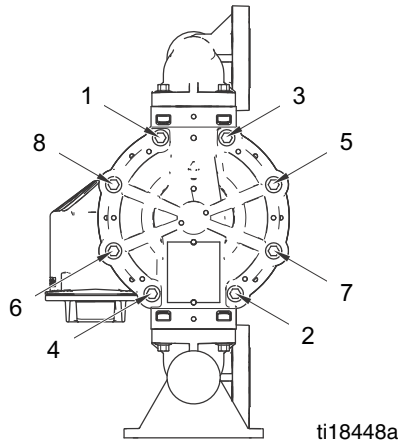
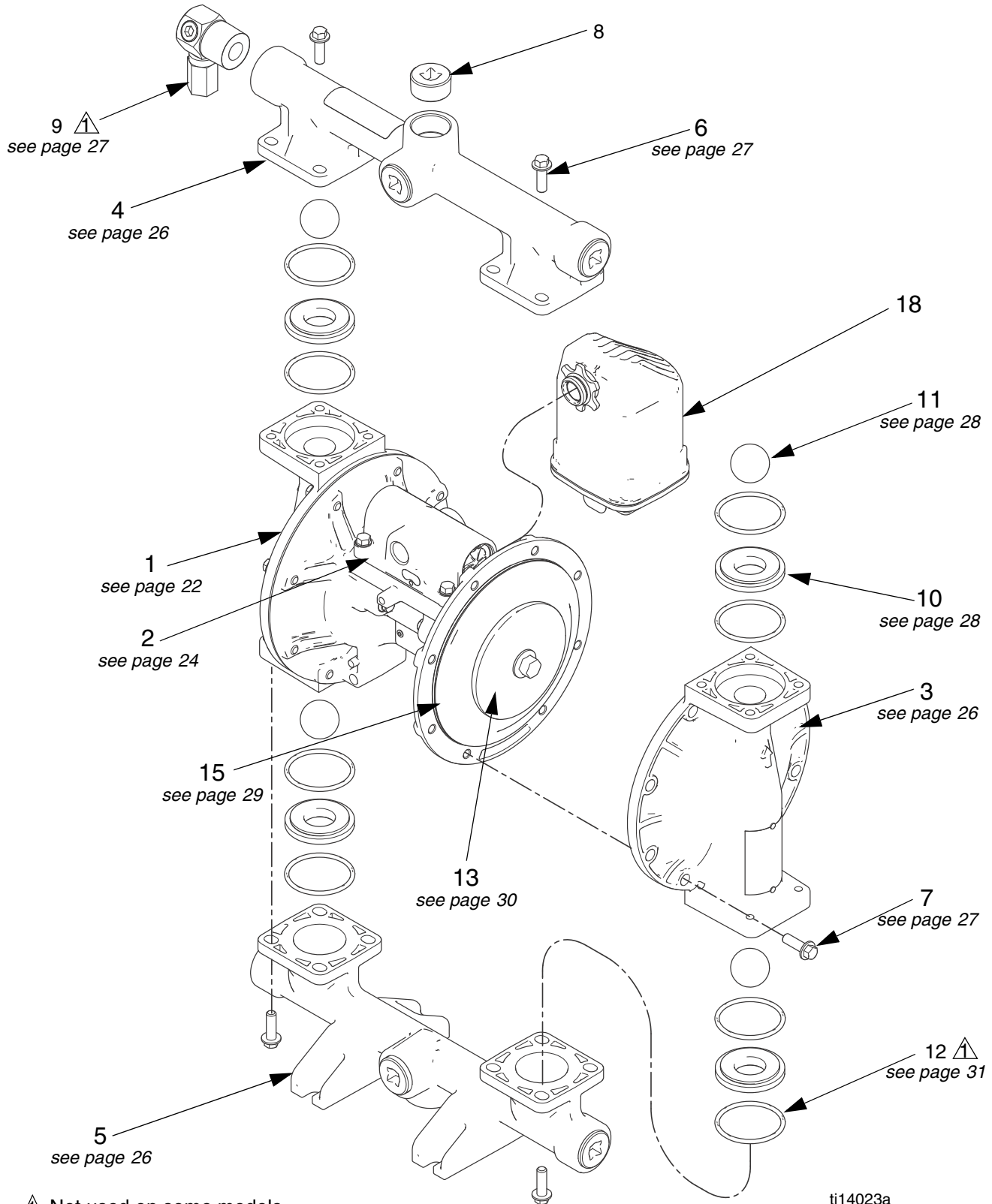

FIG. 10. Torque sequence

Parts



Not used on some models.

Parts/Kits Quick Reference

Use this table as a quick reference for parts/kits. See pages indicated in table for full description of kit contents.

Ref.	Part/Kit	Description	Qty.
1	Varies	Center Section; not sold separately, <i>see page 22</i> Aluminum Conductive Polypropylene Polypropylene	1
2	Varies	Air Valve; <i>see page 24</i>	1
3		Fluid Cover Kits; <i>see page 26</i>	2
	24B653	Aluminum	
	24C051	Conductive Polypropylene	
	24D347	Hastelloy	
	24C050	Polypropylene	
	24C052	PVDF	
	24C061	Hastelloy	
4		Outlet Manifold Kits; <i>see pages 26-27</i>	1
	24B649	Aluminum, npt	
	24B650	Aluminum, bspt	
	24C039	Conductive Poly, center flange	
	24C042	Conductive Poly, end flange	
	24D343	Hastelloy, npt	
	24D344	Hastelloy, bspt	
	24C038	Polypropylene, center flange	
	24C041	Polypropylene, end flange	
	24C040	PVDF, center flange	
	24C043	PVDF, end flange	
	24C057	Stainless Steel, npt	
	24C058	Stainless Steel, bspt	
5		Inlet Manifold Kits; <i>see page 26-27</i>	1
	24B651	Aluminum, npt	
	24B652	Aluminum, bspt	
	24C045	Conductive Poly, center flange	
	24C048	Conductive Poly, end flange	
	24D345	Hastelloy, npt	
	24D346	Hastelloy, bspt	
	24C044	Polypropylene, center flange	
	24C047	Polypropylene, end flange	
	24C046	PVDF, center flange	
	24C049	PVDF, end flange	
	24C059	Stainless Steel, npt	
	24C060	Stainless Steel, bspt	
6		Manifold Fasteners; 8-pack, <i>see page 27</i>	16
	24B654	Aluminum	
	24C056	Conductive Poly, Poly, and PVDF	
	24C064	Stainless Steel and Hastelloy	
7		Fluid Cover Fasteners; 8-pack, <i>see page 27</i>	16
	24B654	Aluminum	
	24C055	Conductive Poly, Poly, and PVDF	
	24C063	Stainless Steel or Hastelloy, aluminum center	
	24C056	Stainless Steel or Hastelloy, plastic center	
8	24C617	Plug; 6-pack, aluminum pumps only	6
9	24B910	Pressure Relief Valve; fuel dispense model only, <i>see page 27</i>	1

Ref.	Part/Kit	Description	Qty.
10		Seats; 4-pack, includes 8 o-rings where needed, <i>see page 28</i>	4
	24B630	Acetal	
	24B631	Aluminum	
	24B632	Buna-N	
	24B638	FKM Fluoroelastomer	
	24B633	Geolast	
	24B635	Polypropylene	
	24C721	PVDF	
	24B636	Santoprene	
	24B637	Stainless Steel	
	24B634	TPE	
11		Check Balls; 4-pack, includes 8 o-rings, <i>see page 28</i>	4
	24B639	Acetal	
	24B640	Buna-N	
	24B643	Polychloroprene	
	24B644	Polychloroprene with SST core	
	24B648	FKM Fluoroelastomer	
	24B641	Geolast	
	24B645	PTFE	
	24B646	Santoprene	
	24B647	Stainless Steel	
	24B642	TPE	
12	24B655	Manifold O-Ring (not used on some models); ptf, 8-pack, <i>see page 31</i>	8
13		Fluid Side Diaphragm Plate; included in Air and Fluid Plate Kits, <i>see page 30</i>	2
	24C035	Aluminum	
	24C036	Conductive Polypropylene	
	24D342	Hastelloy	
	24C036	Polypropylene	
	24C037	PVDF	
	24C062	Stainless Steel	
14	-----	Air Side Diaphragm Plate (not visible); included in Air and Fluid Plate Kits, <i>see Part 13 or page 30</i>	2
15		Diaphragm Kits; <i>see page 29</i>	2
	24B622	Buna-N Standard	
	24B629	FKM Fluoroelastomer Standard	
	24B623	Geolast Standard	
	24B628	Santoprene Standard	
	24B624	TPE Standard	
	24B625	Polychloroprene Overmolded	
	24B626	PTFE Overmolded	
	24B627	PTFE/EPDM Two-Piece	
	24F926	PTFE/Santoprene Two-Piece	
18	24D642	Muffler; 3/4 npt, polypropylene	1
19		Screw, ground, M5 x 0.8; not shown	1
	116343	Pumps with aluminum air valve	
	116344	Pumps with conductive poly air valve	
20▲	188621	Label, warning (not shown)	1

▲ Replacement Warning labels, signs, tags, and cards are available at no cost.

Center Section

Pump Size and Material	Center Section	Fluid Covers and Manifolds	Seats	Check Balls	Diaphragm	Manifold O-Rings
1050A	A01A	A2	AL	BN	TP	PT

Sample Configuration Number

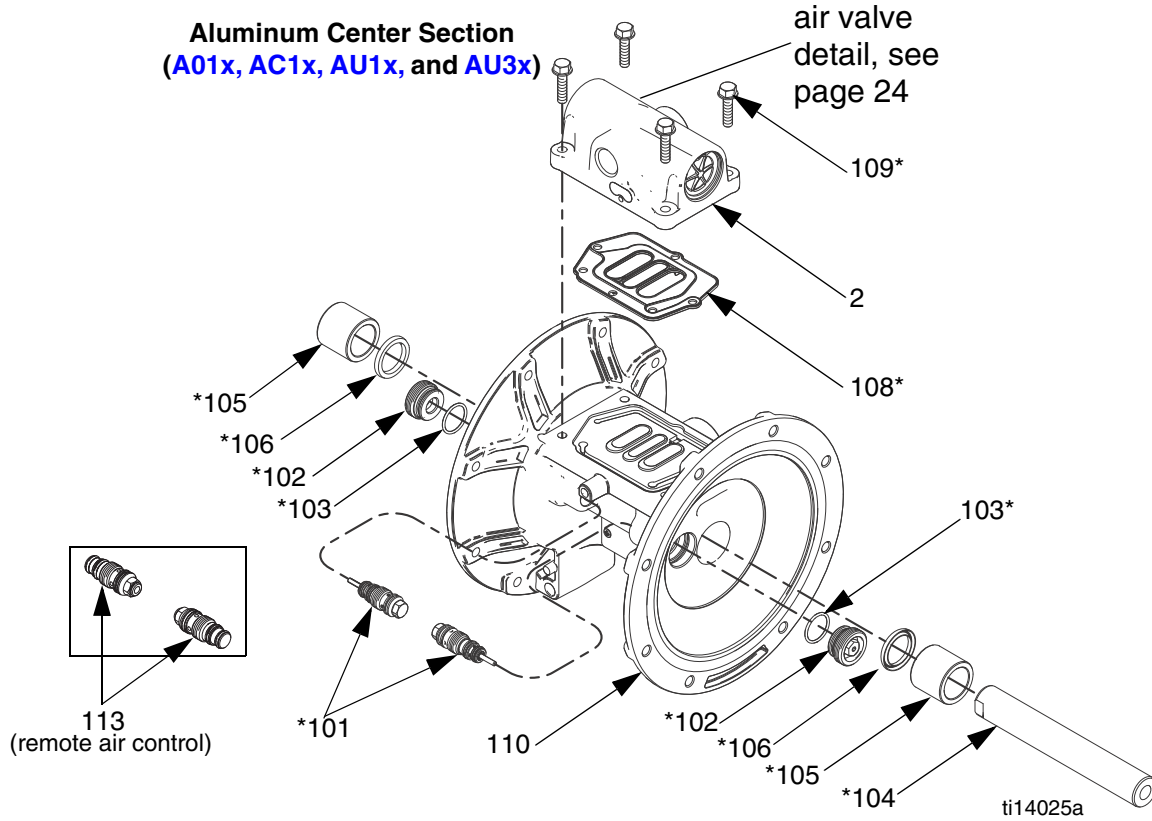

Ref.	Description	Qty.
101*	VALVE, pilot	2
102*	CARTRIDGES, pilot valve receiver	2
103*	O-RING, receiver cartridge	2
104*	SHAFT, center	1
105*	BEARING, center shaft	2
106*	U-CUP, center shaft	2
108*	GASKET, air valve	1
109*	SCREW, M6 x 25, stainless steel, (for aluminum center section models, Axxx)	4
110	HOUSING, center, not sold separately	1
112*	NUTS (for plastic center section models, C01x and P01x)	4
113	INSERT, remote pilot (for remote air control models, xxxD)	2

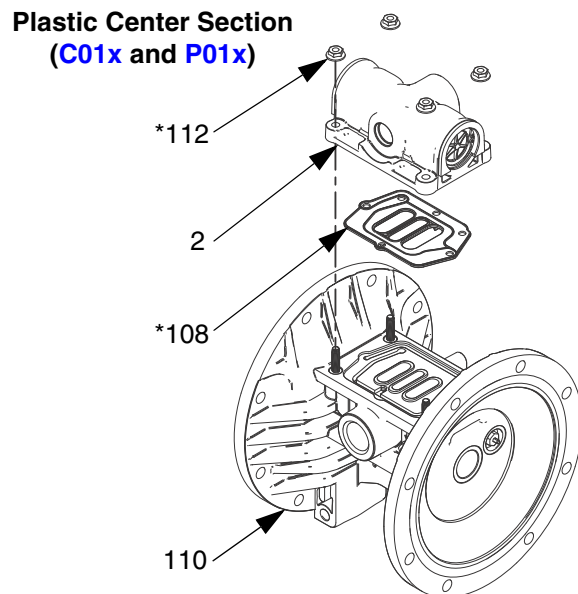

* Included in Center Section Rebuild Kit 24B621

ti14104a

Center Section Rebuild Kits (*)	
A01A-A01D, AU1A, AU3A, AC1A, C01A-C01D, P01A-P01D	24B621
A01E	24D730

Kits include:

- 2 pilot valves (101)
- 2 pilot cartridges (102)
- 2 cartridge o-rings, buna-N (103)
- 1 center shaft (104)
- 2 center shaft bearings (105)
- 2 center shaft u-cups (106)
- 1 air valve gasket (108)
- 4 bolts, M6 x 25, for **A01x** pumps (109)
- 4 nuts, for **P01x** and **C01x** pumps (112)
- 8 o-rings, PTFE (12)

Pilot Valve Assembly Kits	
A01A-A01D, AU1A, AU3A, AC1A, C01A-C01D, P01A-P01D	24B657
A01E	24C825

Kits include:

- 2 pilot valve assemblies (101)
- 2 pilot valve receiver cartridges (102)
- 2 receiver cartridge o-rings (103)

NOTE: **xxxD** models also require insert kit, shown below.

Kit 24D043, Remote Pilot Inserts xxxD (Remote Air Control)

Kit includes:

- 2 remote pilot inserts (113)

Center Shaft Kits	
A01A-A01D, AU1A, AU3A, AC1A, C01A-C01D, P01A-P01D	24B656
A01E	24D731

Kit includes:

- 1 center shaft (104)
- 2 center shaft bearings (105)
- 2 center shaft u-cups (106)

Center Shaft Bearing Kits	
A01A-A01D, AU1A, AU3A, AC1A, C01A-C01D, P01A-P01D	24B658
A01E	24D732

Kit includes:

- 2 center shaft bearings (105)
- 2 center shaft u-cups (106)

The center housing (110) is not sold separately.

Ground Screws (Ref. 19)

Ground Screw Kits	
A01A-A01E, AU1A, AU3A, and AC1A	116343
C01A-C01D	116344
P01A-P01D	None

Air Valve and Data Monitoring

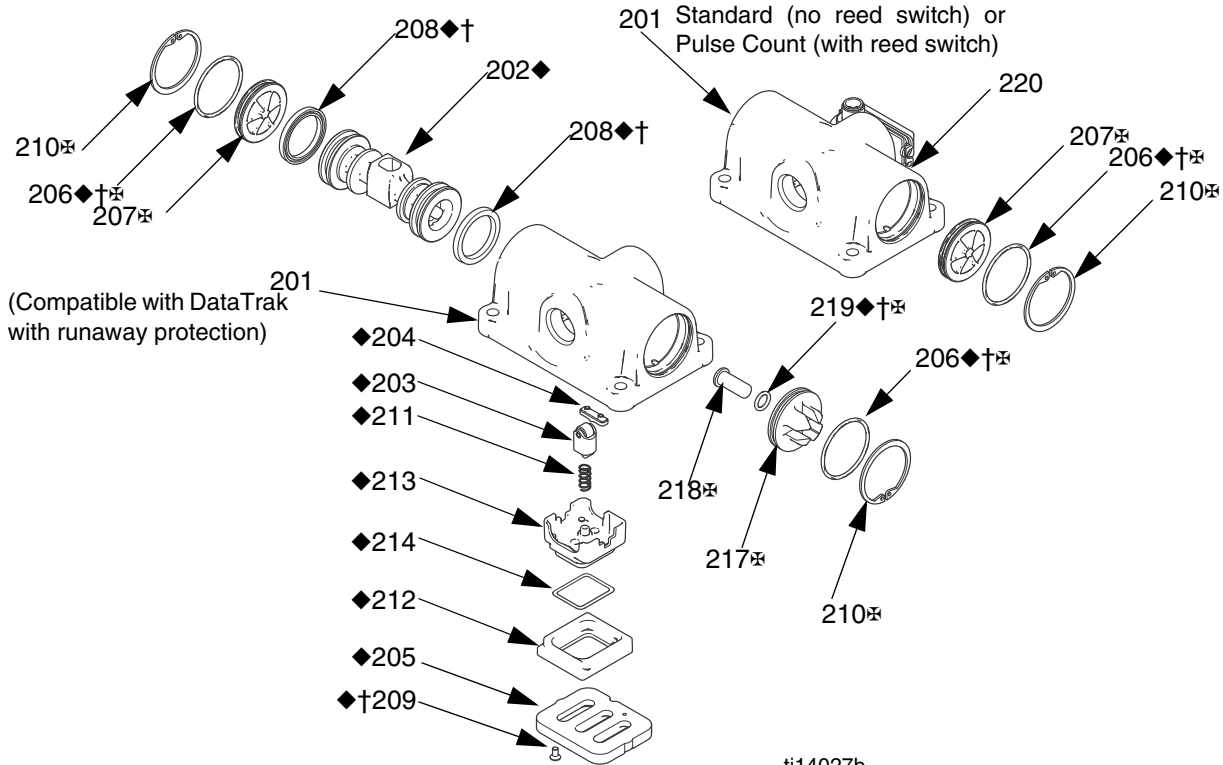

ti14027b

Ref.	Description	Qty.
201	HOUSING, not sold separately	1
202◆	PISTON	1
203◆	DETENT PISTON ASSEMBLY	1
204◆	CAM, detent	1
205◆	PLATE, air valve	1
206◆†‡	O-RING	2
207‡	CAP, end Standard (xxxA), Pulse Count (xxxB), or Remote (xxxD) DataTrak (xxxC)	2 1
208◆†	U-CUP	2
209◆†	SCREW	2
210◆‡	RETAINING RING	2
211◆	DETENT SPRING	1
212◆	BASE, cup	1
213◆	CUP	1
214◆	O-RING, cup	1
217‡	CAP, end (for DataTrak models with runaway protection, xxxC)	1
218‡	BUTTON, solenoid release (for DataTrak models with runaway protection, xxxC)	1

Ref.	Description	Qty.
219◆†‡	O-RING (for DataTrak models with runaway protection, xxxC)	1
220	REED SWITCH ASSEMBLY (for Pulse Count models, xxxB, includes fastener)	1

- ◆ Parts included in Air Valve Repair Kit. See page 25.
- † Parts included in Air Valve Seals Kit. See page 24.
- ‡ Parts included in Air Valve End Cap Kit. See page 25.

Air Valve Seal Kits (†)	
A01A-A01D, AU1A, AU3A, AC1A, C01A-C01D, P01A-P01D	24B769
A01E	24C983

Kit includes:

- 2 end cap o-rings (206)
- 2 piston u-cups (208)
- 2 screws, M3, shorter (209, for metal pumps)
- 2 screws, #4, longer (209, for plastic pumps)
- 1 solenoid release button o-ring (219)
- 1 air valve gasket (108)

Air Valve Repair Kits (◆)	
A01A-A01C, AU1A, AU3A, AC1A, C01A-C01C, P01A-P01C	24B768
A01D, C01D, P01D	24D044
A01E	24D699

Kits include:

- 1 air valve piston (202)
- 1 detent piston assembly (203)
- 1 detent cam (204)
- 1 air valve plate (205)
- 2 end cap o-rings (206)
- 2 piston u-cups (208)
- 2 screws, M3, shorter (209, for metal pumps)
- 2 screws, #4, longer (209, for plastic pumps)
- 1 detent spring (211)
- 1 air cup base (212)
- 1 air cup (213)
- 1 air cup o-ring (214)
- 1 solenoid release button o-ring (219)
- 1 air valve gasket (108)

Air Valve Replacement Kits	
AxxA	24B766
A01B	24B766
A01C	24B767
A01D	24D040
A01E	24C826
C01A	24B775
C01B	24B775
C01C	24B776
C01D	24D042
P01A	24B773
P01B	24B773
P01C	24B774
P01D	24D041

Kits include:

- 1 air valve assembly (2)
- 1 air valve gasket (108)
- 4 screws (109; models with aluminum centers)
- OR**
- 4 nuts (112; models with plastic centers)

Air Valve End Cap Kits (⊕)	
AxxA, A01B, or A01D	24A361
A01E	24D734
C01A, C01B, or C01D	24C053
P01A, P01B, or P01D	24C053
A01C	24A363
C01C	24C054
P01C	24C054

Standard or Pulse Count (no runaway protection solenoid) kits include:

- 2 end caps (207)
- 2 retaining rings (210)
- 2 o-rings (206)

DataTrak (runaway protection solenoid) Kits include:

- 1 standard end cap (207)
- 1 end cap with opening (217)
- 2 retaining rings (210)
- 2 o-rings (206)
- solenoid release button (218)
- o-ring for button (219)

Remote Air Control Conversion Kits	
Axxx	24D037
Cxxx	24D039
Pxxx	24D038

Kits include:

- 1 air valve assembly (2) with restrictor
- 1 air valve gasket (108)
- 4 screws (109; models with aluminum centers)
- OR**
- 4 nuts (112; models with plastic centers)
- 2 remote pilot inserts

Pulse Count Kits	
Axxx	24B798
Cxxx or Pxxx	24B796

Kit includes:

- reed switch module (220)
- mounting screw

Fluid Covers and Manifolds

Pump Size and Material	Air Valve and Center Section	Fluid Covers and Manifolds	Seats	Check Balls	Diaphragm	Manifold O-Rings
1050A	A01A	A1	AL	BN	TP	PT

Sample Configuration Number

Fluid Cover Kits	
A1, A2	24B653
C1, C2	24C051
H1, H2	24D347
P1, P2	24C050
F1, F2	24C052
S1, S2	24C061

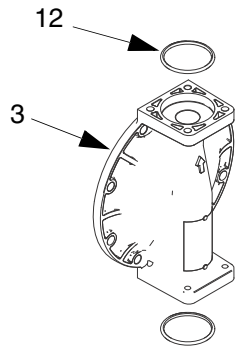

Kits include:

- 1 fluid cover (3)
- 4 o-rings, ptfe (12)

Hastelloy and Stainless Steel Outlet Manifold Kits	
H1	24D343
H2	24D344
S1	24C057
S2	24C058

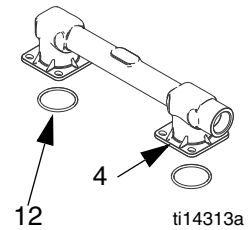

Kits include:

- 1 outlet manifold (4)
- 4 o-rings, ptfe (12)
- 1 warning label (20▲)

Aluminum Outlet Manifold Kits	
A1	24B649
A2	24B650

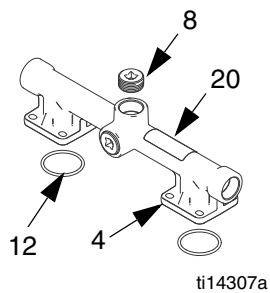

Kits include:

- 1 outlet manifold (4)
- 3 pipe plugs (8)
- 4 o-rings, ptfe (12)
- 1 warning label (20▲)

Hastelloy and Stainless Steel Inlet Manifold Kits	
H1	24D345
H2	24D346
S1	24C059
S2	24C060

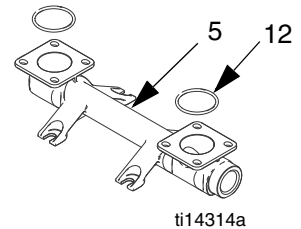

Kits include:

- 1 inlet manifold (5)
- 4 o-rings, ptfe (12)

Aluminum Inlet Manifold Kits	
A1	24B651
A2	24B652

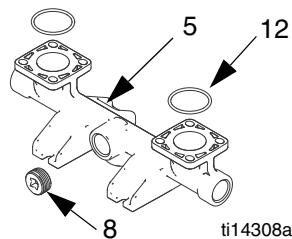

Kits include:

- 1 inlet manifold (5)
- 3 pipe plugs (8)
- 4 o-rings, ptfe (12)

Plastic Outlet Manifold Kits	
C1	24C039
C2	24C042
P1	24C038
P2	24C041
F1	24C040
F2	24C043

- Kits include:
- 1 outlet manifold (4)
 - 4 o-rings, ptfе (12)
 - 1 warning label (20▲)

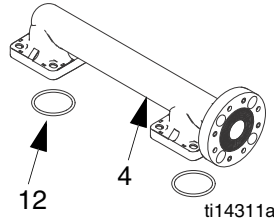
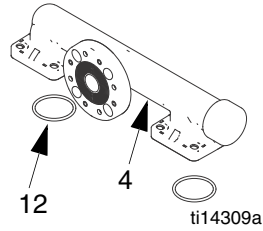

Plastic Inlet Manifold Kits	
C1	24C045
C2	24C048
P1	24C044
P2	24C047
F1	24C046
F2	24C049

- Kits include:
- 1 inlet manifold (5)
 - 4 o-rings, ptfе (12)

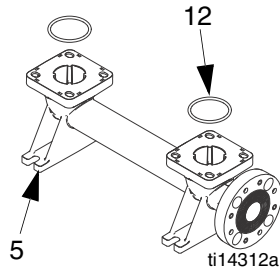
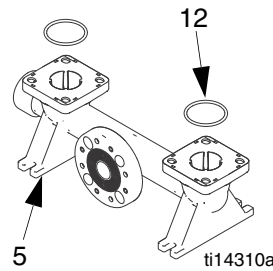

▲ Replacement Danger and Warning tags, labels, and cards are available at no cost.

Kit 24B910, Fluid Pressure Relief Valve Fuel Dispense Model only

- Kit includes:
- 1 valve, 3/8 nptf (9)

NOTE: See page 31 for manifold o-rings (12).

Manifold Fasteners (Ref. 9)

Manifold Fastener Kits	Fastener Description	Qty.
A1, A2	24B654 BOLT, hex head, steel, M8 x 25	8
C1, C2, P1, P2, F1, F2	24C056 BOLT, flange head, M8 x 32, stainless steel, includes nuts	8
S1, S2, H1, H2 with any center (Axxx, Cxxx, or Pxxx)	24C064 BOLT, hex head, M8 x 20, stainless steel, includes nuts	8

Fluid Cover Fasteners (Ref. 7)

Fluid Cover Fastener Kits	Description	Qty.
A1, A2	24B654 BOLT, hex head, steel, M8 x 25	8
C1, C2, P1, P2, F1, F2	24C055 BOLT, flange head, M8 x 45, stainless steel, includes nuts	8
S1, S2, H1, H2 aluminum center (Axxx)	24C063 BOLT, flange head, M8 x 25, stainless steel	8
S1, S2, H1, H2 plastic center (Cxxx or Pxxx)	24C056 BOLT, flange head, M8 x 32, stainless steel, includes nuts	8

Seats and Check Ball

Pump Size and Material	Air Valve and Center Section	Fluid Covers and Manifolds	Seats	Check Balls	Diaphragm	Manifold O-Rings
1050A	A01A	A2	AL	BN	TP	PT

Sample Configuration Number

Seat Kits	
AC	24B630
AL	24B631
BN (no o-rings)	24B632
FK (no o-rings)	24B638
GE	24B633
PP	24B635
PV	24C721
SP	24B636
SS	24B637
TP (no o-rings)	24B634

Kits include:

- 4 seats, material indicated in table (10)
- 8 o-rings, PTFE, included unless table says “no o-rings” (12)

NOTE: Some kits may not be available for your model. See the selector tool at www.graco.com or speak with your distributor.

Check Ball Kits	
AC	24B639
BN	24B640
CR	24B643
CW	24B644
FK	24B648
GE	24B641
PT	24B645
SP	24B646
SS	24B647
TP	24B642

Kits Include:

- 4 balls, material indicated in table (11)
- 8 o-rings, PTFE (12)

NOTE: Some kits may not be available for your model. See the selector tool at www.graco.com or speak with your distributor.

Diaphragms

Pump Size and Material	Air Valve and Center Section	Fluid Covers and Manifolds	Seats	Check Balls	Diaphragm	Manifold O-Rings
1050A	A01A	A2	AL	BN	TP	PT

Sample Configuration Number

NOTE: Some kits may not be available for your model. See the selector tool at www.graco.com or speak with your distributor.

Standard Diaphragm Kits	
BN	24B622
FK	24B629
GE	24B623
SP	24B628
TP	24B624

Kits include:

- 8 o-rings, ptfе (12)
- 2 diaphragms (15, material indicated in table)
- 2 o-rings for the bolt (301, used only on metal pumps)
- 1 diaphragm install tool (302)

NOTE: Fluid plates (13, 14) and diaphragm shaft bolts (304) are sold separately. See page 30. The shaft (104) is part of Kit 24B621, the Center Section Rebuild Kit.

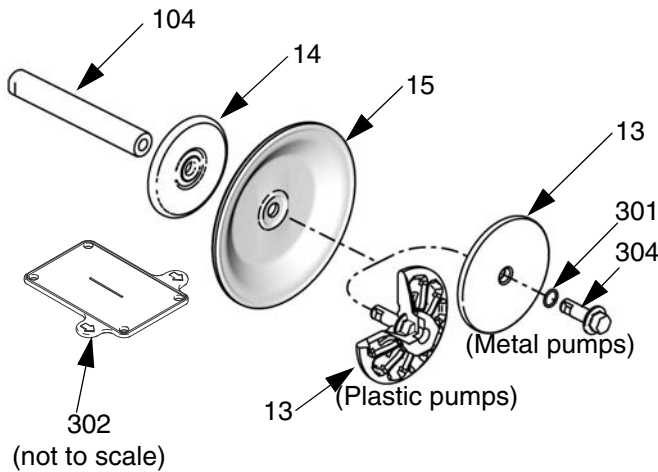

Overmolded Diaphragm Kits	
CO	24B625
PO	24B626

Kits include:

- 8 o-rings, ptfе (12)
- 2 overmolded diaphragms (15, material indicated in table)
- 2 diaphragm set screws, stainless steel (303)
- 1 diaphragm install tool (302)

NOTE: Fluid plates (14) are sold separately. See page 30. The shaft (104) is part of Kit 24B621, the Center Section Rebuild Kit.

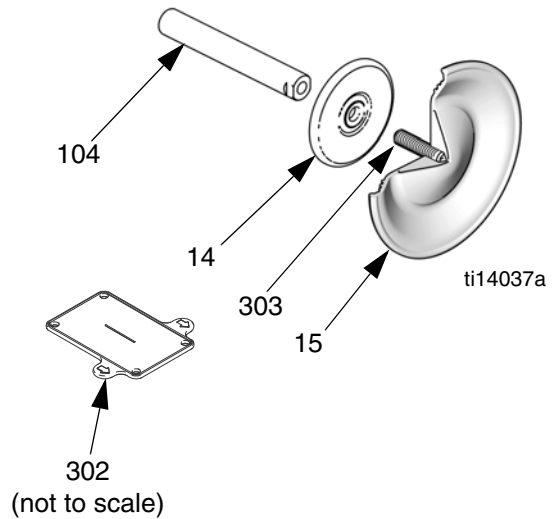

Diaphragms (continued)

Pump Size and Material	Air Valve and Center Section	Fluid Covers and Manifolds	Seats	Check Balls	Diaphragms	Manifold O-Rings
1050A	A01A	A2	AL	BN	TP	PT

Sample Configuration Number

Two-Piece Diaphragm Kits	
PT	24B627
n/a	24F926

Kits include:

- 8 o-rings, PTFE (12)
- 2 diaphragms, PTFE (15)
- 2 backup diaphragms (305, material indicated in table)
- 2 o-rings for the bolt (301, used only on metal pumps)
- 1 diaphragm install tool (302)

NOTE: Fluid plates (13, 14) and diaphragm shaft bolts (304) are sold separately. See page 30. The shaft (104) is part of Kit 24B621, the Center Section Rebuild Kit.

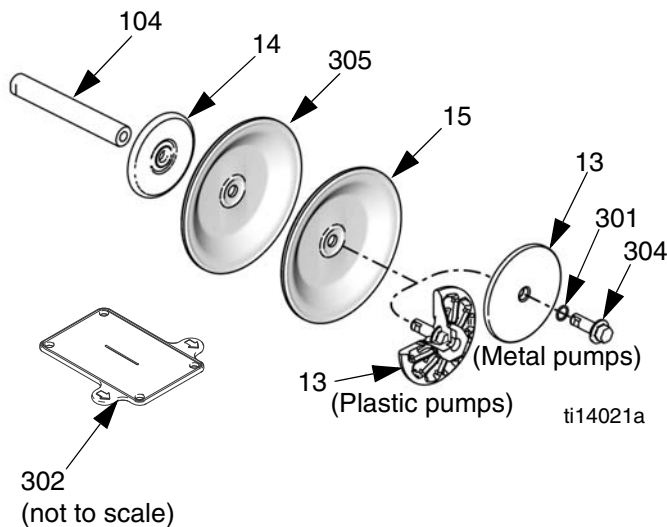

Air and Fluid Plate Kits	
1050A	24C035
1050C	24C036
1050H	24D342
1050P	24C036
1050F	24C037
1050S	24C062

Kits for **aluminum, hastelloy, and stainless steel** pumps include:

- air side diaphragm plate (14)
- fluid side diaphragm plate (13)
- o-ring (301)
- bolt (304)

Kits for **polypropylene, conductive polypropylene, and PVDF** pumps include:

- air side diaphragm plate (14)
- fluid side diaphragm plate (13, includes bolt)

Diaphragm Shaft Bolt (Metal Pumps)

Kit 24C099 includes:

- 1 bolt, stainless steel, M12 x 35 (304)
- 1 o-ring (301)

Manifold O-Rings

Pump Size and Material	Air Valve and Center Section	Fluid Covers and Manifolds	Seats	Check Balls	Diaphragm	Manifold O-Rings
1050A	A01A	A2	AL	BN	TP	PT

Sample Configuration Number

O-Ring Kit	Qty.
PT	8
--	0

Kit Includes:

- 8 o-rings, PTFE (12)

DataTrak

NOTE: See DataTrak manual, 313840, for all DataTrak related part numbers and kit information, including the reed switch and solenoid.

Accessories

Fluid Pressure Relief Kit 238428 (for aluminum pumps)

Includes pipe bushings, hose adapter, relief valve, and tubing.

Fluid Pressure Relief Kit 112119 (for plastic pumps)

Includes fluid pressure relief valve.

Wall Mount Kit 24C637

Includes bracket, 4 dampeners, 8 washers, and 8 lock nuts.

Wall Bracket Dampener Kit 24E769

Includes 4 dampeners.

Rubber Foot Mounting Kit 236452

Includes washers, nuts, and rubber feet.

Grounding Wire Assembly Kit 238909

Includes ground wire and clamp.

Air Controls Kit 246946

Includes 1/4 npt air filter/regulator with 40 micron element and air pressure gauge.

Air Controls Kit 246947

Includes 1/2 npt air filter/regulator with 40 micron element and air pressure gauge.

Standard Pipe Flange Kits

239005 - Polypropylene

239008 - Stainless steel

239009 - PVDF

Each kit includes the pipe flange, a PTFE gasket, bolts, spring lock washers, flat washers and nuts.

Optional Muffler

Part No. 102656, 3/4 npt, aluminum.

Technical Data

Maximum fluid working pressure	125 psi (0.86 MPa, 8.6 bar)
Air pressure operating range	20-125 psi (0.14-0.86 MPa, 1.4-8.6 bar)
Fluid displacement per cycle	0.17 gal. (0.64 liters)
Air consumption at 70 psi (0.48 MPa, 4.8 bar), 20 gpm (76 lpm)	25 scfm
Maximum values with water as media under submerged inlet conditions at ambient temperature:	
Maximum air consumption	67 scfm
Maximum free-flow delivery	50 gpm (189 lpm)
Maximum pump speed.	280 cpm
Maximum suction lift (varies widely based on ball/seat selection and wear, operating speed, material properties, and other variables)	16 ft (4.9 m) dry, 29 ft (8.8 m) wet
Maximum size pumpable solids	1/8 in. (3.2 mm)
Recommended cycle rate for continuous use	93 - 140 cpm
Recommended cycle rate for circulation systems	20 cpm
Sound Power*	
at 70 psi (0.48 MPa, 4.8 bar) and 50 cpm	78 dBa
at 100 psi (0.7 MPa, 7.0 bar) and full flow	90 dBa
Sound Pressure**	
at 70 psi (0.48 MPa, 4.8 bar) and 50 cpm	84 dBa
at 100 psi (0.7 MPa, 7.0 bar) and full flow	96 dBa
Fluid temperature range.	see page 33
Air inlet size	1/2 npt(f)
Fluid inlet size	
Aluminum (1050A), Hastelloy (1050H) or Stainless Steel (1050S)	1 in. npt(f) or 1 in. bspt
Conductive Poly (1050C), Polypropylene (1050P), or PVDF (1050F)	1 in. raised face ANSI/DIN flange
Fluid outlet size	
Aluminum (1050A), Hastelloy (1050H) or Stainless Steel (1050S)	1 in. npt(f) or 1 in. bspt
Conductive Poly (1050C), Polypropylene (1050P), or PVDF (1050F)	1 in. raised face ANSI/DIN flange
Weight	
Aluminum (1050A)	23 lb. (10.5 kg)
Conductive Polypropylene (1050C) and Polypropylene (1050P)	18 lb. (8.2 kg)
Hastelloy	41 lb. (18.6 kg)
PVDF (1050F)	26 lb (11.8 kg)
Stainless Steel (1050S)	
with conductive polypropylene center	36.3 lb. (16.5 kg)
with polypropylene center	37.3 lb. (16.9 kg)
with aluminum center.	41.4 lb. (18.8 kg)
Wetted parts include material(s) chosen for seat, ball, and diaphragm options, plus the pump's material of construction	
1050A.	Aluminum
1050H	Hastelloy
1050C and 1050P	Polypropylene
1050F.	PVDF
1050S.	Stainless Steel

Non-wetted external parts	
Aluminum (1050A)	aluminum, coated carbon steel
Hastelloy (1050H).	hastelloy, stainless steel, polypropylene or aluminum (if used in center section)
Plastic (1050P, 1050C, and 1050F)	stainless steel, polypropylene
Stainless Steel (1050S)	stainless steel, polypropylene or aluminum (if used in center section)

Reference Information

Maximum Storage Time (varies with conditions)	2 years
Maximum Lifetime (varies with operating conditions and maintenance)	10 years
Power Efficiency Factor (varies based on pump configuration, operating parameters, and material)	1.61 gal. air consumed/1 gal. fluid pumped at 70 psi (1.61 liter air consumed/1 liter fluid pumped at 4.8 bar)

* Sound power measured per ISO-9614-2.

** Sound pressure was tested 3.28 ft (1 m) from equipment.

All trademarks mentioned in this manual are the property of their respective owners.

Fluid Temperature Range

NOTICE

Temperature limits are based on mechanical stress only. Certain chemicals will further limit the fluid operating temperature range. Stay within the temperature range of the most-restricted wetted component. Operating at a fluid temperature that is too high or too low for the components of your pump may cause equipment damage.

Diaphragm/Ball/Seat Material	Fluid Temperature Range					
	Aluminum, Hastelloy, or Stainless Steel Pumps		Polypropylene or Conductive Polypropylene Pumps		PVDF Pumps	
	Fahrenheit	Celsius	Fahrenheit	Celsius	Fahrenheit	Celsius
Acetal (AC)	10° to 180°F	-12° to 82°C	32° to 150°F	0° to 66°C	10° to 180°F	-12° to 82°C
Buna-N (BN)	10° to 180°F	-12° to 82°C	32° to 150°F	0° to 66°C	10° to 180°F	-12° to 82°C
FKM Fluoroelastomer (FK)*	-40° to 275°F	-40° to 135°C	32° to 150°F	0° to 66°C	10° to 225°F	-12° to 107°C
Geolast® (GE)	-40° to 150°F	-40° to 66°C	32° to 150°F	0° to 66°C	10° to 150°F	-12° to 66°C
Polychloroprene overmolded diaphragm (CO) or Polychloroprene check balls (CR or CW)	0° to 180°F	-18° to 82°C	32° to 150°F	0° to 66°C	10° to 180°F	-12° to 82°C
Polypropylene (PP)	32° to 150°F	0° to 66°C	32° to 150°F	0° to 66°C	32° to 150°F	0° to 66°C
PTFE overmolded diaphragm (PO)	40° to 180°F	4.0° to 82°C	40° to 150°F	4° to 66°C	40° to 180°F	4.0° to 82°C
PTFE check balls or two-piece PTFE/EPDM diaphragm (PT)	40° to 220°F	4° to 104°C	40° to 150°F	4° to 66°C	40° to 220°F	4° to 104°C
PVDF (PV)	10° to 225°F	-12° to 107°C	32° to 150°F	0° to 66°C	10° to 225°F	-12° to 107°C
Santoprene® (SP)	-40° to 180°F	-40° to 82°C	32° to 150°F	0° to 66°C	10° to 180°F	-12° to 82°C
TPE (TP)	-20° to 150°F	-29° to 66°C	32° to 150°F	0° to 66°C	10° to 150°F	-12° to 66°C

* The maximum temperature listed is based on the ATEX standard for T4 temperature classification. If you are operating in a non-explosive environment, FKM fluoroelastomer's maximum fluid temperature in aluminum or stainless steel pumps is 320°F (160°C).

Graco Standard Husky Pump Warranty

Graco warrants all equipment referenced in this document which is manufactured by Graco and bearing its name to be free from defects in material and workmanship on the date of sale to the original purchaser for use. With the exception of any special, extended, or limited warranty published by Graco, Graco will, for a period of five years from the date of sale, repair or replace any part of the equipment determined by Graco to be defective. This warranty applies only when the equipment is installed, operated and maintained in accordance with Graco's written recommendations.

This warranty does not cover, and Graco shall not be liable for general wear and tear, or any malfunction, damage or wear caused by faulty installation, misapplication, abrasion, corrosion, inadequate or improper maintenance, negligence, accident, tampering, or substitution of non-Graco component parts. Nor shall Graco be liable for malfunction, damage or wear caused by the incompatibility of Graco equipment with structures, accessories, equipment or materials not supplied by Graco, or the improper design, manufacture, installation, operation or maintenance of structures, accessories, equipment or materials not supplied by Graco.

This warranty is conditioned upon the prepaid return of the equipment claimed to be defective to an authorized Graco distributor for verification of the claimed defect. If the claimed defect is verified, Graco will repair or replace free of charge any defective parts. The equipment will be returned to the original purchaser transportation prepaid. If inspection of the equipment does not disclose any defect in material or workmanship, repairs will be made at a reasonable charge, which charges may include the costs of parts, labor, and transportation.

THIS WARRANTY IS EXCLUSIVE, AND IS IN LIEU OF ANY OTHER WARRANTIES, EXPRESS OR IMPLIED, INCLUDING BUT NOT LIMITED TO WARRANTY OF MERCHANTABILITY OR WARRANTY OF FITNESS FOR A PARTICULAR PURPOSE.

Graco's sole obligation and buyer's sole remedy for any breach of warranty shall be as set forth above. The buyer agrees that no other remedy (including, but not limited to, incidental or consequential damages for lost profits, lost sales, injury to person or property, or any other incidental or consequential loss) shall be available. Any action for breach of warranty must be brought within six (6) years of the date of sale.

GRACO MAKES NO WARRANTY, AND DISCLAIMS ALL IMPLIED WARRANTIES OF MERCHANTABILITY AND FITNESS FOR A PARTICULAR PURPOSE, IN CONNECTION WITH ACCESSORIES, EQUIPMENT, MATERIALS OR COMPONENTS SOLD BUT NOT MANUFACTURED BY GRACO. These items sold, but not manufactured by Graco (such as electric motors, switches, hose, etc.), are subject to the warranty, if any, of their manufacturer. Graco will provide purchaser with reasonable assistance in making any claim for breach of these warranties.

In no event will Graco be liable for indirect, incidental, special or consequential damages resulting from Graco supplying equipment hereunder, or the furnishing, performance, or use of any products or other goods sold hereto, whether due to a breach of contract, breach of warranty, the negligence of Graco, or otherwise.

FOR GRACO CANADA CUSTOMERS

The Parties acknowledge that they have required that the present document, as well as all documents, notices and legal proceedings entered into, given or instituted pursuant hereto or relating directly or indirectly hereto, be drawn up in English. Les parties reconnaissent avoir convenu que la rédaction du présente document sera en Anglais, ainsi que tous documents, avis et procédures judiciaires exécutés, donnés ou intentés, à la suite de ou en rapport, directement ou indirectement, avec les procédures concernées.

Graco Information

For the latest information about Graco products, visit www.graco.com.

For patent information, see www.graco.com/patents.

TO PLACE AN ORDER, contact your Graco distributor or call to identify the nearest distributor.

Phone: 612-623-6921 **or Toll Free:** 1-800-328-0211 **Fax:** 612-378-3505

All written and visual data contained in this document reflects the latest product information available at the time of publication. Graco reserves the right to make changes at any time without notice.

Original instructions. This manual contains English. MM 313435

Graco Headquarters: Minneapolis

International Offices: Belgium, China, Japan, Korea

GRACO INC. AND SUBSIDIARIES • P.O. BOX 1441 • MINNEAPOLIS MN 55440-1441 • USA

Copyright 2009, Graco Inc. All Graco manufacturing locations are registered to ISO 9001.

www.graco.com

Revision S - July 2014