

Parts Manual

with Wiring Diagrams

for domestic and standard export ovens

Serial # Code (Nine Digit Code)
(for units produced prior to mid-July, 2006)
First 4 digits - order of production
Fifth digit - model specific
Sixth and Seventh digit - month of production
Eighth and Ninth digit - year of production

Serial # Code (Ten Digit Code)
(for units produced after mid-July, 2006)
First 5 digits - order of production
Sixth digit - model specific
Seventh and Eighth digit - month of production
Ninth and Tenth digit - year of production

The PS570G replaced the PS570S.
They are different!
The PS570G requires a 208/240V, 1Phase Power Supply.
Therefore the Control Circuit is 208/240V.
A Modulating Gas Valve and Signal Amplifier Board were
incorporated to reduce energy consumption and increase
cooking efficiency.
We call this our Energy Management System (EMS).

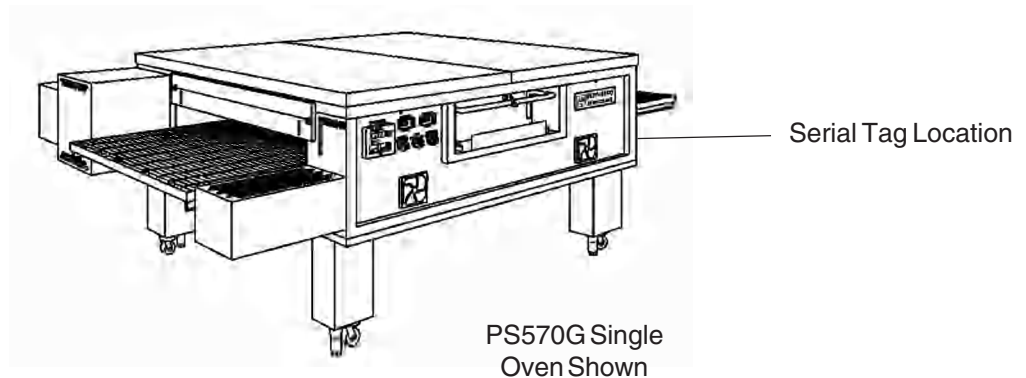

Table of Contents: Page 2

www.middleby.com

email: techsupport@middleby.com

1-847-741-3300 fax 1-847-741-4406

Table of Contents

Specification Sheet	3
Key Parts	7
View of Installation and Base Pad Kit(s)	8
Parts for Installation and Base Kit(s)	9
View of Oven Panels, End Plugs, Window and Legs	10
Parts for Oven Panels, End Plugs, Window and Legs	11
View of Front Control Area	12
Parts for Front Control Area	13
View of Gas Piping and Burner Assembly	14
Parts for Gas Piping and Burner Assembly	15
View of Rear Blower/Motor Assembly	16
Parts for Rear Blower/Motor Assembly	17
View of Rear Capacitor Area	18
Parts for Rear Capacitor Area	19
View of “Single” Belt Conveyor	20
Parts for “Single” Belt Conveyor	21
View of “50-50” Split Belt Conveyor	22
Parts for “50-50” Split Belt Conveyor	23
Standard Finger Configuration 31257 and Part Numbers	24
Wiring Diagram, G208-240 volt 50/60 Hz, 1 Phase, US, 45520 Rev E 2 of 2	25
Ladder Diagram, G208-240 volt 50/60 Hz, 1 Phase, US, 45520 Rev E 1 of 2	26
Wiring Diagram, G208-240 volt 50/60 Hz, 1 Phase, AU, 46978 Rev D	27
Wiring Diagram, G208-240 volt 50/60 Hz, 1 Phase, CAN, 47285 Rev C	28
Wiring Diagram, G230 volt 50 Hz, 1 Phase, CE, DN 47263 Rev C	29
Wiring Diagram, G230 volt 50 Hz, 1 Phase, CE, DUT 47265 Rev C	30
Wiring Diagram, G230 volt 50 Hz, 1 Phase, CE, FR 47257 Rev C	31
Wiring Diagram, G230 volt 50 Hz, 1 Phase, CE, GM 47255 Rev C	32
Wiring Diagram, G230 volt 50 Hz, 1 Phase, CE, GK 47261 Rev C	33
Wiring Diagram, G230 volt 50 Hz, 1 Phase, CE, IT 47253 Rev C	34
Wiring Diagram, G230 volt 50 Hz, 1 Phase, CE, SP 47259 Rev C	35
Wiring Diagram, G230 volt 50 Hz, 1 Phase, CE, UK 45587 Rev F 2 of 2	36
Ladder Diagram, G230 volt 50 Hz, 1 Phase, CE, UK 45587 Rev F 1 of 2	37



Principle

Middleby Marshall PS Series Conveyor ovens bake both faster and at a lower temperature than other ovens. Patented vertical columns of hot air move heat aerodynamically instead of using high temperatures. The streams of hot air remove the boundary layers of cool heavy air which tend to insulate the product. This gives very rapid baking without burning. All Middleby ovens are designed to cook a multitude of products including pizza, seafood, bagels, ethnic foods and more.

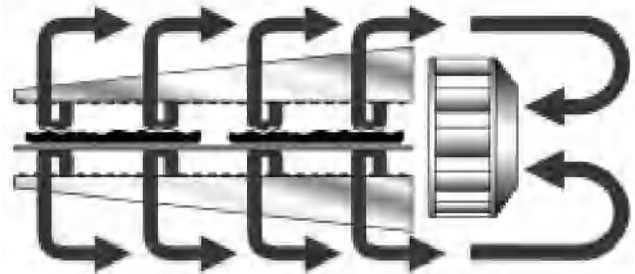

Standard Features

- **Impingement PLUS!** low oven profile and dual air return
- **Patented EMS Energy Management System** reduces gas consumption and increases cooking efficiency
- 70"/1778mm-long cooking chamber
- 32"/813mm-wide, 106"/2692mm-long conveyor belt
- Stackable up to four units high
- Patented "Jet Sweep" impingement process that delivers constant heat to the chamber
- Microprocessor-controlled bake time/conveyor speed
- Customer-specific adjustable jet fingers that allow control of heat delivery
- Stainless steel front, sides and top
- Front-loading window with cool handle
- Reversible conveyor direction

Optional Features

- Split belt - two 15"/381mm belts with individually-adjustable speed settings

Conserves Energy

Middleby ovens provide very efficient heat transfer to product. Energy is conserved as air is recycled from heater to product, with minimum flue or vent loss.

Cleanability

PS570 ovens are designed for easy cleaning. Removable parts include: crumb pans, end panels, air fingers, and a folding conveyor belt assembly.

Easily Serviced

Control compartment is designed for quick and easy access. All electrical controls are door-mounted.

Warranty

All PS570 models have a one year parts and labor warranty. Oven start-up and demonstration are included at no additional charge (USA only).

Ventilation

For installation under a ventilation hood only.



A MIDDLEBY COMPANY
1400 Toastmaster Drive
Elgin, Illinois 60120 USA
(847) 741-3300 Fax: (847) 741-0015
www.middleby.com

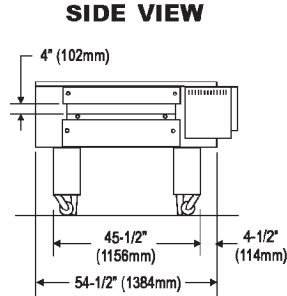
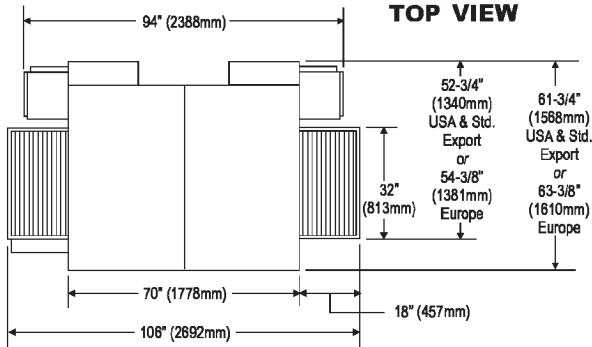

- ① Gas Utility Connection
- ② Electrical Utility Connection

**PS570-1 Single Oven
with 19" (483mm) leg extensions**

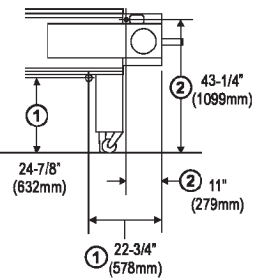
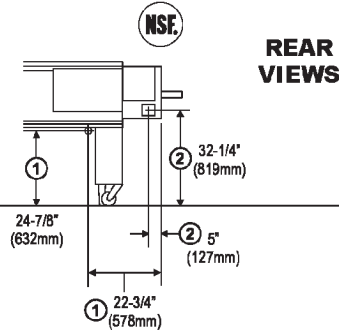
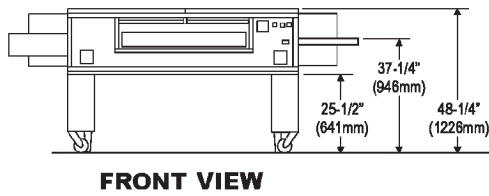

**PS570-2 Double Oven
with 10" (254mm) leg extensions**

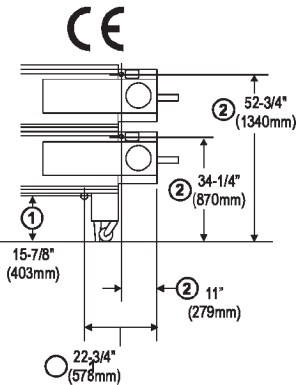
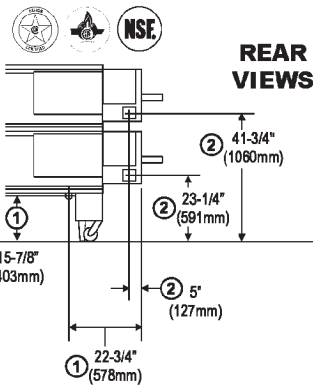
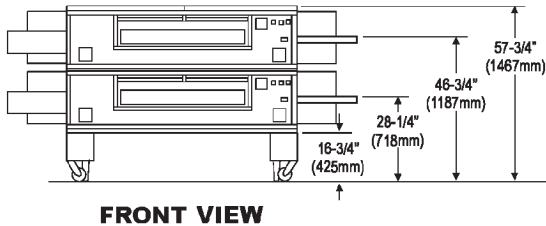

**PS570-2 Double Oven
with 15" (381mm) leg extensions**

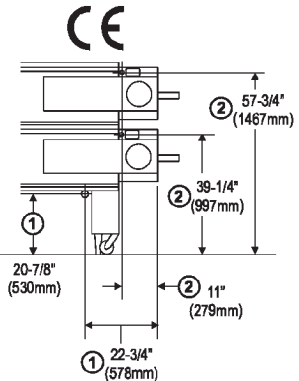
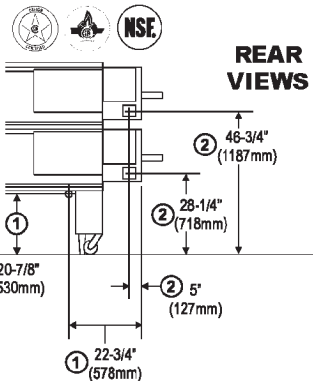
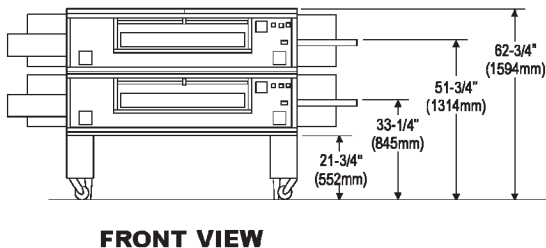

**PS570-3 Triple Oven
with 4" (102mm) leg extensions**

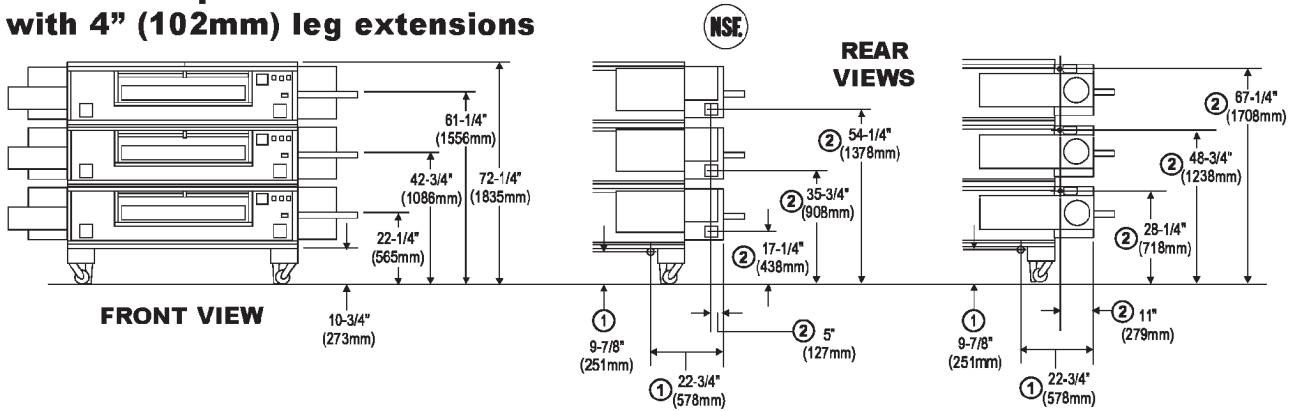

**PS570-3 Triple Oven
without leg extensions**

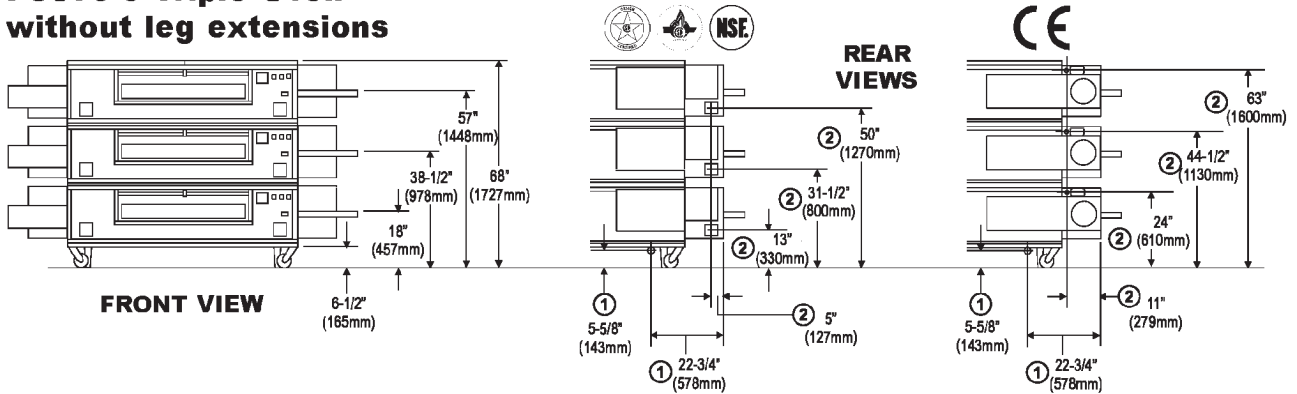

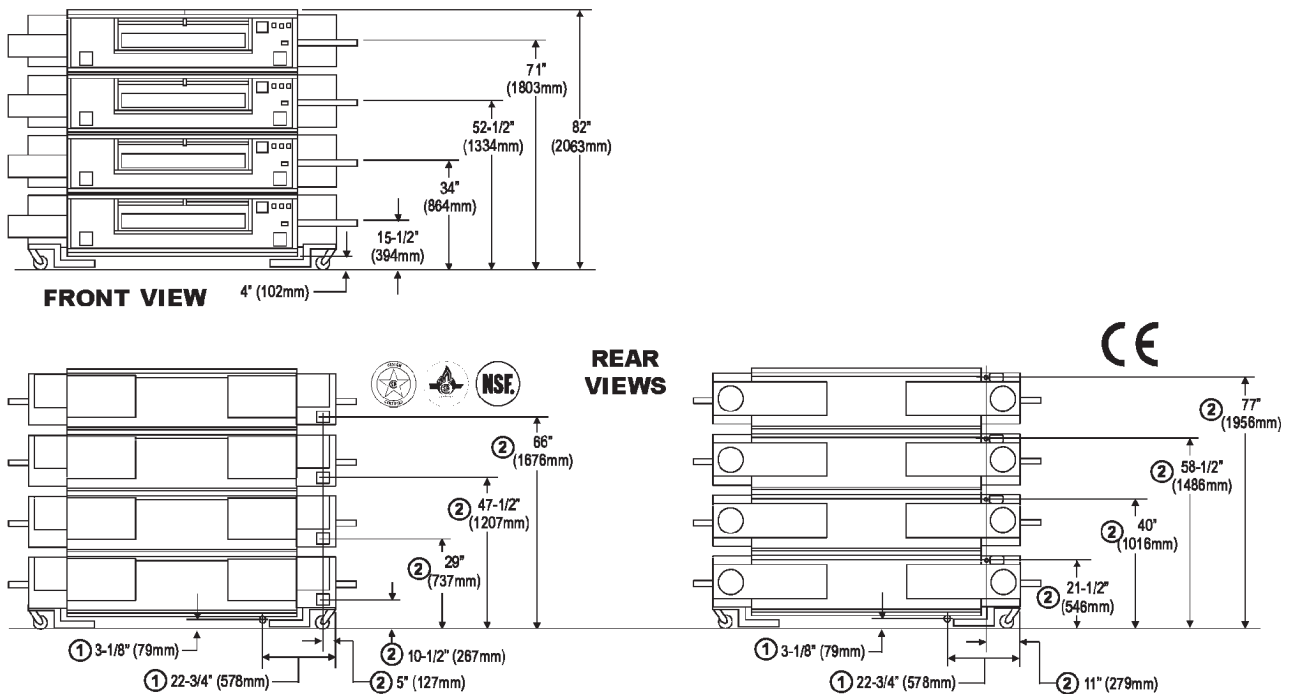

**PS570-4 Quad Oven
with outriggers**





RECOMMENDED MINIMUM CLEARANCES

Rear of oven to wall	Control end of oven to wall	Non-control end of oven to wall
0" (0mm)	0" (0mm)	0" (0mm)

GENERAL INFORMATION

Model	Heating Zone	Baking Area	Belt Length	Belt Width	Depth   	Depth CE	Height	Max. Operating Temp.	Bake Time Range	Ship Wt.	Ship Cube
PS570-1 with 19" (483mm) leg extensions	70" 1778mm	15.5 sq. ft. 1.44m ²	106" 2692mm	32" 813mm	61-3/4" 1568mm	63-3/8" 1610mm	48-1/4" 1226mm	550°F 288°C	4- 29:50	1750 lbs. 795kg	160 ft. ³ 4.5m ³
PS570-2 with 10" (254mm) leg extensions	140" 3556mm	31 sq. ft. 2.88m ²	106" 2692mm	32" 813mm	61-3/4" 1568mm	63-3/8" 1610mm	57-3/4" 1467mm	550°F 288°C	4- 29:50	3500 lbs. 1589kg	320 ft. ³ 9.0m ³
PS570-2 with 15" (381mm) leg extensions	140" 3556mm	31 sq. ft. 2.88m ²	106" 2692mm	32" 813mm	61-3/4" 1568mm	63-3/8" 1610mm	62-3/4" 1594mm	550°F 288°C	4- 29:50	3500 lbs. 1589kg	320 ft. ³ 9.0m ³
PS570-3 with 4" (102mm) leg extensions	210" 5334mm	46.5 sq. ft. 4.32m ²	106" 2692mm	32" 813mm	61-3/4" 1568mm	63-3/8" 1610mm	72-1/4" 1835mm	550°F 288°C	4- 29:50	5250 lbs. 2384kg	480 ft. ³ 13.5m ³
PS570-3 without leg extensions	210" 5334mm	46.5 sq. ft. 4.32m ²	106" 2692mm	32" 813mm	61-3/4" 1568mm	63-3/8" 1610mm	68" 1727mm	550°F 288°C	4- 29:50	5250 lbs. 2384kg	480 ft. ³ 13.5m ³
PS570-4 with outriggers	280" 7112mm	62 sq. ft. 5.76m ²	106" 2692mm	32" 813mm	61-3/4" 1568mm	63-3/8" 1610mm	82" 2083mm	550°F 288°C	4- 29:50	7000 lbs. 3178kg	640 ft. ³ 18.0m ³

ELECTRICAL SPECIFICATIONS

Model	Version   	Voltage	Phase/Freq.	Supply
PS570		208-240V	1/60 Hz	2 pole, 3 wire (2 hot, 1 gnd)
PS570		230V	1/50 Hz	2 pole, 3 wire (2 hot, 1 gnd)

Max Current Draw at Startup

Amps
12A*
10A*

Breakers

As per local codes
As per local codes

* The current draw ratings shown above are the max required at startup.
The average current draw during operation is significantly lower.

GAS SUPPLY SPECIFICATIONS

	Min. Gas Pipe Size	Supply Gas Pressure	Rated Heat Input
Natural Gas	2" (50.8mm) main One 1-1/4" (12.7mm) NPT branch to lower oven cavity with individual full-flow shutoff valve	6-12" W.C. (14.9-29.9 mbar)	170,000 BTU (42,840 kcal, 50 kW/hr.) per oven cavity
Propane Gas	2" (50.8mm) main One 1-1/4" (12.7mm) NPT branch to lower oven cavity with individual full-flow shutoff valve	11-14" W.C. (27.4-34.9 mbar)	170,000 BTU (42,840 kcal, 50 kW/hr.) per oven cavity

* The gas supply pressures shown are for ovens installed in North America. The required gas supply pressures of other locations are dependent on the local gas type and on all applicable local codes.

ALL SPECIFICATIONS SUBJECT TO CHANGE WITHOUT NOTICE.

KEY PARTS

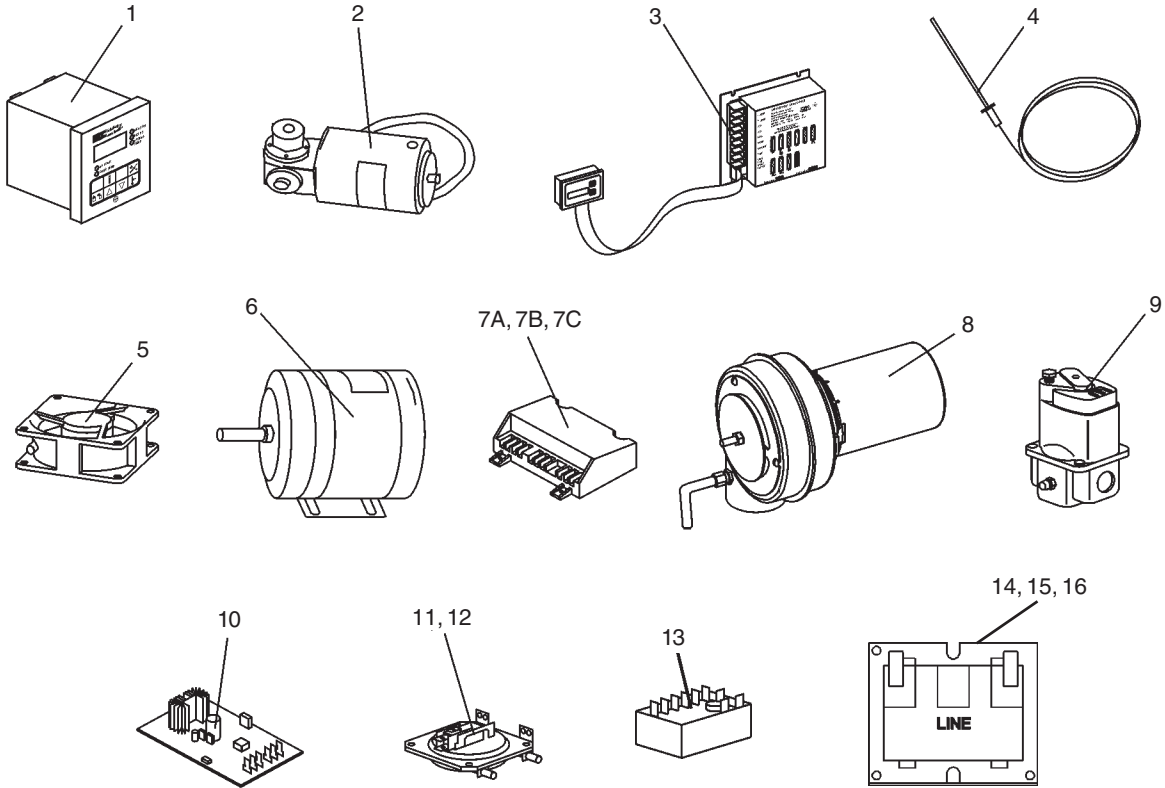

ITEM	PART NO.	DESCRIPTION	QUANTITY
1	47321	Kit, Digital Temperature Control (58504)	1
2	See Below 47796 51059	Motor, Drive 1400:1 (provided Standard) 600:1 (Hi-speed application)	1 or 2
3	58323	Kit, Conveyor Speed Controller with Digital Display	1 or 2
4	33984	Kit, Thermocouple (33812-1)	4
5	97525	Fan, Cooling	2
6	27381-0069	Motor, Blower, 1HP	2
7A	42810-0114	Ignition Module, US Version	1
7B	30872	Ignition Module, CE Version	1
7C	44676	Ignition Module, Australian Version	1
8	38811	Burner Blower/Motor Assembly	1
9	59450	Valve, Modulating Gas, 1/2" (41647)	1
10	31651	Amplifier, Modulating Valve	1
11	50610	Air Switch, Rear Blower(s)	2
12	57141	Air Switch, Front, Burner/Blower	1
13	33983	Hi Limit Control Module	1
14	31504	Transformer, 240/120V Conveyor System	1
15	41872	Transformer, 240/24V, 25VA	1
16	32108	Transformer, 240/24V, 65VA	1

View of INSTALLATION KIT

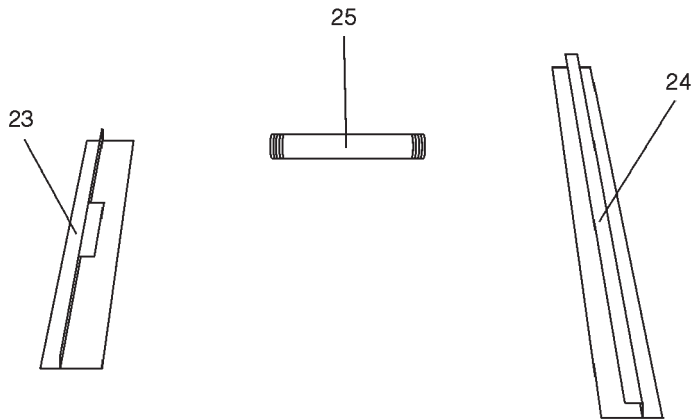

View of BASE PAD KIT

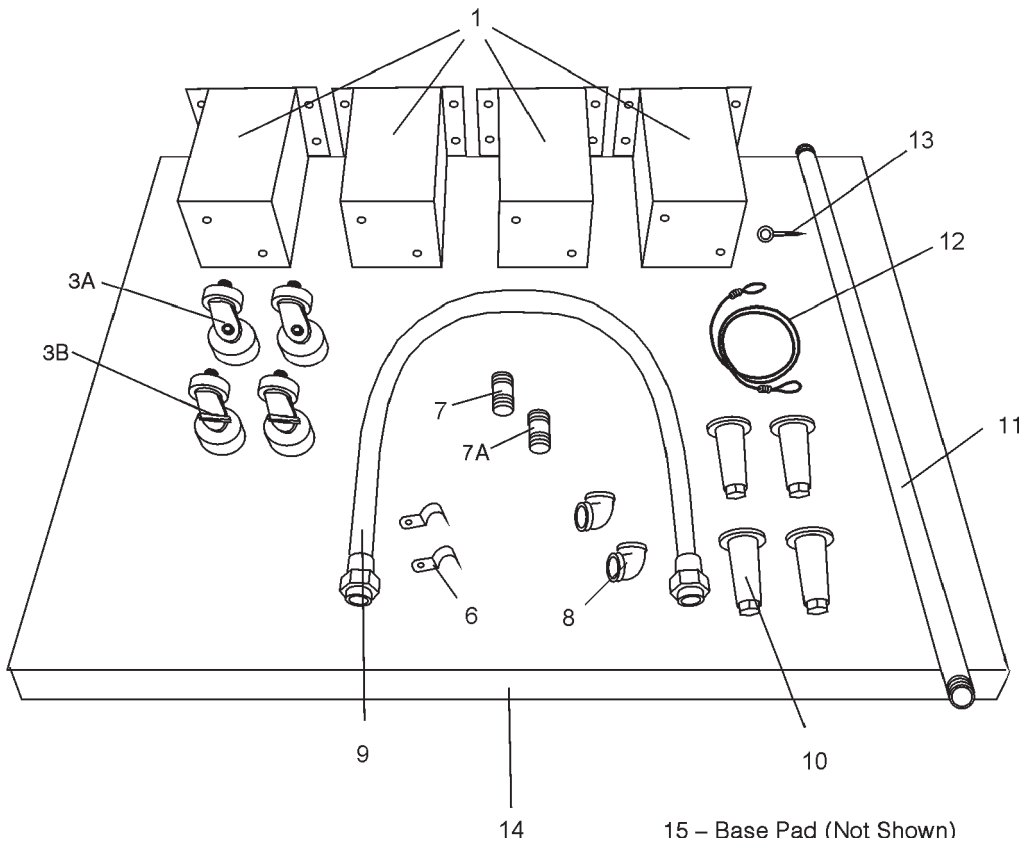

Parts for INSTALLATION KIT

ITEM	QTY.-SGL. BELT	P/N	DESCRIPTION
23	1	55028	CONVEYOR REAR STOP, 18"
24	1	55027	CONVEYOR END STOP, 29-1/4"
25	1	33120-0054	GAS PIPE NIPPLE, 1-1/4" X 6"

Parts for BASE PAD KIT

ITEM	QTY. SGL. OVEN 19" LEGS	QTY. SGL/DBL. OVEN/W 10" LEGS	QTY. SGL/DBL. OVEN/W 15" LEGS	QTY. TRIPLE OVEN	P/N	DESCRIPTION
1A	4	—	—	—	37210-0060	LEG, 19" (483mm) (OPTIONAL)
1B	—	4	—	—	37210-0082	LEG, 10" (254mm), No Longer Available
1C	—	—	4	—	37210-0057	LEG, 15" (381mm)
1D	—	—	—	4	39684	LEG, 4" (102mm) (43158, set of 4)
3A	2	2	2	2	37115-0102	CASTER, SWIVEL WITH 3/4" STUD
3B	2	2	2	2	58930	CASTER, SWIVEL WITH BRAKE
6	2	2	2	2	27271-0004	PIPE CLAMP, 1-1/2"
7	2	2	2	2	33120-0055	NIPPLE, 1-1/4" DIA. X 3" L, NPT
7A	1	1	1	1	33120-0054	PIPE, 1-1/4" DIA. X 6" L
8	2	2	2	2	23122-0007	ELBOW, 90°, 1-1/4" DIA.
9	1	1	1	1	22361-0003	GAS HOSE, 1-1/4" DIA. x 72" L
10	4	4	4	4	22450-0028	LEG, 6" (152mm) ADJUSTABLE WITH 3/4" STUD
11	1	1	1	1	33120-0056	GAS PIPE, 1-1/4" DIA. x 54" L
12	1	1	1	1	22450-0253	RESTRAINT CABLE, 60" (1524mm)
13	1	1	1	1	37699	EYE BOLT, BASE PAD
14	2	2	2	2	35210-0656	TOP COVER (RIGHT OR LEFT)
15	1	1	1	1	37210-0055	BASE PAD

NOT SHOWN:

—	8	8	8	8	59156	SCREW, TEKS HD #10-32 x 1-1/4"
—	2	2	2	2	21292-0001	SCREW, TEKS HWH #2PT #10-16 x 3/4"
—	16	16	16	—	21216-0018	BOLT, HEX CAP 1/2"-13 x 1-1/4"
—	16	16	16	—	21416-0003	FLAT WASHER, 1/2"
—	16	16	16	—	21426-0004	LOCK WASHER, 1/2"
—	1	1	1	1	21392-0005	EYE BOLT, WALL

View of PANELS, END PLUGS, WINDOW and LEGS

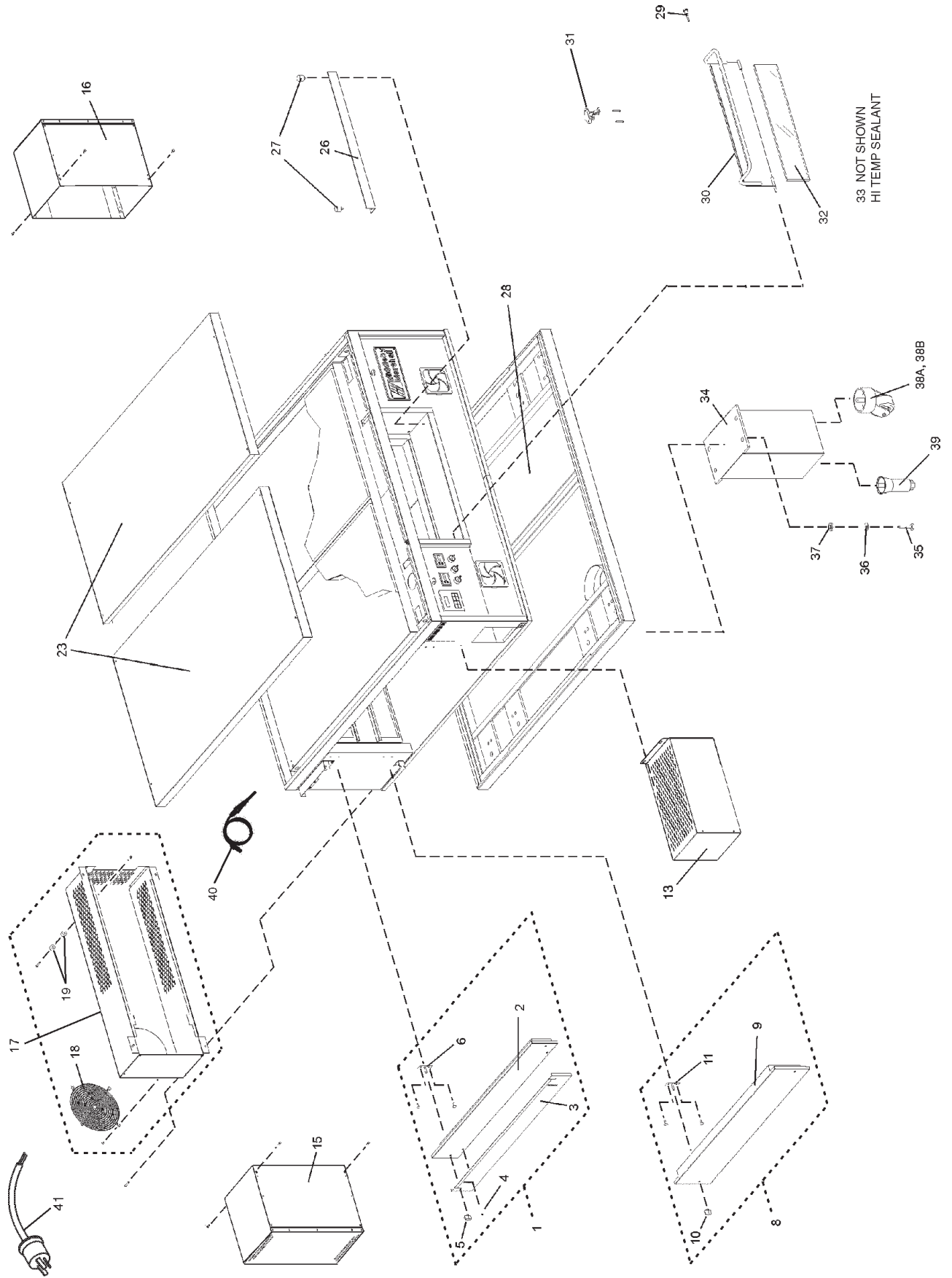

33 NOT SHOWN
HI TEMP SEALANT

Parts for PANELS, END PLUGS, WINDOW and LEGS

ITEM QTY.	P/N	DESCRIPTION
1 2	39539	ASSY, UPPER END PLUG (INC. ITEMS 2-6)
2 2	41778	WELDMENT, UPPER END PLUG PS500
3 1	50834	EYEBROW
4 8	220295	SCREW, "AB" HEX WSHR HD #10 X 3/4"
5 4	36452	WING NUT, 1/4"-20 W/PLASTIC GRIP
6 4	41708	PLATE, END PLUG MOUNTING
8 2	39569	ASSY, LOWER END PLUG (INC. ITEMS 9-11)
9 2	41779	WELDMENT, LOWER END PLUG PS500
10 4	36452	WING NUT, 1/4"-20 W/PLASTIC GRIP
11 4	41708	PLATE, END PLUG MOUNTING
13 1	44494	ASSEMBLY, DRIVE MOTOR SHROUD
15 1	44482	ASSEMBLY, LEFT MOTOR SHROUD
16 1	44483	ASSEMBLY, RIGHT MOTOR SHROUD
17 2	41679	ASSEMBLY, REAR SHROUD (INC. ITEM 18 and 19)
18 2	31765	GRILL, COOLING FAN
19 2	48522	BUMPER
23 2	35210-0656	TOP COVER

ITEM QTY.	P/N	DESCRIPTION
26 1	41768	WINDOW GUARD
27 2	30927	BUMPER, WINDOW
28 1	37210-0055	BASE PAD
29 1	34121-0003	SCREW, THUMB
30 1	45457	WINDOW ASSEMBLY WITH HATCH
31 1	45087	LATCH (INCLUDED IN ITEM 30)
32 1	44514	GLASS, WINDOW, PRE-CUT (INCLUDED IN ITEM 30), 3-1/2" x 32"
33 1	17130-0006	SEALANT
34A 4	37210-0060	LEG, SINGLE OVEN, 19" (483mm)
34B 4	37210-0057	LEG, DOUBLE OVEN, 15" (381mm)
34C 4	37210-0082	LEG, DOUBLE OVEN, 10" (254mm), NO LONGER AVAILABLE
34D 4	39684	LEG, 4" (43158, SET OF 4)
35 16	21216-0018	BOLT, HEX CAP 1/2"-13 X 1-1/4" - SINGLE & DOUBLE OVENS
36 16	21426-0004	LOCKWASHER, 1/2" - SGL & DBL OVENS
37 16	21416-0003	FLAT WASHER, 1/2" - SGL & DBL OVENS
38A 2	37115-0102	CASTER, SWIVEL WITH 3/4" STUD - SINGLE, DOUBLE, & TRIPLE OVENS
38B 2	58930	CASTER, SWIVEL WITH 3/4" STUD - SINGLE, DOUBLE, & TRIPLE OVENS WITH BRAKE
39 4	22450-0028	LEG, 6" (152mm) ADJUSTABLE WITH 3/4" STUD - SINGLE, DOUBLE, & TRIPLE OVENS
40 4	33984	KIT, THERMOCOUPLE, 6" (33812-1)
41A 1	49975	CORD AND PLUG, L6-20P
41B 1	49976	CE CORD

View(s) of FRONT CONTROL AREA(s)

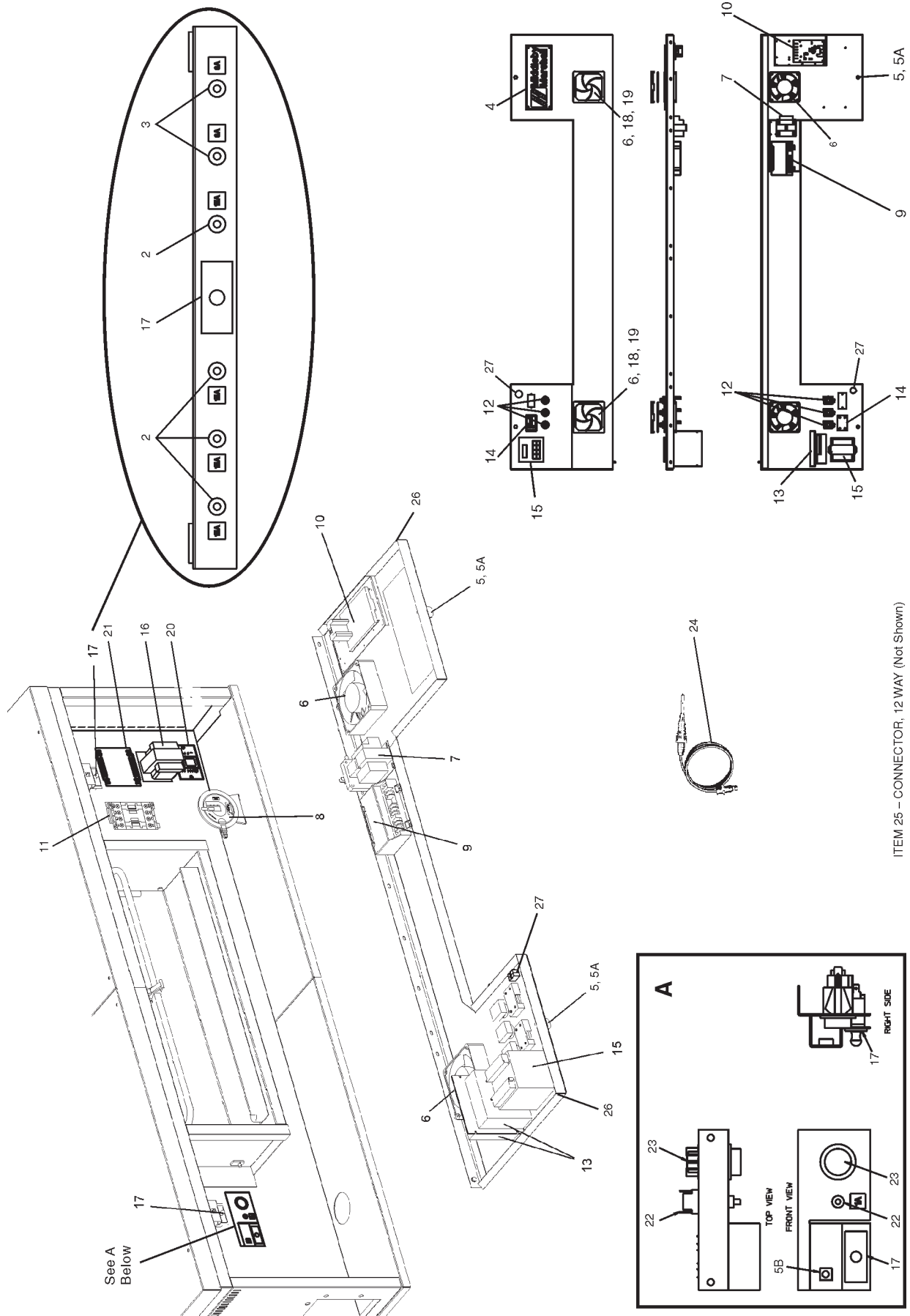

ITEM 25 - CONNECTOR, 12 WAY (Not Shown)

Parts for FRONT CONTROL AREA(s)

ITEM QTY.	P/N	DESCRIPTION
2	45037	CIRCUIT BREAKER, 15 AMP
3	45036	CIRCUIT BREAKER, 3 AMP
4	22500-0021	NAMEPLATE, "MIDDLEBY MARSHALL"
5	A6153	BOLT
5A	21182-0005	KEEPER
5B	21182-0006	SELF RETAINING NUT
6	97525	COOLING FAN, BLOWS IN
7	32108	TRANSFORMER, 240Vp;24Vs, 65VA
8	57141	AIR SWITCH; BURNER/BLOWER MOTOR, FRONT
9A	42810-0114	IGNITIONMODULE, US VERSION
9B	30872	IGNITIONMODULE, CE VERSION
9C	44676	IGNITIONMODULE, AUSTRALIAN VERSION
10	31651	SIGNAL AMPLIFIER; BOARD
11	28041-0011	CONTACTOR, BLOWER MOTORS
12	46521	KIT, SELECTOR SWITCH; CONTACT BLOCK
12A	44697	CONTACT BLOCK
12B	44696	SELECTOR SWITCH
13	58323	KIT, CONVEYOR SPEED CONTROLLER WITH SELECTOR AND DIGITAL DISPLAY (INC. ITEM 14)
14	37503	DIGITAL DISPLAY
15	47321	KIT, DIGITAL TEMPERATURE CONTROLLER (58504)

ITEM QTY.	P/N	DESCRIPTION
16	31504	TRANSFORMER, 230Vp;120Vs, 0.2 KVA, CONVEYOR
17	28021-0047	SAFETY SWITCH, MACHINERY COMPARTMENT ACCESS PANEL, INTERLOCK
18	310-2458	GRILL, COOLING FAN, WITH FILTER
19	310-2468	FILTER ONLY
20	33983	HI-LIMIT CONTROL
21	41872	TRANSFORMER, 240/24V, SIGNAL AMPLIFIER, 25VA
22	45644	CIRCUIT BREAKER, 1 AMP
23	35145	RESET BUTTON WITH GREEN LIGHT
24	33894	KIT, THERMOCOUPLE, 6" x 120" (33812-1)
25	32001	CONNECTOR, 12 WAY FOR P/N 30872 PACTROL /IGNITION MODULE (CE ONLY)
26	45020	CATCH, DOOR (CE ONLY)
CE ONLY		
27	28201-0016	LIGHTED RESTART SWITCH
27A	27073-0007	BULB, 220V
27B	30204	PUSH BUTTON
27C	30205	ADAPTER
27D	30206	CONTACT BLOCK
27E	30207	SOCKET FOR BULB

View of GAS PIPING AND BURNER ASSEMBLY

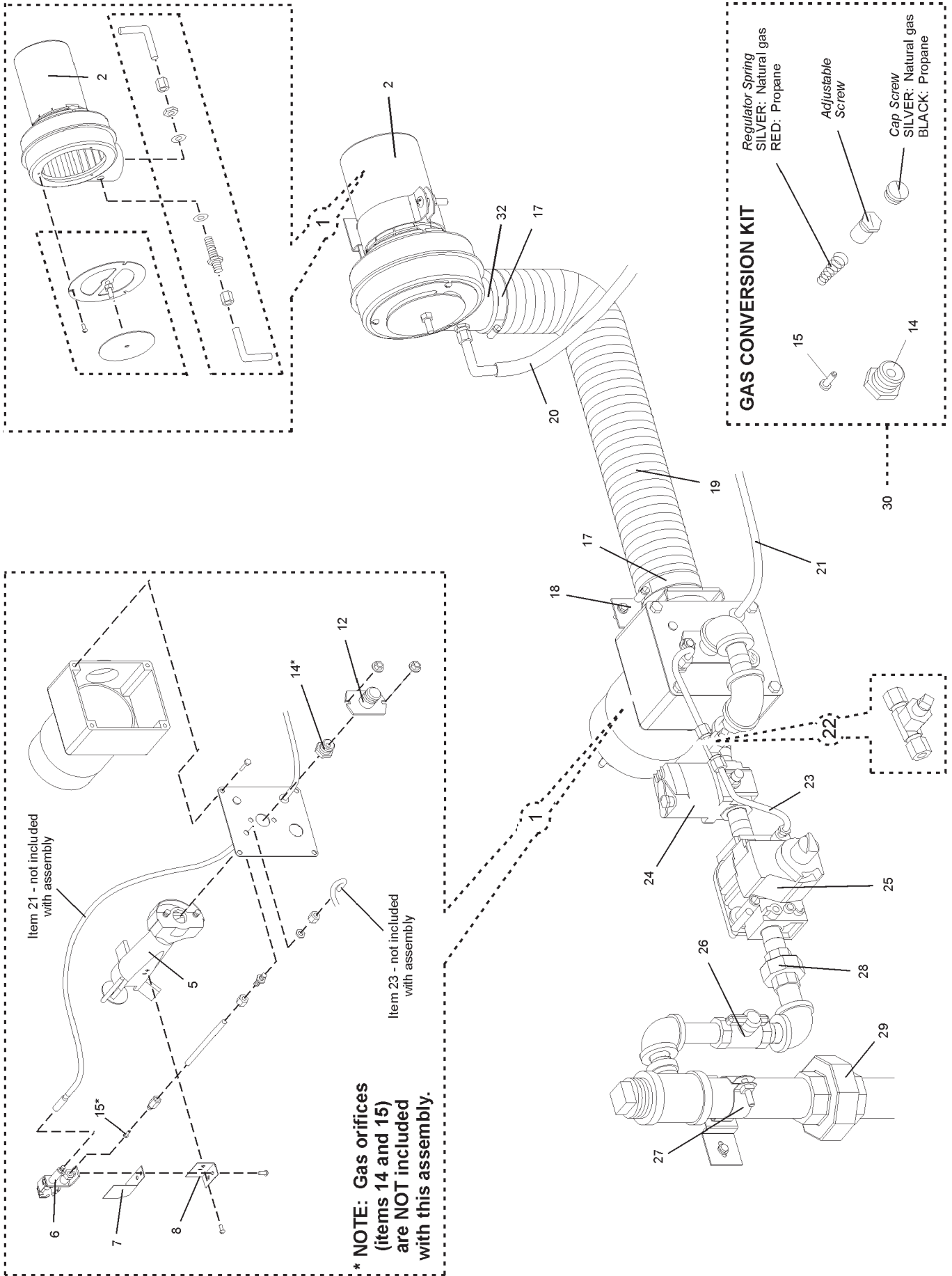

Item 21 - not included with assembly

Item 23 - not included with assembly

Parts for GAS PIPING AND BURNER ASSEMBLY

ITEM QTY.	P/N	DESCRIPTION	ITEM QTY.	P/N	DESCRIPTION
1	38126	ASSEMBLY, BURNER (INCLUDES ITEMS 1-12)	22	30185	KIT, PILOT TEE 1/4"/6.4mm
2	38811	ASSEMBLY, BURNER BLOWER AND MOTOR (INCLUDES ITEMS 2-4)	23	15125-0002	TUBING, ALUMINUM, 1/4"/6.4mm O.D.
5	38127	VENTURI	24	59450	VALVE, MODULATING GAS, 1/2" (41647)
6	27363-0002	PILOT IGNITOR WITH NATURAL GAS ORIFICE	25A	45688	COMBINATION GAS VALVE (SAFETY REGULATOR), 1/2", NATURAL GAS
7	27170-0204	PILOT SHIELD	25B	43085	COMBINATION GAS VALVE & GAS PRES-SURE SWITCH (CE ONLY), NATURAL GAS
8	27170-0264	BRACKET, PILOT MOUNTING	25C	28092-0018	KIT, COMBINATION VALVE, CONVERT NATURAL GAS TO LP, (INCLUDES CAP SCREW, O-RING, ADJUSTING SCREW AND LP SPRING)
12	38279	ORIFICE HOLDER/INLET CONNECTOR	26	23115-0009	VALVE, SHUTOFF 1/2"
14A	22176-0014	MAIN ORIFICE, NATURAL GAS, 0.250" (6.35mm)	27	42410-0016	BRACKET, PIPE MOUNTING 1-1/4"
14B	22176-0015	MAIN ORIFICE, PROPANE, 0.152" (3.86mm)	28	23051-0003	UNION, PIPE 1/2"
15A		USE ITEM 6 FOR NATURAL GAS	29	23051-0012	UNION, PIPE 1-1/4"
15B	22174-0010	PILOT ORIFICE, PROPANE, 0.018" (0.46mm)	30B	42810-0124	KIT, CONVERSION FROM NATURAL GAS TO PROPANE (INCLUDES ITEMS 14B, 15B AND 25C)
17	22450-0259	HOSE CLAMP	32	35210-0053	TUBE BLOWER EXTENSION (NOT SHOWN)
18	37210-0026	BRACKET, HOSE AND BURNER MOUNTING			
19	22450-0255	AIR DUCT, FLEXIBLE			
20	22450-0297	TUBING, SILICONE RUBBER, 1/4"/6.4mm DIA.			
21	27159-0019	IGNITION/SENSOR WIRE			

View(s) of REAR BLOWER/MOTOR ASSEMBLY (CONVEYOR DRIVE END SHOWN)

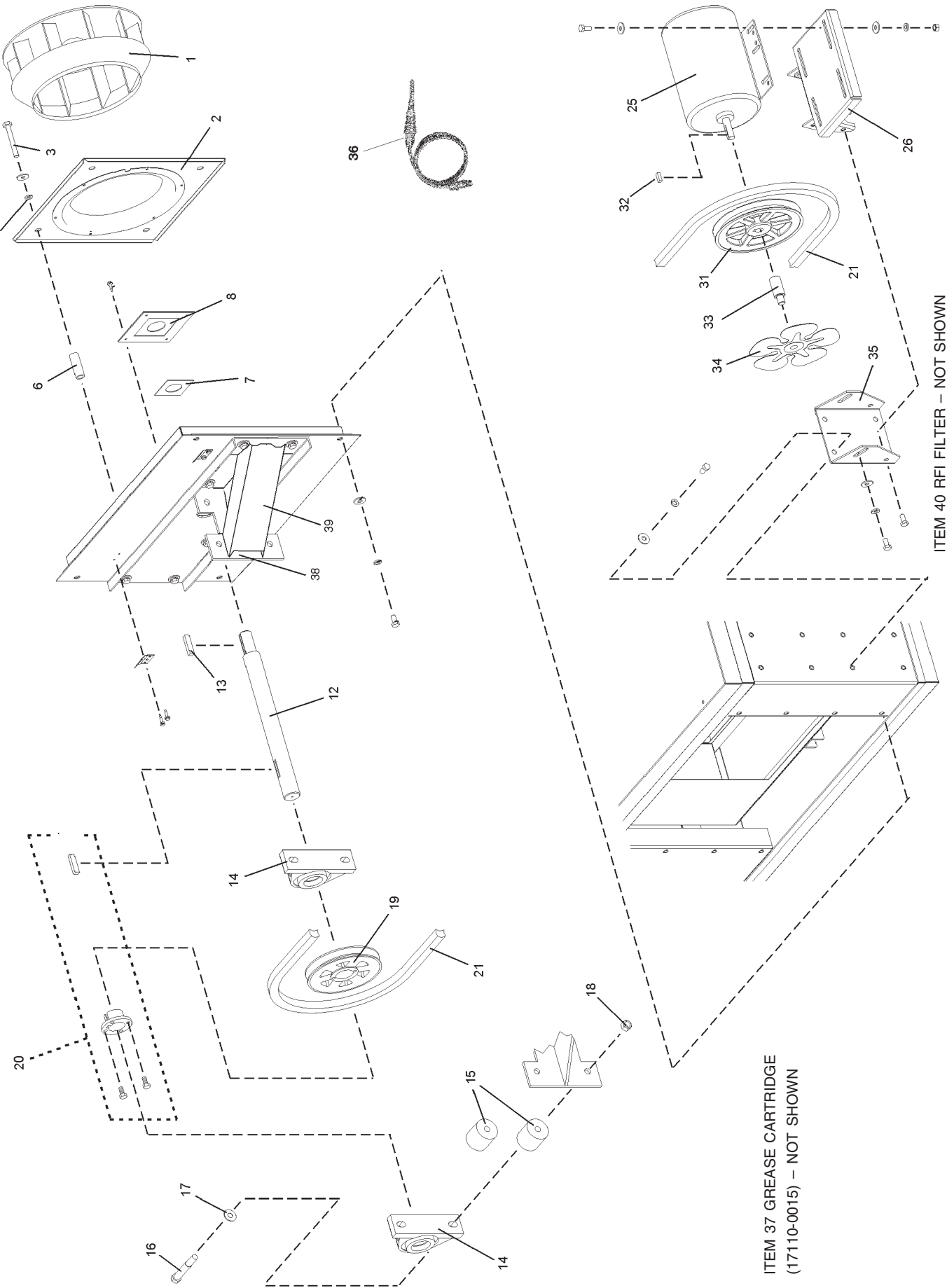

ITEM 37 GREASE CARTRIDGE
(17110-0015) - NOT SHOWN

ITEM 40 RFI FILTER - NOT SHOWN

Parts for EACH REAR BLOWER/MOTOR ASSEMBLY

ITEM QTY.	P/N	DESCRIPTION	ITEM QTY.	P/N	DESCRIPTION
1A 1	22521-0005	BLOWER WHEEL-CCW – DRIVE END	21 1	46452	BELT, STANDARD (SEE BELOW)
1B 1	22521-0006	BLOWER WHEEL-CW, IDLER END	25 1	27381-0069	MOTOR, BLOWER 1HP
2 1	37210-0124	PLATE, INLET RING	26 1	41666	BRACKET, MOTOR MOUNTING
3 4	21211-0001	SCREW, CAP HEX HD 3/8"-16 x 3"	31 1	47267	PULLEY, (BK65) STANDARD, MOTOR (SEE BELOW)
5 10	21422-0001	LOCKWASHER, SPLIT 3/8"	32 1	220026	KEY, PULLEY, 3/16" x 3/16" x 3/4" (5 x 5 x 19mm), MOTOR
6 4	35210-0576	SPACER	33 1	43024	EXTENDER, FAN
7 1	35210-0541	SHAFT SEAL, TEFLON	34A 1	27399-0008	FAN BLADE, CW, IDLER END
8 1	37210-0101	PLATE, SHAFT SEAL INNER	34B 1	27399-0009	FAN BLADE, CCW, CONVEYOR, DRIVE END
12 1	41899	SHAFT BLOWER	35 1	41667	BRACKET, MOTOR SUPPORT
13 1	35210-0286	KEY, BLOWER WHEEL	36 4	33984	KIT, THERMOCOUPLE, 6" (SOME MODELS HAVE A QTY OF 4) (33812-1)
14 2	57321	BEARING (22072-0017)	37 A/R	17110-0015	GREASE CARTRIDGE (FOR 22072-0017 BEARING)
15 4	39411	SPACER, BEARING	38 1	41575	MOUNTING BRACKET
16 4	2000535	SCREW, CAP HEX HD	39 1	44550	SUPPORT BRACKET
17 4	A6235	FLATWASHER, 7/16"	40 1	33813	RFI FILTER (CE & AUSTRALIAN ONLY)
17A 4	21422-0016	LOCKWASHER			
18 4	21121-0013	HEX NUT, 1/2"-13			
19 1	39587	PULLEY, BLOWER, STANDARD, 6-1/2"			
20 1	22031-0018	BUSHING, 2-1/2" DIAMETER			

RPM KIT P/N	HERTZ	MOTOR PULLEY W/SPLIT BUSHING	MTR PULLEY P/N SPLIT BUSH P/N	DIAMETER	BELT SIZE DESCRIPTION	BELT P/N	RPM OF FAN
47214 No Longer in Production	60	BK70	44977	6-3/4"	BX67	46452	1780
47215	60	BK80	39586	7-3/4"	BX68	46453	2057
47215	50	BK80	39586	7-3/4"	BX68	46453	1733
47216 Hi-Altitude	60	BK90H W/BUSHING	46455 50222	8-3/4"	BX70	46454	2300
47216 Hi-Altitude	50	BK90H W/BUSHING	46455 50222	8-3/4"	BX70	46454	1917
47268 Standard	60	BK65	47267	6-1/4"	BX67	46452	1692

View of REAR CAPACITOR AREA

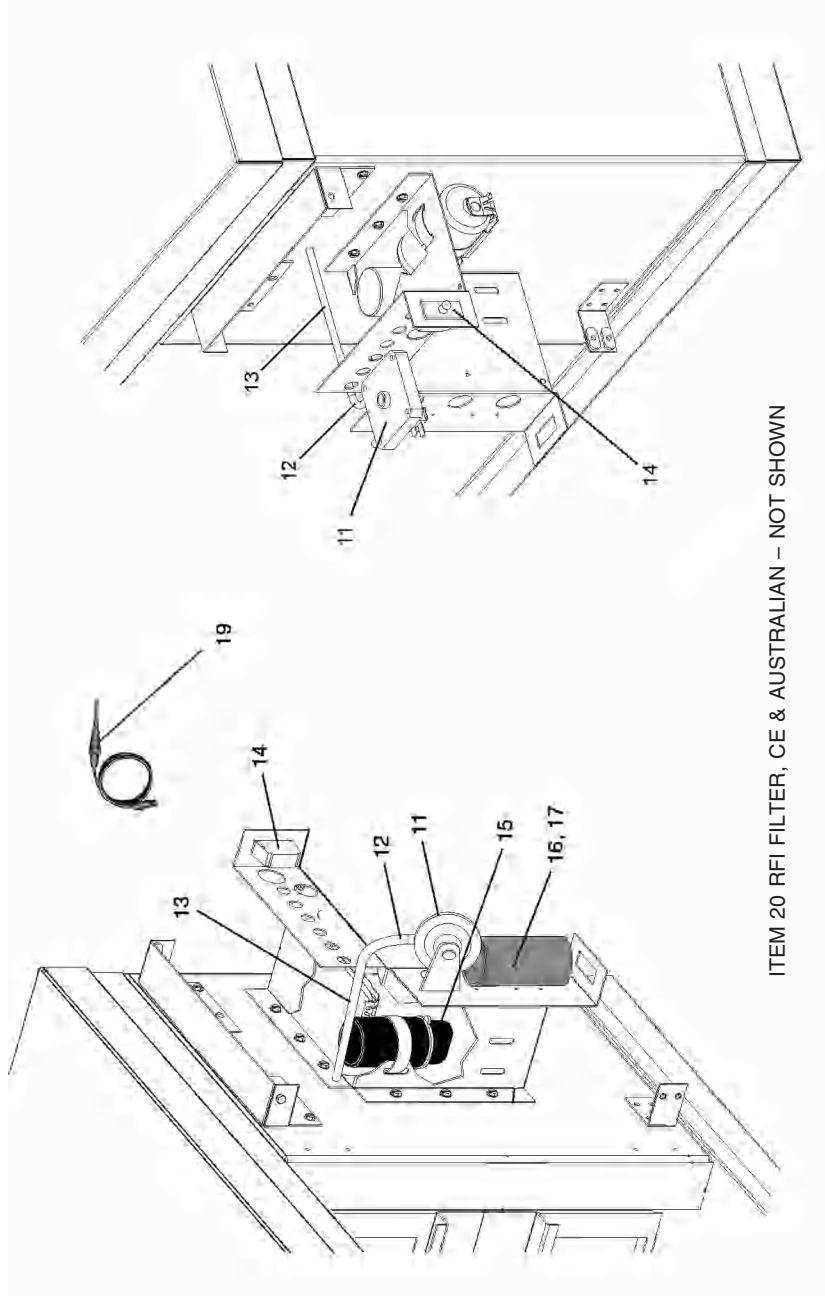

Parts for REAR CAPACITOR AREA

ITEM	QTY.	P/N	DESCRIPTION
11	2	50610	AIR SWITCH
12	A/R	22450-0297	TUBING, SILICONE BULK 1/4"/6.4mm O.D.
13	2	15125-0002	TUBING, ALUMINUM BULK 1/4"/6.4mm O.D.
14	2	28021-0061	SAFETY SWITCH, BLOWER MOTOR SHROUD, MOMENTARY
15	2	27170-0269	ASSEMBLY START CAPACITOR (BLACK)
15A	1	44469	BRACKET & END CAP, START CAPACITOR
16	2	27170-0270	CAPACITOR, RUN (SILVER)
17	2	44465	INSULATOR CAP, RUN CAPACITOR
18	4	22450-0259	HOSE CLAMP
19	3	33984	KIT, THERMOCOUPLE, 6' x 120" (33812-1) <i>(SOME MODELS HAVE A QTY OF 4)</i>
20	1	33813	RFI FILTER <i>(CE & AUSTRALIAN ONLY)</i>

View of "SINGLE" BELT CONVEYOR

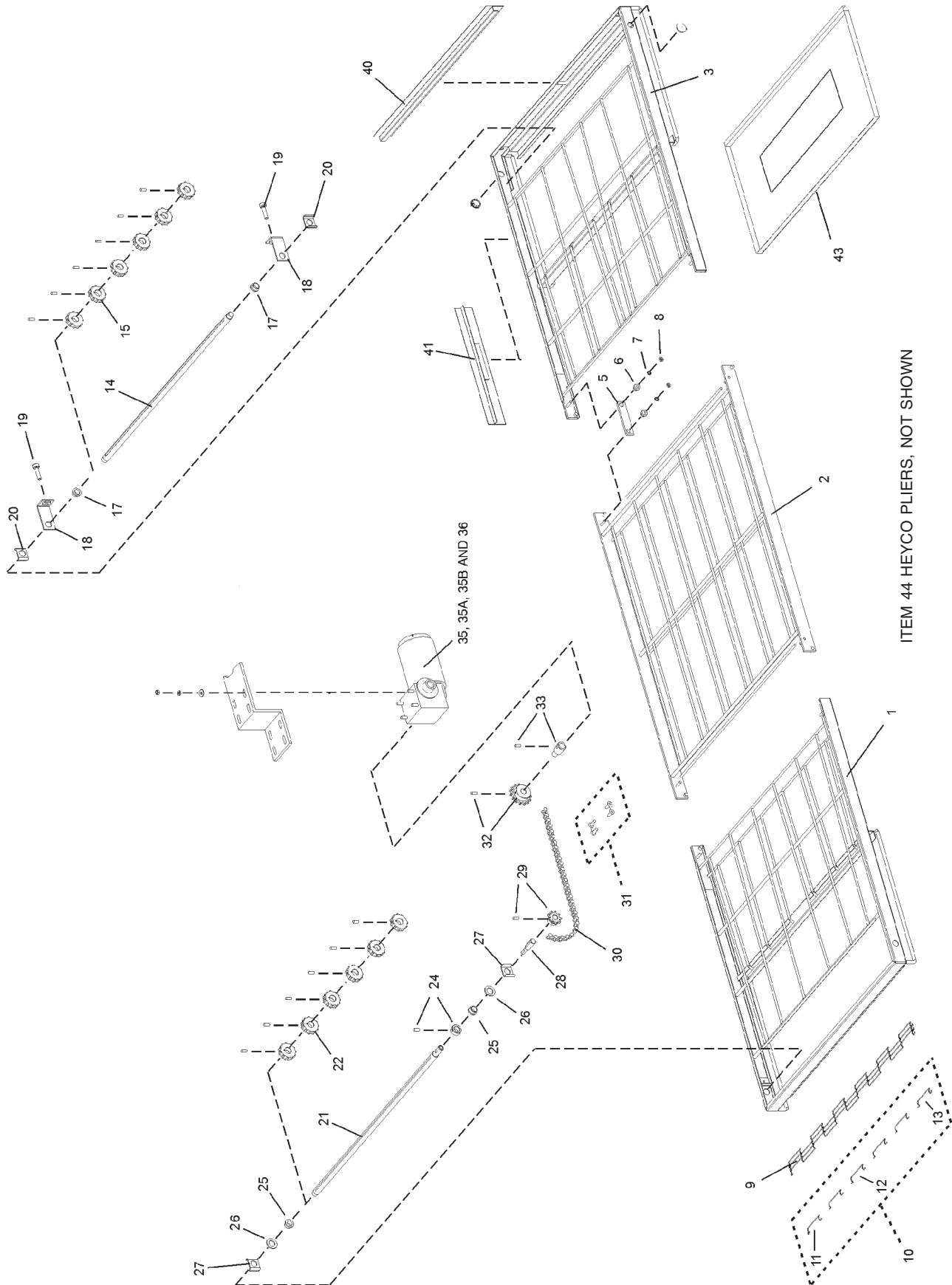

ITEM 44 HEYCO PLIERS, NOT SHOWN

Parts for "SINGLE" BELT CONVEYOR

ITEM	QTY	PART NO.	DESCRIPTION
1	1	37210-0117	WELDMENT, CONVEYOR DRIVE FRAME
2	4	37210-0046	WELDMENT, CONVEYOR CENTER FRAME
3	1	37210-0116	WELDMENT, CONVEYOR IDLER FRAME
5	4	35210-0429	PIVOT PLATE
6	8	35210-0491	BUSHING, CONVEYOR ADJUSTMENT
7	8	F716A8805	WASHER, EXTERNAL TOOTH 1/4"
8	8	21176-0001	LOCK NUT, HEX 1/4"-20
9A	1	22450-0265	CONVEYOR BELT, COMPLETE, 32"W x 206"L (0.81 x 5.23m)
9B	--	33900-0032	CONVEYOR BELT, 32"W x 12"L (0.81 x 0.30m)
10	1	42400-0089	MASTERLINKS KIT, 32" (0.81m) BELT (INC. ITEMS 11-13)
11	1	--	MASTERLINK, LEFT
12	4	--	MASTERLINK, CENTER
13	1	--	MASTERLINK, RIGHT
14	1	35000-1011	SHAFT, IDLER
15	6	22229-0003	SPROCKET, CONVEYOR BELT
17	2	22034-0003	BUSHING, BRONZE 3/4" O.D. x 5/8" I.D.
18	2	37000-0413	BRACKET, IDLER SHAFT ADJUSTMENT
19	2	35000-1008	SCREW, CONVEYOR TENSION ADJUSTMENT
20	2	54947	BRACKET, SHAFT SUPPORT
21	1	35000-1012	SHAFT, DRIVE
22	6	22229-0003	SPROCKET, CONVEYOR BELT
24	1	22011-0013	COLLAR, SHAFT, WITH SET SCREW

ITEM	QTY	PART NO.	DESCRIPTION
25	2	22034-0003	BUSHING, BRONZE 3/4" O.D. x 5/8" I.D.
26	2	35000-1080	SPACER, NYLON 1-1/4" O.D. x 3/4" I.D.
27	2	54947	BRACKET, SHAFT SUPPORT
28	1	35000-1013	ADAPTER, DRIVE SHAFT
29	1	22152-0017	SPROCKET, DRIVE SHAFT, 5/8" BORE, 9T, WITH SET SCREW
30	1	42400-0164	ASSEMBLY, ROLLER CHAIN (62 LINKS) WITH MASTERLINK (STANDARD SPEED)
31	1	22273-0001	MASTERLINK, ROLLER CHAIN
32A	1	22152-0018	SPROCKET, DRIVE MOTOR, 5/8" BORE, 15T, WITH SET SCREW (STANDARD SPEED)
32B	1	57319	SPROCKET, DRIVE MOTOR, 5/8", BORE, 20T (HIGH SPEED)
33	1	35210-0640	ADAPTER, DRIVE MOTOR WITH SET SCREW
35	1	47796	DRIVE MOTOR, 1/8 HP, 1400:1 (STANDARD)
35A	1	51059	DRIVE MOTOR, 1/8 HP, 600:1 (HIGH SPEED)
35B	1	SEE BELOW	BRUSHES, DRIVE MOTOR,
36	1	SEE BELOW	ASSEMBLY, PICKUP, DRIVE MOTOR
40	1	55027	END STOP, CONVEYOR, 29-1/4" LONG
41	1	55028	REAR STOP, CONVEYOR, 18" LONG
43	2	30004	CRUMB PAN, ALUMINIZED (WITH OPENINGS)
44	1	50795	TOOL, HEYCO PLIERS

CONVEYOR DRIVE MOTOR	MOTOR RATIO	ITEM 35B BRUSHES	ITEM 36 PICKUP SENSOR
CURRENT 47796	1400:1	45017	50265
46444	1400:1	46658	46451
46603	1400:1	46658	46451
27384-0008	1400:1	22450-0052	46451
CURRENT 51059	600:1	45017	50265
46446	600:1	46658	46451
46605	600:1	46658	46451
27384-0003	600:1	22450-0052	46451

View of "50-50" Split Belt Conveyor

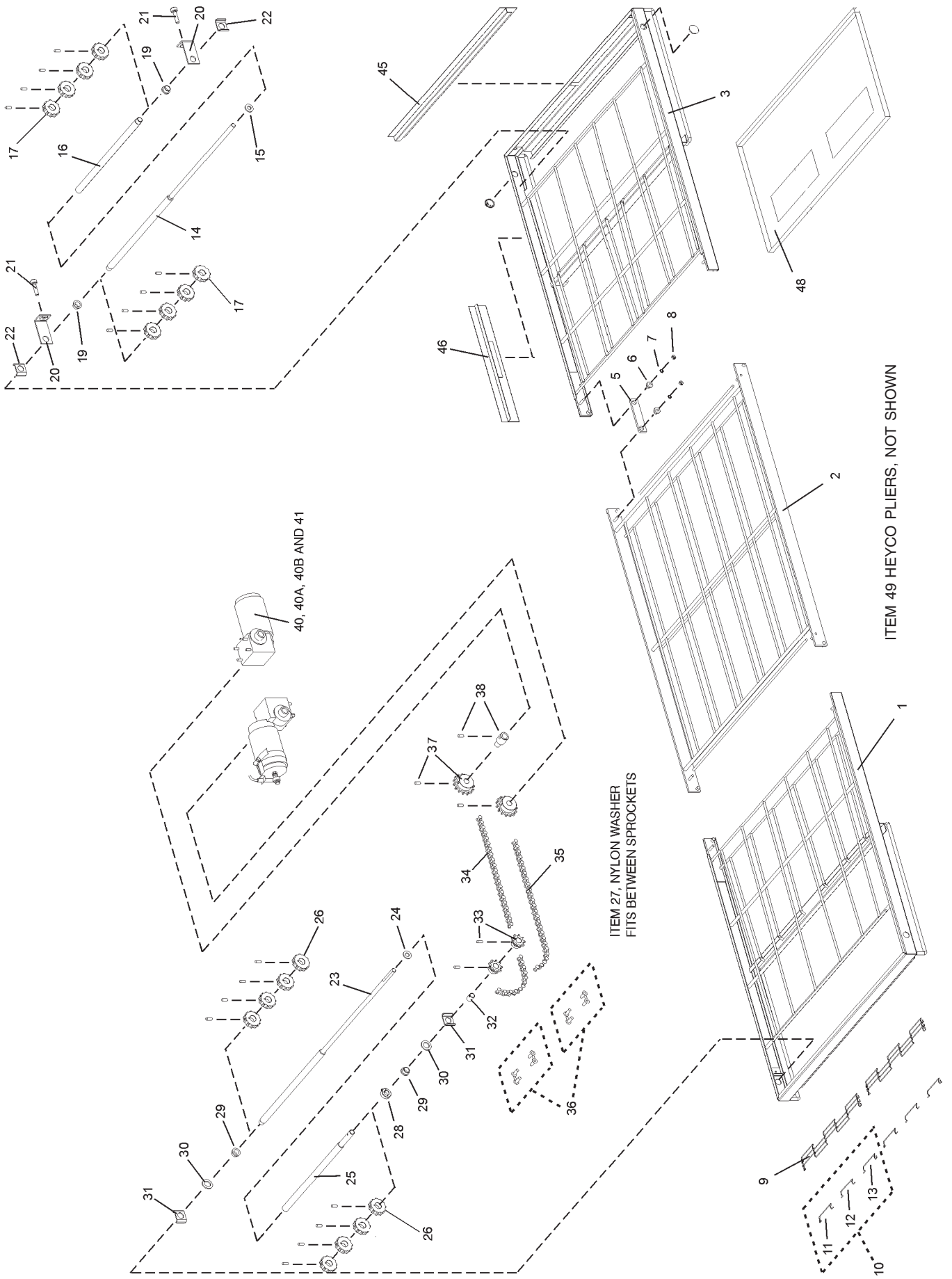

Parts for "50-50" Split Belt Conveyor

ITEM	QTY	PART NO.	DESCRIPTION
1	1	37210-0117	WELDMENT, CONVEYOR DRIVE FRAME
2	1	37210-0046	WELDMENT, CONVEYOR CENTER FRAME
3	1	37210-0116	WELDMENT, CONVEYOR IDLER FRAME
5	4	35210-0429	PIVOT PLATE
6	8	35210-0491	BUSHING, CONVEYOR ADJUSTMENT
7	8	F716A8805	WASHER, EXTERNAL TOOTH 1/4"
8	8	21176-0001	LOCK NUT, HEX 1/4"-20
9A	2	22450-0271	CONVEYOR BELT, COMPLETE, 15"W x 206"L (0.38 x 5.23m)
9B	--	33900-0037	CONVEYOR BELT, 15"W x 12"L (0.38 x 0.30m)
10	2	51382	MASTERLINKS KIT, 15" (0.81m) BELT (INC. ITEMS 11-13)
11	2	--	MASTERLINK, LEFT
12	2	--	MASTERLINK, CENTER
13	2	--	MASTERLINK, RIGHT
14	1	42400-0354	SHAFT, IDLER, REAR, 32-3/4"
15	1	21415-0001	FLAT WASHER, BRONZE, 1" O.D. X 1/2" I.D.
16	1	35000-1535	SHAFT, IDLER, FRONT, 16-3/8"
17	8	22229-0003	SPROCKET, CONVEYOR BELT
19	2	22034-0003	BUSHING, BRONZE 3/4" O.D. x 5/8" I.D.
20	2	37000-0413	BRACKET, IDLER SHAFT ADJUSTMENT
21	2	35000-1008	SCREW, CONVEYOR TENSION ADJUSTMENT
22	2	54947	BRACKET, SHAFT SUPPORT
23	1	42400-0355	SHAFT, DRIVE, REAR, 35-1/3"
24	1	21415-0001	FLAT WASHER, BRONZE, 1" O.D. X 1/2" I.D.
25	1	35000-1536	SHAFT, DRIVE, FRONT, 17-3/4"
26	8	22229-0003	SPROCKET, CONVEYOR BELT
27	1	35000-1531	SPACER, NYLON FITS BETWEEN SPROCKETS
28	1	22011-0014	COLLAR, SPLIT LOCKING
29	2	22034-0003	BUSHING, BRONZE 3/4" O.D. x 5/8" I.D.
30	2	35000-1080	SPACER, NYLON 1-1/4" O.D. x 3/4" I.D.

ITEM	QTY	PART NO.	DESCRIPTION
31	2	54947	BRACKET, SHAFT SUPPORT
32	1	35900-0023	BUSHING, SPLIT BELT DRIVE SPROCKET
33	2	22152-0017	SPROCKET, DRIVE SHAFT, 5/8" BORE, 9T, WITH SET SCREW
34	1	42400-0164	ASSEMBLY, ROLLER CHAIN COMPLETE (62 LINKS) (STANDARD SPEED)
35	1	42410-0128	ASSEMBLY, ROLLER CHAIN COMPLETE (48 LINKS) (STANDARD SPEED)
36	2	22273-0001	MASTERLINK, ROLLER CHAIN
37A	2	22152-0018	SPROCKET, DRIVE MOTOR, 5/8" BORE, 15T, WITH SET SCREW
37B	2	57319	SPROCKET, DRIVE MOTOR, 5/8", BORE, 20T (HIGH SPEED)
38	1	35210-0640	ADAPTER, DRIVE MOTOR WITH SET SCREW
40	2	47796	DRIVE MOTOR, 1/8 HP, 1400:1 (STANDARD)
40A	2	51059	DRIVE MOTOR, 1/8 HP, 600:1 (HIGH SPEED)
40B	2	SEE BELOW	BRUSHES, DRIVE MOTOR,
41	2	SEE BELOW	ASSEMBLY, PICKUP, DRIVE MOTOR
45	1	55027	END STOP, CONVEYOR, 29-1/4" LONG
46	1	55028	REAR STOP, CONVEYOR, 18" LONG
48A	2	30004	CRUMB PAN, ALUMINIZED (WITH OPENINGS)
49	1	50795	TOOL, HEYCO PLIERS

CONVEYOR DRIVE MOTOR	MOTOR RATIO	ITEM 40B BRUSHES	ITEM 41 PICKUP SENSOR
CURRENT 47796	1400:1	45017	50265
46444	1400:1	46658	46451
46603	1400:1	46658	46451
27384-0008	1400:1	22450-0052	46451
CURRENT 51059	600:1	45017	50265
46446	600:1	46658	46451
46605	600:1	46658	46451
27384-0003	600:1	22450-0052	46451

Standard Finger Configuration and Parts

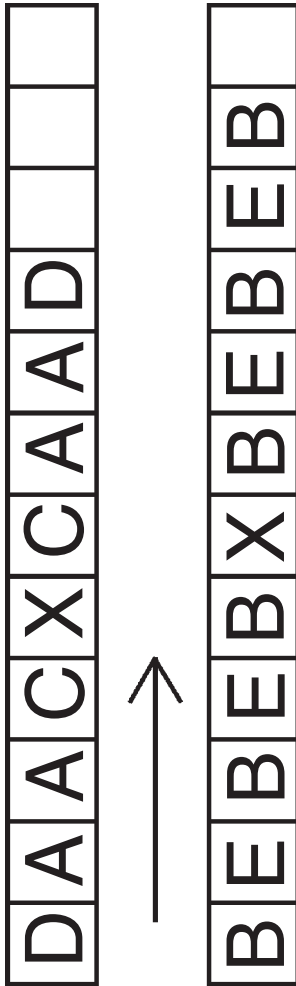

- A** = 39224 WLDMT, PLT OTR SL3 W/RASD MANF
37000-0577 WLDMT, PLATE, INNER COL W/DAM
42410-0202 ASSY, RAISED MANF W/SLD BAFFEL
- B** = 37900-0051 PLATE, OUTER S/L6
37000-0577 WLDMT, PLATE, INNER COL W/DAM
42410-0194 ASSY, MANIFOLD W/FULL BAFFEL ALUZ
- C** = 35210-0536 PLATE, FULL BLANK ALUZ
- D** = 35210-0535 PLATE, BLANK PRTL 2.75 UPR 570
- E** = 35210-0590 PLATE, BLANK PARTIAL ALUZ LWR570
- F** =
- G** =

Notes

RT TO LT MIRROR IMAGE OF FINGER ARRANGEMENT
 MOTOR PULLEY: BK65 P/N 47267
 BELT SIZE: BX67 P/N 46452
 RPM= 1692

Description

CONFIG, FINGER PS570S STD

P/N	Rev.
31257	K



Wiring Diagrams (electrical schematics)

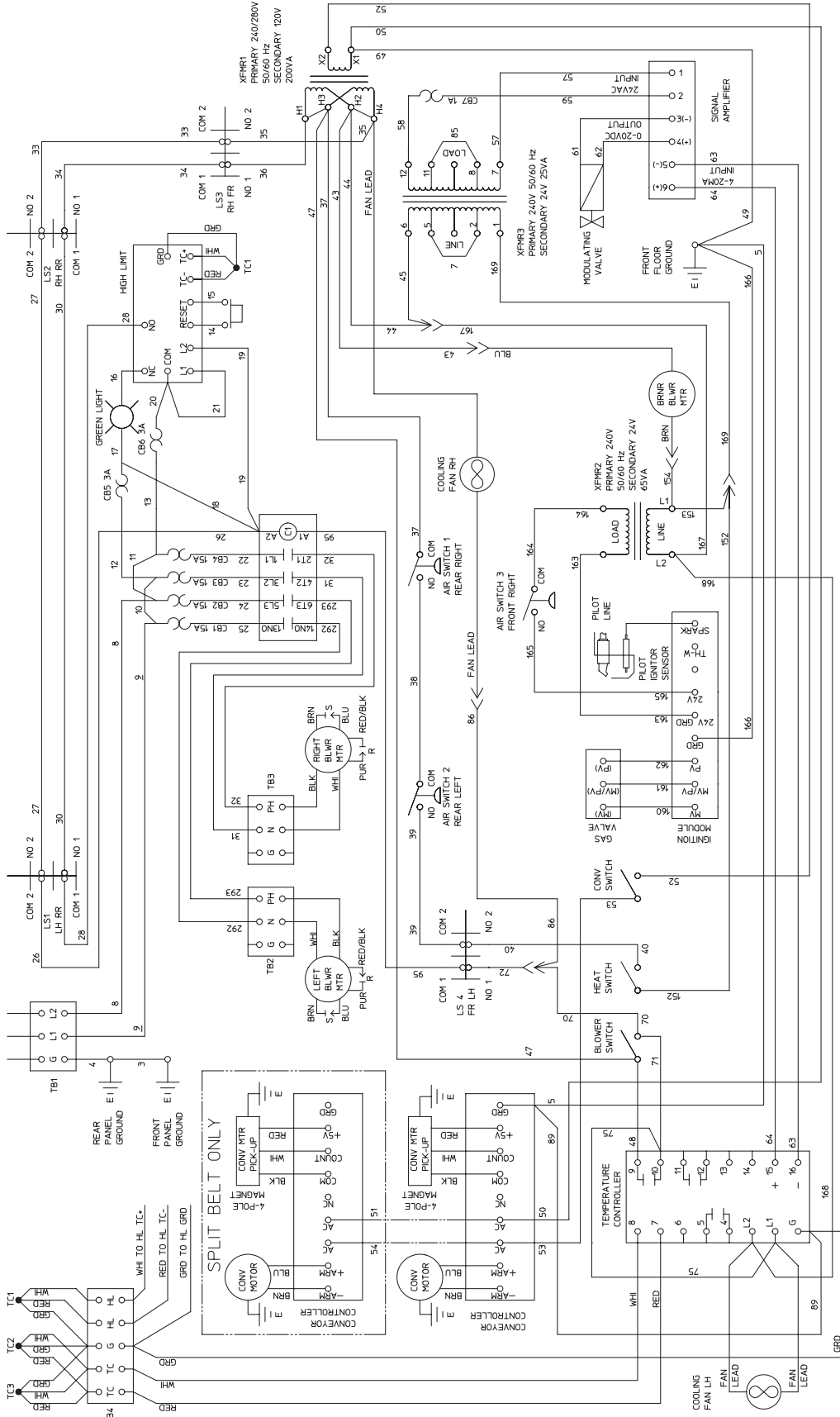

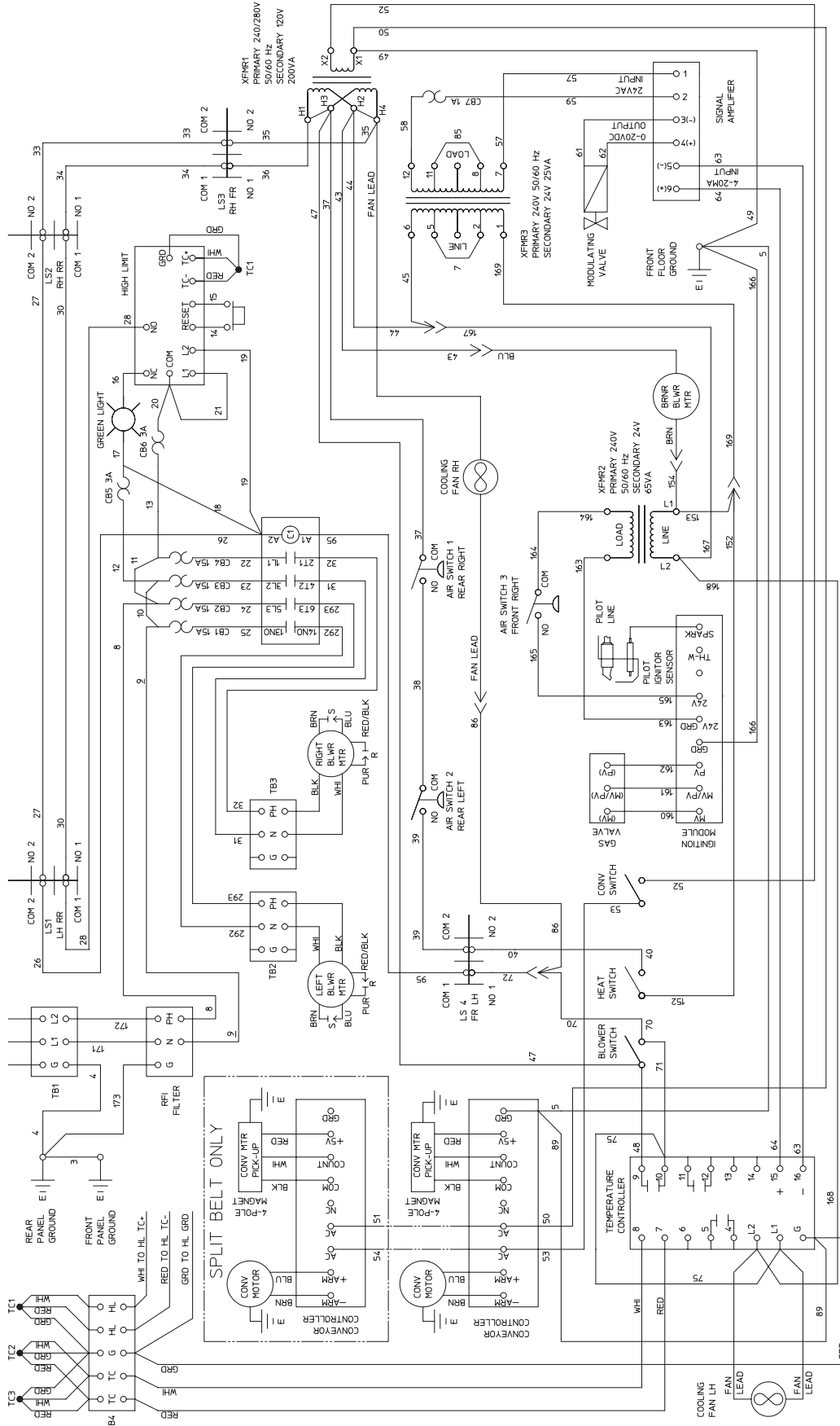

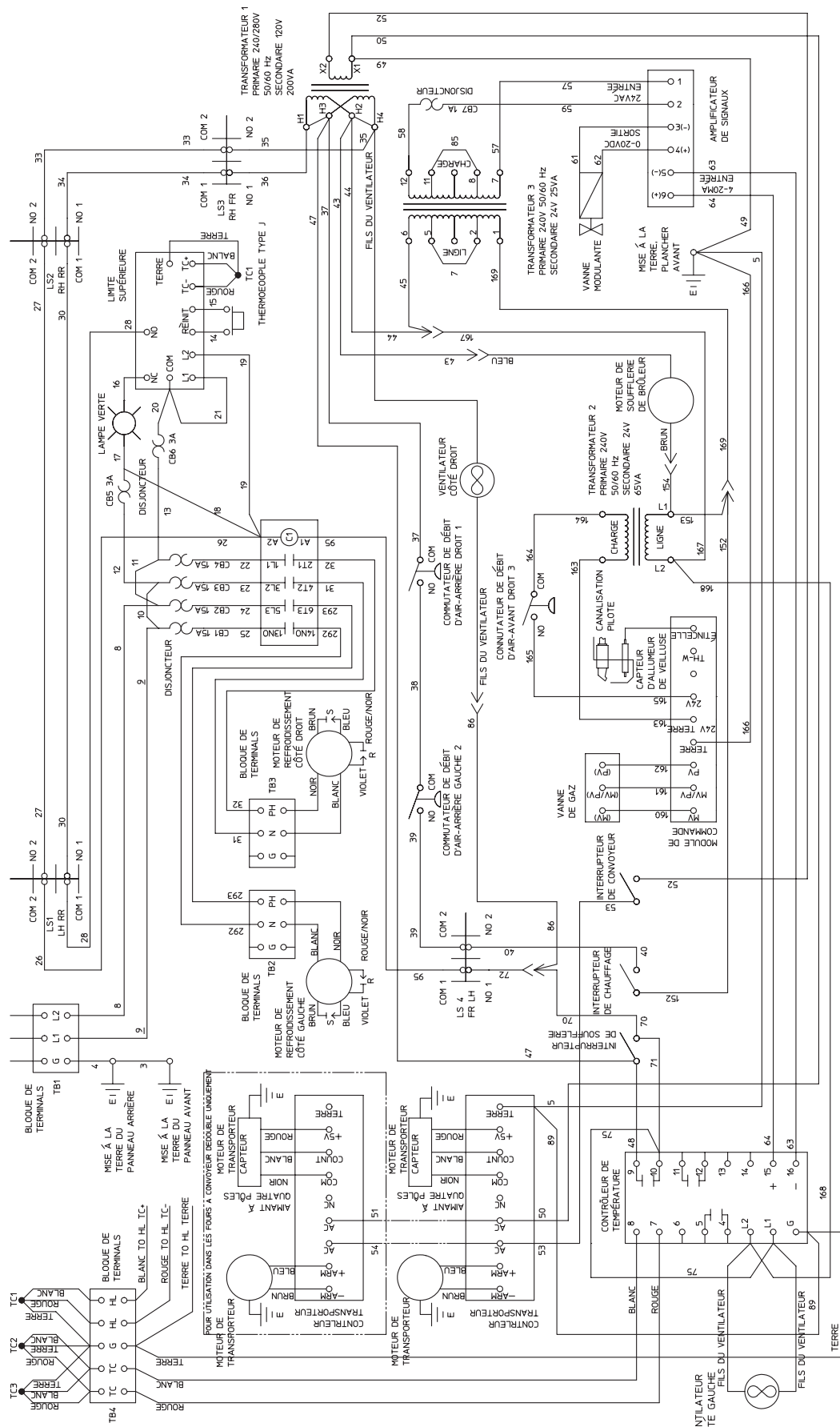

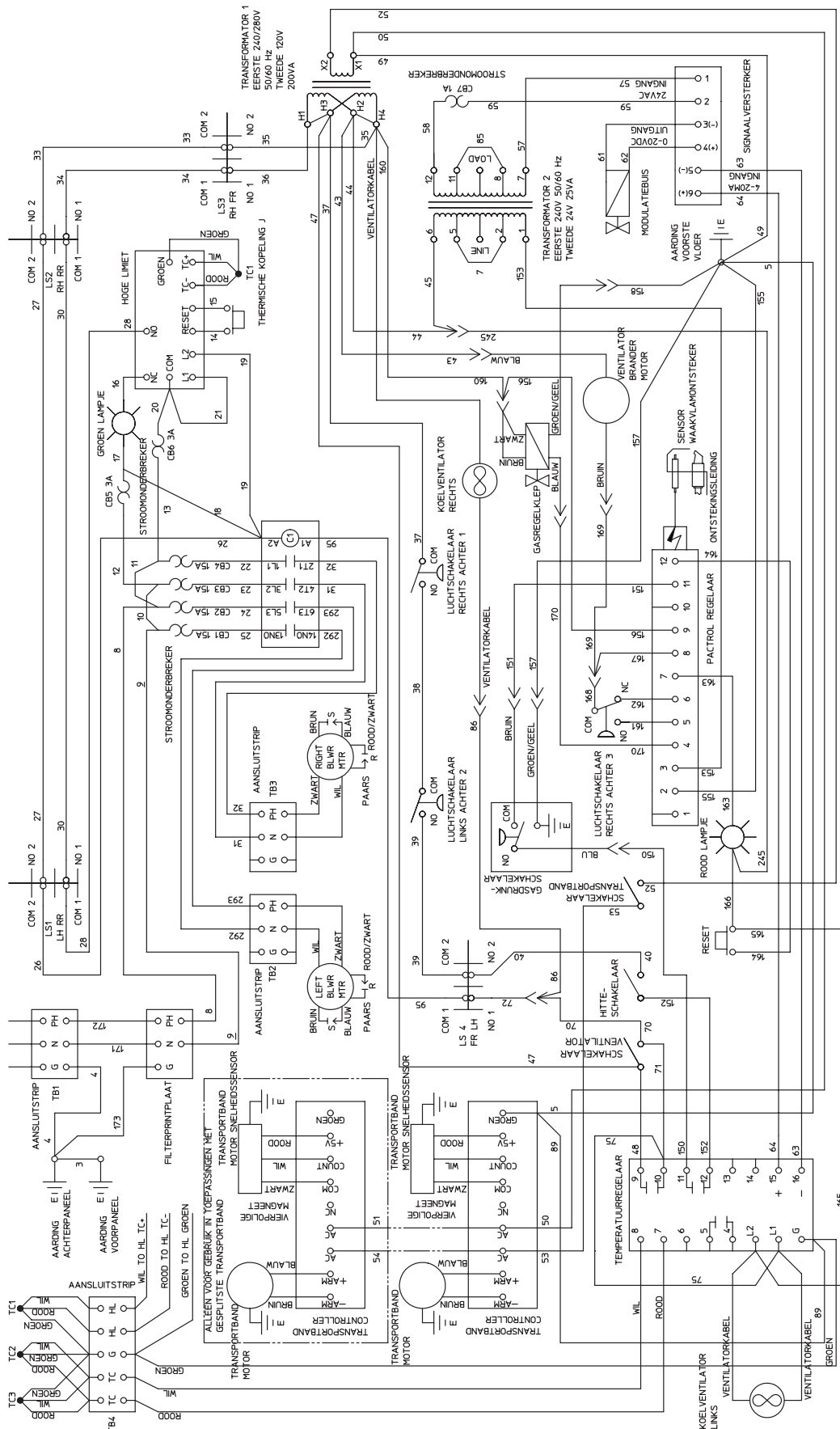

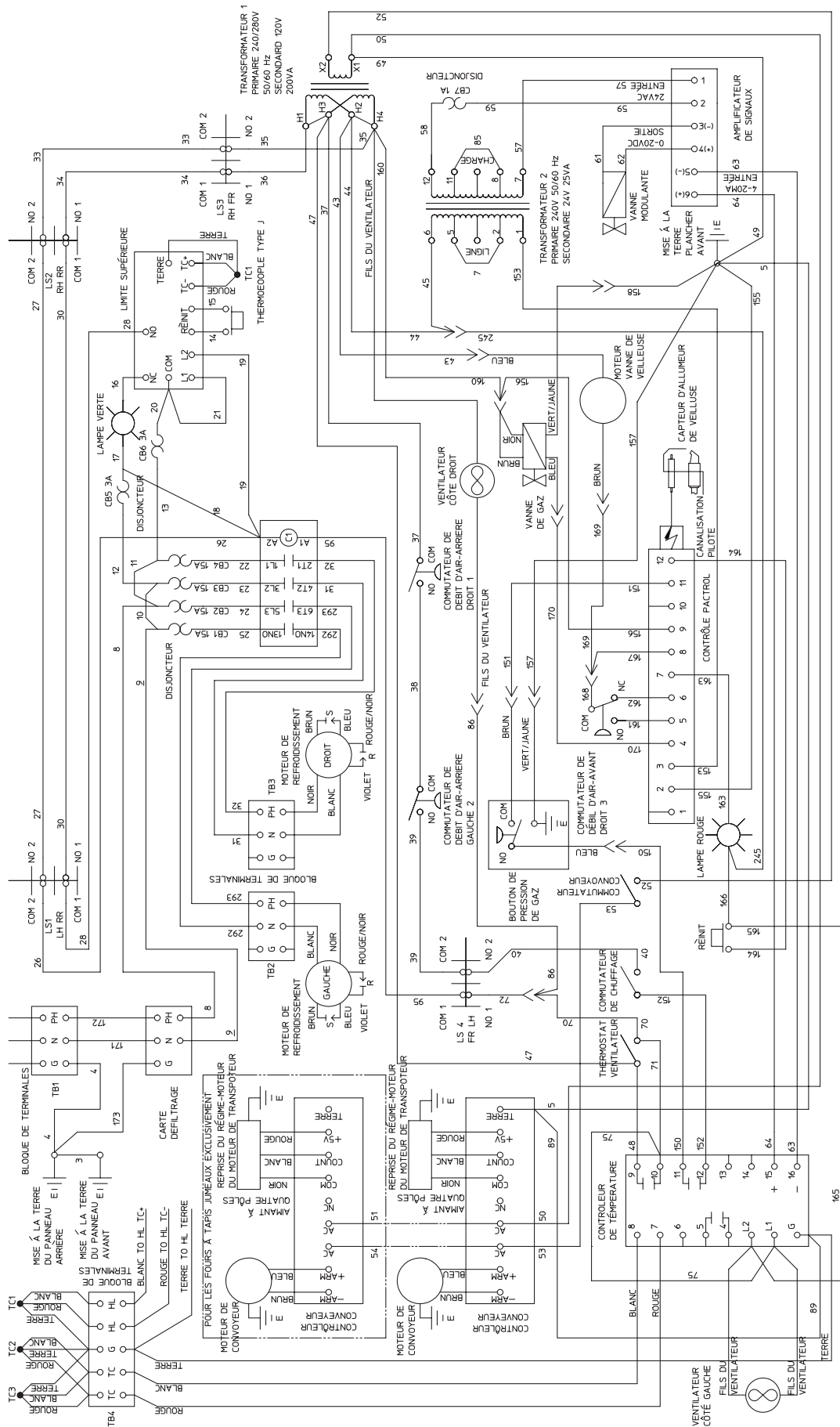

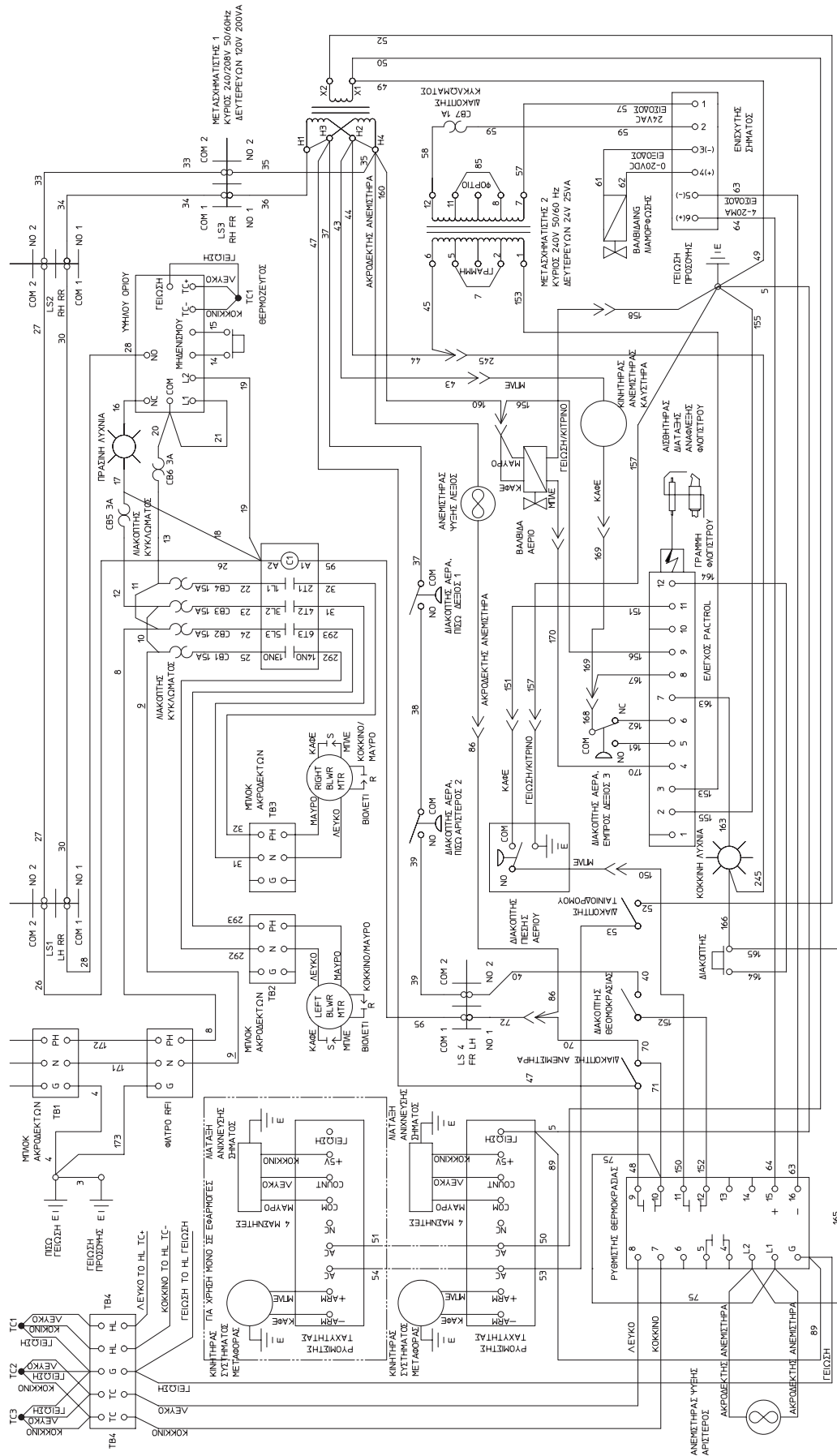

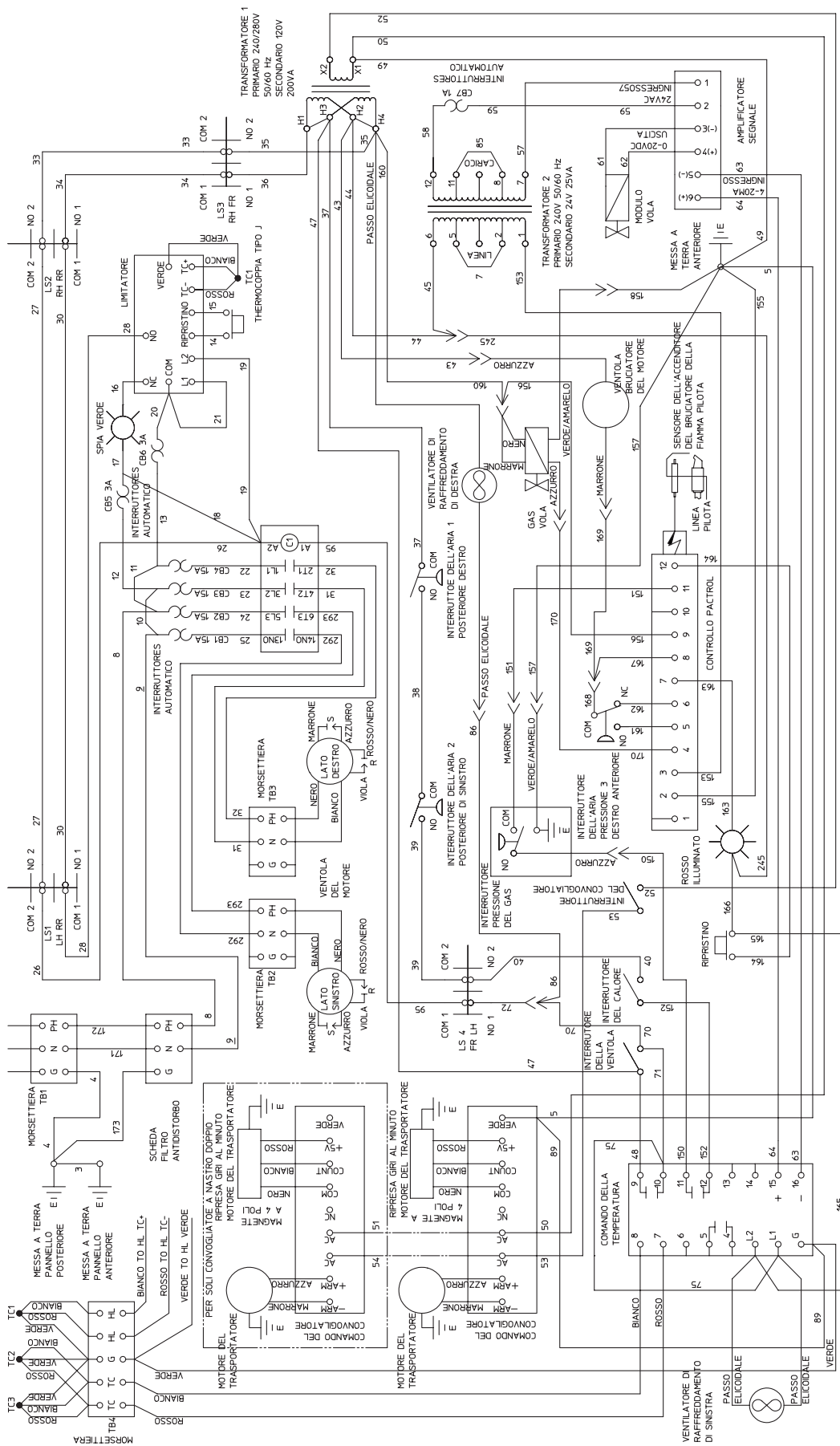

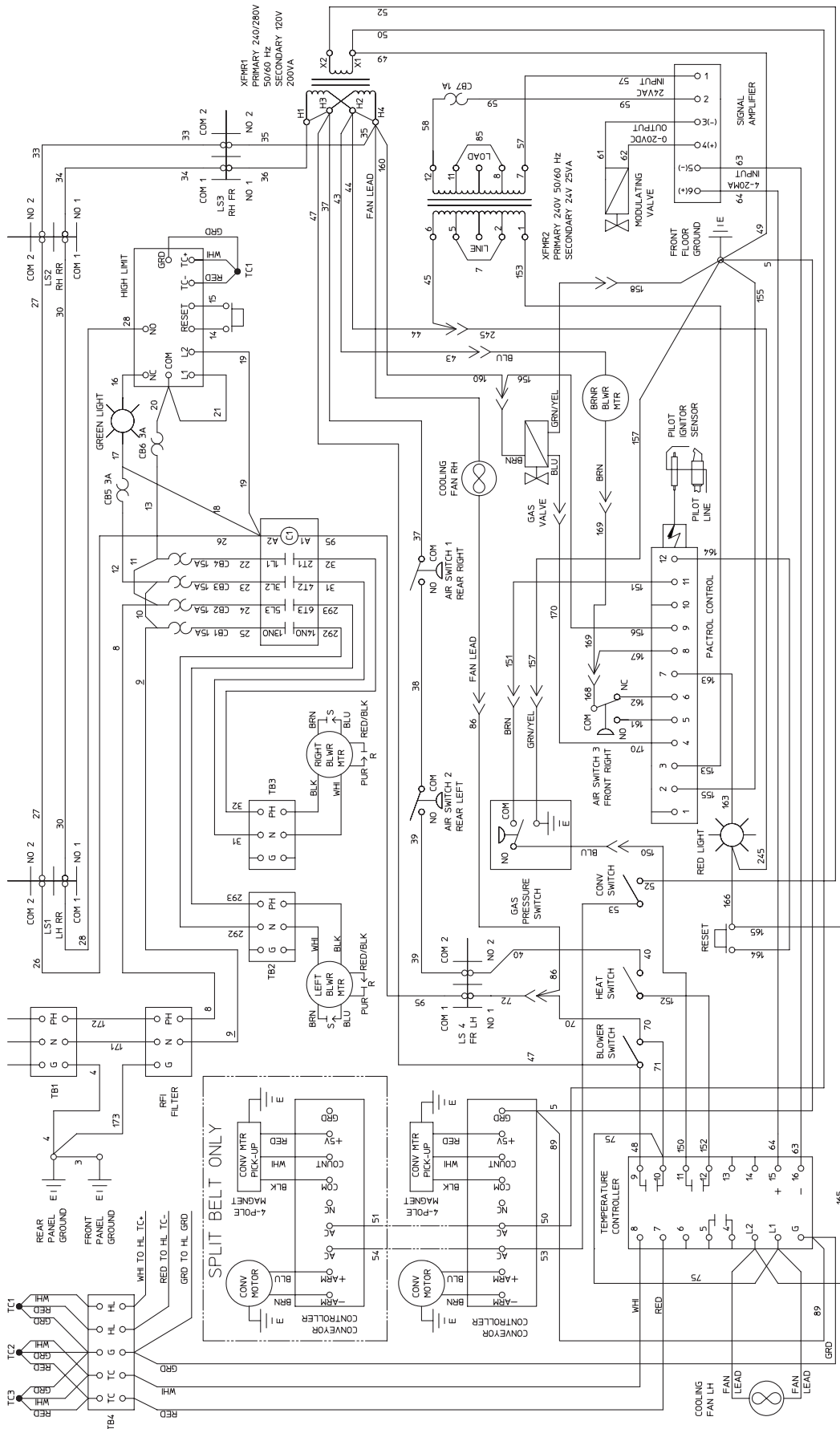

NOTES

NOTES

