

# ACS800

## Hardware Manual

ACS800-04 and ACS800-04M Drive Modules (45 to 560 kW)

ACS800-U4 Drive Modules (60 to 600 HP)

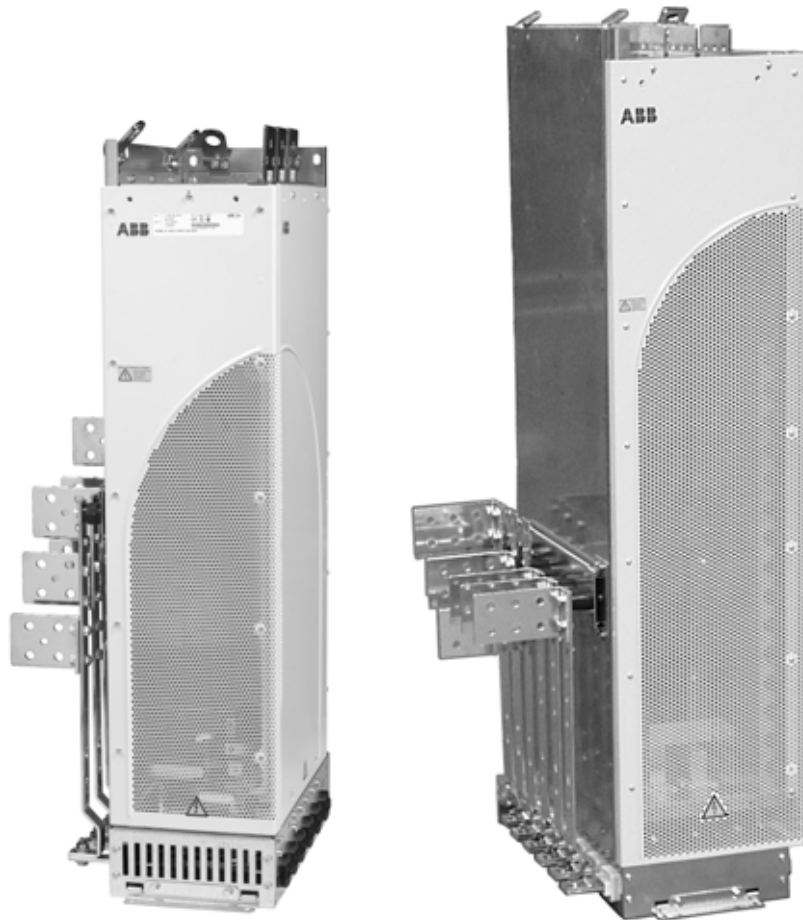

# ABB

# ACS800 Single Drive Manuals

**HARDWARE MANUALS** (appropriate manual is included in the delivery)

---

ACS800-01/U1 Hardware Manual 0.55 to 110 kW (0.75 to 150 HP)  
3AFE64382101 (English)

ACS800-01/U1 Marine Supplement 3AFE64291275 (English)

ACS800-02/U2 Hardware Manual 90 to 500 kW (125 to 600 HP)  
3AFE64567373 (English)

ACS800-04 Hardware Manual 0.55 to 132 kW  
3AFE68372984 (English)

ACS800-04/04M/U4 Hardware Manual 45 to 560 kW (60 to 600 HP)  
3AFE64671006 (English)

ACS800-04/04M/U4 Cabinet Installation 45 to 560 kW (60 to 600 HP)  
3AFE68360323 (English)

ACS800-07/U7 Hardware Manual 45 to 560 kW (50 to 600 HP)  
3AFE64702165 (English)

ACS800-07/U7 Dimensional Drawings 45 to 560 kW (50 to 600 HP)  
3AFE64775421

ACS800-07 Hardware Manual 500 to 2800 kW  
3AFE64731165 (English)

ACS800-17 Hardware Manual 75 to 1120 kW  
3AFE64681338 (English)

- Safety instructions
- Electrical installation planning
- Mechanical and electrical installation
- Motor control and I/O board (RMIO)
- Maintenance
- Technical data
- Dimensional drawings
- Resistor braking

## **FIRMWARE MANUALS, SUPPLEMENTS AND GUIDES**

(appropriate documents are included in the delivery)

---

Standard Application Program Firmware Manual  
3AFE64527592 (English)

System Application Program Firmware Manual  
3AFE63700177 (English)

Application Program Template Firmware Manual  
3AFE64616340 (English)

Master/Follower 3AFE64590430 (English)

PFC Application Program Firmware Manual  
3AFE64649337 (English)

Extruder Control Program Supplement 3AFE64648543 (English)

Centrifuge Control Program Supplement 3AFE64667246 (English)

Traverse Control Program Supplement 3AFE64618334 (English)

Crane Control Program Firmware Manual 3BSE11179 (English)

Adaptive Programming Application Guide  
3AFE64527274 (English)

## **OPTION MANUALS** (delivered with optional equipment)

---

Fieldbus Adapters, I/O Extension Modules etc.

ACS800-04 and ACS800-04M Drive Modules  
45 to 560 kW  
ACS800-U4 Drive Modules  
60 to 600 HP

**Hardware Manual**

3AFE64671006 Rev E EN  
EFFECTIVE: 19.11.2004



# Safety instructions

---

## What this chapter contains

This chapter contains the safety instructions which you must follow when installing, operating and servicing the drive. If ignored, physical injury or death may follow, or damage may occur to the drive, motor or driven equipment. Read the safety instructions before you work on the unit.

## To which products this chapter applies

This chapter applies to the ACS800-01/U1, ACS800-11/U11, ACS800-02/U2 and ACS800-04/04M/U4 of frame sizes R7 and R8.

## Use of warnings and notes

There are two types of safety instructions throughout this manual: warnings and notes. Warnings caution you about conditions which can result in serious injury or death and/or damage to the equipment. They also tell you how to avoid the danger. Notes draw attention to a particular condition or fact, or give information on a subject. The warning symbols are used as follows:



**Dangerous voltage warning** warns of high voltage which can cause physical injury and/or damage to the equipment.



**General warning** warns about conditions, other than those caused by electricity, which can result in physical injury and/or damage to the equipment.



**Electrostatic discharge warning** warns of electrostatic discharge which can damage the equipment.

## Installation and maintenance work

These warnings are intended for all who work on the drive, motor cable or motor.



**WARNING!** Ignoring the following instructions can cause physical injury or death, or damage to the equipment:

- **Only qualified electricians are allowed to install and maintain the drive.**
- Never work on the drive, motor cable or motor when main power is applied. After disconnecting the input power, always wait for 5 min to let the intermediate circuit capacitors discharge before you start working on the drive, motor or motor cable.

Always ensure by measuring with a multimeter (impedance at least 1 Mohm) that:

1. voltage between drive input phases U1, V1 and W1 and the frame is close to 0 V.
  2. voltage between terminals UDC+ and UDC- and the frame is close to 0 V.
- Do not work on the control cables when power is applied to the drive or to the external control circuits. Externally supplied control circuits may cause dangerous voltages inside the drive even when the main power on the drive is switched off.
  - Do not make any insulation or voltage withstand tests on the drive or drive modules.
  - When reconnecting the motor cable, always check that the phase order is correct.

**Note:**

- The motor cable terminals on the drive are at a dangerously high voltage when the input power is on, regardless of whether the motor is running or not.
- The brake control terminals (UDC+, UDC-, R+ and R- terminals) carry a dangerous DC voltage (over 500 V).
- Depending on the external wiring, dangerous voltages (115 V, 220 V or 230 V) may be present on the terminals of relay outputs RO1 to RO3.
- ACS800-02 with enclosure extension: The main switch on the cabinet door does not remove the voltage from the input busbars of the drive. Before working on the drive, isolate the whole drive from the supply.
- The Prevention of Unexpected Start function does not remove the voltage from the main and auxiliary circuits.

## Grounding

These instructions are intended for all who are responsible for the grounding of the drive.



---

**WARNING!** Ignoring the following instructions can cause physical injury, death, increased electromagnetic interference and equipment malfunction:

- Ground the drive, motor and adjoining equipment to ensure personnel safety in all circumstances, and to reduce electromagnetic emission and pick-up.
- Make sure that grounding conductors are adequately sized as required by safety regulations.
- In a multiple-drive installation, connect each drive separately to protective earth (PE).
- ACS800-01, ACS800-11: In European CE compliant installations and in other installations where EMC emissions must be minimized, make a 360° high frequency grounding of cable entries in order to suppress electromagnetic disturbances. In addition, connect the cable shields to protective earth (PE) in order to meet safety regulations.

ACS800-04 (45 to 560 kW) in first environment: make a 360° high frequency grounding of motor cable entries at the cabinet lead-through.

(ACS800-02: 360° high frequency grounding of cable entries is not required at the drive end.)

- Do not install a drive with EMC filter option +E202 or +E200 (available for ACS800-01 and ACS800-11 only) on an ungrounded power system or a high-resistance-grounded (over 30 ohms) power system.

**Note:**

- Power cable shields are suitable for equipment grounding conductors only when adequately sized to meet safety regulations.
  - As the normal leakage current of the drive is higher than 3.5 mA AC or 10 mA DC (stated by EN 50178, 5.2.11.1), a fixed protective earth connection is required.
-

## Mechanical installation and maintenance

These instructions are intended for all who install and service the drive.



**WARNING!** Ignoring the following instructions can cause physical injury or death, or damage to the equipment:

- Handle the unit carefully.
- ACS800-01, ACS800-11: The drive is heavy. Do not lift it alone. Do not lift the unit by the front cover. Place the unit only on its back.

ACS800-02, ACS800-04: The drive is heavy. Lift the drive by the lifting lugs only. Do not tilt the unit. The unit will overturn from a tilt of about 6 degrees. Use extreme caution when manoeuvring a drive that runs on wheels. **An overturning unit can cause physical injury.**

Do not tilt!

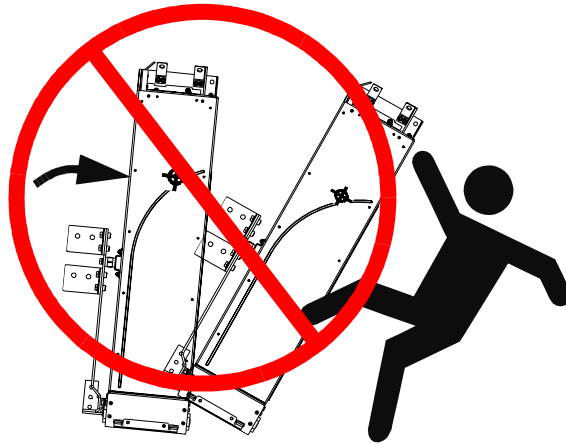

- Beware of hot surfaces. Some parts, such as heatsinks of power semiconductors, remain hot for a while after disconnection of the electrical supply.
- Make sure that dust from drilling does not enter the drive when installing. Electrically conductive dust inside the unit may cause damage or malfunctioning.
- Ensure sufficient cooling.
- Do not fasten the drive by riveting or welding.



### Printed circuit boards

---



**WARNING!** Ignoring the following instructions can cause damage to the printed circuit boards:

- The printed circuit boards contain components sensitive to electrostatic discharge. Wear a grounding wrist band when handling the boards. Do not touch the boards unnecessarily.
- 

### Fibre optic cables

---



**WARNING!** Ignoring the following instructions can cause equipment malfunction and damage to the fibre optic cables:

- Handle the fibre optic cables with care. When unplugging optic cables, always grab the connector, not the cable itself. Do not touch the ends of the fibres with bare hands as the fibre is extremely sensitive to dirt. The minimum allowed bend radius is 35 mm (1.4 in.).
-



## Operation

These warnings are intended for all who plan the operation of the drive or operate the drive.



---

**WARNING!** Ignoring the following instructions can cause physical injury or death, or damage to the equipment:

- Before adjusting the drive and putting it into service, make sure that the motor and all driven equipment are suitable for operation throughout the speed range provided by the drive. The drive can be adjusted to operate the motor at speeds above and below the speed provided by connecting the motor directly to the power line.
- Do not activate automatic fault reset functions of the Standard Application Program if dangerous situations can occur. When activated, these functions will reset the drive and resume operation after a fault.
- Do not control the motor with the disconnecting device (disconnecting means); instead, use the control panel keys  and , or commands via the I/O board of the drive. The maximum allowed number of charging cycles of the DC capacitors (i.e. power-ups by applying power) is five in ten minutes.
- Do not use the optional Prevention of Unexpected Start function for stopping the drive when the drive is running. Give a Stop command instead.

**Note:**

- If an external source for start command is selected and it is ON, the drive (with Standard Application Program) will start immediately after fault reset unless the drive is configured for 3-wire (a pulse) start/stop.
  - When the control location is not set to Local (L not shown in the status row of the display), the stop key on the control panel will not stop the drive. To stop the drive using the control panel, press the LOC/REM key and then the stop key .
-

## Permanent magnet motor

These are additional warnings concerning permanent magnet motor drives. Ignoring the instructions can cause physical injury or death, or damage to the equipment.

### Installation and maintenance work

---



**WARNING!** Do not work on the drive when the permanent magnet motor is rotating. Also, when the supply power is switched off and the inverter is stopped, a rotating permanent magnet motor feeds power to the intermediate circuit of the drive and the supply connections become live.

Before installation and maintenance work on the drive:

- Stop the motor.
  - Ensure that the motor cannot rotate during work.
  - Ensure that there is no voltage on the drive power terminals:  
*Alternative 1)* Disconnect the motor from the drive with a safety switch or by other means. Measure that there is no voltage present on the drive input or output terminals (U1, V1, W1, U2, V2, W2).  
*Alternative 2)* Measure that there is no voltage present on the drive input or output terminals (U1, V1, W1, U2, V2, W2). Ground the drive output terminals temporarily by connecting them together as well as to the PE.  
*Alternative 3)* If possible, both of the above.
- 

### Start-up and operation

---



**WARNING!** Do not run the motor over the rated speed. Motor overspeed leads to overvoltage which may damage or explode the capacitors in the intermediate circuit of the drive.

Controlling a permanent magnet motor is only allowed using the ACS800 Permanent Magnet Synchronous Motor Drive Application Program, or other application programs in scalar control mode.

---



# Table of contents

---

ACS800 Single Drive Manuals .....	2
-----------------------------------	---

## ***Safety instructions***

What this chapter contains .....	5
To which products this chapter applies .....	5
Use of warnings and notes .....	5
Installation and maintenance work .....	6
Grounding .....	7
Mechanical installation and maintenance .....	8
Printed circuit boards .....	9
Fibre optic cables .....	9
Operation .....	10
Permanent magnet motor .....	11
Installation and maintenance work .....	11
Start-up and operation .....	11

## ***Table of contents***

### ***About this manual***

What this chapter contains .....	19
Target audience .....	19
Common chapters for several products .....	19
Categorization according to the frame size .....	19
Categorization according to the plus code .....	19
Contents .....	20
Other related manuals .....	20
Installation, commissioning and operating flowchart .....	20
Inquiries .....	21

### ***The ACS800-04/U4 and ACS800-04M***

What this chapter contains .....	23
The ACS800-04/U4 .....	23
The ACS800-04M .....	24
Example configurations .....	24
Type designation label .....	25
Type code .....	26
Control interfaces .....	28
Connections of the Drive Control Unit (RDCU) in frame sizes R7 and R8 .....	29
Operation .....	29
Printed circuit boards .....	30
Motor control .....	30

**Mechanical installation**

What this chapter contains	31
Before installation	31
Delivery check	31
Requirements for the installation site	31
Cooling air flow	31
Cable channel in the floor below the cabinet	32
Fastening the cabinet to the floor and wall	32
Electric welding	32

**Planning the electrical installation**

What this chapter contains	33
To which products this chapter applies	33
Motor selection and compatibility	33
Protecting the motor insulation and bearings	34
Requirements table	35
Permanent magnet synchronous motor	37
Supply connection	37
Disconnecting device (disconnecting means)	37
ACS800-01, ACS800-U1, ACS800-11, ACS800-U11, ACS800-02,	
ACS800-U2 without enclosure extension, ACS800-04, ACS800-U4	37
ACS800-U2 with enclosure extension, ACS800-07 and ACS800-U7	37
EU	37
US	37
Fuses	37
Thermal overload and short-circuit protection	38
Mains cable (AC line cable) short-circuit protection	38
ACS800-01/U1, ACS800-11/U11, ACS800-02/U2 without enclosure extension and	
ACS800-04/U4	38
Drive AC fuses (ACS800-07/U7, and ACS800-02/U2 with enclosure extension)	38
Operating time of the fuses	38
Circuit breakers	39
Ground fault protection	39
Emergency stop devices	39
ACS800-02/U2 with enclosure extension and ACS800-07/U7	39
Restarting after an emergency stop	39
Prevention of Unexpected Start	40
Selecting the power cables	41
General rules	41
Alternative power cable types	42
Motor cable shield	42
Additional US requirements	43
Conduit	43
Armored cable / shielded power cable	43
Power factor compensation capacitors	43

Equipment connected to the motor cable .....	44
Installation of safety switches, contactors, connection boxes, etc. ....	44
Bypass connection .....	44
Before opening a contactor (DTC control mode selected) .....	44
Protecting the relay output contacts and attenuating disturbances in case of inductive loads ....	45
Selecting the control cables .....	46
Relay cable .....	46
Control panel cable .....	46
Connection of a motor temperature sensor to the drive I/O .....	47
Routing the cables .....	47
Control cable ducts .....	48

### ***Electrical installation***

What this chapter contains .....	49
Warnings .....	49
Checking the insulation of the assembly .....	49
IT (ungrounded) systems .....	50
Example wiring diagram .....	51
Power cable connection diagram .....	52
Grounding of the cable shields .....	53
Fastening US cable lugs .....	54
Example mounting .....	54
Connections of the RDCU .....	55
Connecting the control cables to the RMIO board .....	56
Connecting the shield wires at RMIO board .....	56
Securing the control cables mechanically .....	56
Settings of the cooling fan transformer .....	57
Installation of optional modules .....	57
Cabling of I/O and fieldbus modules .....	57
Pulse encoder module cabling .....	58
Fibre optic link .....	58
Warning sticker .....	58

### ***Motor control and I/O board (RMIO)***

What this chapter contains .....	59
To which products this chapter applies .....	59
Note for the ACS800-02 with enclosure extension and the ACS800-07 .....	59
Note on external power supply .....	59
External control connections (non-US) .....	60
External control connections (US) .....	61

RMIO board specifications	.62
Analogue inputs	.62
Constant voltage output	.62
Auxiliary power output	.62
Analogue outputs	.62
Digital inputs	.62
Relay outputs	.63
DDCS fibre optic link	.63
24 VDC power input	.63

## **Maintenance**

What this chapter contains	.65
Safety	.65
Maintenance intervals	.66
Layout	.67
Heatsink	.68
Fan	.68
Replacing the fan (R7)	.69
Replacing the fan (R8)	.70
Capacitors	.71
Reforming	.71
Replacing the capacitor pack (R7)	.71
Replacing the capacitor pack (R8)	.72
Replacing the drive module	.73
LEDs	.74

## **Technical data**

What this chapter contains	.75
IEC ratings	.75
Symbols	.76
Sizing	.77
Derating	.77
Temperature derating	.77
Altitude derating	.77
Mains cable fuses	.77
Standard gG fuses	.78
Ultraprapid (aR) fuses	.79
Cable types	.80
Cable entries	.80
Dimensions, weights and noise	.81
Input power connection	.81
Motor connection	.82
Efficiency	.82
Cooling	.82
Degrees of protection	.82
Prevention of Unexpected Start: AGPS-21 board	.82
Ambient conditions	.83
Materials	.84



Applicable standards	84
CE marking	85
Definitions	85
Compliance with the EMC Directive	85
Compliance with the EN 61800-3 + Amendment A11 (2000)	85
First environment (restricted distribution)	85
Second environment	86
Machinery Directive	86
“C-tick” marking	87
Definitions	87
Compliance with IEC 61800-3	87
First environment (restricted distribution)	87
Second environment	88
Equipment warranty and liability	88
US tables	89
NEMA ratings	89
Symbols	90
Input cable fuses	90
Ultrarapid (aR) fuses	92
Cable types	93
Cable Entries	93
Dimensions and weights	94
UL/CSA markings	94
UL	94

### ***Resistor braking***

What this chapter contains	95
To which products this chapter applies	95
Availability of brake choppers and resistors for the ACS800	95
How to select the correct drive/chopper/resistor combination	95
Optional brake chopper and resistor(s) for the ACS800-01/U1	96
Optional brake chopper and resistor(s) for the ACS800-02/U2, ACS800-04/04M/U4 and ACS800-07/U7	98
Resistor installation and wiring	100
ACS800-07/U7	101
Protection of frame sizes R2 to R5 (ACS800-01/U1)	101
Protection of frame size R6 (ACS800-01, ACS800-07) and frame sizes R7 and R8 (ACS800-02, ACS800-04, ACS800-07)	101
Brake circuit commissioning	102



# About this manual

---

## What this chapter contains

This chapter describes the intended audience and contents of the manual. It contains a flowchart of steps in checking the delivery, installing and commissioning the drive. The flowchart refers to chapters/sections in this manual and other manuals.

## Target audience

This manual is intended for people who plan the electrical installation, install, commission, use and service the drive. Read the manual before working on the drive. The reader is expected to know the fundamentals of electricity, wiring, electrical components and electrical schematic symbols.

The manual is written for readers worldwide. Both SI and imperial units are shown. Special US instructions for installations within the United States that must be installed per the National Electrical Code and local codes are marked with (US).

## Common chapters for several products

Chapters *Planning the electrical installation*, *Motor control and I/O board (RMIO)* and *Resistor braking* apply to the ACS800-01/U1, ACS800-02/U2, ACS800-04/04M/U4 and ACS800-07/U7 types up to -0610-x. *Safety instructions* apply to the ACS800-01/U1, ACS800-02/U2 and ACS800-04/04M/U4.

## Categorization according to the frame size

The instructions, technical data and dimensional drawings which concern only certain frame sizes are marked with the symbol of the frame size R2, R3... or R8. The frame size is not marked on the drive designation label. To identify the frame size of your drive, see rating tables in chapter *Technical data*.

## Categorization according to the plus code

The instructions, technical data and dimensional drawings which concern only certain optional selections are marked with plus codes, e.g. +E210 or +H354. The options included in the drive can be identified from the plus codes visible on the type designation label of the drive. The plus code selections are listed in chapter *The ACS800-04/U4 and ACS800-04M* under *Type code*.

## Contents

The chapters of this manual are briefly described below.

*Safety instructions* give safety instructions for the installation, commissioning, operation and maintenance of the drive.

*About this manual* introduces this manual.

*The ACS800-04/U4 and ACS800-04M* describes the drive.

*Mechanical installation* describes the mechanical installation of the drive cabinet generally.

*Planning the electrical installation* instructs on the motor and cable selection, protections and cable routing.

*Electrical installation* instructs how to wire the drive.

*Motor control and I/O board (RMIO)* shows external control connections and specifications of the motor control and I/O board.

*Maintenance* contains preventive maintenance instructions.

*Technical data* contains the technical specifications of the drive, e.g. the ratings, sizes and technical requirements, provisions for fulfilling the requirements for CE and other markings and warranty policy.

*Resistor braking* describes how to select, protect and wire optional brake choppers and resistors. The chapter also contains technical data.

## Other related manuals

Refer to *ACS800-04/04M/U4 Cabinet Installation* [3AFE68360323 (English)] for information concerning the drive module such as

- dimensional drawings of the drive module
- installing the drive module into a cabinet.

## Installation, commissioning and operating flowchart

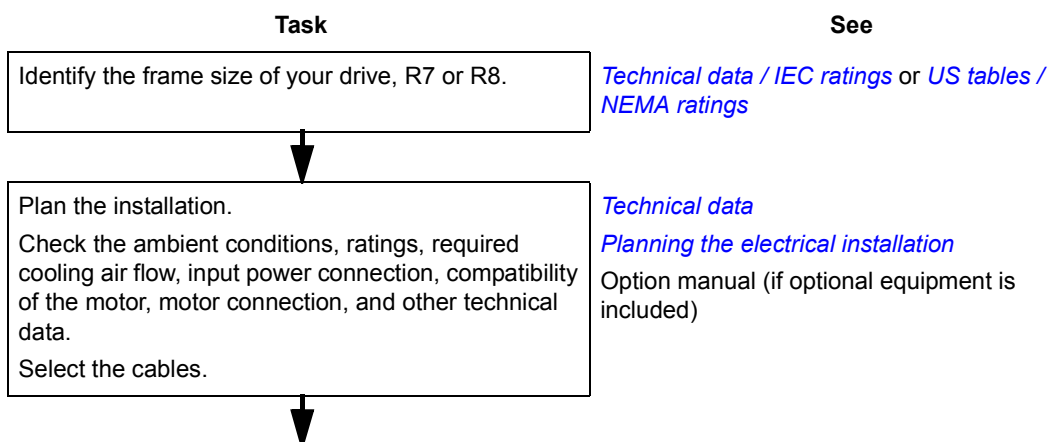

Task	See
Unpack and check the units. Check that all necessary optional modules and equipment are present and correct. Only intact units may be started up.	If the converter has been non-operational for more than one year, the converter DC link capacitors need to be reformed. Ask ABB for instructions.
Check the installation site.	<i>Technical data</i>
If the drive is about to be connected to an IT (ungrounded) system, check that the drive is not equipped with EMC filter +E202.	<i>The ACS800-04/U4 and ACS800-04M: <a href="#">Type code</a>. For instructions on how to disconnect the EMC filtering, contact ABB.</i>
Route the cables.	<i>Planning the electrical installation: <a href="#">Routing the cables</a></i>
Check the insulation of the motor and the motor cable.	<i>Electrical installation: <a href="#">Checking the insulation of the assembly</a></i>
Install the drive. Connect the power cables. Connect the control and the auxiliary control cables.	<i>Electrical installation, <a href="#">Resistor braking</a> (optional)</i>
Commission the drive.	Appropriate firmware manual
Commission the optional brake chopper (if present).	<i><a href="#">Resistor braking</a></i>
Operating of the drive: start, stop, speed control etc.	Appropriate firmware manual

## Inquiries

Address any inquiries about the product to the local ABB representative, quoting the type code and serial number of the unit. If the local ABB representative cannot be contacted, address inquiries to the manufacturing facility.



# The ACS800-04/U4 and ACS800-04M

---

## What this chapter contains

This chapter describes the construction and operating principle of the drive in short.

## The ACS800-04/U4

The ACS800-04/U4 is an IP 00 drive module for controlling AC motors. It is to be installed into a cabinet by the customer with base or wall fastening. The input cable terminals are located at the top of the unit whereas the motor cable terminals are located at the left- or right-hand side of the unit. The unit is delivered pre-assembled with mounting pedestal and output busbars.

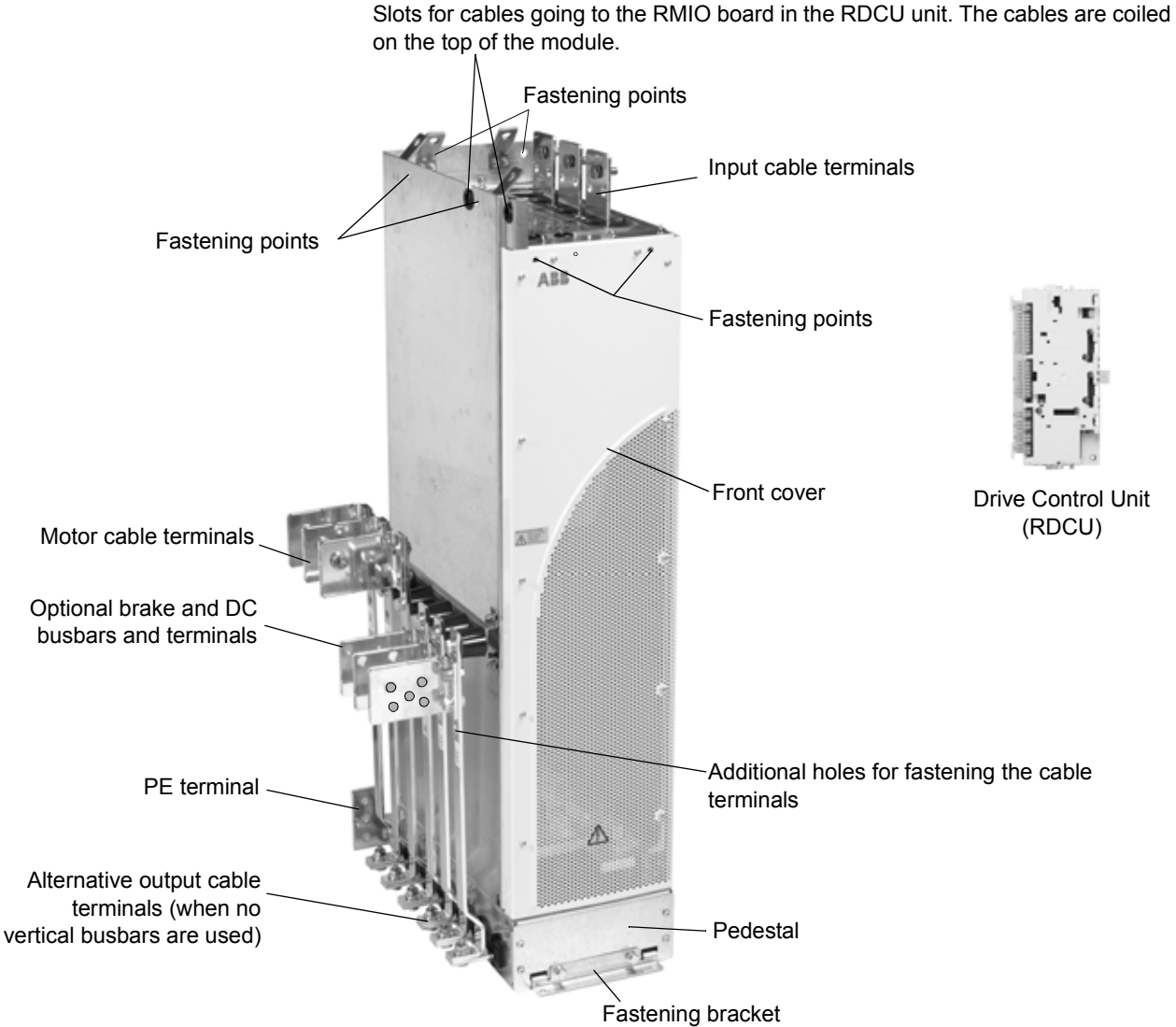

## The ACS800-04M

The ACS800-04M is delivered as non-pre-assembled kits, which provide more alternatives in assembling the units than the basic ACS800-04.

### Example configurations

Frame size R7

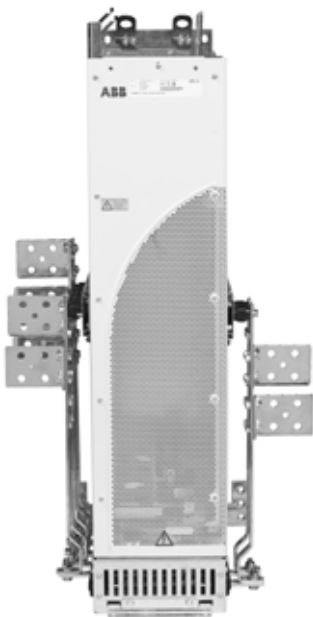

Motor and brake busbars on the left-hand long side of the module and DC busbars on the right-hand side



Motor and brake busbars on the right-hand long side of the module and DC busbars on the left-hand side



Output busbars on the short side of the module

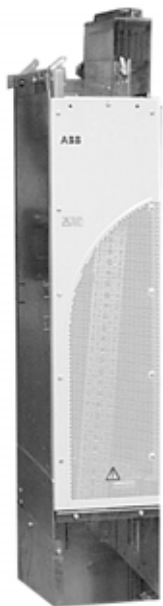

Frame size R7 with bottom exit (optional top entry busbar shroud and bottom exit shroud included). Output busbars are located at the base of the module.



Drive Control Unit (RDCU)

Frame size R8

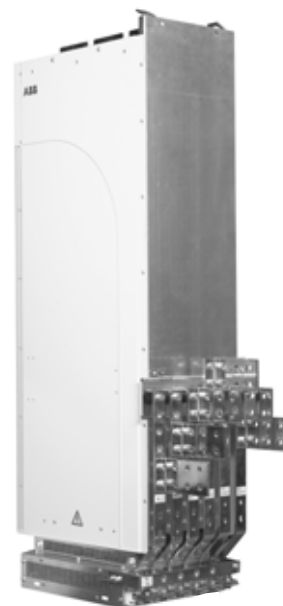

Output busbars on the short side of the module



## Type designation label

The type designation label includes an IEC and NEMA rating, C-UL US, and CSA markings, a type code and a serial number, which allow individual recognition of each unit. The first digit of the serial number refers to the manufacturing plant. The next four digits refer to the unit's manufacturing year and week respectively. The remaining digits complete the serial number so that there are no two units with the same serial number.

The type designation label is located on the front cover and the serial number label inside the unit. Example labels are shown below.

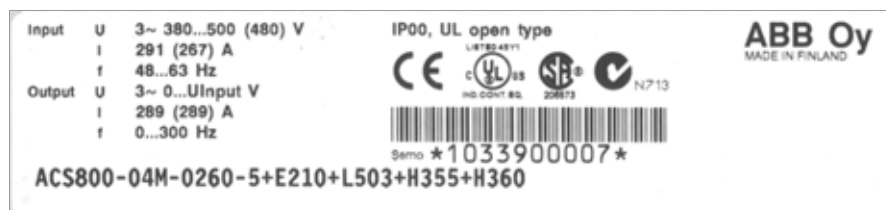

## Type code

The type code contains information on the specifications and configuration of the drive. The first digits from left express the basic configuration (e.g. ACS800-04-0170-5). The optional selections are given thereafter, separated by plus signs (e.g. +E202). The main selections are described below. Not all selections are available for all types. For more information, refer to *ACS800 Ordering Information* (EN code: 64556568, available on request).

Type code for ACS800-04 and ACS800-U4 pre-assembled units		
Selection	Alternatives	
<b>Product series</b>	ACS800 product series	
<b>Type</b>	04	Drive module. When no options are selected: 6-pulse diode input bridge, IP 00, top entry, side exit, RDCU drive control unit, no control panel, no EMC filter, Standard Application Program, boards without coating, pedestal with output on the long side, output busbar set for motor, base and wall mounting brackets, one set of manuals. Pre-assembled unit.
	U4	Drive module (USA). When no options are selected: 6-pulse diode bridge, open chassis, top entry, side exit, no control panel, no EMC filter, US version of the Standard Application Program (three-wire start/stop as default setting), common mode filter in frame size R8, boards without coating, pedestal with output on the long side, output busbar set for motor, base and wall mounting brackets, one set of manuals. Pre-assembled unit.
<b>Size</b>	Refer to <i>Technical data: IEC ratings or NEMA ratings</i> .	
<b>Voltage range (nominal rating in bold)</b>	2	208/220/ <b>230</b> /240 VAC
	3	380/ <b>400</b> /415 VAC
	5	380/400/415/440/460/480/ <b>500</b> VAC
	7	525/575/600/ <b>690</b> VAC
+ options		
<b>Resistor braking</b>	D150	brake chopper and busbars for brake resistor and DC connection
<b>Filter</b>	E210	EMC/RFI filter for second environment TN/IT (grounded/ungrounded) system
	E208	common mode filter
<b>Pedestal and output busbars</b>	0H354	no pedestal
<b>Control panel</b>	J400	control panel including a 3-metre panel connection cable
	J410	RPMP-11/13 control panel mounting platform kit including a 3-metre panel connection cable but no control panel
	J413	RPMP-21 control panel holder
<b>Fieldbus</b>	K...	Refer to <i>ACS800 Ordering Information</i> (EN code: 64556568).
<b>I/O</b>	L...	
<b>Application program</b>	N...	
<b>Language of manual</b>	R...	
<b>Specialities</b>	P901	coated boards

Type code for ACS800-04M non-pre-assembled units (delivered as kits)		
Selection	Alternatives	
Product series	ACS800 product series	
Type	04M	Drive module. When no options are selected: 6-pulse diode input bridge, IP 00, top entry, RDCU drive control unit, Standard Application Program, boards without coating, one set of manuals. No pedestal, no output busbars, no control panel, no EMC filter. Delivered as kits.
Size	Refer to <i>Technical data: IEC ratings</i> .	
Voltage range (nominal rating in bold)	2	208/220/ <b>230</b> /240 VAC
	3	380/ <b>400</b> /415 VAC
	5	380/400/415/440/460/480/ <b>500</b> VAC
	7	525/575/600/ <b>690</b> VAC
+ options		
Shrouds	B060	<u>Frame size R7</u> : clear plastic shrouds for bottom exit kit (+H352) and input terminals. <u>Frame size R8</u> : clear plastic shrouds for vertical busbars and input terminals in bookshelf mounting (+H354)
Resistor braking	D150	brake chopper
Filter	E202	EMC/RFI filter for first environment TN (grounded) system, restricted (the A limits)
	E210	EMC/RFI filter for second environment TN/IT (grounded/ungrounded) system
	E208	common mode filter
Pedestal and output busbars	H352	bottom exit kit for frame size R7
	H354	pedestal with output on the long side (bookshelf)
	H355	vertical busbars and support brackets for AC output connection
	H356	pedestal (and adapter with +H360) busbar kit for brake resistor and DC connection
	H360	pedestal with output on the short side (flat)
	H362	vertical busbars (and support brackets with +H360) for DC output connection
	H363	busbar kit for DC connection on both long sides of the pedestal (+H356 required, not available for +H360)
Control panel	J400	control panel including a 3-metre panel connection cable
	J410	RPMP-11/13 control panel mounting platform kit including a 3-metre panel connection cable but no control panel
	J413	RPMP-21 control panel holder
Fieldbus	K...	Refer to <i>ACS800 Ordering Information</i> (EN code: 64556568).
I/O	L...	
Application program	N...	
Language of manual	R...	
Specialities	P901	coated boards
Safety features	Q950	Prevention of Unexpected Start, 500 mm (19.68 in.) cable outside the drive module in frame size R7, 600 mm (23.62 in.) cable outside the drive module in frame size R8.

## Control interfaces

This diagram shows the control interfaces and the main circuit of the drive.

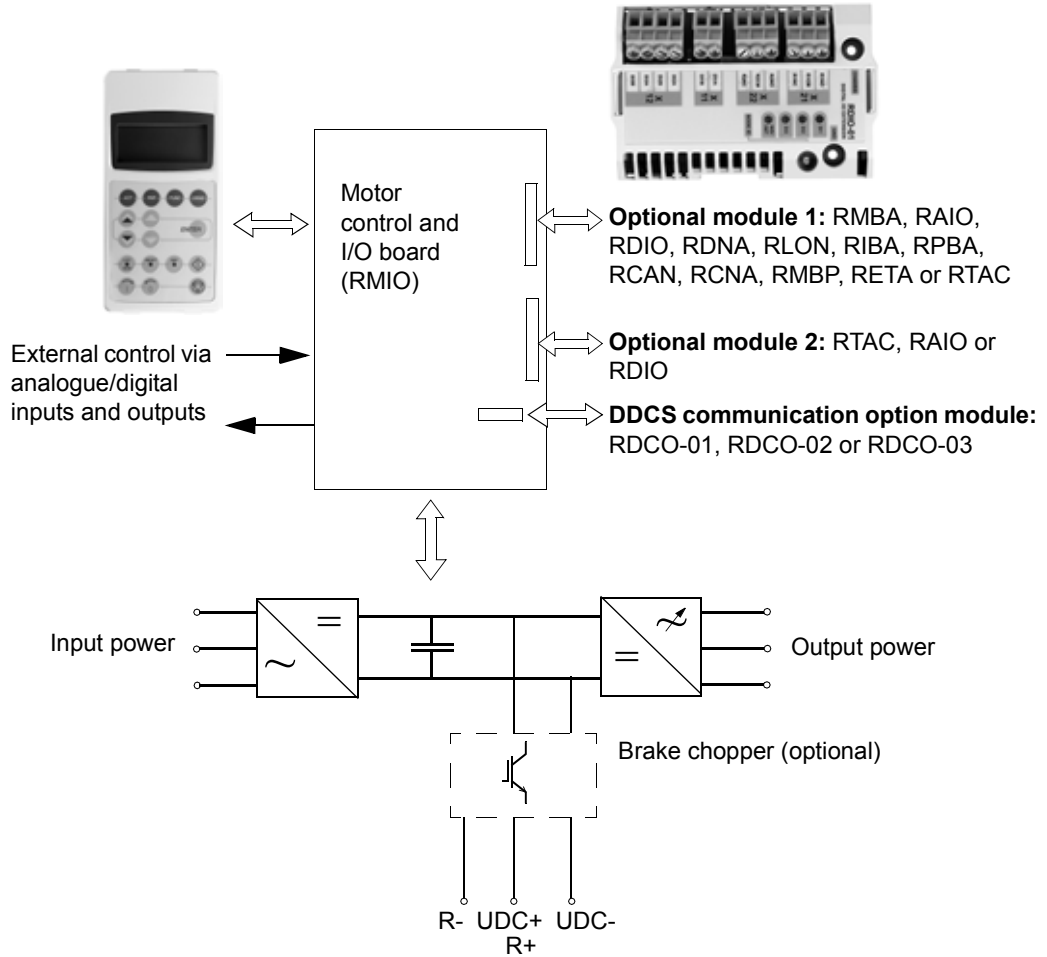

## Connections of the Drive Control Unit (RDCU) in frame sizes R7 and R8

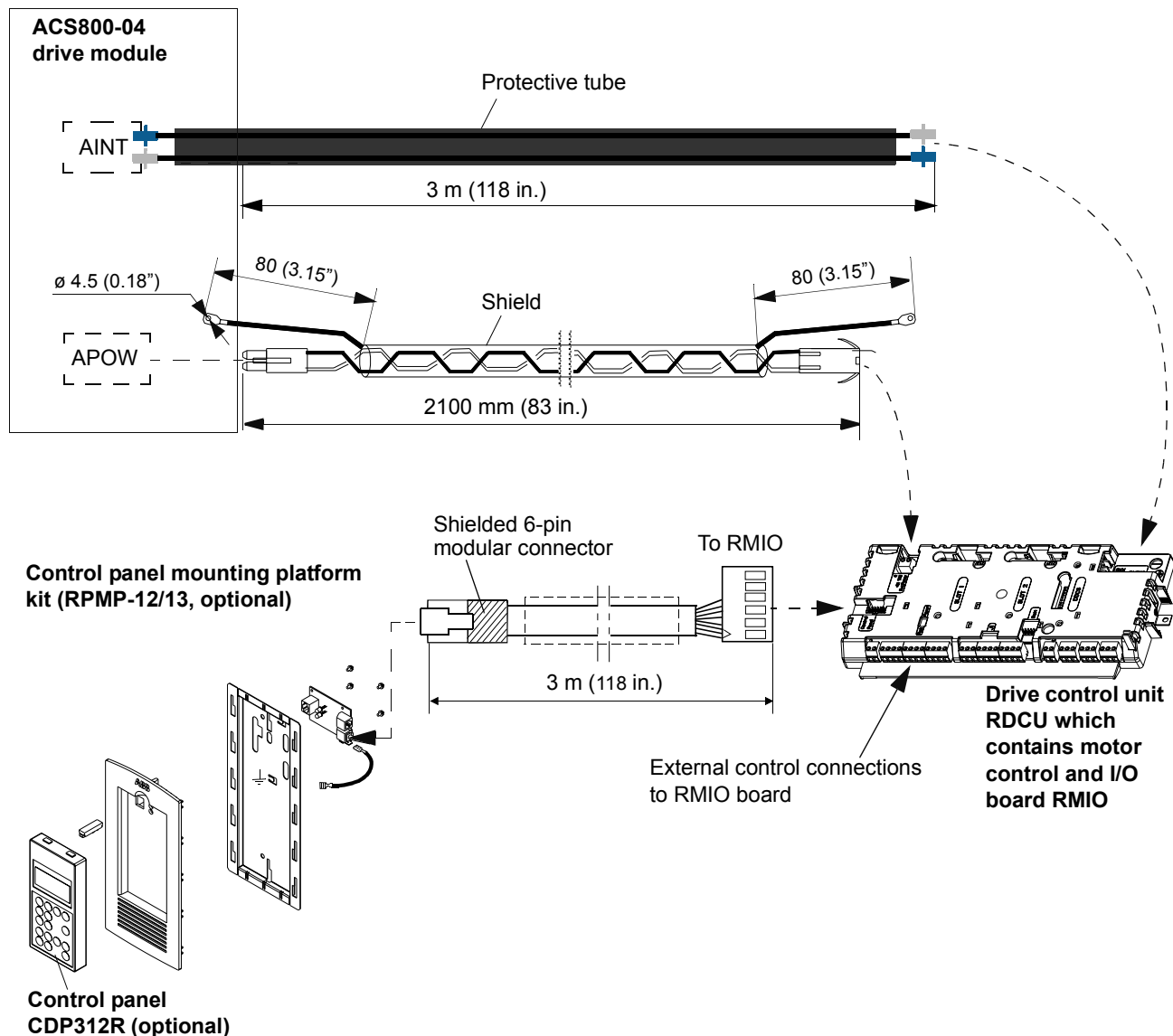

## Operation

This table describes the operation of the main circuit in short.

Component	Description
six-pulse rectifier	converts the three-phase AC voltage to DC voltage
capacitor bank	energy storage which stabilizes the intermediate circuit DC voltage
six-pulse IGBT inverter	converts the DC voltage to AC voltage and vice versa. The motor operation is controlled by switching the IGBTs.

**Printed circuit boards**

The drive contains the following printed circuit boards as standard:

- main circuit board (AINT)
- motor control and I/O board (RMIO) with a fibre optic link to the AINT board
- input bridge control board (AINP)
- input bridge protection board (AIBP) which includes snubbers for the thyristors and varistors
- power supply board (APOW)
- gate driver control board (AGDR)
- diagnostics and panel interface board (ADPI)
- brake chopper control board (ABRC) with option +D150

**Motor control**

The motor control is based on the Direct Torque Control (DTC) method. Two phase currents and DC link voltage are measured and used for the control. The third phase current is measured for earth fault protection.

# Mechanical installation

---

## What this chapter contains

This chapter describes the mechanical installation of the drive cabinet generally. Follow the specific instructions given by the panel builder. For the mechanical assembly and dimensional drawings of the drive module, refer to *ACS800-04/04M/U4 Cabinet Installation* [3AFE68360323 (English)].

## Before installation

### Delivery check

The drive delivery contains:

- drive cabinet including factory installed options such as optional modules (inserted onto the RMIO board in the RDCU unit)
- residual voltage warning stickers
- hardware manual
- appropriate firmware manuals and guides
- appropriate optional module manuals
- delivery documents.

### Requirements for the installation site

Check the installation site according to the requirements below. See [Technical data](#) for the allowed operation conditions of the drive.

### Cooling air flow

Provide the drive with the amount of clean cooling air given in [Technical data / IEC ratings](#) or [US tables](#).

### Cable channel in the floor below the cabinet

When a cable channel is constructed below the cabinet, ensure that cabinet weight lies on the sections which the floor carries.

*Example cabinet frame viewed from above*

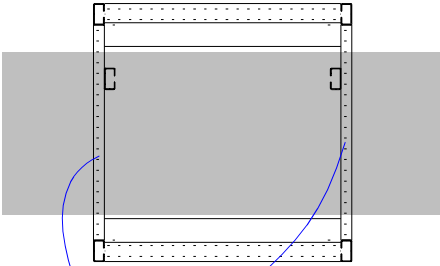

With heavy cabinets, support the structural C-sections from below.

*Example cabinet: side view*

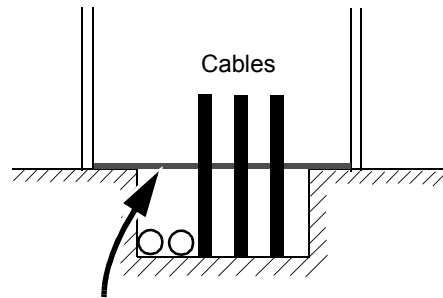

Prevent the cooling air flow from the cable channel to the cabinet by bottom plates. To ensure the degree of protection for the cabinet use the original bottom plates delivered with the unit. With user-defined cable entries take care of the degree of protection, fire protection and EMC compliance.

### Fastening the cabinet to the floor and wall

Fasten the cabinet to the floor and wall/roof according to the panel builder's instructions, e.g. with outside fastening brackets or by fastening holes inside the cabinet.

### Electric welding

It is not recommended to fasten the cabinet by welding.

If the preferred fastening methods (clamping or bolting through the holes inside the cabinet) cannot be used, proceed as follows:

- Connect the return conductor of the welding equipment to the cabinet frame at the bottom within 0.5 metres of the welding point.



**WARNING!** If the welding return wire is connected improperly, the welding circuit may damage electronic circuits in the cabinet. Ensure that the welding fumes are not inhaled.



# Planning the electrical installation

---

## What this chapter contains

This chapter contains the instructions that you must follow when selecting the motor, cables, protections, cable routing and way of operation for the drive system.

---

**Note:** The installation must always be designed and made according to applicable local laws and regulations. ABB does not assume any liability whatsoever for any installation which breaches the local laws and/or other regulations. Furthermore, if the recommendations given by ABB are not followed, the drive may experience problems that the warranty does not cover.

---

## To which products this chapter applies

This chapter applies to the ACS800-01/U1, ACS800-11/U11, ACS800-02/U2, ACS800-04/U4 and ACS800-07/U7 types up to -0610-x.

## Motor selection and compatibility

1. Select the motor according to the rating tables in chapter *Technical Data*. Use the DriveSize PC tool if the default load cycles are not applicable.
2. Check that the motor ratings lie within the allowed ranges of the drive control program:
  - motor nominal voltage is  $1/2 \dots 2 \cdot U_N$  of the drive
  - motor nominal current is  $1/6 \dots 2 \cdot I_{2hd}$  of the drive in DTC control and  $0 \dots 2 \cdot I_{2hd}$  in scalar control. The control mode is selected by a drive parameter.
3. Check that the motor voltage rating meets the application requirements:
  - The motor voltage is selected according to the AC voltage feeding the drive when the drive is equipped with a diode input bridge (a non-regenerative drive) and will operate in motor mode (i.e. no braking).
  - The motor nominal voltage is selected according to “the equivalent AC power source voltage of the drive” if the intermediate DC circuit voltage of the drive is increased from the nominal level by resistor braking or by the control program of a regenerative IGBT line-side converter (parameter selectable function).

The equivalent AC power source voltage for the drive is calculated as follows:

$$U_{ACeq} = U_{DCmax}/1.35$$

where

$U_{ACeq}$  = equivalent AC power source voltage of the drive

$U_{DCmax}$  = maximum intermediate DC circuit voltage of the drive

See notes 6 and 7 below the [Requirements table](#).

4. Consult the motor manufacturer before using a motor in a drive system where the motor nominal voltage differs from the AC power source voltage.
5. Ensure that the motor insulation system withstands the maximum peak voltage in the motor terminals. See the [Requirements table](#) below for the required motor insulation system and drive filtering.

**Example:** When the supply voltage is 440 V and the drive is operating in motor mode only, the maximum peak voltage in the motor terminals can be approximated as follows:  $440 \text{ V} \cdot 1.35 \cdot 2 = 1190 \text{ V}$ . Check that the motor insulation system withstands this voltage.

### Protecting the motor insulation and bearings

The output of the drive comprises – regardless of output frequency – pulses of approximately 1.35 times the equivalent mains network voltage with a very short rise time. This is the case with all drives employing modern IGBT inverter technology.

The voltage of the pulses can be almost double at the motor terminals, depending on the attenuation and reflection properties of the motor cable and the terminals. This in turn can cause additional stress on the motor and motor cable insulation.

Modern variable speed drives with their fast rising voltage pulses and high switching frequencies can generate current pulses that flow through the motor bearings, which can gradually erode the bearing races and rolling elements.

The stress on motor insulation can be avoided by using optional ABB du/dt filters. du/dt filters also reduce bearing currents.

To avoid damage to motor bearings, the cables must be selected and installed according to the instructions given in the hardware manual. In addition, insulated N-end (non-driven end) bearings and output filters from ABB must be used according to the following table. Two types of filters are used individually or in combinations:

- optional du/dt filter (protects motor insulation system and reduces bearing currents).
- common mode filter (mainly reduces bearing currents).

## Requirements table

The following table shows how to select the motor insulation system and when an optional ABB du/dt filter, insulated N-end (non-driven end) motor bearings and ABB common mode filters are required. The motor manufacturer should be consulted regarding the construction of the motor insulation and additional requirements for explosion-safe (EX) motors. Failure of the motor to fulfil the following requirements or improper installation may shorten motor life or damage the motor bearings.

Manufacturer	Motor type	Nominal mains voltage (AC line voltage)	Requirement for			
			Motor insulation system	ABB du/dt filter, insulated N-end bearing and ABB common mode filter		
				$P_N < 100 \text{ kW}$ and frame size < IEC 315	$100 \text{ kW} \leq P_N < 350 \text{ kW}$ or frame size $\geq$ IEC 315	$P_N \geq 350 \text{ kW}$ or frame size $\geq$ IEC 400
				$P_N < 134 \text{ HP}$ and frame size < NEMA 500	$134 \text{ HP} \leq P_N < 469 \text{ HP}$ or frame size $\geq$ NEMA 500	$P_N \geq 469 \text{ HP}$ or frame size > NEMA 580
A B B	Random-wound M2_ and M3_	$U_N \leq 500 \text{ V}$	Standard	-	+ N	+ N + CMF
		$500 \text{ V} < U_N \leq 600 \text{ V}$	Standard	+ du/dt	+ du/dt + N	+ du/dt + N + CMF
			or			
		Reinforced	-	+ N	+ N + CMF	
	$600 \text{ V} < U_N \leq 690 \text{ V}$	Reinforced	+ du/dt	+ du/dt + N	+ du/dt + N + CMF	
	Form-wound HX_ and AM_	$380 \text{ V} < U_N \leq 690 \text{ V}$	Standard	n.a.	+ N + CMF	$P_N < 500 \text{ kW}$ : + N + CMF $P_N \geq 500 \text{ kW}$ : + N + CMF + du/dt
Old* form-wound HX_ and modular	$380 \text{ V} < U_N \leq 690 \text{ V}$	Check with the motor manufacturer.	+ du/dt with voltages over 500 V + N + CMF			
Random-wound HX_ and AM_ **	$0 \text{ V} < U_N \leq 500 \text{ V}$	Enamelled wire with fibre glass taping	+ N + CMF			
	$500 \text{ V} < U_N \leq 690 \text{ V}$		+ du/dt + N + CMF			
N O N - A B B	Random-wound and form-wound	$U_N \leq 420 \text{ V}$	Standard: $\hat{U}_{LL} = 1300 \text{ V}$	-	+ N or CMF	+ N + CMF
		$420 \text{ V} < U_N \leq 500 \text{ V}$	Standard: $\hat{U}_{LL} = 1300 \text{ V}$	+ du/dt	+ du/dt + N	+ du/dt + N + CMF
				or	+ du/dt + CMF	
				or		
		$500 \text{ V} < U_N \leq 600 \text{ V}$	Reinforced: $\hat{U}_{LL} = 1600 \text{ V}$	-	+ N or CMF	+ N + CMF
				+ du/dt	+ du/dt + N	+ du/dt + N + CMF
		or				
		$600 \text{ V} < U_N \leq 690 \text{ V}$	Reinforced: $\hat{U}_{LL} = 1800 \text{ V}$	-	+ N or CMF	+ N + CMF
				+ du/dt	+ du/dt + N	+ du/dt + N + CMF
			Reinforced: $\hat{U}_{LL} = 2000 \text{ V}$ , 0.3 microsecond rise time ***	-	N + CMF	N + CMF

- \* manufactured before 1.1.1998
- \*\* For motors manufactured before 1.1.1998, check for additional instructions with the motor manufacturer.
- \*\*\* If the intermediate DC circuit voltage of the drive will be increased from the nominal level by resistor braking or by the IGBT supply unit control program (parameter selectable function), check with the motor manufacturer if additional output filters are needed in the applied drive operation range.

**Note 1:** The abbreviations used in the table are defined below.

Abbreviation	Definition
$U_N$	nominal voltage of the supply network
$\hat{U}_{LL}$	peak line-to-line voltage at motor terminals which the motor insulation must withstand
$P_N$	motor nominal power
du/dt	du/dt filter at the output of the drive +E205
CMF	common mode filter +E208
N	N-end bearing: insulated motor non-driven end bearing
n.a.	Motors of this power range are not available as standard units. Consult the motor manufacturer.

**Note 2:** *Explosion-safe (EX) motors*

The motor manufacturer should be consulted regarding the construction of the motor insulation and additional requirements for explosion-safe (EX) motors.

**Note 3:** *High-output motors and IP 23 motors*

For motors with higher rated output than what is stated for the particular frame size in EN 50347 (2001) and for IP 23 motors, the requirements of ABB random-wound motor series M3AA, M3AP, M3BP are given below. For other motor types, see the [Requirements table](#) above. Apply the requirements of range  $100\text{ kW} < P_N < 350\text{ kW}$  to motors with  $P_N < 100\text{ kW}$ . Apply the requirements of range  $P_N \geq 350\text{ kW}$  to motors within the range  $100\text{ kW} < P_N < 350\text{ kW}$ . In other cases, consult the motor manufacturer.

Manufacturer	Motor type	Nominal mains voltage (AC line voltage)	Requirement for			
			Motor insulation system	ABB du/dt filter, insulated N-end bearing and ABB common mode filter		
				$P_N < 55\text{ kW}$	$55\text{ kW} \leq P_N < 200\text{ kW}$	$P_N \geq 200\text{ kW}$
			$P_N < 74\text{ HP}$	$74\text{ HP} \leq P_N < 268\text{ HP}$	$P_N \geq 268\text{ HP}$	
A B B	Random-wound M3AA, M3AP, M3BP	$U_N \leq 500\text{ V}$	Standard	-	+ N	+ N + CMF
		$500\text{ V} < U_N \leq 600\text{ V}$	Standard	+ du/dt	+ du/dt + N	+ du/dt + N + CMF
			or	Reinforced	-	+ N
		$600\text{ V} < U_N \leq 690\text{ V}$	Reinforced	+ du/dt	+ du/dt + N	+ du/dt + N + CMF

**Note 4:** *HXR and AMA motors*

All AMA machines (manufactured in Helsinki) for drive systems have form-wound windings. All HXR machines manufactured in Helsinki starting 1.1.1998 have form-wound windings.

**Note 5:** *ABB motors of types other than M2\_, M3\_, HX\_ and AM\_*

Use the selection criteria given for non-ABB motors.

**Note 6:** *Resistor braking of the drive*

When the drive is in braking mode for a large part of its operation time, the intermediate circuit DC voltage of the drive increases, the effect being similar to increasing the supply voltage by up to 20 percent. The voltage increase should be taken into consideration when determining the motor insulation requirement.

Example: Motor insulation requirement for a 400 V application must be selected as if the drive were supplied with 480 V.

**Note 7: Drives with an IGBT supply unit**

If voltage is raised by the drive (this is a parameter selectable function), select the motor insulation system according to the increased intermediate circuit DC voltage level, especially in the 500 V supply voltage range.

**Permanent magnet synchronous motor**

Only one permanent magnet motor can be connected to the inverter output.

It is recommended to install a safety switch between the permanent magnet synchronous motor and the drive output. The switch is needed to isolate the motor during any maintenance work on the drive.

**Supply connection****Disconnecting device (disconnecting means)**

*ACS800-01, ACS800-U1, ACS800-11, ACS800-U11, ACS800-02, ACS800-U2 without enclosure extension, ACS800-04, ACS800-U4*

Install a hand-operated input disconnecting device (disconnecting means) between the AC power source and the drive. The disconnecting device must be of a type that can be locked to the open position for installation and maintenance work.

*ACS800-U2 with enclosure extension, ACS800-07 and ACS800-U7*

These units are equipped with a hand-operated input disconnecting device (disconnecting means) which isolates the drive and the motor from the AC power as standard. The disconnecting device does not, however, isolate the input busbars from the AC power. Therefore during installation and maintenance work on the drive, the input cables and busbars must be isolated from the input power with a disconnecter at the distribution board or at the supplying transformer.

**EU**

To meet the European Union Directives, according to standard EN 60204-1, Safety of Machinery, the disconnecting device must be one of the following types:

- switch-disconnector of utilization category AC-23B (EN 60947-3)
- disconnector that has an auxiliary contact that in all cases causes switching devices to break the load circuit before the opening of the main contacts of the disconnector (EN 60947-3)
- circuit breaker suitable for isolation in accordance with EN 60947-2.

**US**

The disconnecting means must conform to the applicable safety regulations.

**Fuses**

See section [Thermal overload and short-circuit protection](#).

## Thermal overload and short-circuit protection

The drive protects itself and the input and motor cables against thermal overload when the cables are dimensioned according to the nominal current of the drive. No additional thermal protection devices are needed.



**WARNING!** If the drive is connected to multiple motors, a separate thermal overload switch or a circuit breaker must be used for protecting each cable and motor. These devices may require a separate fuse to cut off the short-circuit current.

The drive protects the motor cable and motor in a short-circuit situation when the motor cable is dimensioned according to the nominal current of the drive.

### Mains cable (AC line cable) short-circuit protection

Always protect the input cable with fuses. Size the fuses according to local safety regulations, appropriate input voltage and the rated current of the drive (see *Technical Data*).

*ACS800-01/U1, ACS800-11/U11, ACS800-02/U2 without enclosure extension and ACS800-04/U4*

When placed at the distribution board, standard gG (US: CC or T for the ACS800-U1; T or L for the ACS800-U2 and ACS800-U4) fuses will protect the input cable in short-circuit situations, restrict drive damage and prevent damage to adjoining equipment in case of a short-circuit inside the drive.

### Drive AC fuses (ACS800-07/U7, and ACS800-02/U2 with enclosure extension)

ACS800-07/U7 units and ACS800-02/U2 units with enclosure extension are equipped with standard gG (US: T/L) or optional aR fuses listed in *Technical Data*. The fuses restrict drive damage and prevent damage to adjoining equipment in case of a short-circuit inside the drive.

### Operating time of the fuses

**Check that the operating time of the fuse is below 0.5 seconds.** The operating time depends on the fuse type (gG or aR), supply network impedance and the cross-sectional area, material and length of the supply cable. In case the 0.5 seconds operating time is exceeded with gG (US: CC/T/L) fuses, ultrarapid (aR) fuses will in most cases reduce the operating time to an acceptable level. The US fuses must be of the “non-time delay” type.

For fuse ratings, see *Technical Data*.

## Circuit breakers

Circuit breakers which have been tested by ABB with the ACS800 can be used. Fuses must be used with other circuit breakers. Contact your local ABB representative for approved breaker types and supply network characteristics.

The protective characteristics of circuit breakers depend on the type, construction and settings of the breakers. There are also limitations pertaining to the short-circuit capacity of the supply network.



**WARNING!** Due to the inherent operating principle and construction of circuit breakers, independent of the manufacturer, hot ionized gases may escape from the breaker enclosure in case of a short-circuit. To ensure safe use, special attention must be paid to the installation and placement of the breakers. Follow the manufacturer's instructions.

**Note:** Circuit breakers without fuses are not recommended in the USA.

## Ground fault protection

The drive is equipped with an internal ground fault protective function to protect the unit against ground faults in the motor and motor cable. This is not a personal safety or a fire protection feature. The ground fault protective function can be disabled with a parameter, refer to the appropriate *ACS800 Firmware Manual*.

The EMC filter of the drive includes capacitors connected between the main circuit and the frame. These capacitors and long motor cables increase the ground leakage current and may cause fault current circuit breakers to function.

## Emergency stop devices

For safety reasons, install the emergency stop devices at each operator control station and at other operating stations where emergency stop may be needed.

**Note:** Pressing the stop key (⏹) on the control panel of the drive does not generate an emergency stop of the motor or separate the drive from dangerous potential.

### ACS800-02/U2 with enclosure extension and ACS800-07/U7

An emergency stop function is optionally available for stopping and switching off the whole drive. Two stop categories according to IEC/EN 60204-1 (1997) are available: immediate removal of power (Category 0 for ACS800-02/U2 and ACS800-07/U7) and controlled emergency stop (Category 1 for ACS800-07/U7).

#### *Restarting after an emergency stop*

After an emergency stop, the emergency stop button must be released and the drive started by turning the operating switch of the drive from position "ON" to "START".

## Prevention of Unexpected Start

The drive can be equipped with an optional Prevention of Unexpected Start function according to standards IEC/EN 60204-1: 1997; ISO/DIS 14118: 2000 and EN 1037: 1996.

The Prevention of Unexpected Start function disables the control voltage of the power semiconductors, thus preventing the inverter from generating the AC voltage required to rotate the motor. By using this function, short-time operations (like cleaning) and/or maintenance work on non-electrical parts of the machinery can be performed without switching off the AC power supply to the drive.

The operator activates the Prevention of Unexpected Start function by opening a switch on a control desk. An indicating lamp on the control desk will light, signalling that the prevention is active. The switch can be locked out.

The user must install on a control desk near the machinery:

- switching/disconnecting device for the circuitry. "Means shall be provided to prevent inadvertent, and/or mistaken closure of the disconnecting device." EN 60204-1: 1997.
- indicating lamp; on = starting the drive is prevented, off = drive is operative.

For connections to the drive, see the circuit diagram delivered with the drive.



**WARNING!** The Prevention of Unexpected Start function does not disconnect the voltage of the main and auxiliary circuits from the drive. Therefore maintenance work on electrical parts of the drive or the motor can only be carried out after isolating the drive system from the main supply.

---

**Note:** When a running drive is stopped by using the Prevention of Unexpected Start function, the drive will stop by coasting. If this is not acceptable (e.g. causes danger), the drive and machinery must be stopped using the appropriate stopping mode before using this function.



## Selecting the power cables

### General rules

Dimension the mains (input power) and motor cables **according to local regulations**:

- The cable must be able to carry the drive load current. See chapter *Technical data* for the rated currents.
- The cable must be rated for at least 70 °C maximum permissible temperature of conductor in continuous use. For US, see [Additional US requirements](#).
- The inductance and impedance of the PE conductor/cable (grounding wire) must be rated according to permissible touch voltage appearing under fault conditions (so that the fault point voltage will not rise excessively when a ground fault occurs).
- 600 VAC cable is accepted for up to 500 VAC. 750 VAC cable is accepted for up to 600 VAC. For 690 VAC rated equipment, the rated voltage between the conductors of the cable should be minimum 1 kV.

For drive frame size R5 and larger, or motors larger than 30 kW (40 HP), symmetrical shielded motor cable must be used (figure below). A four-conductor system can be used up to frame size R4 with up to 30 kW (40 HP) motors, but shielded symmetrical motor cable is recommended.

A four-conductor system is allowed for input cabling, but shielded symmetrical cable is recommended. To operate as a protective conductor, the shield conductivity must be as follows when the protective conductor is made of the same metal as the phase conductors:

Cross-sectional area of the phase conductors <b>S (mm<sup>2</sup>)</b>	Minimum cross-sectional area of the corresponding protective conductor <b>S<sub>p</sub> (mm<sup>2</sup>)</b>
$S \leq 16$	S
$16 < S \leq 36$	16
$35 < S$	S/2

Compared to a four-conductor system, the use of symmetrical shielded cable reduces electromagnetic emission of the whole drive system as well as motor bearing currents and wear.

The motor cable and its PE pigtail (twisted shield) should be kept as short as possible in order to reduce electromagnetic emission.

### Alternative power cable types

Power cable types that can be used with the drive are represented below.

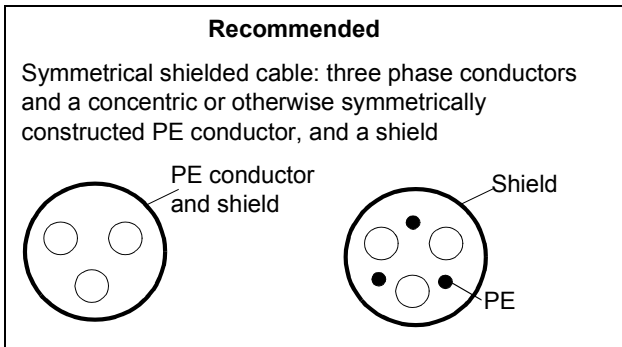

A separate PE conductor is required if the conductivity of the cable shield is < 50 % of the conductivity of the phase conductor.

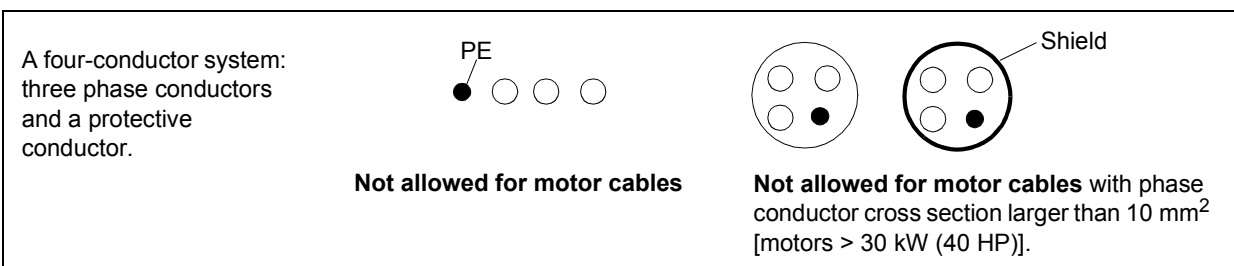
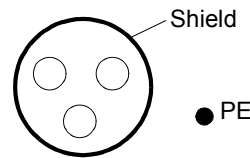

### Motor cable shield

To effectively suppress radiated and conducted radio-frequency emissions, the shield conductivity must be at least 1/10 of the phase conductor conductivity. The requirements are easily met with a copper or aluminium shield. The minimum requirement of the motor cable shield of the drive is shown below. It consists of a concentric layer of copper wires with an open helix of copper tape. The better and tighter the shield, the lower the emission level and bearing currents.

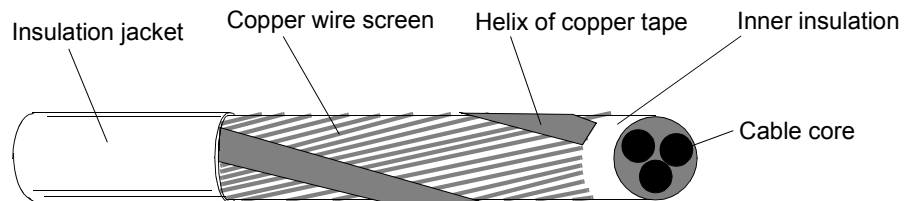

### **Additional US requirements**

Type MC continuous corrugated aluminum armor cable with symmetrical grounds or shielded power cable must be used for the motor cables if metallic conduit is not used. For the North American market, 600 VAC cable is accepted for up to 500 VAC. 1000 VAC cable is required above 500 VAC (below 600 VAC). For drives rated over 100 amperes, the power cables must be rated for 75 °C (167 °F).

#### *Conduit*

Where conduits must be coupled together, bridge the joint with a ground conductor bonded to the conduit on each side of the joint. Bond the conduits also to the drive enclosure. Use separate conduits for input power, motor, brake resistors, and control wiring. Do not run motor wiring from more than one drive in the same conduit.

#### *Armored cable / shielded power cable*

The motor cables can be run in the same cable tray as other 460 V or 600 V power wiring. Control and signal cables must not be run in the same tray as power cables. Six conductor (3 phases and 3 ground) type MC continuous corrugated aluminum armor cable with symmetrical grounds is available from the following suppliers (trade names in parentheses):

- Anixter Wire & Cable (Philsheath)
- BICC General Corp (Philsheath)
- Rockbestos Co. (Gardex)
- Oaknite (CLX).

Shielded power cables are available from Belden, LAPPKABEL (ÖLFLEX) and Pirelli.

### **Power factor compensation capacitors**

Do not connect power factor compensation capacitors or surge absorbers to the motor cables between the drive and the motor. They are not designed to be used with drives, and will degrade motor control accuracy. They can cause permanent damage to the drive or themselves due to the rapid changes in the drive output voltage.

If there are power factor compensation capacitors in parallel with the three phase input of the drive, ensure that the capacitors and the drive are not charged simultaneously to avoid voltage surges which might damage the drive system.

## Equipment connected to the motor cable

### Installation of safety switches, contactors, connection boxes, etc.

To minimize the emission level when safety switches, contactors, connection boxes or similar equipment are installed in the motor cable between the drive and the motor:

- EU: Install the equipment in a metal enclosure with 360 degrees grounding for the shields of both the incoming and outgoing cable, or connect the shields of the cables otherwise together.
- US: Install the equipment in a metal enclosure in a way that the conduit or motor cable shielding runs consistently without breaks from the drive to the motor.

### *Bypass connection*



**WARNING!** Never connect the supply power to the drive output terminals U2, V2 and W2. If frequent bypassing is required, employ mechanically connected switches or contactors. Mains (line) voltage applied to the output can result in permanent damage to the unit.

---

### **Before opening a contactor (DTC control mode selected)**

Stop the drive and wait for the motor to stop before opening a contactor between the output of the drive and the motor when the DTC control mode is selected. See the appropriate ACS800 application program firmware manual for the required parameter settings. Otherwise, the contactor will be damaged. In scalar control, the contactor can be opened with the drive running.

## Protecting the relay output contacts and attenuating disturbances in case of inductive loads

Inductive loads (relays, contactors, motors) cause voltage transients when switched off.

The relay contacts on the RMIO board are protected with varistors (250 V) against overvoltage peaks. In spite of this, it is highly recommended to equip inductive loads with noise attenuating circuits [varistors, RC filters (AC) or diodes (DC)] in order to minimize the EMC emission at switch-off. If not suppressed, the disturbances may connect capacitively or inductively to other conductors in the control cable and form a risk of malfunction in other parts of the system.

Install the protective component as close to the inductive load as possible. Do not install protective components at the RMIO board terminal block.

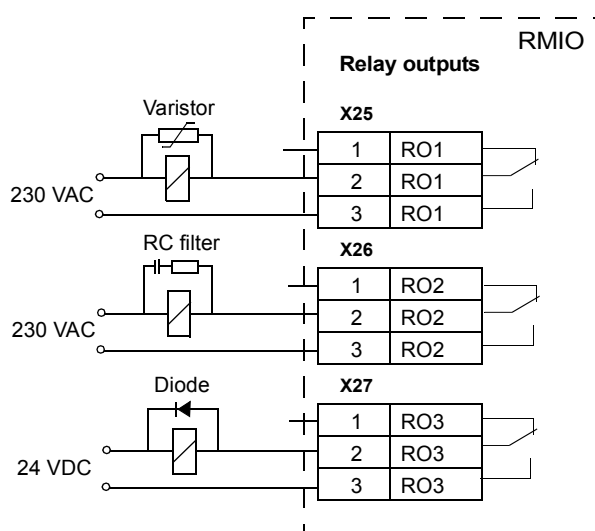

## Selecting the control cables

All control cables must be shielded.

Use a double-shielded twisted pair cable (Figure a, e.g. JAMAK by NK Cables, Finland) for analogue signals. This type of cable is recommended for the pulse encoder signals also. Employ one individually shielded pair for each signal. Do not use common return for different analogue signals.

A double-shielded cable is the best alternative for low-voltage digital signals but single-shielded twisted pair cable (Figure b) is also usable.

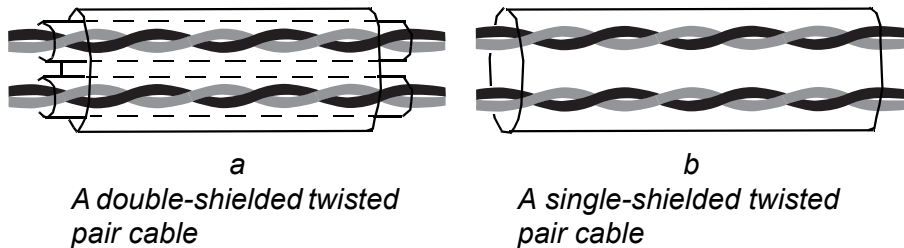

Run analogue and digital signals in separate, shielded cables.

Relay-controlled signals, providing their voltage does not exceed 48 V, can be run in the same cables as digital input signals. It is recommended that the relay-controlled signals be run as twisted pairs.

Never mix 24 VDC and 115/230 VAC signals in the same cable.

### Relay cable

The cable type with braided metallic screen (e.g. ÖLFLEX by LAPPKABEL, Germany) has been tested and approved by ABB.

### Control panel cable

In remote use, the cable connecting the control panel to the drive must not exceed 3 metres (10 ft). The cable type tested and approved by ABB is used in control panel option kits.

## Connection of a motor temperature sensor to the drive I/O

---



**WARNING!** IEC 60664 requires double or reinforced insulation between live parts and the surface of accessible parts of electrical equipment which are either non-conductive or conductive but not connected to the protective earth.

To fulfil this requirement, the connection of a thermistor (and other similar components) to the digital inputs of the drive can be implemented in three alternate ways:

1. There is double or reinforced insulation between the thermistor and live parts of the motor.
  2. Circuits connected to all digital and analogue inputs of the drive are protected against contact and insulated with basic insulation (the same voltage level as the drive main circuit) from other low voltage circuits.
  3. An external thermistor relay is used. The insulation of the relay must be rated for the same voltage level as the main circuit of the drive. For connection, see *ACS800 Firmware Manual*.
- 

## Routing the cables

Route the motor cable away from other cable routes. Motor cables of several drives can be run in parallel installed next to each other. It is recommended that the motor cable, input power cable and control cables be installed on separate trays. Avoid long parallel runs of motor cables with other cables in order to decrease electromagnetic interference caused by the rapid changes in the drive output voltage.

Where control cables must cross power cables make sure they are arranged at an angle as near to 90 degrees as possible. Do not run extra cables through the drive.

The cable trays must have good electrical bonding to each other and to the grounding electrodes. Aluminium tray systems can be used to improve local equalizing of potential.

A diagram of the cable routing is shown below.

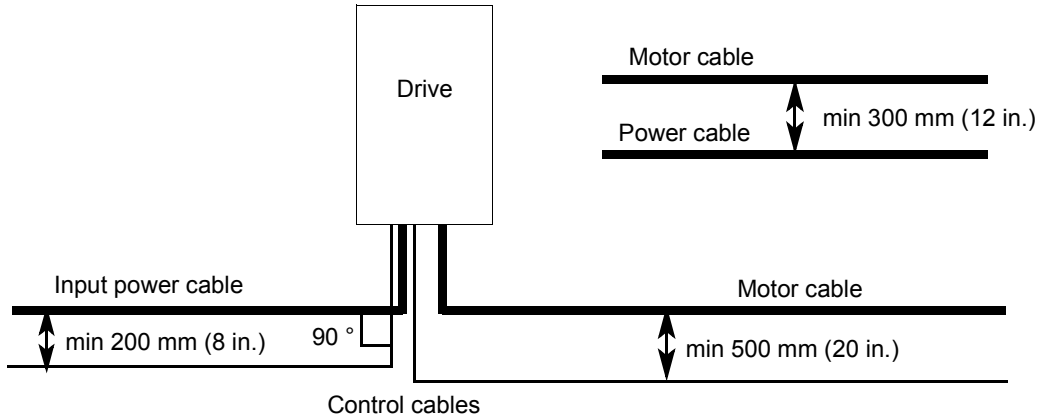

**Control cable ducts**

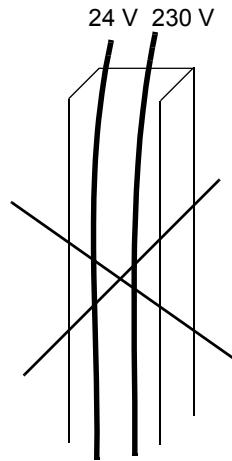

Not allowed unless the 24 V cable is insulated for 230 V or insulated with an insulation sleeving for 230 V.

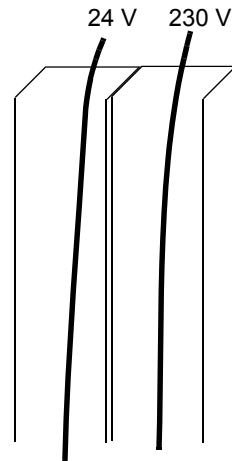

Lead 24 V and 230 V control cables in separate ducts inside the cabinet.



# Electrical installation

---

## What this chapter contains

This chapter instructs in the cabling of the drive.

## Warnings



**WARNING!** Only qualified electricians are allowed to carry out the work described in this chapter. Follow the [Safety instructions](#) on the first pages of this manual. Ignoring the safety instructions can cause injury or death.

---

## Checking the insulation of the assembly

Every drive module has been tested for insulation between the main circuit and the chassis (2500 V rms 50 Hz for 1 second) at the factory. Therefore, do not make any voltage tolerance or insulation resistance tests (e.g. hi-pot or megger) on any part of the drive. Check the insulation of the assembly as follows.

---



**WARNING!** Check the insulation before connecting the drive to the mains. Make sure that the drive is disconnected from the mains (input power).

---

1. Check that the motor cable is disconnected from the drive output terminals U2, V2 and W2.
2. Measure the insulation resistances of the motor cable and the motor between each phase and the Protective Earth by using a measuring voltage of 1 kV DC. The insulation resistance must be higher than 1 Mohm.

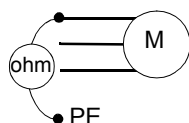

## IT (ungrounded) systems

A drive equipped with no EMC filter or with EMC filter +E210 is suitable for IT (ungrounded systems). If the drive is equipped with EMC filter +E202, disconnect the filter before connecting the drive to an ungrounded system. For detailed instructions on how to do this, please contact your local ABB representative.



**WARNING!** If a drive with EMC filter +E202 is installed on an IT system [an ungrounded power system or a high-resistance-grounded (over 30 ohms) power system], the system will be connected to earth potential through the EMC filter capacitors of the drive. This may cause danger or damage the unit.

---

## Example wiring diagram

The diagram below presents an example for the main wiring. Note that the diagram includes optional components which are not included in a basic delivery (marked \*) and equipment not available as options (marked \*\*).

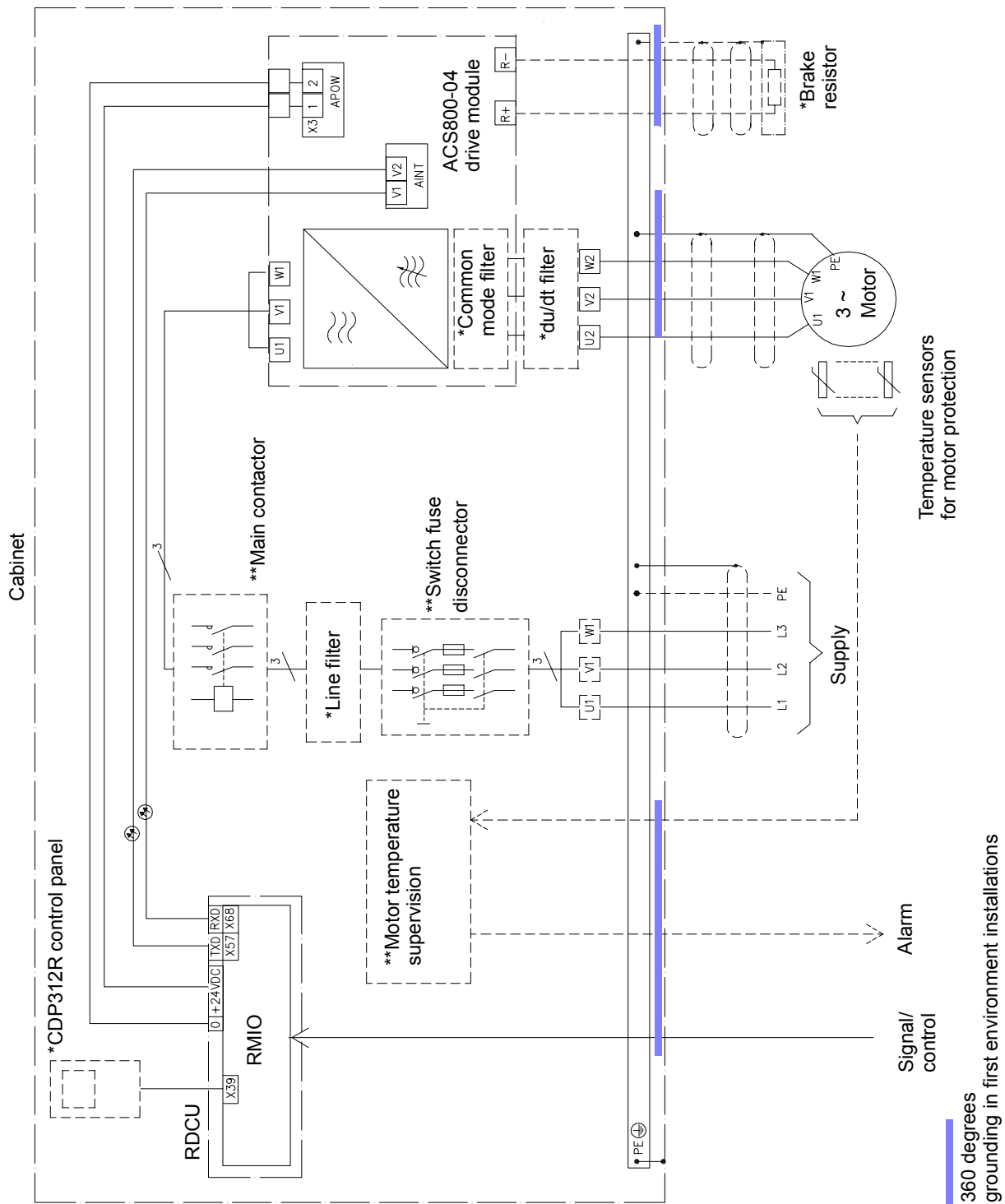

## Power cable connection diagram

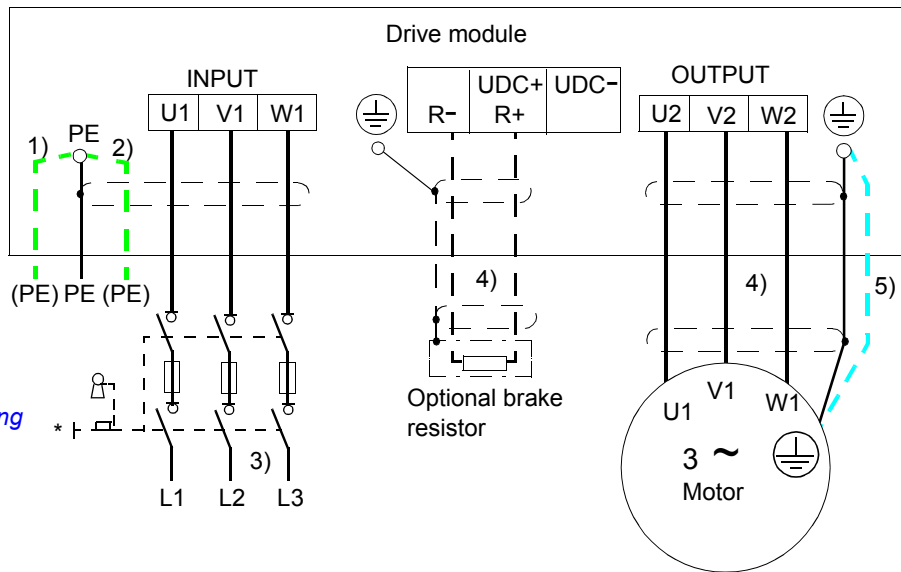

\* For alternatives, see *Planning the electrical installation: Disconnecting device (disconnecting means)*

1), 2)

If shielded cable is used (not required but recommended) and the conductivity of the shield is < 50 % of the conductivity of the phase conductor, use a separate PE cable (1) or a cable with a grounding conductor (2).

Ground the other end of the input cable shield or PE conductor at the distribution board.

3) 360 degrees grounding recommended at the cabinet entry if shielded cable

4) 360 degrees grounding required at the cabinet entry in first environment installations \*\*

5) Use a separate grounding cable if the conductivity of the cable shield is < 50 % of the conductivity of the phase conductor and there is no symmetrically constructed grounding conductor in the cable (see *Planning the electrical installation / Selecting the power cables*).

**Note:**

If there is a symmetrically constructed grounding conductor in the motor cable in addition to the conductive shield, connect the grounding conductor to the grounding terminal at the drive and motor ends.

Do not use an asymmetrically constructed motor cable. Connecting its fourth conductor at the motor end increases bearing currents and causes extra wear.

**Grounding of the motor cable shield at the cabinet entry**

Ground the cable shield 360 degrees at the lead-through of the cabinet.

**Grounding of the motor cable shield at the motor end**

For minimum radio frequency interference:

- ground the cable shield 360 degrees at the lead-through of the motor terminal box

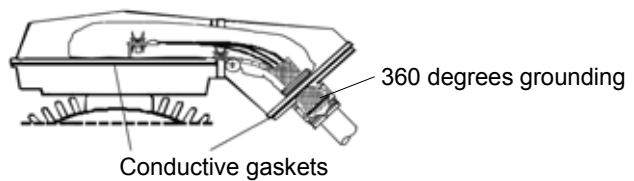

- or ground the cable by twisting the shield as follows: flattened width  $\geq 1/5 \cdot \text{length}$ .

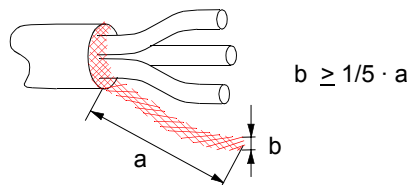

\*\* First environment EMC compliance is defined in *Technical data / CE marking*.

## Grounding of the cable shields

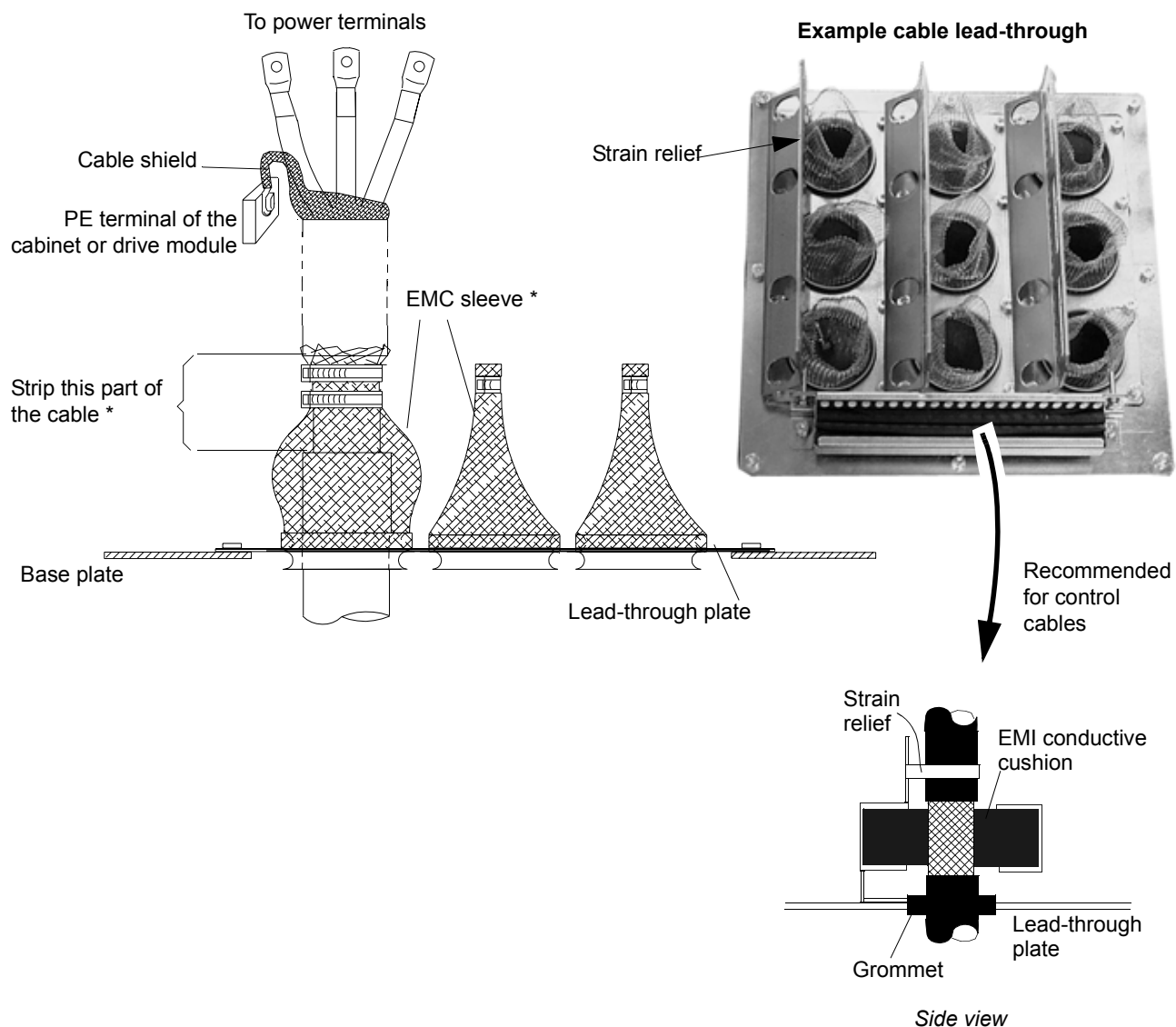

\* required for motor cables in first environment installations. First environment EMC compliance is defined in chapter [Technical data / CE marking](#).

## Fastening US cable lugs

### Example mounting

US cable lugs can be connected directly to the output busbars or to the terminals as follows.

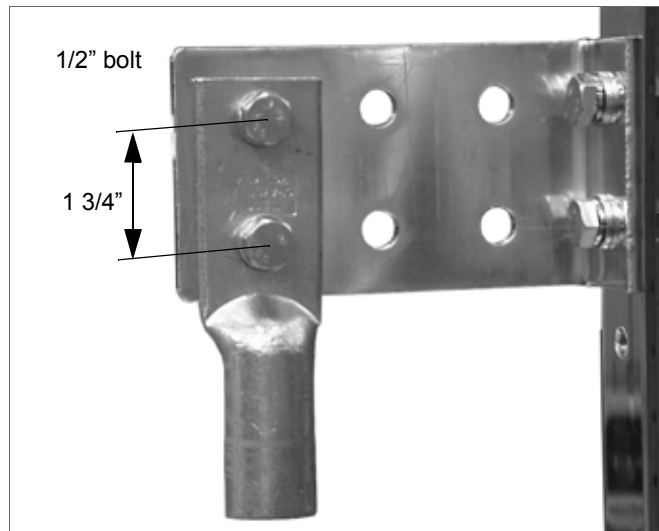

## Connections of the RDCU

The RDCU drive control unit contains the RMIO board where the user's control cables are connected.



**WARNING!** Handle the fibre optic cables with care. When unplugging optic cables, always grab the connector, not the cable itself. Do not touch the ends of the fibres with bare hands as the fibre is extremely sensitive to dirt.

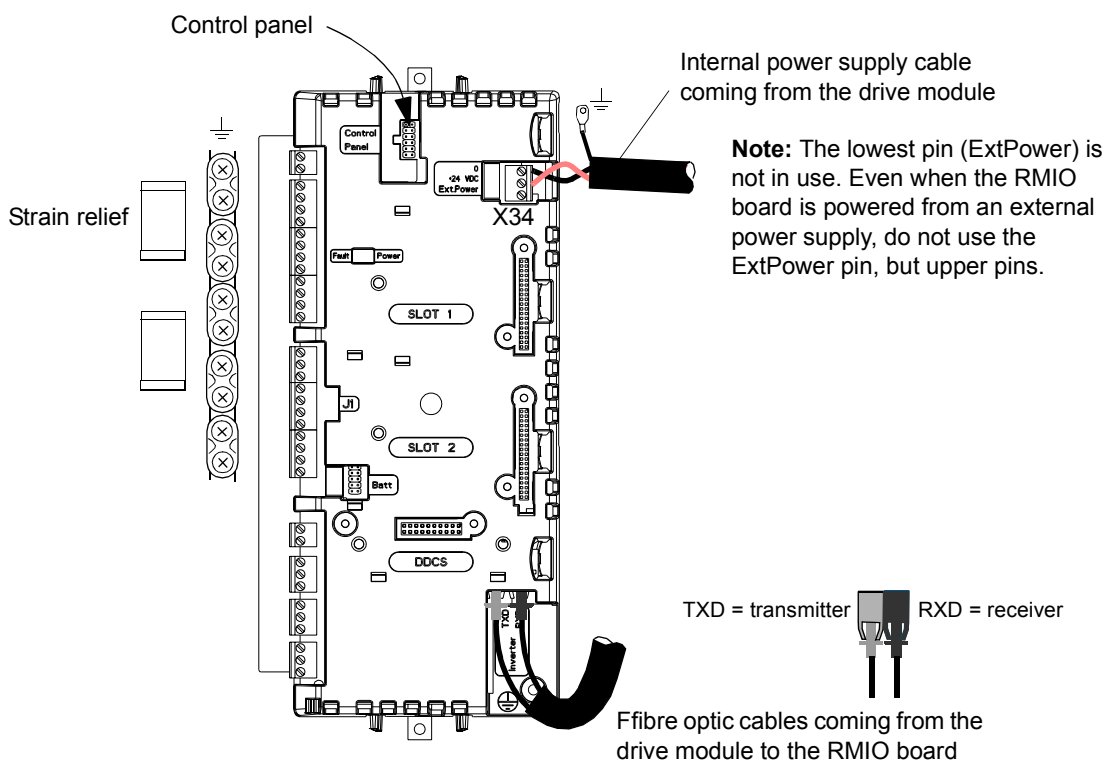

## Connecting the control cables to the RMIO board

Connect the control cables as described below. Connect the conductors to the appropriate detachable terminals of the RMIO board [refer to chapter [Motor control and I/O board \(RMIO\)](#)]. Tighten the screws to secure the connection. Make a 360 degrees EMC grounding at the cabinet entry in first environment installations. First environment EMC compliance is defined in [Technical data / CE marking](#).

### Connecting the shield wires at RMIO board

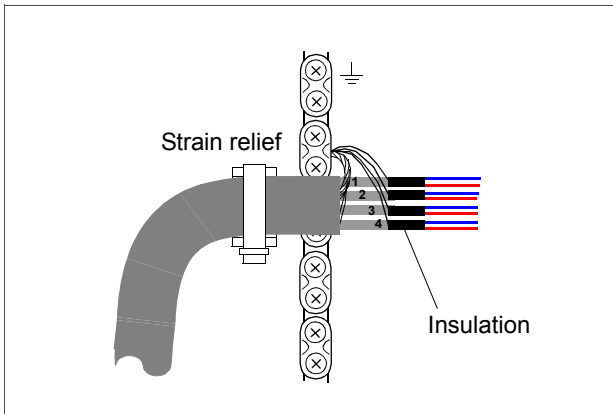

*Double-shielded cable*

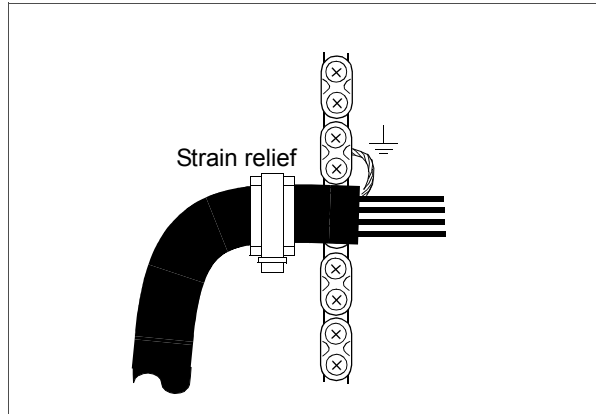

*Single-shielded cable*

Single-shielded cable: Twist the grounding wires of the outer shield and connect them to the nearest grounding clamp. Double-shielded cable: Connect the inner shields and the grounding wires of the outer shield to the nearest grounding clamp.

Do not connect shields of different cables to the same grounding clamp.

Leave the other end of the shield unconnected or ground it indirectly via a few nanofarads high-frequency capacitor (e.g. 3.3 nF / 630 V). The shield can also be grounded directly at both ends if they are *in the same ground line* with no significant voltage drop between the end points.

Keep the signal wire pairs twisted as close to the terminals as possible. Twisting the wire with its return wire reduces disturbances caused by inductive coupling.

### Securing the control cables mechanically

Use strain relief clamps as shown above. Fasten the control cables to the cabinet frame.



## Settings of the cooling fan transformer

The voltage transformer of the cooling fan is located at the top right-hand corner of the drive module. Remove the front cover for adjusting the settings and replace the cover after setting.

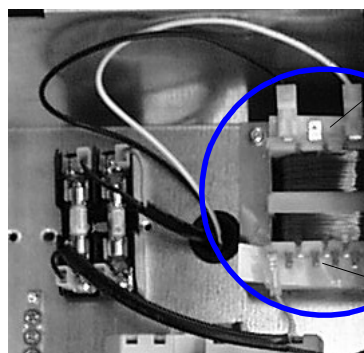

Set to 220 V if the supply frequency is 60 Hz. Set to 230 V if the supply frequency is 50 Hz.

Set according to the supply voltage:  
380 V, 400 V, 415 V, 440 V, 480 V or 500 V; or  
525 V, 575 V, 600 V, 660 V or 690 V.

**Note:** No need to set for 230 V units.

## Installation of optional modules

The optional module (such as a fieldbus adapter, an I/O extension module and the pulse encoder interface) is inserted in the optional module slot of the RMIO board in the RDCU unit and fixed with two screws. See the appropriate optional module manual for the cable connections.

### Cabling of I/O and fieldbus modules

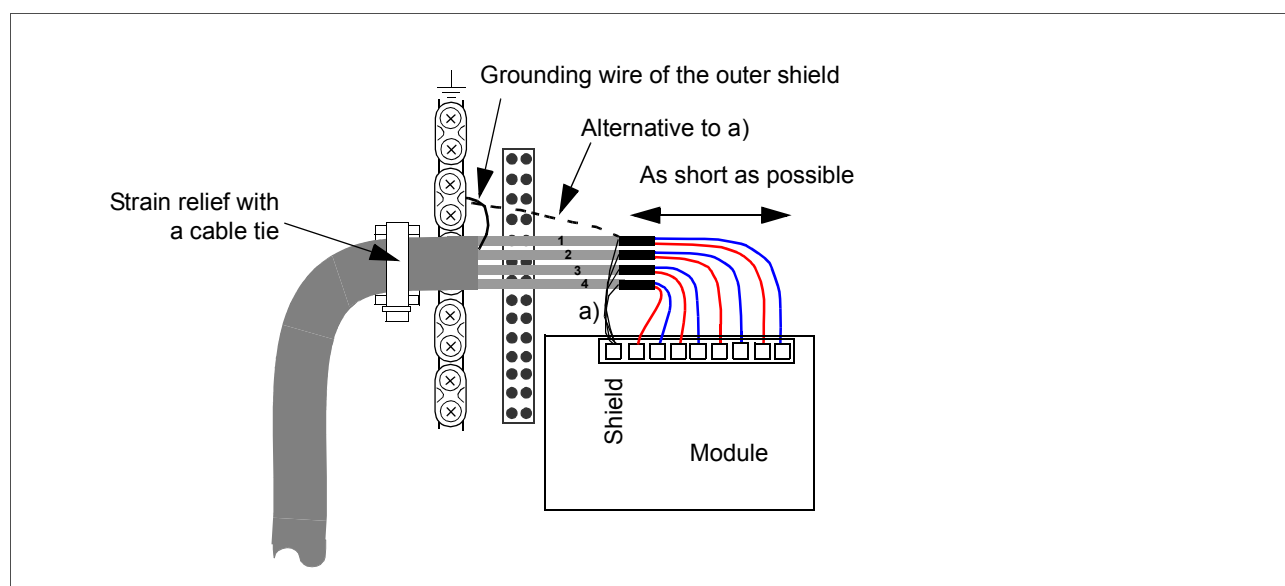

### Pulse encoder module cabling

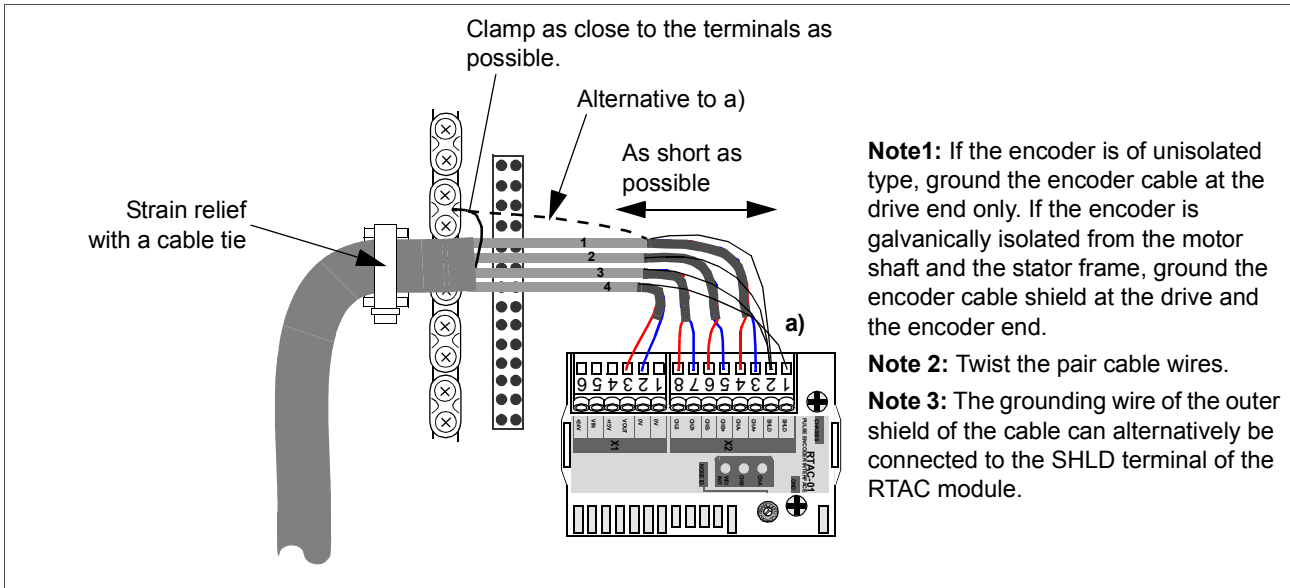

### Fibre optic link

A DDCS fibre optic link is provided via the RDCO optional module for PC tools, master/follower link, NDIO, NTAC, NAI0, AIMA I/O module adapter and fieldbus adapter modules of type Nxxx. See *RDCO User's Manual* [3AFE64492209 (English)] for the connections.

When installing multiple modules on the same channel, connect them in a ring.

### Warning sticker

There are warning stickers in different languages inside the packing box of the drive. Attach a warning sticker in the local language onto the cover of the drive module.

# Motor control and I/O board (RMIO)

---

## What this chapter contains

This chapter shows

- external control connections to the RMIO board for the ACS800 Standard Application Program (Factory Macro)
- specifications of the inputs and outputs of the board.

## To which products this chapter applies

This chapter applies to ACS800 units which employ the RMIO board.

## Note for the ACS800-02 with enclosure extension and the ACS800-07

The connections for the RMIO board shown below apply also to optional terminal block X2 available for the ACS800-02 and ACS800-07. The terminals of the RMIO board are wired to terminal block X2 internally.

Terminals of X2 accept cables from 0.5 to 4.0 mm<sup>2</sup> (22 to 12 AWG). Tightening torque for screw terminals is 0.4 to 0.8 Nm (0.3 to 0.6 lbf ft). For disconnecting wires from spring terminals, use a screw driver with a blade thickness of 0.6 mm (0.024 in.) and width of 3.5 mm (0.138 in.), e.g. PHOENIX CONTACT SZF 1-0,6X3,5.

## Note on external power supply



**WARNING!** If the RMIO board is supplied from an external power source, the loose end of the cable removed from the RMIO board terminal must be secured mechanically to a location where it cannot come into contact with electrical parts. If the screw terminal plug of the cable is removed, the wire ends must be individually insulated.

### External control connections (non-US)

External control cable connections to the RMIO board for the ACS800 Standard Application Program (Factory Macro) are shown below. For external control connections of other application macros and programs, see the appropriate *Firmware Manual*.

**RMIO**

**Terminal block size:**

cables 0.3 to 3.3 mm<sup>2</sup> (22 to 12 AWG)

**Tightening torque:**

0.2 to 0.4 Nm  
(0.2 to 0.3 lbf ft)

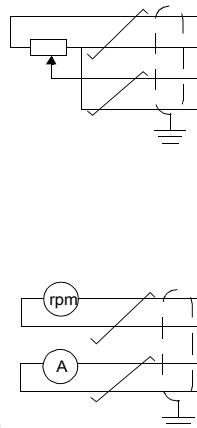

\* optional terminal block in ACS800-02 and ACS800-07

1) Only effective if par. 10.03 is set to REQUEST by the user.

2) 0 = open, 1 = closed

DI4	Ramp times according to
0	parameters 22.02 and 22.03
1	parameters 22.04 and 22.05

3) See par. group 12 CONSTANT SPEEDS.

DI5	DI6	Operation
0	0	Set speed through AI1
1	0	Constant speed 1
0	1	Constant speed 2
1	1	Constant speed 3

4) See parameter 21.09 START INTRL FUNC.

5) Total maximum current shared between this output and optional modules installed on the board.

X2*	RMIO	
X20	X20	
1	1	VREF- Reference voltage -10 VDC, 1 kohm ≤ R <sub>L</sub> ≤ 10 kohm
2	2	AGND
X21	X21	
1	1	VREF+ Reference voltage 10 VDC, 1 kohm ≤ R <sub>L</sub> ≤ 10 kohm
2	2	AGND
3	3	AI1+ Speed reference 0(2) ... 10 V, R <sub>in</sub> > 200 kohm
4	4	AI1-
5	5	AI2+ By default, not in use. 0(4) ... 20 mA, R <sub>in</sub> = 100 ohm
6	6	AI2-
7	7	AI3+ By default, not in use. 0(4) ... 20 mA, R <sub>in</sub> = 100 ohm
8	8	AI3-
9	9	AO1+ Motor speed 0(4)...20 mA ≅ 0...motor nom. speed, R <sub>L</sub> ≤ 700 ohm
10	10	AO1-
11	11	AO2+ Output current 0(4)...20 mA ≅ 0...motor nom. current, R <sub>L</sub> ≤ 700 ohm
12	12	AO2-
X22	X22	
1	1	DI1 Stop/Start
2	2	DI2 Forward/Reverse <sup>1)</sup>
3	3	DI3 Not in use
4	4	DI4 Acceleration & deceleration select <sup>2)</sup>
5	5	DI5 Constant speed select <sup>3)</sup>
6	6	DI6 Constant speed select <sup>3)</sup>
7	7	+24VD +24 VDC max. 100 mA
8	8	+24VD
9	9	DGND1 Digital ground
10	10	DGND2 Digital ground
11	11	DIIL Start interlock (0 = stop) <sup>4)</sup>
X23	X23	
1	1	+24V Auxiliary voltage output, non-isolated, 24 VDC 250 mA <sup>5)</sup>
2	2	GND
X25	X25	
1	1	RO1 Relay output 1: ready
2	2	RO1
3	3	RO1
X26	X26	
1	1	RO2 Relay output 2: running
2	2	RO2
3	3	RO2
X27	X27	
1	1	RO3 Relay output 3: fault (-1)
2	2	RO3
3	3	RO3

### External control connections (US)

External control cable connections to the RMIO board for the ACS800 Standard Application Program (Factory Macro US version) are shown below. For external control connections of other application macros and programs, see the appropriate *Firmware Manual*.

**RMIO**

**Terminal block size:**

cables 0.3 to 3.3 mm<sup>2</sup> (22 to 12 AWG)

**Tightening torque:**

0.2 to 0.4 Nm (0.2 to 0.3 lbf ft)

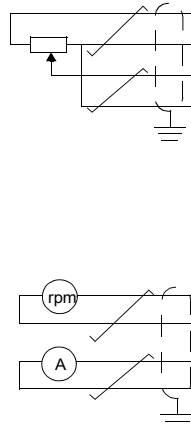

\* optional terminal block in ACS800-U2 and ACS800-U7

1) Only effective if par. 10.03 is set to REQUEST by the user.

2) 0 = open, 1 = closed

DI4	Ramp times according to
0	parameters 22.02 and 22.03
1	parameters 22.04 and 22.05

3) See par. group 12 CONSTANT SPEEDS.

DI5	DI6	Operation
0	0	Set speed through AI1
1	0	Constant speed 1
0	1	Constant speed 2
1	1	Constant speed 3

4) See parameter 21.09 START INTRL FUNC.

5) Total maximum current shared between this output and optional modules installed on the board.

X2*	RMIO			
X20	X20	1	VREF-	Reference voltage -10 VDC, $1\text{ kohm} \leq R_L \leq 10\text{ kohm}$
		2	AGND	
X21	X21	1	VREF+	Reference voltage 10 VDC, $1\text{ kohm} \leq R_L \leq 10\text{ kohm}$
		2	AGND	
		3	AI1+	Speed reference 0(2) ... 10 V, $R_{in} > 200\text{ kohm}$
		4	AI1-	
		5	AI2+	By default, not in use. 0(4) ... 20 mA, $R_{in} = 100\text{ ohm}$
		6	AI2-	
		7	AI3+	By default, not in use. 0(4) ... 20 mA, $R_{in} = 100\text{ ohm}$
		8	AI3-	
		9	AO1+	Motor speed 0(4)...20 mA $\approx$ 0...motor nom. speed, $R_L \leq 700\text{ ohm}$
		10	AO1-	
		11	AO2+	Output current 0(4)...20 mA $\approx$ 0...motor nom. current, $R_L \leq 700\text{ ohm}$
		12	AO2-	
X22	X22	1	DI1	Start ( $\_ \_$ )
		2	DI2	Stop ( $\_ \_$ )
		3	DI3	Forward/Reverse <sup>1)</sup>
		4	DI4	Acceleration & deceleration select <sup>2)</sup>
		5	DI5	Constant speed select <sup>3)</sup>
		6	DI6	Constant speed select <sup>3)</sup>
		7	+24VD	+24 VDC max. 100 mA
		8	+24VD	
		9	DGND1	Digital ground
		10	DGND2	Digital ground
		11	DIIL	Start interlock (0 = stop) <sup>4)</sup>
X23	X23	1	+24V	Auxiliary voltage output, non-isolated, 24 VDC 250 mA <sup>5)</sup>
		2	GND	
X25	X25	1	RO1	Relay output 1: ready
		2	RO1	
		3	RO1	
X26	X26	1	RO2	Relay output 2: running
		2	RO2	
		3	RO2	
X27	X27	1	RO3	Relay output 3: fault (-1)
		2	RO3	
		3	RO3	

## RMIO board specifications

### Analogue inputs

---

	With Standard Application Program two programmable differential current inputs (0 mA / 4 mA ... 20 mA, $R_{in} = 100 \text{ ohm}$ ) and one programmable differential voltage input (-10 V / 0 V / 2 V ... +10 V, $R_{in} > 200 \text{ kohm}$ ).
	The analogue inputs are galvanically isolated as a group.
Isolation test voltage	500 VAC, 1 min
Max. common mode voltage between the channels	$\pm 15 \text{ VDC}$
Common mode rejection ratio	$\geq 60 \text{ dB}$ at 50 Hz
Resolution	0.025 % (12 bit) for the -10 V ... +10 V input. 0.5 % (11 bit) for the 0 ... +10 V and 0 ... 20 mA inputs.
Inaccuracy	$\pm 0.5 \%$ (Full Scale Range) at 25 °C (77 °F). Temperature coefficient: $\pm 100 \text{ ppm}/^\circ\text{C}$ ( $\pm 56 \text{ ppm}/^\circ\text{F}$ ), max.

### Constant voltage output

---

Voltage	+10 VDC, 0, -10 VDC $\pm 0.5 \%$ (Full Scale Range) at 25 °C (77 °F). Temperature coefficient: $\pm 100 \text{ ppm}/^\circ\text{C}$ ( $\pm 56 \text{ ppm}/^\circ\text{F}$ ) max.
Maximum load	10 mA
Applicable potentiometer	1 kohm to 10 kohm

### Auxiliary power output

---

Voltage	24 VDC $\pm 10 \%$ , short circuit proof
Maximum current	250 mA (shared between this output and optional modules installed on the RMIO)

### Analogue outputs

---

	Two programmable current outputs: 0 (4) to 20 mA, $R_L \leq 700 \text{ ohm}$
Resolution	0.1 % (10 bit)
Inaccuracy	$\pm 1 \%$ (Full Scale Range) at 25 °C (77 °F). Temperature coefficient: $\pm 200 \text{ ppm}/^\circ\text{C}$ ( $\pm 111 \text{ ppm}/^\circ\text{F}$ ) max.

### Digital inputs

---

	With Standard Application Program six programmable digital inputs (common ground: 24 VDC, -15 % to +20 %) and a start interlock input. Group isolated, can be divided in two isolated groups (see <a href="#">Isolation and grounding diagram</a> below).
	Thermistor input: 5 mA, $< 1.5 \text{ kohm} \hat{=} \text{"1"}$ (normal temperature), $> 4 \text{ kohm} \hat{=} \text{"0"}$ (high temperature), open circuit $\hat{=} \text{"0"}$ (high temperature).
	Internal supply for digital inputs (+24 VDC): short-circuit proof. An external 24 VDC supply can be used instead of the internal supply.
Isolation test voltage	500 VAC, 1 min
Logical thresholds	$< 8 \text{ VDC} \hat{=} \text{"0"}$ , $> 12 \text{ VDC} \hat{=} \text{"1"}$
Input current	DI1 to DI 5: 10 mA, DI6: 5 mA
Filtering time constant	1 ms

### Relay outputs

---

	Three programmable relay outputs
Switching capacity	8 A at 24 VDC or 250 VAC, 0.4 A at 120 VDC
Minimum continuous current	5 mA rms at 24 VDC
Maximum continuous current	2 A rms
Isolation test voltage	4 kVAC, 1 minute

### DDCS fibre optic link

---

With optional communication adapter module RDCO. Protocol: DDCS (ABB Distributed Drives Communication System)

### 24 VDC power input

---

Voltage	24 VDC $\pm$ 10 %
Typical current consumption (without optional modules)	250 mA
Maximum current consumption	1200 mA (with optional modules inserted)

The terminals on the RMIO board as well as on the optional modules attachable to the board fulfil the Protective Extra Low Voltage (PELV) requirements stated in EN 50178 provided that the external circuits connected to the terminals also fulfil the requirements.

### Isolation and grounding diagram

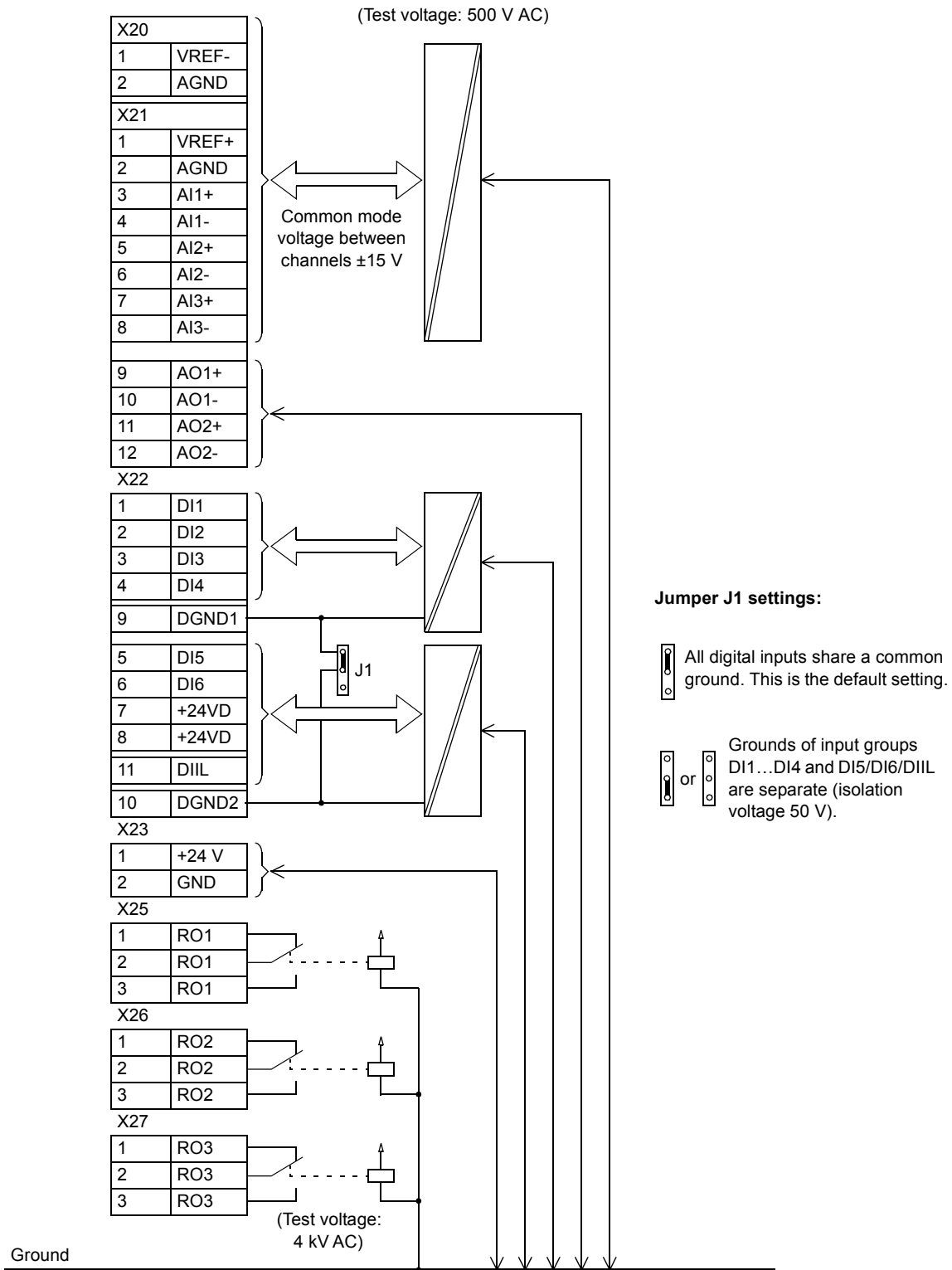



# Maintenance

---

## What this chapter contains

This chapter contains preventive maintenance instructions.

## Safety



**WARNING!** Read the [Safety instructions](#) on the first pages of this manual before performing any maintenance on the equipment. Ignoring the safety instructions can cause injury or death.

---



**WARNING!** The drive module is heavy [frame size R7: 100 kg (220 lb), frame size R8: 200 kg (441 lb)]. Lift the module by the upper part using the lifting lugs attached to the top of the unit. Do not tilt the drive module. **The centre of gravity of the unit is high.** The unit will overturn from a tilt of about 6 degrees. **An overturning unit can cause physical injury.**

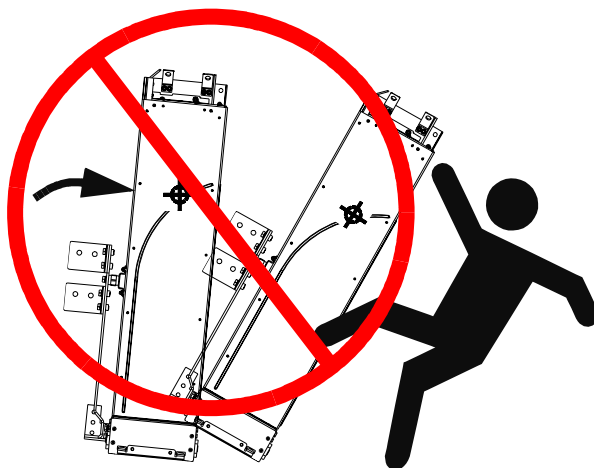
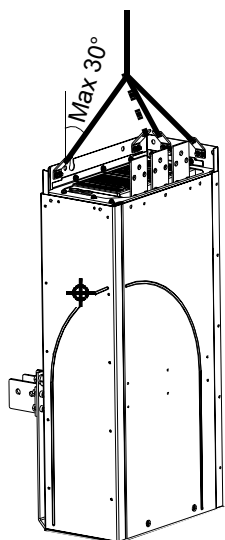

**Do not tilt!**

---

## Maintenance intervals

If installed in an appropriate environment, the drive requires very little maintenance. This table lists the routine maintenance intervals recommended by ABB.

Interval	Maintenance	Instruction
Every year when stored	Capacitor reforming	See <a href="#">Reforming</a> .
Every 6 to 12 months (depending on the dustiness of the environment)	Heatsink temperature check and cleaning	See <a href="#">Heatsink</a> .
Every 6 years	Cooling fan change	See <a href="#">Fan</a> .
Every 10 years	Capacitor change	See <a href="#">Capacitors</a> .

# Layout

The layout stickers of the drive are shown below. The stickers show all possible components. Not all of them are present in each delivery or described here. Components that need to be changed regularly are listed below:

Designation	Component
Y41	Cooling fan
C_	Capacitors

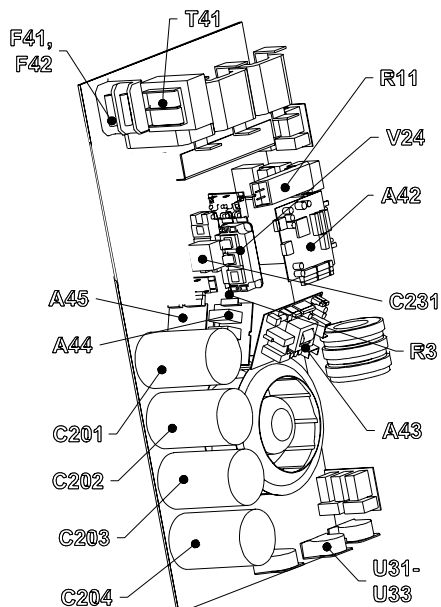
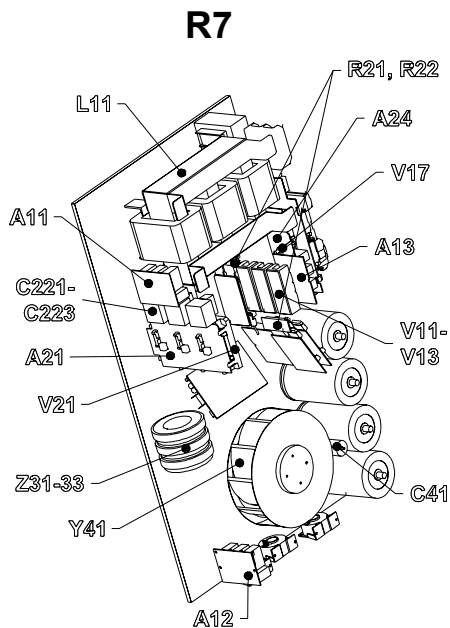

Code: 64572261

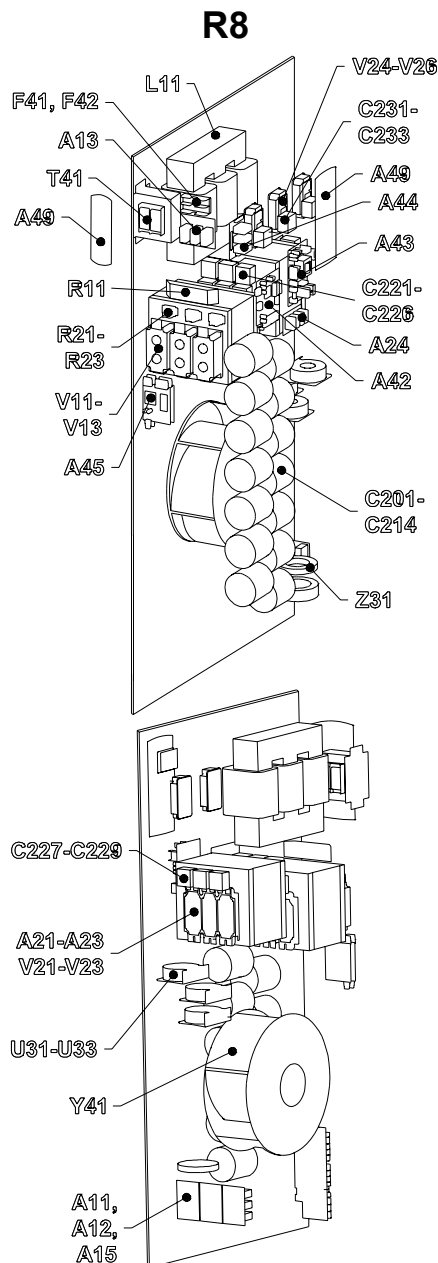

Code: 64601423

## Heatsink

Check the cleanliness of the cabinet and the surroundings. When necessary, clean the interior of the cabinet with a soft brush and a vacuum cleaner.

The module heatsink fins pick up dust from the cooling air. The drive runs into overtemperature warnings and faults if the heatsink is not clean. When necessary, contact ABB for cleaning of the heatsink.

## Fan

The lifespan of the cooling fan of the drive module is about 50 000 hours. The actual lifespan depends on the running time of the fan, ambient temperature and dust concentration. See the appropriate ACS800 firmware manual for the actual signal which indicates the running time of the cooling fan.

Replacement fans are available from ABB. Do not use other than ABB specified spare parts.

### Replacing the fan (R7)

1. Remove the front cover.
2. Disconnect the discharging resistor wire(s).
3. Remove the DC capacitor pack by undoing the red fixing screws and pulling the pack out.
4. Disconnect the fan supply wires (detachable connector).
5. Disconnect the fan capacitor wires.
6. Disconnect the AINP board wires from connectors X1 and X2.
7. Undo the red fixing screws of the fan cassette.
8. Press the snap-on holders to release the side cover.
9. Lift the handle and pull the fan cassette out.
10. Install the new fan and fan capacitor in reverse order to the above.

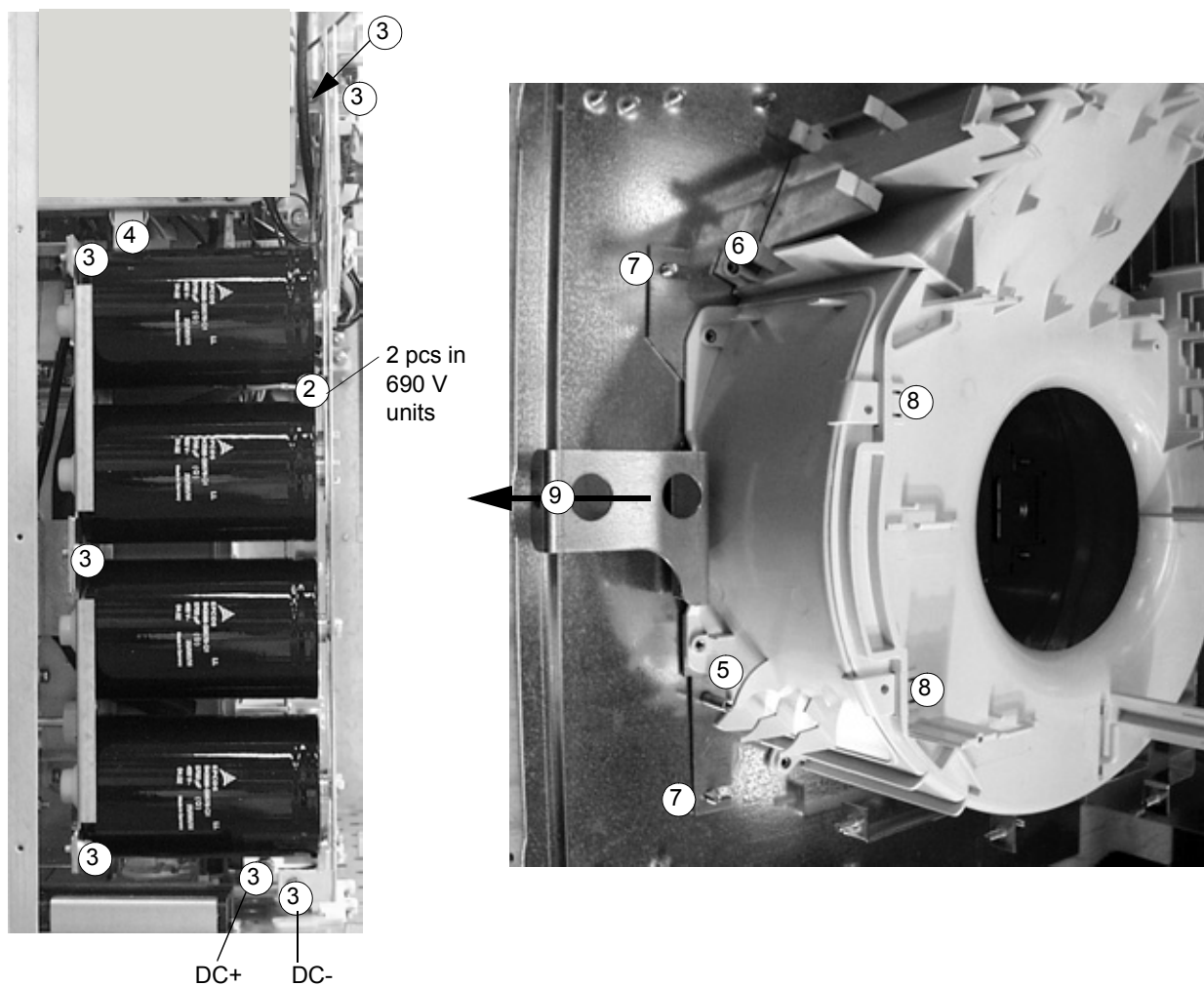

### Replacing the fan (R8)

1. Remove the front cover.
2. Disconnect the fan capacitor and power supply wires.
3. Undo the red fastening screws of the plastic side cover of the fan. Shift the cover to the right to free its right-hand edge and lift the cover off.
4. Undo the red fastening screws of the fan.
5. Lift the fan out of the cabinet.
6. Install the new fan and fan capacitor in reverse order to the above.

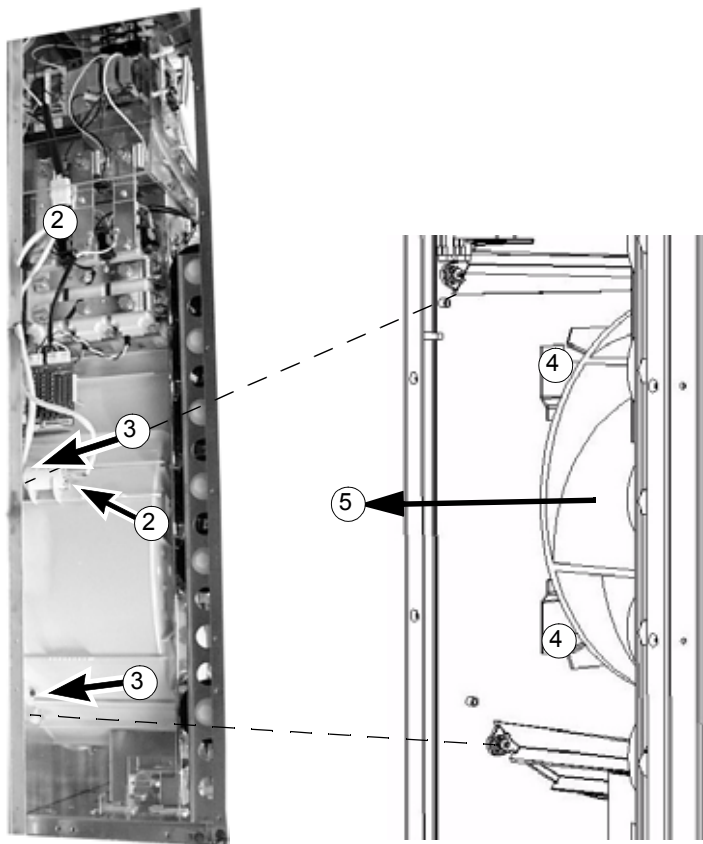

## Capacitors

The drive intermediate circuit employs several electrolytic capacitors. Their lifespan is at least 90 000 hours depending on the operating time of the drive, loading and ambient temperature. Capacitor life can be prolonged by lowering the ambient temperature.

It is not possible to predict a capacitor failure. Capacitor failure is usually followed by damage to the unit and an input cable fuse failure, or a fault trip. Contact ABB if capacitor failure is suspected. Replacements are available from ABB. Do not use other than ABB specified spare parts.

### Reforming

Reform (re-age) spare part capacitors once a year according to *ACS 600/800 Capacitor Reforming Guide* [code: 64059629 (English)].

### Replacing the capacitor pack (R7)

Replace the capacitor pack as described in section [Replacing the fan \(R7\)](#).

### Replacing the capacitor pack (R8)

1. Remove the front cover. Remove the profiled side plate.
2. Disconnect the discharging resistor wires.
3. Undo the fastening screws.
4. Lift the capacitor pack out.
5. Install the new capacitor pack in reverse order to the above.

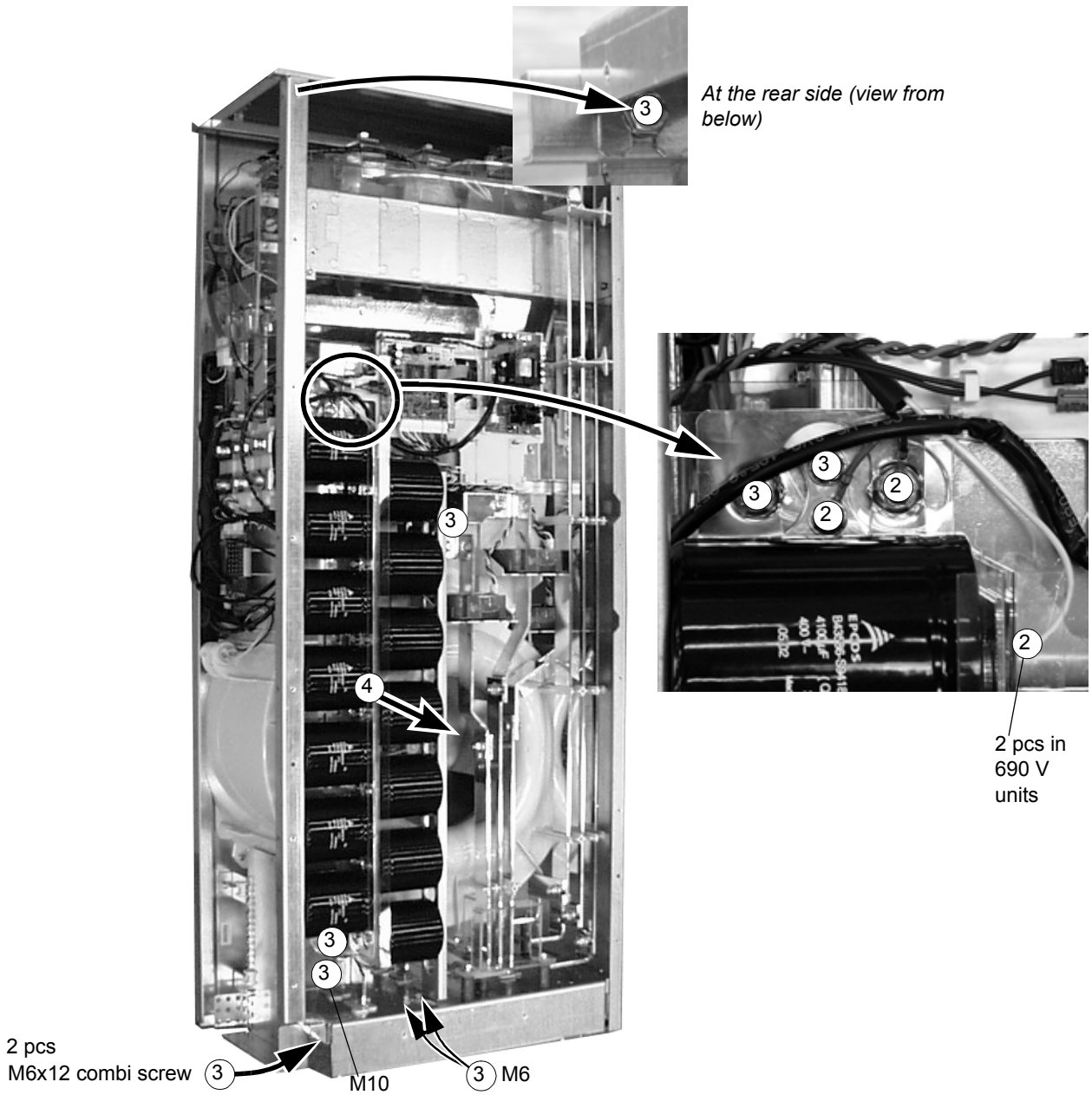



## Replacing the drive module

- Disconnect the input power cable from the module.
- Disconnect the power supply cable and the fibre optic cables from the RMIO board and coil them on the top of the converter module.
- Disconnect the busbars outside the module.
- Undo the upper fastening screws of the module (if used).
- Disconnect the pedestal from the module by undoing the fastening (a) and busbar connecting (b) screws.

Frame size R7

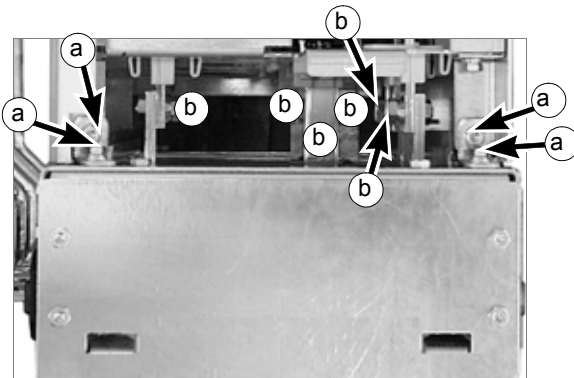

Ⓐ M6 combi screw  
Tightening torque: 5 Nm (3.7 lbf ft)

Ⓑ M8x25 combi screw  
Tightening torque: 15...22 Nm  
(11...16 lbf ft)

Frame size R8

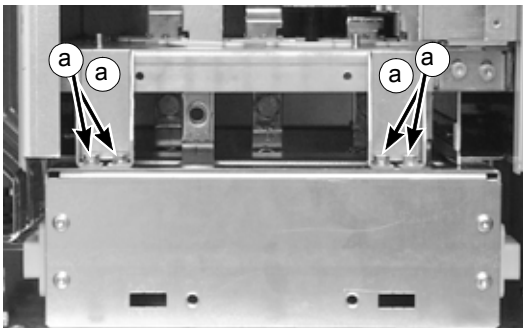

Ⓐ M6x16 combi screws  
Tightening torque: 5 Nm (3.7 lbf ft)

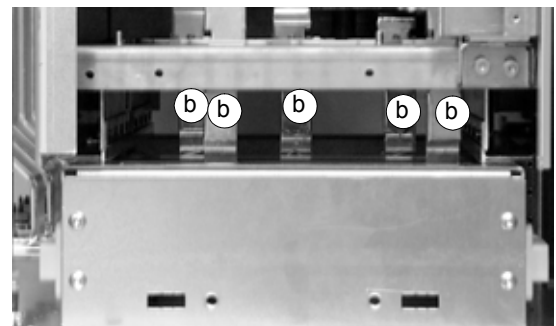

Ⓑ M10x25 combi screws  
Tightening torque: 30...44 Nm (22...32 lbf ft)

- Secure the module from the lifting hooks at the top.
- Pull the module from the cabinet onto a pallet truck.
- Install the new module in reverse order to the above.

## LEDs

This table describes LEDs of the drive.

Where	LED	When the LED is lit
RMIO board	Red	Drive in fault state
	Green	The power supply on the board is OK.
Control panel mounting platform	Red	Drive in fault state
	Green	The main + 24 V power supply for the control panel and the RMIO board is OK.
AINT board	V204 (green)	+5 V voltage of the board is OK.
	V309 (red)	Prevention of unexpected start is ON.
	V310 (green)	IGBT control signal transmission to the gate driver control boards is enabled.

# Technical data

## What this chapter contains

This chapter contains the technical specifications of the drive, e.g. the ratings, sizes and technical requirements, provisions for fulfilling the requirements for CE and other markings, and warranty policy.

## IEC ratings

The IEC ratings for the ACS800-04 with 50 Hz and 60 Hz supplies are given below. The symbols are described below the table.

ACS800-04 size	Nominal ratings		No-overload use	Light-overload use		Heavy-duty use		Frame size	Air flow m <sup>3</sup> /h	Heat dissipation W
	$I_{cont.max}$ A	$I_{max}$ A	$P_{cont.max}$ kW	$I_{2N}$ A	$P_N$ kW	$I_{2hd}$ A	$P_{hd}$ kW			
Three-phase supply voltage 208 V, 220 V, <b>230 V</b> or 240 V										
-0080-2	214	326	55	211	55	170	45	R7	540	2900
-0100-2	253	404	75	248	75	202	55	R7	540	3450
-0120-2	295	432	90	290	90	240 <sup>4)</sup>	55	R7	540	4050
-0140-2	405	588	110	396	110	316	90	R8	1220	5300
-0170-2	447	588	132	440	132	340	90	R8	1220	6100
-0210-2	528	588	160	516	160	370	110	R8	1220	6700
-0230-2	613	840	160	598	160	480	132	R8	1220	7600
-0260-2	693	1017	200	679	200	590 <sup>2)</sup>	160	R8	1220	7850
-0300-2	720	1017	200	704	200	635 <sup>3)</sup>	200	R8	1220	8300
Three-phase supply voltage 380 V, <b>400 V</b> or 415 V										
-0140-3	206	326	110	202	110	163	90	R7	540	3000
-0170-3	248	404	132	243	132	202	110	R7	540	3650
-0210-3	289	432	160	284	160	240 <sup>1)</sup>	132	R7	540	4300
-0260-3	445	588	200	440	200	340	160	R8	1220	6600
-0320-3	521	588	250	516	250	370	200	R8	1220	7150
-0400-3	602	840	315	590	315	477	250	R8	1220	8100
-0440-3	693	1017	355	679	355	590 <sup>2)</sup>	315	R8	1220	8650
-0490-3	720	1017	400	704	400	635 <sup>3)</sup>	355	R8	1220	9100
Three-phase supply voltage 380 V, 400 V, 415 V, 440 V, 460 V, 480 V or <b>500 V</b>										
-0170-5	196	326	132	192	132	162	110	R7	540	3000
-0210-5	245	384	160	240	160	192	132	R7	540	3800
-0260-5	289	432	200	284	200	224	160	R7	540	4500
-0320-5	440	588	250	435	250	340	200	R8	1220	6850
-0400-5	515	588	315	510	315	370	250	R8	1220	7800
-0440-5	550	840	355	545	355	490	315	R8	1220	7600
-0490-5	602	840	400	590	400	515 <sup>2)</sup>	355	R8	1220	8100
-0550-5	684	1017	450	670	450	590 <sup>2)</sup>	400	R8	1220	9100
-0610-5	718	1017	500	704	500	632 <sup>3)</sup>	450	R8	1220	9700

ACS800-04 size	Nominal ratings		No-overload use	Light-overload use		Heavy-duty use		Frame size	Air flow m <sup>3</sup> /h	Heat dissipation W
	$I_{\text{cont.max}}$ A	$I_{\text{max}}$ A	$P_{\text{cont.max}}$ kW	$I_{2N}$ A	$P_N$ kW	$I_{2hd}$ A	$P_{hd}$ kW			
Three-phase supply voltage 525 V, 550 V, 575 V, 600 V, 660 V or 690 V										
-0140-7	134	190	132	125	110	95	90	R7	540	2800
-0170-7	166	263	160	155	132	131	110	R7	540	3550
-0210-7	166/203*	294	160	165/195*	160	147	132	R7	540	4250
-0260-7	175/230*	326	160/200*	175/212*	160/200*	163	160	R7	540	4800
-0320-7	315	433	315	290	250	216	200	R8	1220	6150
-0400-7	353	548	355	344	315	274	250	R8	1220	6650
-0440-7	396	656	400	387	355	328	315	R8	1220	7400
-0490-7	445	775	450	426	400	387	355	R8	1220	8450
-0550-7	488	853	500	482	450	426	400	R8	1220	8300
-0610-7	560	964	560	537	500	482	450	R8	1220	9750

PDM code: 00096931-G

- 1) 50 % overload is available for one minute every 5 minutes if ambient temperature is less than 25 °C. If ambient temperature is 40 °C, max. available overload is 37 %.
- 2) 50 % overload is available for one minute every 5 minutes if ambient temperature is less than 30 °C. If ambient temperature is 40 °C, max. available overload is 40 %.
- 3) 50 % overload is available one minute every 5 minutes if ambient temperature is less than 20 °C. If ambient temperature is 40 °C, max. available overload is 30 %.
- 4) 50 % overload is available one minute every 5 minutes if ambient temperature is less than 35 °C. If ambient temperature is 40 °C, max. available overload is 45 %.

\* higher value applicable if output frequency is above 41 Hz

## Symbols

### Nominal ratings

$I_{\text{cont.max}}$  continuous rms output current. No overload capability at 40 °C.

$I_{\text{max}}$  maximum output current. Available for 10 s at start, otherwise as long as allowed by drive temperature.

### Typical ratings:

#### No-overload use

$P_{\text{cont.max}}$  typical motor power. The power ratings apply to most IEC 34 motors at the nominal voltage, 230 V, 400 V, 500 V or 690 V.

#### Light-overload use (10 % overload capability)

$I_{2N}$  continuous rms current. 10 % overload is allowed for one minute every 5 minutes.

$P_N$  typical motor power. The power ratings apply to most IEC 34 motors at the nominal voltage, 230 V, 400 V, 500 V or 690 V.

#### Heavy-duty use (50 % overload capability)

$I_{2hd}$  continuous rms current. 50 % overload is allowed for one minute every 5 minutes.

$P_{hd}$  typical motor power. The power ratings apply to most IEC 34 motors at the nominal voltage, 230 V, 400 V, 500 V or 690 V.

## Sizing

The current ratings are the same regardless of the supply voltage within one voltage range. To achieve the rated motor power given in the table, the rated current of the drive must be higher than or equal to the rated motor current.

**Note 1:** The maximum allowed motor shaft power is limited to  $1.5 \cdot P_{hd}$ ,  $1.1 \cdot P_N$  or  $P_{cont.max}$  (whichever value is greatest). If the limit is exceeded, motor torque and current are automatically restricted. The function protects the input bridge of the drive against overload. If the condition exists for 5 minutes, the limit is set to  $P_{cont.max}$ .

**Note 2:** The ratings apply at ambient temperature of 40 °C (104 °F). In lower temperatures the ratings are higher (except  $I_{max}$ ).

**Note 3:** Use the DriveSize PC tool for a more accurate dimensioning if the ambient temperature is below 40 °C (104 °F) or the drive is loaded cyclically.

## Derating

The load capacity (current and power) decreases if the installation site altitude exceeds 1000 metres (3281 ft), or if the ambient temperature exceeds 40 °C (104 °F).

**Note:** If the ingoing cooling air temperature of the drive module is max. 40 °C (104 °F), no derating of the drive output current is needed despite the cabinet temperature rising over 40 °C (104 °F).

### Temperature derating

In the temperature range of +40 °C (+104 °F) to +50 °C (+122 °F), the rated output current is decreased by 1 % for every additional 1 °C (1.8 °F). The output current is calculated by multiplying the current given in the rating table by the derating factor.

**Example** If the ambient temperature is 50 °C (+122 °F), the derating factor is  $100 \% - 1 \frac{\%}{^{\circ}\text{C}} \cdot 10 ^{\circ}\text{C} = 90 \%$  or 0.90. The output current is then  $0.90 \cdot I_{2N}$ ,  $0.90 \cdot I_{2hd}$  or  $0.90 \cdot I_{cont.max}$ .

### Altitude derating

At altitudes from 1000 to 4000 m (3281 to 13123 ft) above sea level, the derating is 1 % for every 100 m (328 ft). For a more accurate derating, use the DriveSize PC tool. If the installation site is higher than 2000 m (6600 ft) above sea level, please contact your local ABB distributor or office for further information.

## Mains cable fuses

Fuses for short-circuit protection of the mains cable are listed below. The fuses also protect the adjoining equipment of the drive in case of a short-circuit inside the drive.

**Check that the operating time of the fuse is below 0.5 seconds.** The operating time depends on the supply network impedance and the cross-sectional area, material and length of the supply cable. In case the 0.5 seconds operating time is exceeded with gG fuses, ultrarapid (aR) fuses will in most cases reduce the operating time to an acceptable level. See also *Planning the electrical installation: Thermal overload and short-circuit protection*. For UL recognized fuses, see [US tables](#).

**Note 1:** In multicable installations, install only one fuse per phase (not one fuse per conductor).

**Note 2:** Larger fuses must not be used.

**Note 3:** Fuses from other manufacturers can be used if they meet the ratings.

## Standard gG fuses

ACS800-04 size	Input current A	Fuse					
		A	A <sup>2</sup> s	V	Manufacturer	Type	IEC size
Three-phase supply voltage 208 V, 220 V, <b>230 V</b> or 240 V							
-0080-2	201	250	550 000	500	ABB Control	OFAF1H250	1
-0100-2	239	315	1 100 000	500	ABB Control	OFAF2H315	2
-0120-2	285	315	1 100 000	500	ABB Control	OFAF2H315	2
-0140-2	391	500	2 900 000	500	ABB Control	OFAF3H500	3
-0170-2	428	500	2 900 000	500	ABB Control	OFAF3H500	3
-0210-2	506	630	4 000 000	500	ABB Control	OFAF3H630	3
-0230-2	599	630	4 000 000	500	ABB Control	OFAF3H630	3
-0260-2	677	800	7 400 000	500	ABB Control	OFAF3H800	3
-0300-2	707	800	7 400 000	500	ABB Control	OFAF3H800	3
Three-phase supply voltage 380 V, <b>400 V</b> or 415 V							
-0140-3	196	250	550 000	500	ABB Control	OFAF1H250	1
-0170-3	237	315	1 100 000	500	ABB Control	OFAF2H315	2
-0210-3	286	315	1 100 000	500	ABB Control	OFAF2H315	2
-0260-3	438	500	2 900 000	500	ABB Control	OFAF3H500	3
-0320-3	501	630	4 000 000	500	ABB Control	OFAF3H630	3
-0400-3	581	630	4 000 000	500	ABB Control	OFAF3H630	3
-0440-3	674	800	7 400 000	500	ABB Control	OFAF3H800	3
-0490-3	705	800	7 400 000	500	ABB Control	OFAF3H800	3
Three-phase supply voltage 380 V, 400 V, 415 V, 440 V, 460 V, 480 V or <b>500 V</b>							
-0170-5	191	250	550 000	500	ABB Control	OFAF1H250	1
-0210-5	243	315	1 100 000	500	ABB Control	OFAF2H315	2
-0260-5	291	315	1 100 000	500	ABB Control	OFAF2H315	2
-0320-5	424	500	2 900 000	500	ABB Control	OFAF3H500	3
-0400-5	498	630	4 000 000	500	ABB Control	OFAF3H630	3
-0440-5	543	630	4 000 000	500	ABB Control	OFAF3H630	3
-0490-5	590	630	4 000 000	500	ABB Control	OFAF3H630	3
-0550-5	669	800	7 400 000	500	ABB Control	OFAF3H800	3
-0610-5	702	800	7 400 000	500	ABB Control	OFAF3H800	3
Three-phase supply voltage 525 V, 550 V, 575 V, 600 V, 660 V or <b>690 V</b>							
-0140-7	126	160	220 000	690	ABB Control	OFAA1GG160	1
-0170-7	156	200	350 000	690	ABB Control	OFAA1GG200	1
-0210-7	158/191*	250	700 000	690	ABB Control	OFAA2GG250	2
-0260-7	166/217*	250	700 000	690	ABB Control	OFAA2GG250	2
-0320-7	298	315	820 000	690	ABB Control	OFAA2GG315	2
-0400-7	333	400	1 300 000	690	ABB Control	OFAA3GG400	3
-0440-7	377	500	3 800 000	690	ABB Control	OFAA3H500	3
-0490-7	423	500	3 800 000	690	ABB Control	OFAA3H500	3
-0550-7	468	500	3 800 000	690	ABB Control	OFAA3H500	3
-0610-7	533	630	10 000 000	690	Bussmann	630NH3G-690 **	3

PDM code: 00096931-G

\* output frequencies above 41 Hz

\*\* rated braking capacity only up to 50 kA

## Ultrarapid (aR) fuses

ACS800-04 size	Input current A	Fuse					
		A	A <sup>2</sup> s	V	Manufacturer	Type DIN 43620 	Size
Three-phase supply voltage 208 V, 220 V, <b>230 V</b> or 240 V							
-0080-2	201	400	105 000	690	Bussmann	170M3819	DIN1*
-0100-2	239	500	145 000	690	Bussmann	170M5810	DIN2*
-0120-2	285	550	190 000	690	Bussmann	170M5811	DIN2*
-0140-2	391	800	465 000	690	Bussmann	170M6812	DIN3
-0170-2	428	800	465 000	690	Bussmann	170M6812	DIN3
-0210-2	506	1000	945 000	690	Bussmann	170M6814	DIN3
-0230-2	599	1250	1 950 000	690	Bussmann	170M8554	DIN3
-0260-2	677	1600	3 900 000	690	Bussmann	170M8557	DIN3
-0300-2	707	1600	3 900 000	690	Bussmann	170M8557	DIN3
Three-phase supply voltage 380 V, <b>400 V</b> or 415 V							
-0140-3	196	400	105 000	690	Bussmann	170M3819	DIN1*
-0170-3	237	500	145 000	690	Bussmann	170M5810	DIN2*
-0210-3	286	550	190 000	690	Bussmann	170M5811	DIN2*
-0260-3	438	800	465 000	690	Bussmann	170M6812	DIN3
-0320-3	501	1000	945 000	690	Bussmann	170M6814	DIN3
-0400-3	581	1250	1 950 000	690	Bussmann	170M8554	DIN3
-0440-3	674	1600	3 900 000	690	Bussmann	170M8557	DIN3
-0490-3	705	1600	3 900 000	690	Bussmann	170M8557	DIN3
Three-phase supply voltage 380 V, 400 V, 415 V, 440 V, 460 V, 480 V or <b>500 V</b>							
-0170-5	191	400	105 000	690	Bussmann	170M3819	DIN1*
-0210-5	243	500	145 000	690	Bussmann	170M5810	DIN2*
-0260-5	291	550	190 000	690	Bussmann	170M5811	DIN2*
-0320-5	424	800	465 000	690	Bussmann	170M6812	DIN2*
-0400-5	498	1000	945 000	690	Bussmann	170M6814	DIN3
-0440-5	543	1250	1 950 000	690	Bussmann	170M8554	DIN3
-0490-5	590	1250	1 950 000	690	Bussmann	170M8554	DIN3
-0550-5	669	1600	3 900 000	690	Bussmann	170M8557	DIN3
-0610-5	702	1600	3 900 000	690	Bussmann	170M8557	DIN3
Three-phase supply voltage 525 V, 550 V, 575 V, 600 V, 660 V or <b>690 V</b>							
-0140-7	126	350	68 500	690	Bussmann	170M3818	DIN1*
-0170-7	156	350	68 500	690	Bussmann	170M3818	DIN1*
-0210-7	158/191*	400	74 000	690	Bussmann	170M5808	DIN2*
-0260-7	166/217*	400	74 000	690	Bussmann	170M5808	DIN2*
-0320-7	298	630	275 000	690	Bussmann	170M5812	DIN2*
-0400-7	333	630	210 000	690	Bussmann	170M6810	DIN3
-0440-7	377	800	465 000	690	Bussmann	170M6812	DIN3
-0490-7	423	900	670 000	690	Bussmann	170M6813	DIN3
-0550-7	468	900	670 000	690	Bussmann	170M6813	DIN3
-0610-7	533	1000	945 000	690	Bussmann	170M6814	DIN3

PDM code: 00096931-G

A<sup>2</sup>s value for -7 units at 660 V

\* output frequencies above 41 Hz

## Cable types

The table below gives copper and aluminium cable types for different load currents. Cable sizing is based on max. 9 cables laid on a cable ladder side by side, ambient temperature 30 °C, PVC insulation, surface temperature 70 °C (EN 60204-1 and IEC 60364-5-2/2001). For other conditions, size the cables according to local safety regulations, appropriate input voltage and the load current of the drive.

Copper cables with concentric copper shield		Aluminium cables with concentric copper shield	
Max. load current A	Cable type mm <sup>2</sup>	Max. load current A	Cable type mm <sup>2</sup>
62	3x16	61	3x25
79	3x25	75	3x35
98	3x35	91	3x50
119	3x50	117	3x70
153	3x70	143	3x95
186	3x95	165	3x120
215	3x120	191	3x150
249	3x150	218	3x185
284	3x185	257	3x240
335	3x240	274	3 x (3x50)
358	3 x (3x50)	285	2 x (3x95)
371	2 x (3x95)	331	2 x (3x120)
431	2 x (3x120)	351	3 x (3x70)
459	3 x (3x70)	382	2 x (3x150)
498	2 x (3x150)	428	3 x (3x95)
557	3 x (3x95)	437	2 x (3x185)
568	2 x (3x185)	496	3 x (3x120)
646	3 x (3x120)	515	2 x (3x240)
671	2 x (3x240)	573	3 x (3x150)
746	3 x (3x150)	655	3 x (3x185)
852	3 x (3x185)	772	3 x (3x240)
1006	3 x (3x240)		

PDM code: 00096931-C

## Cable entries

Mains, motor and brake resistor cable terminal sizes (per phase), maximum accepted cable and tightening torques are given below.

Frame size	U1, V1, W1, U2, V2, W2, UDC+/R+, UDC-, R-				Earthing PE	
	Number of holes per phase	Max. cable mm <sup>2</sup>	Screw	Tightening torque Nm	Screw	Tightening torque Nm
R7	3	1x240 or 2x185	M12	50...75	M10	30...44
R8	3	3x240	M12	50...75	M10	30...44



## Dimensions, weights and noise

Frame size	IP 00								Weight kg	Noise dB
	Busbars on the long side (bookshelf)				Busbars on the short side (flat)					
	H mm	W1 mm	W2 mm	D mm	H mm	W3 mm	W4 mm	D mm		
R7	1121	334	427	473	1181	525	631	259	100	71
R8	1564	415	562	568	1596	607	779	403	200	72

H height

W1 width of the basic unit with PE terminal (bookshelf)

W2 width with the cable connection terminal plates on the left side only (bookshelf)  
(R7: width with the cable connection terminal plates on both sides is 579 mm)  
(R8: width with the cable connection terminal plates on both sides is 776 mm)

D depth without fastening brackets  
(R7 bookshelf: depth with fastening brackets is 516 mm)  
(R8 bookshelf: depth with fastening brackets is 571 mm)

W3 width of the basic unit with PE terminal/busbar (flat)

W4 width with the cable connection terminal plates (flat)

Frame size	IP 00, with bottom exit			Weight * kg
	H mm	W mm	D mm	
R7	1126	264	471	91

H height without top and bottom exit busbar shrouds

W width

D depth

\* weight without top entry and bottom exit shrouds

## Input power connection

<b>Voltage (<math>U_1</math>)</b>	208/220/230/240 VAC 3-phase $\pm 10\%$ for 230 VAC units 380/400/415 VAC 3-phase $\pm 10\%$ for 400 VAC units 380/400/415/440/460/480/500 VAC 3-phase $\pm 10\%$ for 500 VAC units 525/550/575/600/660/690 VAC 3-phase $\pm 10\%$ for 690 VAC units
<b>Prospective short-circuit current (IEC 60439-1)</b>	65 kA (Icf)  US and Canada: The drive is suitable for use in a circuit capable of delivering not more than 65,000 symmetrical amperes (rms) at 600 V maximum.
<b>Frequency</b>	48 to 63 Hz, maximum rate of change 17 %/s
<b>Imbalance</b>	Max. $\pm 3\%$ of nominal phase to phase input voltage
<b>Fundamental power factor (<math>\cos \phi_1</math>)</b>	0.98 (at nominal load)

## Motor connection

**Voltage ( $U_2$ )** 0 to  $U_1$ , 3-phase symmetrical,  $U_{max}$  at the field weakening point  
**Frequency** DTC mode: 0 to  $3.2 \cdot f_{FWP}$ . Maximum frequency 300 Hz.

$$f_{FWP} = \frac{U_{Nmains}}{U_{Nmotor}} \cdot f_{Nmotor}$$

$f_{FWP}$ : frequency at field weakening point;  $U_{Nmains}$ : mains (input power) voltage;  
 $U_{Nmotor}$ : rated motor voltage;  $f_{Nmotor}$ : rated motor frequency

**Frequency resolution** 0.01 Hz

**Current** See section [IEC ratings](#).

**Power limit**  $1.5 \cdot P_{hd}$ ,  $1.1 \cdot P_N$  or  $P_{cont.max}$  (whichever value is greatest)

**Field weakening point** 8 to 300 Hz

**Switching frequency** 3 kHz (average). In 690 V units 2 kHz (average).

**Maximum recommended motor cable length**

Type code (EMC equipment)	Max. motor cable length	
	DTC control	Scalar control
-	300 m (984 ft)	300 m (984 ft)
+E202 *, +E210 *	100 m (328 ft)	100 m (328 ft)

\* Motor cable longer than 100 m (328 ft) is allowed but then the EMC Directive requirements may not be fulfilled.

## Efficiency

Approximately 98 % at nominal power level

## Cooling

**Method** Internal fan, flow direction from front to top

**Free space around the unit** Refer to *ACS800-04/04M/U4 Cabinet Installation* [68360323 (English)].

**Cooling air flow** See [IEC ratings](#).

## Degrees of protection

IP 00 (UL type: open chassis)

## Prevention of Unexpected Start: AGPS-21 board

**Nominal input voltage** 115 VAC or 230 VAC  
**Input voltage range (selected by jumper)** 95...132 VAC (X3 on), 185...265 VAC (X4 on, default)  
**Nominal frequency** 50/60 Hz  
**Current** 0.77 A at 115 V, 0.44 A at 230 V  
**Max. external fuse** 16 A  
**Input connector X1**  $3 \times 2.5 \text{ mm}^2$   
**User connector 1, 2, 3** 600 V, 25 A,  $0.5...4 \text{ mm}^2$  (20...12 AWG)  
**Output voltage**  $24 \text{ V} \pm 0.5 \text{ V}$   
**Nominal output current** 1.7 A (50 °C, 122 °F)  
**X2 terminal block type** JST B3P-VH  
**Ambient temperature** 0...50 °C (32...122 °F)  
**Relative humidity** 30...90 %, no condensation allowed  
**Approvals** CE, C-UL US listed

## Ambient conditions

Environmental limits for the drive are given below. The drive is to be used in a heated, indoor, controlled environment.

	<b>Operation</b> installed for stationary use	<b>Storage</b> in the protective package	<b>Transportation</b> in the protective package
<b>Installation site altitude</b>	0 to 4000 m (13123 ft) above sea level [above 1000 m (3281 ft), see section <i>Derating</i> ]	-	-
<b>Air temperature</b>	-15 to +50 °C (5 to 122 °F). See section <i>Derating</i> .	-40 to +70 °C (-40 to +158 °F)	-40 to +70 °C (-40 to +158 °F)
<b>Relative humidity</b>	5 to 95%	Max. 95%	Max. 95%
	No condensation allowed. Maximum allowed relative humidity is 60% in the presence of corrosive gases.		
<b>Contamination levels</b> (IEC 60721-3-3, IEC 60721-3-2, IEC 60721-3-1)	No conductive dust allowed.		
	<b>Boards without coating:</b> Chemical gases: Class 3C1 Solid particles: Class 3S2  <b>Boards with coating:</b> Chemical gases: Class 3C2 Solid particles: Class 3S2	<b>Boards without coating:</b> Chemical gases: Class 1C2 Solid particles: Class 1S3  <b>Boards with coating:</b> Chemical gases: Class 1C2 Solid particles: Class 1S3	<b>Boards without coating:</b> Chemical gases: Class 2C2 Solid particles: Class 2S2  <b>Boards with coating:</b> Chemical gases: Class 2C2 Solid particles: Class 2S2
<b>Atmospheric pressure</b>	70 to 106 kPa 0.7 to 1.05 atmospheres	70 to 106 kPa 0.7 to 1.05 atmospheres	60 to 106 kPa 0.6 to 1.05 atmospheres
<b>Vibration</b> (IEC 60068-2)	Max. 1 mm (0.04 in.) (5 to 13.2 Hz), max. 7 m/s <sup>2</sup> (23 ft/s <sup>2</sup> ) (13.2 to 100 Hz) sinusoidal	Max. 1 mm (0.04 in.) (5 to 13.2 Hz), max. 7 m/s <sup>2</sup> (23 ft/s <sup>2</sup> ) (13.2 to 100 Hz) sinusoidal	Max. 3.5 mm (0.14 in.) (2 to 9 Hz), max. 15 m/s <sup>2</sup> (49 ft/s <sup>2</sup> ) (9 to 200 Hz) sinusoidal
<b>Shock</b> (IEC 60068-2-29)	Not allowed	Max. 100 m/s <sup>2</sup> (330 ft./s <sup>2</sup> ), 11 ms	Max. 100 m/s <sup>2</sup> (330 ft./s <sup>2</sup> ), 11 ms
<b>Free fall</b>	Not allowed	100 mm (4 in.) for weight over 100 kg (220 lb)	100 mm (4 in.) for weight over 100 kg (220 lb)

## Materials

---

<b>Drive enclosure</b>	<ul style="list-style-type: none"> <li>• PC/ABS 2.5 mm, colour NCS 1502-Y (RAL 90021 / PMS 420 C)</li> <li>• hot-dip zinc coated steel sheet 1.5 to 2.5 mm, thickness of coating 100 micrometres, colour NCS 1502-Y</li> </ul>
<b>Package</b>	Plywood and wood. Plastic covering of the package: PE-LD, bands PP or steel.
<b>Disposal</b>	<p>The drive contains raw materials that should be recycled to preserve energy and natural resources. The package materials are environmentally compatible and recyclable. All metal parts can be recycled. The plastic parts can either be recycled or burned under controlled circumstances, according to local regulations. Most recyclable parts are marked with recycling marks.</p> <p>If recycling is not feasible, all parts excluding electrolytic capacitors and printed circuit boards can be landfilled. The DC capacitors (C1-1 to C1-x) contain electrolyte and the printed circuit boards contain lead, both of which will be classified as hazardous waste within the EU. They must be removed and handled according to local regulations.</p> <p>For further information on environmental aspects and more detailed recycling instructions, please contact your local ABB distributor.</p>

## Applicable standards

---

	The drive complies with the following standards. The compliance with the European Low Voltage Directive is verified according to standards EN 50178 and EN 60204-1.
• EN 50178 (1997)	Electronic equipment for use in power installations
• EN 60204-1 (1997)	<p>Safety of machinery. Electrical equipment of machines. Part 1: General requirements.</p> <p><i>Provisions for compliance:</i> The final assembler of the machine is responsible for installing</p> <ul style="list-style-type: none"> <li>- an emergency-stop device</li> <li>- a supply disconnecting device</li> <li>- the ACS800-04/04M/U4 into a cabinet.</li> </ul>
• EN 60529: 1991 (IEC 529)	Degrees of protection provided by enclosures (IP code)
• IEC 60664-1 (1992)	Insulation coordination for equipment within low-voltage systems. Part 1: Principles, requirements and tests.
• EN 61800-3 (1996) + Amendment A11 (2000)	EMC product standard including specific test methods
• UL 508C	UL Standard for Safety, Power Conversion Equipment, second edition
• CSA C22.2 No. 14-95	Industrial control equipment

## CE marking

A CE mark is attached to the drive to verify that the unit follows the provisions of the European Low Voltage and EMC Directives (Directive 73/23/EEC, as amended by 93/68/EEC and Directive 89/336/EEC, as amended by 93/68/EEC).

### Definitions

EMC stands for **E**lectromagnetic **C**ompatibility. It is the ability of electrical/electronic equipment to operate without problems within an electromagnetic environment. Likewise, the equipment must not disturb or interfere with any other product or system within its locality.

*First environment* includes establishments connected to a low-voltage network which supplies buildings used for domestic purposes.

*Second environment* includes establishments connected to a network not supplying domestic premises.

*Restricted distribution*: mode of sales distribution in which the manufacturer restricts the supply of equipment to suppliers, customers or users who separately or jointly have technical competence in the EMC requirements of the application of drives.

*Unrestricted distribution*: mode of sales distribution in which the supply of equipment is not dependent on the EMC competence of the customer or user for the application of drives.

### Compliance with the EMC Directive

The EMC Directive defines the requirements for immunity and emissions of electrical equipment used within the European Union. The EMC product standard [EN 61800-3 + Amendment A11 (2000)] covers requirements stated for drives.

### Compliance with the EN 61800-3 + Amendment A11 (2000)

#### *First environment (restricted distribution)*

The requirements of the EMC Directive can be met as follows for restricted distribution:

1. The drive is equipped with EMC filter +E202.
2. The motor and control cables are selected as specified in the *Hardware Manual*.
3. The drive is installed according to the instructions given in the *Hardware Manual*.
4. Maximum cable length is 100 metres.

**WARNING!** The drive may cause radio interference if used in a residential or domestic environment. The user is required to take measures to prevent interference, in addition to the requirements for CE compliance listed above, if necessary.

**Note:** It is not allowed to install a drive equipped with the EMC filter +E202 on IT (unearthed) systems. The supply network becomes connected to earth potential through the EMC filter capacitors which may cause danger or damage the unit.

## Second environment

The drive complies with the standard with the following provisions:

1. The drive is equipped with EMC filter +E210. The filter is suitable for TN (earthed) and IT (unearthed) networks.
2. The motor and control cables are selected as specified in the *Hardware Manual*.
3. The drive is installed according to the instructions given in the *Hardware Manual*.
4. Maximum cable length is 100 metres.

If the above listed provisions cannot be met, the requirements of the EMC Directive can be met as follows for restricted distribution:

1. It is ensured that no excessive emission is propagated to neighbouring low-voltage networks. In some cases, the natural suppression in transformers and cables is sufficient. If in doubt, the supply transformer with static screening between the primary and secondary windings can be used.

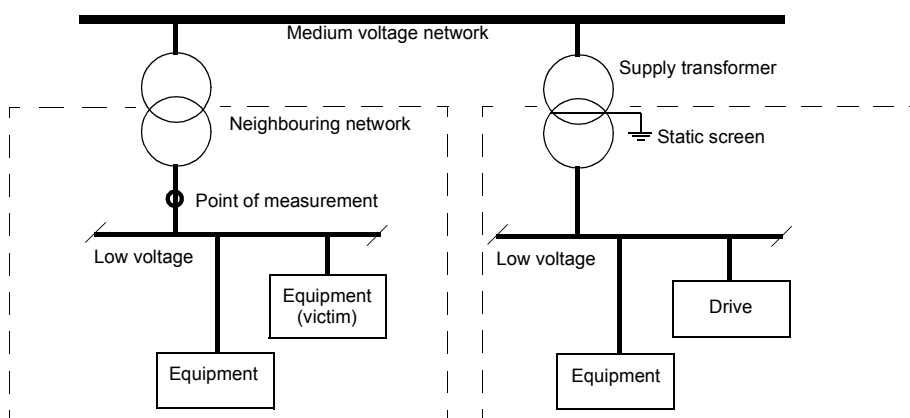

2. An EMC plan for preventing disturbances is drawn up for the installation. A template is available from the local ABB representative.
3. The motor and control cables are selected as specified in the *Hardware Manual*.
4. The drive is installed according to the instructions given in the *Hardware Manual*.

## Machinery Directive

The drive complies with the European Union Machinery Directive (98/37/EC) requirements for an equipment intended to be incorporated into machinery.

## “C-tick” marking

“C-tick” marking is required in Australia and New Zealand. A “C-tick” mark is attached to each drive in order to verify compliance with the relevant standard (IEC 61800-3 (1996) – Adjustable speed electrical power drive systems – Part 3: EMC product standard including specific test methods), mandated by the Trans-Tasman Electromagnetic Compatibility Scheme.

### Definitions

EMC stands for **E**lectromagnetic **C**ompatibility. It is the ability of electrical/electronic equipment to operate without problems within an electromagnetic environment. Likewise, the equipment must not disturb or interfere with any other product or system within its locality.

The Trans-Tasman Electromagnetic Compatibility Scheme (EMCS) was introduced by the Australian Communication Authority (ACA) and the Radio Spectrum Management Group (RSM) of the New Zealand Ministry of Economic Development (NZMED) in November 2001. The aim of the scheme is to protect the radiofrequency spectrum by introducing technical limits for emission from electrical/ electronic products.

*First environment* includes establishments connected to a low-voltage network which supplies buildings used for domestic purposes.

*Second environment* includes establishments connected to a network not supplying domestic premises.

*Restricted distribution*: mode of sales distribution in which the manufacturer restricts the supply of equipment to suppliers, customers or users who separately or jointly have technical competence in the EMC requirements of the application of drives.

*Unrestricted distribution*: mode of sales distribution in which the supply of equipment is not dependent on the EMC competence of the customer or user for the application of drives.

### Compliance with IEC 61800-3

#### *First environment (restricted distribution)*

The drive complies with the limits of IEC 61800-3 with the following provisions:

1. The drive is equipped with EMC filter +E202.
2. The drive is installed according to the instructions given in the *Hardware Manual*.
3. The motor and control cables used are selected as specified in the *Hardware Manual*.
4. Maximum cable length is 100 metres.

**Note:** The drive must not be equipped with the EMC filter +E202 when installed to IT (unearthed) systems. The mains becomes connected to earth potential through the EMC filter capacitors. In IT systems this may cause danger or damage the unit.

### Second environment

The drive complies with the limits of IEC 61800-3 with the following provisions:

1. It is ensured that no excessive emission is propagated to neighbouring low-voltage networks. In some cases, the natural suppression in transformers and cables is sufficient. If in doubt, the supply transformer with static screening between the primary and secondary windings is strongly recommended.

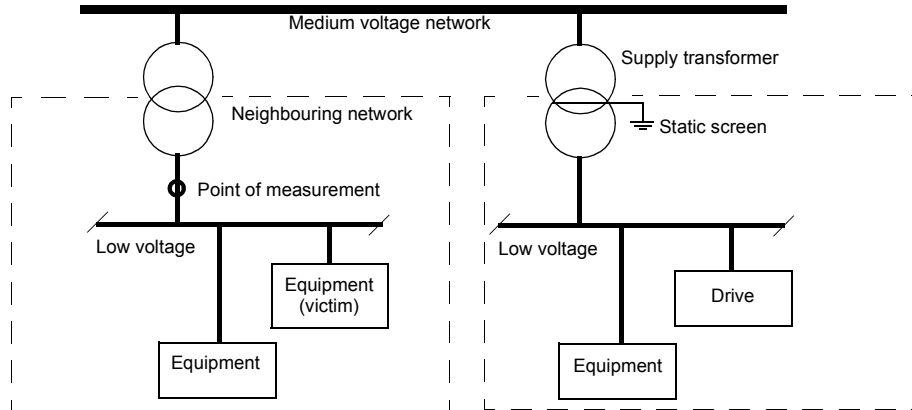

2. The drive is installed according to the instructions given in the *Hardware Manual*.
3. The motor and control cables used are selected as specified in the *Hardware Manual*.

## Equipment warranty and liability

The manufacturer warrants the equipment supplied against defects in design, materials and workmanship for a period of twelve (12) months after installation or twenty-four (24) months from date of manufacturing, whichever first occurs. The local ABB office or distributor may grant a warranty period different to the above and refer to local terms of liability as defined in the supply contract.

The manufacturer is not responsible for

- any costs resulting from a failure if the installation, commissioning, repair, alternation, or ambient conditions of the drive do not fulfil the requirements specified in the documentation delivered with the unit and other relevant documentation.
- units subjected to misuse, negligence or accident
- units comprised of materials provided or designs stipulated by the purchaser.

In no event shall the manufacturer, its suppliers or subcontractors be liable for special, indirect, incidental or consequential damages, losses or penalties.

This is the sole and exclusive warranty given by the manufacturer with respect to the equipment and is in lieu of and excludes all other warranties, express or implied, arising by operation of law or otherwise, including, but not limited to, any implied warranties of merchantability or fitness for a particular purpose.

If you have any questions concerning your ABB drive, please contact the local distributor or ABB office. The technical data, information and specifications are valid at the time of printing. The manufacturer reserves the right to modifications without prior notice.



## US tables

### NEMA ratings

The NEMA ratings for the ACS800-U4 and ACS800-04 with 60 Hz supplies are given below. The symbols are described below the table. For sizing, derating and 50 Hz supplies, see [IEC ratings](#).

ACS800-U4 size ACS800-04 size	$I_{max}$ A	Normal use		Heavy-duty use		Frame size	Air flow ft <sup>3</sup> /min	Heat dissipation BTU/Hr
		$I_{2N}$ A	$P_N$ HP	$I_{2hd}$ A	$P_{hd}$ HP			
Three-phase supply voltage 208 V, 220 V, <b>230 V</b> , 240 V								
-0080-2	326	211	75	170	60	R7	318	9900
-0100-2	404	248	100	202	75	R7	318	11750
-0120-2	432	290	100	240 <sup>4)</sup>	75	R7	318	13750
-0140-2	588	396	150	316	125	R8	718	18100
-0170-2	588	440	150	340	125	R8	718	20800
-0210-2	588	516	200	370	150	R8	718	22750
-0230-2	840	598	200	480	200	R8	718	25900
-0260-2	1017	679	250	590 <sup>3)</sup>	200	R8	718	26750
-0300-2	1017	704	250	635 <sup>3)</sup>	250	R8	718	28300
Three-phase supply voltage 380 V, 400 V, 415 V, 440 V, <b>460 V</b> , 480 V								
-0170-5	326	192	150	162	125	R7	318	10100
-0210-5	384	240	200	192	150	R7	318	12900
-0260-5	432	289 <sup>1)</sup>	250 <sup>2)</sup>	224	150	R7	318	15300
-0270-5 **	480	316	250	240	200	R8	718	15350
-0300-5 **	568	361	300	302	250	R8	718	18050
-0320-5	588	435	350	340	250	R8	718	23250
-0400-5	588	510	400	370	300	R8	718	26650
-0440-5	840	545	450	490	400	R8	718	25950
-0490-5	840	590	500	515 <sup>3)</sup>	450	R8	718	27600
-0550-5	1017	670	550	590 <sup>3)</sup>	500	R8	718	31100
-0610-5	1017	718 <sup>4)</sup>	600	590 <sup>3)</sup>	500	R8	718	33000
Three-phase supply voltage 525 V, <b>575 V</b> or 600 V								
-0140-7	190	125	125	95	100 <sup>2)</sup>	R7	318	9600
-0170-7	263	155	150	131	125	R7	318	12150
-0210-7	294	165/195*	150/200*	147	150	R7	318	14550
-0260-7	326	175/212*	150/200*	163	150	R7	318	16400
-0320-7	433	290	300	216	200	R8	718	21050
-0400-7	548	344	350	274	250	R8	718	22750
-0440-7	656	387	400	328	350 <sup>2)</sup>	R8	718	25300
-0490-7	775	426	450	387	400	R8	718	28900
-0550-7	853	482	500	426	450	R8	718	28350
-0610-7	964	537	500	482	500	R8	718	33300

PDM code: 00096931-G

- 1) available if ambient temperature is less than 30 °C (86 °F). If ambient temperature is 40 °C (104 °F),  $I_{2N}$  is 286 A.
- 2) special 4-pole high-efficiency NEMA motor

- 3) 50 % overload is allowed for one minute every five minutes if ambient temperature is less than 30 °C (86 °F). 40 % overload is allowed if ambient temperature is 40 °C (104 °F).
- 4) available if ambient temperature is less than 30 °C (86 °F). If ambient temperature is 40 °C (104 °F),  $I_{2N}$  is 704 A.
- \* higher value available if output frequency is above 41 Hz
- \*\* ACS800-U4 types only

## Symbols

$I_{max}$  maximum output current. Available for 10 s at start, otherwise as long as allowed by drive temperature.

### Normal use (10 % overload capability)

$I_{2N}$  continuous rms current. 10 % overload is typically allowed for one minute every 5 minutes.

$P_N$  typical motor power. The power ratings apply to most 4-pole NEMA rated motors (230 V, 460 V or 575 V).

### Heavy-duty use (50 % overload capability)

$I_{2hd}$  continuous rms current. 50 % overload is typically allowed for one minute every 5 minutes.

$P_{hd}$  typical motor power. The power ratings apply to most 4-pole NEMA rated motors (230 V, 460 V or 575 V).

**Note:** The ratings apply at ambient temperature of 40 °C (104 °F). At lower temperatures the ratings are higher.

## Input cable fuses

The recommended fuses are for branch circuit protection per NEC. The fuses restrict drive damage and prevent damage to adjoining equipment in case of a short-circuit inside the drive. **Check that the operating time of the fuse is below 0.5 seconds and the fuses are of the “non-time delay” type**. The operating time depends on the fuse type (T/L or aR), supply network impedance and the cross-sectional area, material and length of the supply cable. In case the 0.5 seconds operating time is exceeded with T/L fuses, ultrarapid (aR) fuses will in most cases reduce the operating time to an acceptable level. The fuses must be of the “non-time delay” type. See also *Planning the electrical installation / [Thermal overload and short-circuit protection](#)*.

**Note 1:** In multicable installations, install only one fuse per phase (not one fuse per conductor).

**Note 2:** Larger fuses must not be used.

**Note 3:** Fuses from other manufacturers can be used if they meet the ratings.

ACS800-U4 type	Input current A	Fuse				
		A	V	Manufacturer	Type	UL class
Three-phase supply voltage 208 V, 220 V, <b>230 V</b> , 240 V						
-0080-2	201	250	600	Bussmann	JJS-250	T
-0100-2	239	300	600	Bussmann	JJS-300	T
-0120-2	285	400	600	Bussmann	JJS-400	T
-0140-2	391	500	600	Bussmann	JJS-500	T
-0170-2	428	600	600	Bussmann	JJS-600	T
-0210-2	506	600	600	Bussmann	JJS-600	T
-0230-2	599	800	600	Bussmann	KTU-800 <sup>1)</sup>	L
-0260-2	677	800	600	Bussmann	KTU-800 <sup>1)</sup>	L
-0300-2	707	800	600	Bussmann	KTU-900	L
Three-phase supply voltage 380 V, 400 V, 415 V, 440 V, <b>460 V</b> , 480 V or 500 V						
-0170-5	175	250	600	Bussmann	JJS-250	T
-0210-5	220	300	600	Bussmann	JJS-300	T
-0260-5	267	400	600	Bussmann	JJS-400	T
-0270-5	293	500	600	Bussmann	JJS-500	T
-0300-5	331	500	600	Bussmann	JJS-500	T
-0320-5	397	500	600	Bussmann	JJS-500	T
-0400-5	467	600	600	Bussmann	JJS-600	T
-0440-5	501	800	600	Bussmann	KTU-800 <sup>1)</sup>	L
-0490-5	542	800	600	Bussmann	KTU-800 <sup>1)</sup>	L
-0550-5	614	800	600	Bussmann	KTU-900	L
-0610-5	661	800	600	Bussmann	KTU-900	L
Three-phase supply voltage 525 V, <b>575 V</b> or 600 V						
-0140-7	117	200	600	Bussmann	JJS-200	T
-0170-7	146	200	600	Bussmann	JJS-200	T
-0210-7	184	250	600	Bussmann	JJS-250	T
-0260-7	199	300	600	Bussmann	JJS-300	T
-0320-7	273	500	600	Bussmann	JJS-500	T
-0400-7	325	500	600	Bussmann	JJS-500	T
-0440-7	370	500	600	Bussmann	JJS-500	T
-0490-7	407	600	600	Bussmann	JJS-600	T
-0550-7	463	600	600	Bussmann	JJS-600	T
-0610-7	513	700	600	Bussmann	KTU-700 <sup>1)</sup>	L

PDM code: 00096931-G

<sup>1)</sup> also 800 A class T fuse JJS-800 can be used

*Ultrarapid (aR) fuses*

ACS800-U4 size	Input current A	Fuse					
		A	A <sup>2</sup> s	V	Manufacturer	Type DIN 43653/110 	Size
Three-phase supply voltage 208 V, 220 V, <b>230 V</b> , 240 V							
-0080-2	201	400	105 000	690	Bussmann	170M3169	1*
-0100-2	239	500	145 000	690	Bussmann	170M5160	2
-0120-2	285	550	190 000	690	Bussmann	170M5161	2
-0140-2	391	800	465 000	690	Bussmann	170M6162	3
-0170-2	428	800	465 000	690	Bussmann	170M6162	3
-0210-2	506	1000	945 000	690	Bussmann	170M6164	3
-0230-2	599	1250	1 950 000	690	Bussmann	170M6166	3
-0260-2	677	1600	3 900 000	690	Bussmann	170M6169	3
-0300-2	707	1600	3 900 000	690	Bussmann	170M6169	3
Three-phase supply voltage 380 V, 400 V, 415 V, 440 V, <b>460 V</b> , 480 V or 500 V							
-0170-5	175	400	105 000	690	Bussmann	170M3169	1*
-0210-5	220	500	145 000	690	Bussmann	170M5160	2
-0260-5	267	550	190 000	690	Bussmann	170M5161	2
-0270-5	293	800	465 000	690	Bussmann	170M6162	3
-0300-5	331	800	465 000	690	Bussmann	170M6162	3
-0320-5	397	800	465 000	690	Bussmann	170M6162	3
-0400-5	467	1000	945 000	690	Bussmann	170M6164	3
-0440-5	501	1250	1 950 000	690	Bussmann	170M6166	3
-0490-5	542	1250	1 950 000	690	Bussmann	170M6166	3
-0550-5	614	1600	3 900 000	690	Bussmann	170M6169	3
-0610-5	661	1600	3 900 000	690	Bussmann	170M6169	3
Three-phase supply voltage 525 V, <b>575 V</b> or 600 V							
-0140-7	117	350	68 500	690	Bussmann	170M3168	1*
-0170-7	146	350	68 500	690	Bussmann	170M3168	1*
-0210-7	184	400	74 000	690	Bussmann	170M5158	2
-0260-7	199	400	74 000	690	Bussmann	170M5158	2
-0320-7	273	630	275 000	690	Bussmann	170M5162	2
-0400-7	325	630	275 000	690	Bussmann	170M6160	3
-0440-7	370	800	465 000	690	Bussmann	170M6162	3
-0490-7	407	900	670 000	690	Bussmann	170M6163	3
-0550-7	463	900	670 000	690	Bussmann	170M6163	3
-0610-7	513	1000	945 000	690	Bussmann	170M6164	3

PDM code: 00096931-G

## Cable types

Cable sizing is based on NEC Table 310-16 for copper wires, 75 °C (167 °F) wire insulation at 40 °C (104 °F) ambient temperature. Not more than three current-carrying conductors in raceway or cable or earth (directly buried). For other conditions, dimension the cables according to local safety regulations, appropriate input voltage and the load current of the drive.

<b>Copper cables with concentric copper shield</b>	
<b>Max. load current</b> A	<b>Cable type</b> AWG/kcmil
57	6
75	4
88	3
101	2
114	1
132	1/0
154	2/0
176	3/0
202	4/0
224	250 MCM or 2 x 1
251	300 MCM or 2 x 1/0
273	350 MCM or 2 x 2/0
295	400 MCM or 2 x 2/0
334	500 MCM or 2 x 3/0
370	600 MCM or 2 x 4/0 or 3 x 1/0
405	700 MCM or 2 x 4/0 or 3 x 2/0
449	2 x 250 MCM or 3 x 2/0
502	2 x 300 MCM or 3 x 3/0
546	2 x 350 MCM or 3 x 4/0
590	2 x 400 MCM or 3 x 4/0
669	2 x 500 MCM or 3 x 250 MCM
739	2 x 600 MCM or 3 x 300 MCM
810	2 x 700 MCM or 3 x 350 MCM
884	3 x 400 MCM or 4 x 250 MCM
1003	3 x 500 MCM or 4 x 300 MCM
1109	3 x 600 MCM or 4 x 400 MCM
1214	3 x 700 MCM or 4 x 500 MCM

## Cable Entries

Input, motor and brake resistor cable terminal sizes (per phase) and tightening torques are given below. Two-hole 1/2 inch diameter cable lugs can be used.

<b>Frame size</b>	<b>Max. cable</b> kcmil/AWG	<b>U1, V1, W1, U2, V2, W2, UDC+/R+, UDC-, R-</b>				<b>Earthing PE</b>	
		<b>Screw</b>	<b>Tightening torque</b> lbf ft	<b>Screw</b>	<b>Tightening torque</b> lbf ft		
R7	2x250 MCM	1/2	37...55	3/8	22...32		
R8	3x700 MCM	1/2	37...55	3/8	22...32		

## Dimensions and weights

Frame size	UL type: open chassis				Weight lb
	Height in.	W1 in.	W2 in.	Depth in.	
R7	44.13	13.15	16.36	18.31	220
R8	61.57	16.35	22.14	22.36	441

H height

W1 width of the basic unit with PE terminal (bookshelf)

W2 width with the cable connection terminal plates on the left side only (bookshelf)

D depth without fastening brackets  
 (R7 bookshelf: depth with fastening brackets is 20.32 in.)  
 (R8 bookshelf: depth with fastening brackets is 22.48 mm)

## UL/CSA markings

The ACS800-04, ACS800-U4 and ACS800-04M are C-UL US listed and CSA marked. The approval is valid with rated voltages (up to 600 V).

### UL

The drive is suitable for use on a circuit capable of delivering not more than 65 kA rms symmetrical amperes at the drive nominal voltage (600 V maximum for 690 V units).

The drive provides overload protection in accordance with the National Electrical Code (US). See *ACS800 Firmware Manual* for setting. Default setting is off, must be activated at start-up.

The drives are to be used in a heated indoor controlled environment. See section [Ambient conditions](#) for specific limits.

Brake chopper - ABB has brake choppers that, when applied with appropriately sized brake resistors, will allow the drive to dissipate regenerative energy (normally associated with quickly decelerating a motor). Proper application of the brake chopper is defined in chapter [Resistor braking](#). This can be applied to a single drive or multiple drives with DC bus connected to allow a sharing of regenerative energy.

# Resistor braking

---

## What this chapter contains

This chapter describes how to select, protect and wire brake choppers and resistors. The chapter also contains the technical data.

## To which products this chapter applies

This chapter applies to the ACS800-01/U1 (frame sizes R2 to R6), ACS800-02/U2 (frame sizes R7 and R8), ACS800-04/U4 (frame sizes R7 and R8) and ACS800-07/U7 (frame sizes R6, R7 and R8).

## Availability of brake choppers and resistors for the ACS800

Frame R2 and R3 drives have a built-in brake chopper as standard equipment. For frames R4 and up, brake choppers are optionally available as built-in units, indicated in the type code by +D150.

Resistors are available as add-on kits. For the ACS800-07/U7, resistors are available as factory installed.

## How to select the correct drive/chopper/resistor combination

1. Calculate the maximum power ( $P_{\max}$ ) generated by the motor during braking.
2. Select a suitable drive / brake chopper / brake resistor combination for the application according to the following tables (take account of other factors in the drive selection also). The following condition must be met:

$$P_{\text{br}} \geq P_{\max}$$

where

$P_{\text{br}}$  denotes  $P_{\text{br}5}$ ,  $P_{\text{br}10}$ ,  $P_{\text{br}30}$ ,  $P_{\text{br}60}$ , or  $P_{\text{brcont}}$  depending on the duty cycle.

3. Check the resistor selection. The energy generated by the motor during a 400-second period must not exceed the resistor heat dissipation capacity  $E_R$ .

If the  $E_R$  value is not sufficient, it is possible to use a four-resistor assembly in which two standard resistors are connected in parallel, two in series. The  $E_R$  value of the four-resistor assembly is four times the value specified for the standard resistor.

**Note:** A resistor other than the standard resistor can be used provided that:

- its resistance is not lower than the resistance of the standard resistor.



**WARNING!** Never use a brake resistor with a resistance below the value specified for the particular drive / brake chopper / resistor combination. The drive and the chopper are not able to handle the overcurrent caused by the low resistance.

- the resistance does not restrict the braking capacity needed, i.e.,

$$P_{\max} < \frac{U_{\text{DC}}^2}{R}$$

where

$P_{\max}$  maximum power generated by the motor during braking

$U_{\text{DC}}$  voltage over the resistor during braking, e.g.,

1.35 · 1.2 · 415 VDC (when supply voltage is 380 to 415 VAC),

1.35 · 1.2 · 500 VDC. (when supply voltage is 440 to 500 VAC) or

1.35 · 1.2 · 690 VDC (when supply voltage is 525 to 690 VAC).

R resistor resistance (ohm)

- the heat dissipation capacity ( $E_R$ ) is sufficient for the application (see step 3 above).

## Optional brake chopper and resistor(s) for the ACS800-01/U1

The nominal ratings for dimensioning the brake resistors for the ACS800-01 and ACS800-U1 are given below at an ambient temperature of 40 °C (104 °F).

ACS 800-01 type ACS 800-U1 type	Braking power of the chopper and the drive	Brake resistor(s)			
	$P_{\text{brcont}}$ (kW)	Type	R (ohm)	$E_R$ (kJ)	$P_{\text{Rcont}}$ (kW)
230 V units					
-0001-2	0.55	SACE08RE44	44	248	1
-0002-2	0.8	SACE08RE44	44	248	1
-0003-2	1.1	SACE08RE44	44	248	1
-0004-2	1.5	SACE08RE44	44	248	1
-0005-2	2.2	SACE15RE22	22	497	2
-0006-2	3.0	SACE15RE22	22	497	2
-0009-2	4.0	SACE15RE22	22	497	2
-0011-2	5.5	SACE15RE13	13	497	2
-0016-2	11	SAFUR90F575	8	1800	4.5
-0020-2	17	SAFUR90F575	8	1800	4.5
-0025-2	23	SAFUR80F500	6	2400	6
-0030-2	28	SAFUR125F500	4	3600	9
-0040-2	33	SAFUR125F500	4	3600	9
-0050-2	45	2xSAFUR125F500	2	7200	18
-0060-2	56	2xSAFUR125F500	2	7200	18
-0070-2	68	2xSAFUR125F500	2	7200	18



ACS 800-01 type ACS 800-U1 type	Braking power of the chopper and the drive $P_{brcont}$ (kW)	Brake resistor(s)			
		Type	$R$ (ohm)	$E_R$ (kJ)	$P_{Rcont}$ (kW)
400 V units					
-0003-3	1.1	SACE08RE44	44	210	1
-0004-3	1.5	SACE08RE44	44	210	1
-0005-3	2.2	SACE08RE44	44	210	1
-0006-3	3.0	SACE08RE44	44	210	1
-0009-3	4.0	SACE08RE44	44	210	1
-0011-3	5.5	SACE15RE22	22	420	2
-0016-3	7.5	SACE15RE22	22	420	2
-0020-3	11	SACE15RE22	22	420	2
-0025-3	23	SACE15RE13	13	435	2
-0030-3	28	SACE15RE13	13	435	2
-0040-3	33	SAFUR90F575	8	1800	4.5
-0050-3	45	SAFUR90F575	8	1800	4.5
-0060-3	56	SAFUR90F575	8	1800	4.5
-0070-3	68	SAFUR80F500	6	2400	6
-0100-3	83	SAFUR125F500	4	3600	9
-0120-3	113	SAFUR125F500	4	3600	9
500 V units					
-0004-5	1.5	SACE08RE44	44	210	1
-0005-5	2.2	SACE08RE44	44	210	1
-0006-5	3.0	SACE08RE44	44	210	1
-0009-5	4.0	SACE08RE44	44	210	1
-0011-5	5.5	SACE08RE44	44	210	1
-0016-5	7.5	SACE15RE22	22	420	2
-0020-5	11	SACE15RE22	22	420	2
-0025-5	15	SACE15RE22	22	420	2
-0030-5	28	SACE15RE13	13	435	2
-0040-5	33	SACE15RE13	13	435	2
-0050-5	45	SAFUR90F575	8	1800	4.5
-0060-5	56	SAFUR90F575	8	1800	4.5
-0070-5	68	SAFUR90F575	8	1800	4.5
-0100-5	83	SAFUR125F500	4	3600	9
-0120-5	113	SAFUR125F500	4	3600	9
-0140-5	135	SAFUR125F500	4	3600	9
690 V units					
-0011-7	8.0	SACE08RE44	44	248	1
-0016-7	11.0	SACE08RE44	44	248	1
-0020-7	16	SACE08RE44	44	248	1
-0025-7	22	SACE08RE44	44	248	1
-0030-7	28.0	SACE15RE22	22	497	2
-0040-7	33	SACE15RE22	22	497	2
-0050-7	45	SAFUR90F575	8	1800	4.5
-0060-7	56	SAFUR90F575	8	1800	4.5
-0070-7	68	SAFUR90F575	8	1800	4.5
-0100-7	83	SAFUR80F500	6	2400	6
-0120-7	113	SAFUR80F500	6	2400	6

PDM code 00096931-G

$P_{brcont}$  The drive and the chopper will withstand this continuous braking power. The braking is considered continuous if the braking time exceeds 30 s.

**Note: Check that the braking energy transmitted to the specified resistor(s) in 400 seconds does not exceed  $E_R$ .**

$R$  Resistance value for the listed resistor assembly. **Note:** This is also the minimum allowed resistance for the brake resistor.

$E_R$  Short energy pulse that the resistor assembly withstands every 400 seconds. This energy will heat the resistor element from 40 °C (104 °F) to the maximum allowable temperature.

$P_{Rcont}$  Continuous power (heat) dissipation of the resistor when placed correctly. Energy  $E_R$  dissipates in 400 seconds.

All braking resistors must be installed outside the converter module. The SACE brake resistors are built in an IP 21 metal housing. The SAFUR brake resistors are built in an IP 00 metal frame. **Note:** The SACE and SAFUR resistors are not UL listed.

## Optional brake chopper and resistor(s) for the ACS800-02/U2, ACS800-04/04M/U4 and ACS800-07/U7

The nominal ratings for dimensioning the brake resistors for the ACS800-02/U2, ACS800-04/04M/U4 and ACS800-07/U7 are given below at an ambient temperature of 40 °C (104 °F).

ACS 800 type	Frame size	Braking power of the chopper and the drive				Brake resistor(s)			
		5/60 s $P_{br5}$ (kW)	10/60 s $P_{br10}$ (kW)	30/60 s $P_{br30}$ (kW)	$P_{brcont}$ (kW)	Type	R (ohm)	$E_R$ (kJ)	$P_{Rcont}$ (kW)
230 V units									
-0080-2	R7	68	68	68	54	SAFUR160F380	1.78	3600	9
-0100-2	R7	83	83	83	54	SAFUR160F380	1.78	3600	9
-0120-2	R7	105	67	60	40	2xSAFUR200F500	1.35	10800	27
-0140-2	R8	135	135	135	84	2xSAFUR160F380	0.89	7200	18
-0170-2	R8	135	135	135	84	2xSAFUR160F380	0.89	7200	18
-0210-2	R8	165	165	165	98	2xSAFUR160F380	0.89	7200	18
-0230-2	R8	165	165	165	113	2xSAFUR160F380	0.89	7200	18
-0260-2	R8	223	170	125	64	4xSAFUR160F380	0.45	14400	36
-0300-2	R8	223	170	125	64	4xSAFUR160F380	0.45	14400	36
400 V units									
-0070-3	R6	-	-	-	68	SAFUR80F500	6	2400	6
-0100-3	R6	-	-	-	83	SAFUR125F500	4	3600	9
-0120-3	R6	-	-	-	113	SAFUR125F500	4	3600	9
-0140-3	R7	135	135	100	80	SAFUR200F500	2.70	5400	13.5
-0170-3	R7	165	150	100	80	SAFUR200F500	2.70	5400	13.5
-0210-3	R7	165	150	100	80	SAFUR200F500	2.70	5400	13.5
-0260-3	R8	240	240	240	173	2XSAFUR210F575	1.70	8400	21
-0320-3	R8	300	300	300	143	2xSAFUR200F500	1.35	10800	27
-0400-3	R8	375	375	273	130	4xSAFUR125F500	1.00	14400	36
-0440-3	R8	473	355	237	120	4xSAFUR210F575	0.85	16800	42
-0490-3	R8	500	355	237	120	4xSAFUR210F575	0.85	16800	42
500 V units									
-0100-5	R6	-	-	-	83	SAFUR125F500	4	3600	9
-0120-5	R6	-	-	-	113	SAFUR125F500	4	3600	9
-0140-5	R6	-	-	-	135	SAFUR125F500	4	3600	9
-0170-5	R7	165	132 <sup>2)</sup>	120	80	SAFUR200F500	2.70	5400	13.5
-0210-5	R7	198	132 <sup>2)</sup>	120	80	SAFUR200F500	2.70	5400	13.5
-0260-5	R7	198 <sup>1)</sup>	132 <sup>2)</sup>	120	80	SAFUR200F500	2.70	5400	13.5
-0270-5*	R8	240	240	240	240	2xSAFUR125F500	2.00	7200	18
-0300-5*	R8	280	280	280	280	2xSAFUR125F500	2.00	7200	18
-0320-5	R8	300	300	300	300	2xSAFUR125F500	2.00	7200	18
-0400-5	R8	375	375	375	234	2XSAFUR210F575	1.70	8400	21
-0440-5	R8	473	473	450	195	2xSAFUR200F500	1.35	10800	27
-0490-5	R8	480	480	470	210	2xSAFUR200F500	1.35	10800	27
-0550-5	R8	600	400 <sup>4)</sup>	300	170	4xSAFUR125F500	1.00	14400	36
-0610-5	R8	600 <sup>3)</sup>	400 <sup>4)</sup>	300	170	4xSAFUR125F500	1.00	14400	36

ACS 800 type	Frame size	Braking power of the chopper and the drive				Brake resistor(s)			
		5/60 s $P_{br5}$ (kW)	10/60 s $P_{br10}$ (kW)	30/60 s $P_{br30}$ (kW)	$P_{brcont}$ (kW)	Type	R (ohm)	$E_R$ (kJ)	$P_{Rcont}$ (kW)
690 V units									
-0070-7	R6	-	-	-	45	SAFUR90F575	8.00	1800	4.5
-0100-7	R6	-	-	-	55	SAFUR80F500	6.00	2400	6
-0120-7	R6	-	-	-	75	SAFUR80F500	6.00	2400	6
-0140-7	R7	125 <sup>5)</sup>	110	90	75	SAFUR80F500	6.00	2400	6
-0170-7	R7	125 <sup>6)</sup>	110	90	75	SAFUR80F500	6.00	2400	6
-0210-7	R7	125 <sup>6)</sup>	110	90	75	SAFUR80F500	6.00	2400	6
-0260-7	R7	135 <sup>7)</sup>	120	100	80	SAFUR80F500	6.00	2400	6
-0320-7	R8	300	300	300	260	SAFUR200F500	2.70	5400	13.5
-0400-7	R8	375	375	375	375	SAFUR200F500	2.70	5400	13.5
-0440-7	R8	430	430	430	385	SAFUR200F500	2.70	5400	13.5
-0490-7	R8	550	400	315	225	2xSAFUR125F500	2.00	7200	18
-0550-7	R8	550	400	315	225	2xSAFUR125F500	2.00	7200	18
-0610-7	R8	550	400	315	225	2xSAFUR125F500	2.00	7200	18

PDM code 00096931-G

$P_{br5}$  Maximum braking power of the drive with the specified resistor(s). The drive and the chopper will withstand this braking power for 5 seconds per minute.

$P_{br10}$  The drive and the chopper will withstand this braking power for 10 seconds per minute.

$P_{br30}$  The drive and the chopper will withstand this braking power for 30 seconds per minute.

$P_{brcont}$  The drive and the chopper will withstand this continuous braking power. The braking is considered continuous if the braking time exceeds 30 s.

**Note: Check that the braking energy transmitted to the specified resistor(s) in 400 seconds does not exceed  $E_R$ .**

**R** Resistance value for the resistor assembly. **Note:** This is also the minimum allowed resistance for the brake resistor.

$E_R$  Short energy pulse that the resistor assembly withstands every 400 seconds. This energy will heat the resistor element from 40 °C (104 °F) to the maximum allowable temperature.

$P_{Rcont}$  Continuous power (heat) dissipation of the resistor when placed correctly. Energy  $E_R$  dissipates in 400 seconds.

\* ACS800-Ux types only

- 1) 240 kW possible if ambient temperature is below 33 °C (91 °F)
- 2) 160 kW possible if ambient temperature is below 33 °C (91 °F)
- 3) 630 kW possible if ambient temperature is below 33 °C (91 °F)
- 4) 450 kW possible if ambient temperature is below 33 °C (91 °F)
- 5) 135 kW possible if ambient temperature is below 33 °C (91 °F)
- 6) 148 kW possible if ambient temperature is below 33 °C (91 °F)
- 7) 160 kW possible if ambient temperature is below 33 °C (91 °F)

**Combined braking cycles for R7:**

Examples

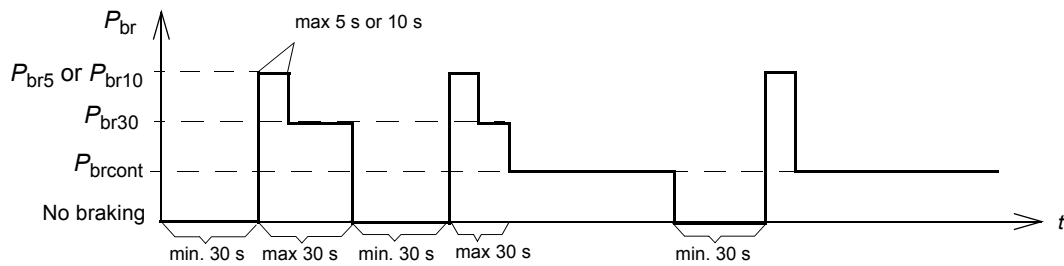

- After  $P_{br5}$ ,  $P_{br10}$  or  $P_{br30}$  braking, the drive and the chopper will withstand  $P_{brcont}$  continuously.
- $P_{br5}$ ,  $P_{br10}$  or  $P_{br30}$  braking is allowed once every minute.
- After  $P_{brcont}$  braking, there has to be at least 30 seconds without any braking if the subsequent braking power is greater than  $P_{brcont}$ .
- After  $P_{br5}$  or  $P_{br10}$  braking, the drive and the chopper will withstand  $P_{br30}$  within a total braking time of 30 seconds.
- $P_{br10}$  braking is not acceptable after  $P_{br5}$  braking.

**Combined braking cycles for R8:**

Examples

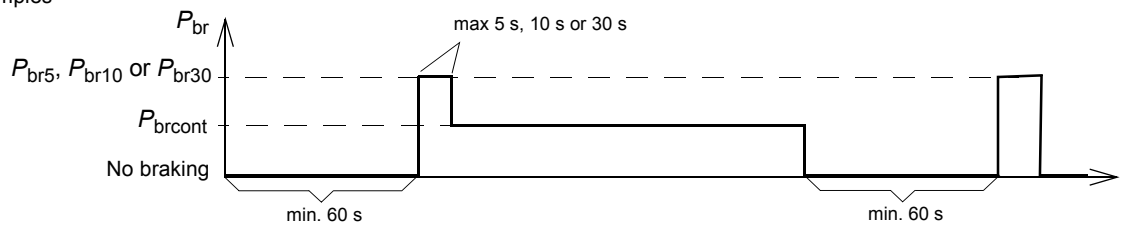

- After  $P_{br5}$ ,  $P_{br10}$  or  $P_{br30}$  braking, the drive and the chopper will withstand  $P_{brcont}$  continuously. ( $P_{brcont}$  is the only allowed braking power after  $P_{br5}$ ,  $P_{br10}$  or  $P_{br30}$ .)
- $P_{br5}$ ,  $P_{br10}$  or  $P_{br30}$  braking is allowed once every minute.
- After  $P_{brcont}$  braking, there has to be at least 60 seconds without any braking if the subsequent braking power is greater than  $P_{brcont}$ .

All braking resistors must be installed outside the converter module. The resistors are built in an IP 00 metal frame. The 2xSAFUR and 4xSAFUR resistors are connected in parallel. **Note:** The SAFUR resistors are not UL listed.

## Resistor installation and wiring

All resistors must be installed outside the drive module in a place where they will cool.



**WARNING!** The materials near the brake resistor must be non-flammable. The surface temperature of the resistor is high. Air flowing from the resistor is of hundreds of degrees Celsius. Protect the resistor against contact.

Use the cable type used for drive input cabling (refer to chapter *Technical Data*) to ensure the input fuses will also protect the resistor cable. Alternatively, two-conductor shielded cable with the same cross-sectional area can be used. The maximum length of the resistor cable(s) is 10 m (33 ft). For the connections, see the power connection diagram of the drive.

## ACS800-07/U7

If ordered, the resistors are factory installed in a cubicle(s) next to the drive cabinet.

### Protection of frame sizes R2 to R5 (ACS800-01/U1)

It is highly recommended to equip the drive with a main contactor for safety reasons. Wire the contactor so that it opens in case the resistor overheats. This is essential for safety since the drive will not otherwise be able to interrupt the main supply if the chopper remains conductive in a fault situation.

Below is a simple example wiring diagram.

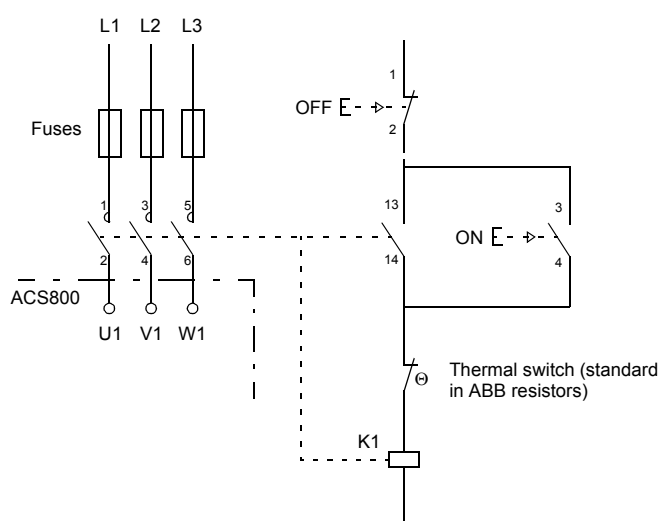

### Protection of frame size R6 (ACS800-01, ACS800-07) and frame sizes R7 and R8 (ACS800-02, ACS800-04, ACS800-07)

A main contactor is not required for protecting against resistor overheating when the resistor is dimensioned according to the instructions and the internal brake chopper is in use. The drive will disable power flow through the input bridge if the chopper remains conductive in a fault situation. **Note:** If an external brake chopper (outside the drive module) is used, a main contactor is always required.

A thermal switch (standard in ABB resistors) is required for safety reasons. The cable must be shielded and not longer than the resistor cable.

With Standard Application Program, wire the thermal switch as shown below. By default, the drive will stop by coasting when the switch opens.

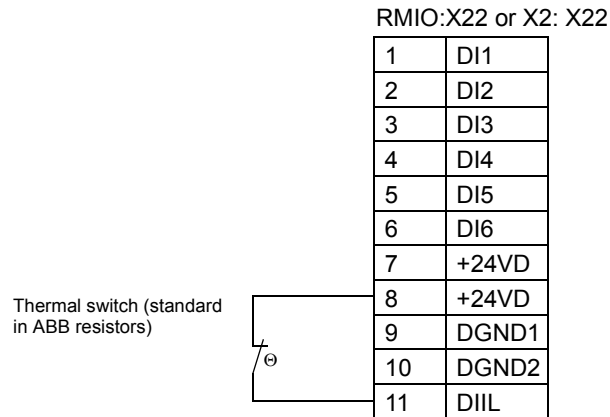

For other application programs, the thermal switch may be wired to a different digital input. Programming of the input to trip the drive by “EXTERNAL FAULT” may be needed. See the appropriate firmware manual.

## Brake circuit commissioning

For Standard Application Program:

- Enable the brake chopper function (parameter 27.01).
- Switch off the overvoltage control of the drive (parameter 20.05).
- Check the resistance value setting (parameter 27.03).
- Frame sizes R6, R7 and R8: Check the setting of parameter 21.09. If stop by coasting is required, select OFF2 STOP.

For the use of the brake resistor overload protection (parameters 27.02...27.05), consult an ABB representative.



**WARNING!** If the drive is equipped with a brake chopper but the chopper is not enabled by parameter setting, the brake resistor must be disconnected because the protection against resistor overheating is then not in use.

For settings of other application programs, see the appropriate firmware manual.





**ABB Oy**  
AC Drives  
P.O. Box 184  
FI-00381 HELSINKI  
FINLAND  
Telephone +358 10 22 11  
Fax +358 10 22 22681  
Internet <http://www.abb.com>

**ABB Inc.**  
Automation Technologies  
Drives and Motors  
16250 West Glendale Drive  
New Berlin, WI 53151  
USA  
Telephone 262 785-3200  
800-HELP-365  
Fax 262 780-5135

3AFE64671006 Rev E EN  
EFFECTIVE: 19.11.2004