



ZEPHYR INDUSTRIES

PRODUCT CATALOG

TABLE OF CONTENTS

From our beginnings as a foundry over forty years ago, in every place we've been, and every place we've touched, we've tried to make it a little better than we found it.

Every day, we go to work hoping to do two things: create a product we can stand behind and help make our customers' world a little better. It was true when Zephyr first opened in 1967, and it's just as true today.

Back then, it was a small startup company based on a strong foundry history. Built on a desire to always improve, Zephyr offered some of the industry's highest quality products. Years of engineering developments, novel designs, and high quality products created an impressive culture that carried Zephyr for over 50 years.

In 1961, Vince Richilano (Zephyr founder) first started engineering unique products for the firefighting industry. From his first invention, the Span-Hammer, Vince was drawn into helping the heroes who risk their lives each day for our safety.

In the 1980's, Zephyr started establishing itself as a market leader in Rescue Tool mounting hardware. Vince had a vision to bring the highest quality brackets to the industry. Building the company on the desire to help customers become better equipped for their challenges, he went on to develop many products for the Fire, trucking, and manufacturing industry. Many of our products have remained unchanged from his original design, simply because they are that good.

From the beginning, Zephyr set out to be a different kind of company. One that not only celebrated quality and rich heritage, but also brought a feeling of connection.

Today, with more than 200 products in 8 countries, Zephyr is the premier manufacturer of specialty mounting brackets and tool mounting in the world. And with every product, we strive to bring both our expertise and an exceptional quality to your experience with Zephyr.

The legacy continues within the passing of the torch between two families, the Richlianos and the Browns. The Browns are dedicated to improving even your smallest interaction with Zephyr. We are increasing communication, building inventory, and reducing lead times, with the desire to better serve our customers in 2014 and beyond.

We look forward to serving you and to providing the quality products you have come to expect from Zephyr.

Sincerely,

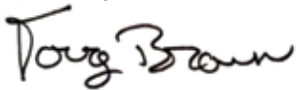

Douglas Brown

President of Zephyr Industries

RESCUE TOOL MOUNTS	4	NOZZLE HOLDERS	20
CUTTERS	6	LDH	22
SPREADERS	7	WHEEL BLOCKS	24
COMBOS	8	SPAN-HAMMERS	26
RAMS	9	HAMMERS	28
RESCUE TOOL PRODUCT LISTS		WRENCHES	29
HOLMATRO	10	SPANNER WRENCHES	30
HURST	12	WRENCH HOLDERS	32
TNT	14	CLAMPING BRACKETS	34
LUKAS	16	FORCIBLE ENTRY TOOL HOLDERS	36
AMKUS	18	CUSTOM SOLUTIONS	38
PHOENIX	19	WARRANTY	39



RESCUE TOOL MOUNTS



We protect your tools so you can protect lives.

At Zephyr Industries, we are dedicated to developing the strongest, most versatile and longest lasting rescue tool mounts in the industry. Every mount we create is designed with you in mind. Whatever rescue tool you use, our custom-designed, heavy-duty aluminum mounts protect your tools with innovative engineering and safety features.

Cast Aluminum Alloy – Heavy-Duty and Powder Coated

We create every rescue tool mount with certified solid aluminum alloy in our own foundry to ensure the highest quality castings. Heavy-duty and rugged, these mounts are engineered to withstand the abuse of every day use on fire and rescue vehicles – often outliving the extrication equipment they hold. Our mounts are powder coated to prevent oxidation and galvanometric corrosion, and packaged with stainless steel mounting hardware and speed pin retainers. If you need a custom design, our ISO:9001 certified welders can assemble mounts to your specific angle request.



Innovative Safety Features

We carry a mount for every rescue tool to guarantee a tight and secure grip on your expensive equipment. We build in anti-bounce features to hold tools in place, preventing damage to your tools and storage compartments. Strong and sturdy safety straps secure tools with constant positive tension – no more remembering if you properly secured the tool after the call.



Mounts for Every Tool and Every Brand

We have built our business on our comprehensive line of rescue tool mounts by providing options for every available brand and model on the market. Don't settle for combining random "one-size-fits-all" mounts in an attempt to secure your tools – choose mounts that will properly and safely fit your tool. Organize your storage compartment with Zephyr Industries mounts for a uniform look and style for all your tools: cutters, spreaders, combos and rams.

Brands served: Hurst, Holmatro, TNT, Amkus, Lukas, Phoenix



Multiple Mounting Positions

Our brackets offer unobstructed accessibility to your tool from any position – vertical, horizontal, 30 degree, and 60 degree mount. No need to be limited to wall and horizontal mounting – we give you control over your tool access and unparalleled flexibility when planning your storage compartment. The free-standing mounting brackets give you the power to stage your tools in a ready-to-use position so responders can quickly deploy and store tools.

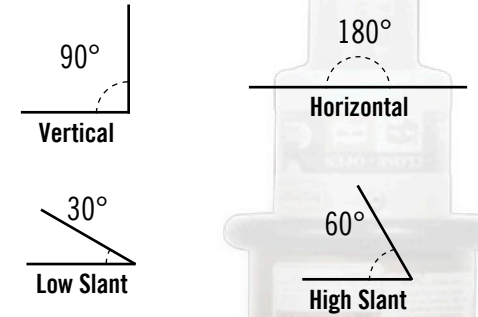

RESCUE TOOL MOUNTS

CUTTER MOUNTS

- 1. Protective edgewise mounting**
Eliminates wear and tear on your tool by contacting the jaws only
 - 2. Gravity Assist**
Self-guiding design helps you remove and replace heavy tools with ease
 - 3. Rubber Safety Hook**
Constant pressure keeps your tool securely in place
- **Heavy-duty aluminum alloy construction**
Industry-leading durability will last the life of your tool
 - **Free standing installation**
Installs anywhere within the tool cabinet so you can freely organize your tools
 - **Smallest footprint in the industry**
Free up space to fit more gear in your truck

Brand Selection

Holmatro | Pg 10 | TNT | Pg 14 | Amkus | Pg 18
Hurst | Pg 12 | Lukas | Pg 16 | Phoenix | Pg 19



Tool Tip

Freedom to Design

Imagine how a free-standing mount can change the look and feel of your rescue tool cabinet.

Experiment with placement to maximize your access and flexibility.

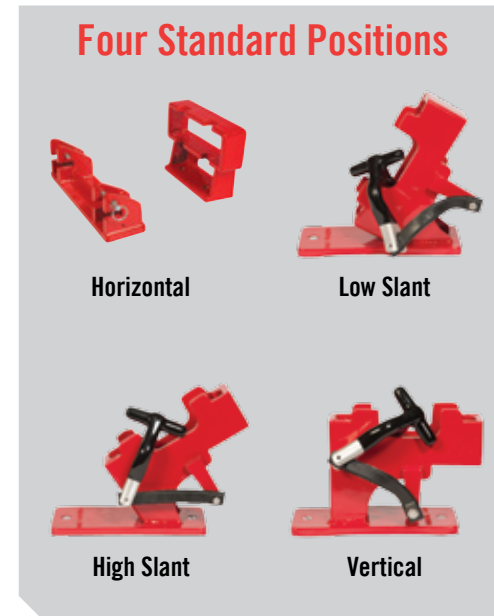

Shown in High Slant Position

SPREADER MOUNTS

- 1. Adjustable keepers**
Create a perfect, secure fit for your tool
 - 2. Triple-action anti-bounce features**
Adjustable keepers, rubber safety hook and anti-bounce engineering securely hold tool in place
 - 3. Protective edgewise mounting**
Eliminates wear and tear on your tool by contacting the jaws only
- **Heavy-duty aluminum alloy construction**
Industry-leading durability will last the life of your tool
 - **Smallest footprint in the industry**
Free up space to fit more gear in your truck

Brand Selection

Holmatro | Pg 10 | TNT | Pg 14 | Amkus | Pg 18
Hurst | Pg 12 | Lukas | Pg 16 | Phoenix | Pg 19

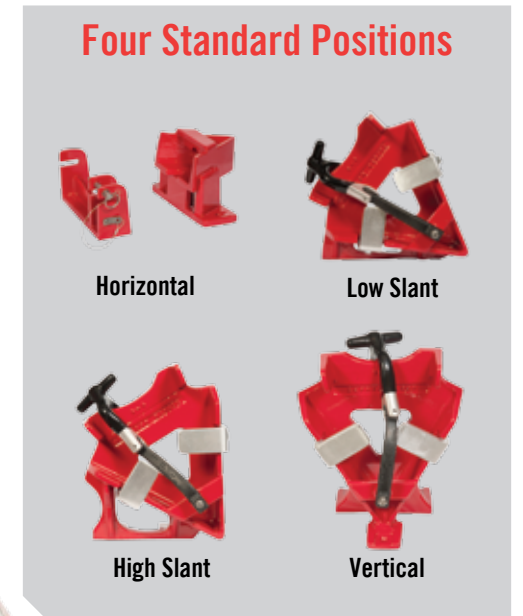

Shown in High Slant Position



Tool Tip

Mounting Options

Most horizontal mounts can also be vertically wall mounted.

RESCUE TOOL MOUNTS

COMBINATION MOUNTS

- 1. Adjustable keepers**
Create a perfect, secure fit for your tool
 - 2. Triple-action anti-bounce features**
Adjustable keepers, rubber safety hook and anti-bounce engineering securely hold tool in place
 - 3. Protective edgewise mounting**
Eliminates wear and tear on your tool by contacting the jaws only
- **Heavy-duty aluminum alloy construction**
Industry-leading durability will last the life of your tool
 - **Smallest footprint in the industry**
Free up space to fit more gear in your truck

Four Standard Positions



Brand Selection

- | | | |
|------------------|---------------|-----------------|
| Holmatro Pg 10 | TNT Pg 14 | Amkus Pg 18 |
| Hurst Pg 12 | Lukas Pg 16 | Phoenix Pg 19 |

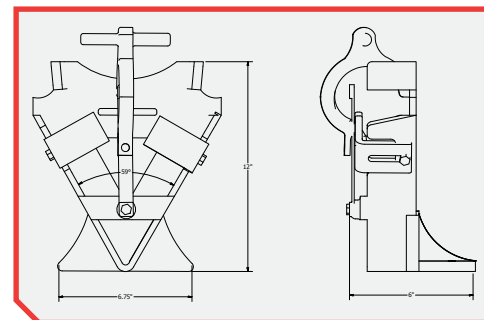

Tool Tip

Easy Storage

Fit all of your rescue tool mounts into your storage space thanks to our free-standing mount designs. For exact dimensions and design drawings, visit us at zephyrindustries.com or call us at 419-281-4485.



RAM MOUNTS

- 1. Heavy-duty aluminum alloy construction**
Industry-leading durability will last the life of your tool
- 2. Stainless steel speed pins**
Durable pins provide quick access but solid restraint when stored
- 3. Custom built design**
Designed to provide the most precise and secure fit
- 4. Versatile mounting options**
Most mount horizontally or vertically on the wall

Brand Selection

- | | | |
|------------------|---------------|-----------------|
| Holmatro Pg 10 | TNT Pg 14 | Amkus Pg 18 |
| Hurst Pg 12 | Lukas Pg 16 | Phoenix Pg 19 |



Holmatro Ram Mount shown in horizontal position

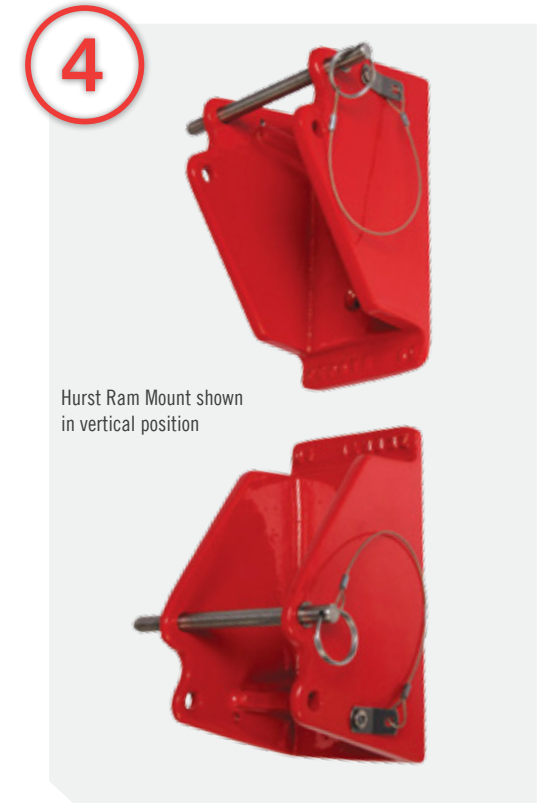

Hurst Ram Mount shown in vertical position

Tool Tip



Mounting Recommendations

We recommend reinforcing pull-out tray bottoms with 3/4" thick marine, or hard plywood, suitably waterproof treated.

Bolt tool holders through plywood and tray bottom to affect a trouble free installation.

Use flat washers against underside of tray floor before tightening bolts.

HOLMATRO HOLDERS

CUTTERS

Holmatro Model	Zephyr Model by Position			
	Horiz.	Vert.	L. Slant	H. Slant
4055	1001	1002	1003	1004
4050	1011	1012	1013	1014
4035 NCT	1021	1022	1023	1024
4035	1031	1032	1033	1034
4031	1041	1042	1043	1044
4020	1051	1052	1053	1054
2001	1061	1062	1063	1064
2009	1071	1072	1073	1074
3020	1081	1082	1083	1084
3031	1091	1092	1093	1094
3035	1101	1102	1103	1104
3040	1111	1112	1113	1114
3010	1121	1122	1123	1124
3010 HCU	1131	1132	1133	1134
4010	1141	1142	1143	1144



SPREADERS

Holmatro Model	Zephyr Model by Position			
	Horiz.	Vert.	L. Slant	H. Slant
4240	1301	1302	1303	1304
4230	1311	1312	1313	1314
4242	1321	1322	1323	1324
4260	1331	1332	1333	1334
4280	1341	1342	1343	1344
2007	1351	1352	1353	1354
2003	1361	1362	1363	1364
3230	1371	1372	1373	1374
3242	1381	1382	1383	1384
3260	1391	1392	1393	1394
3280	1401	1402	1403	1404

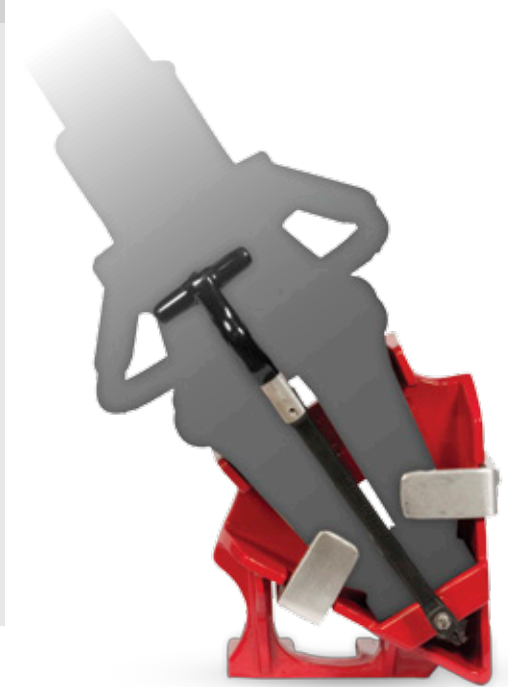

COMBINATIONS

Holmatro Model	Zephyr Model by Position			
	Horiz.	Vert.	L. Slant	H. Slant
3120	1601	1602	1603	1604
4150	1611	1612	1613	1614
3120 HCT	1621	1622	1623	1624
4120	1631	1632	1633	1634
2002	1641	1642	1643	1644
3110	1651	1652	1653	1654
3150	1661	1662	1663	1664



RAMS

Holmatro Model	Zephyr Model	Holmatro Model	Zephyr Model
	Horiz.		Horiz.
4360	1801	2005	1809
4321	1802	2006	1810
4322	1803	3321	1811
4331	1804	3322	1812
4332	1805	3332	1813
4340	1806	3340	1814
4350	1807	3350	1815
2004	1808		

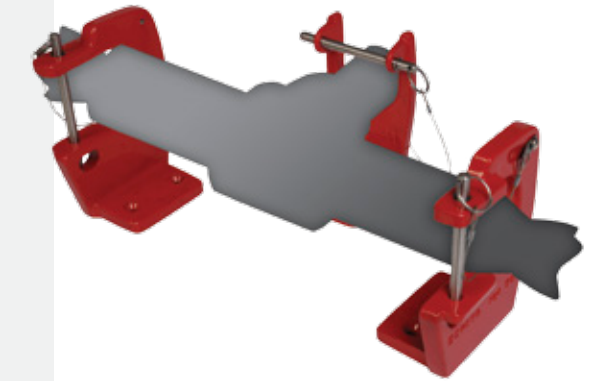

HURST HOLDERS

CUTTERS

Hurst Model	Zephyr Model by Position			
	Horiz.	Vert.	L. Slant	H. Slant
S 700 E	2001	2002	2003	2004
S 311 E	2011	2012	2013	2014
S 700	2021	2022	2023	2024
S 530	2031	2032	2033	2034
S 511	2041	2042	2043	2044
S 510	2051	2052	2053	2054
S 330	2061	2062	2063	2064
S 311	2071	2071	2072	2073
S 120	2081	2082	2083	2084
X Tractor	2091	2092	2093	2094
X Tractor II	2101	2102	2103	2104
X Tractor S	2111	2112	2113	2114
MOC ULTRA	2121	2122	2123	2124
MOC II	2131	2132	2133	2134
ML-12	2141	2142	2143	2144
ML-40	2151	2152	2153	2154
ML-50	2161	2162	2163	2164
ML-75	2171	2172	2173	2174
JL-11	2181	2182	2183	2184
JL-150	2191	2192	2193	2194
JL-500	2201	2202	2203	2204
0-90	2211	2212	2213	2214



SPREADERS

Hurst Model	Zephyr Model by Position			
	Horiz.	Vert.	L. Slant	H. Slant
SP 300 E	2301	2302	2303	2304
SP 512	2311	2312	2313	2314
SP 510	2321	2322	2323	2324
SP 310	2331	2332	2333	2334
SP 300	2341	2342	2343	2344
KL-32	2351	2352	2353	2354
ML-28 Def	2361	2362	2363	2364
ML-32	2371	2372	2373	2374
JL-32A	2381	2382	2383	2384
JL-32B	2391	2392	2393	2394
JL-27	2401	2402	2403	2404
JL-24	2411	2412	2413	2414
Transformer	2421	2422	2423	2424



COMBINATIONS

Hurst Model	Zephyr Model by Position			
	Horiz.	Vert.	L. Slant	H. Slant
SC 350 E	2601	2602	2603	2604
SC 250 E	2611	2612	2613	2614
SC 250 M	2621	2622	2623	2624
SC 557	2631	2632	2633	2634
SC 357	2641	2642	2643	2644
X Tractor C	2651	2652	2653	2654
MOC COMBI	2661	2662	2663	2664
ML-16S	2671	2672	2673	2674
SC 550	2681	2682	2683	2684
JL-16B	2691	2692	2693	2694
ML-16C	2701	2702	2703	2704



RAMS

Hurst Model	Zephyr Model	Hurst Model	Zephyr Model
	Horiz.		Horiz.
R 411E	2801	T-59	2881
R 430 Ram	2811	T-41	2891
R 424	2821	JL-60C	2901
R 422	2831	JL-30C	2911
R 420	2841	JL-20C	2921
R 414	2851	JLT-59	2931
R 412	2861	JLT-41	2941
R 410	2871	JLT-30	2951

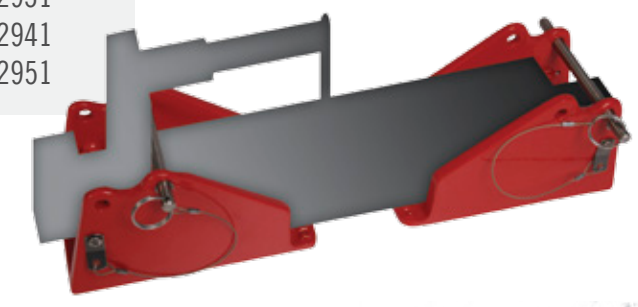

TNT HOLDERS

CUTTERS

TNT Model	Zephyr Model by Position			
	Horiz.	Vert.	L. Slant	H. Slant
SLC-24	3001	3002	3003	3004
SLC-28	3011	3012	3013	3014
SCL-29	3021	3022	3023	3024
BFC-320	3031	3032	3033	3034
SCL-24-LP	3041	3042	3043	3044
SLC-28-LP	3051	3052	3053	3054
BFC-295-LP	3061	3062	3063	3064
C-20	3071	3072	3073	3074
C-25	3081	3082	3083	3084
C-40	3091	3092	3093	3094



SPREADERS

TNT Model	Zephyr Model by Position			
	Horiz.	Vert.	L. Slant	H. Slant
SL-24	3301	3302	3303	3304
SL-28	3311	3312	3313	3314
SL-32	3321	3322	3323	3324
S-100-24	3331	3332	3333	3334
S-100-32	3341	3342	3343	3344
S-200-24	3351	3352	3353	3354
S-200-32	3361	3362	3363	3364
S-100-24-LP	3371	3372	3373	3374
S-100-28-LP	3381	3382	3383	3384
S-100-32-LP	3391	3392	3393	3394



COMBINATIONS

TNT Model	Zephyr Model by Position			
	Horiz.	Vert.	L. Slant	H. Slant
SLCC-20	3601	3602	3603	3604
SLCC-30	3611	3612	3613	3614
SLCC-30-LP	3621	3622	3623	3624
CC-20	3631	3632	3633	3634
CC-30	3641	3642	3643	3644



RAMS

TNT Model	Zephyr Model	TNT Model	Zephyr Model
	Horiz.		Horiz.
SLR-30	3801	TLS-50	3810
SLR-40	3802	R-20-LP	3811
R-20	3803	R-30-LP	3812
R-30	3804	R-40-LP	3813
R-40	3805	R-50-LP	3814
R-50	3806	R-60-LP	3815
R-60	3807	TLS-25-LP	3816
TLS-25	3808	TLS-50-LP	3817
TLS-40	3809		

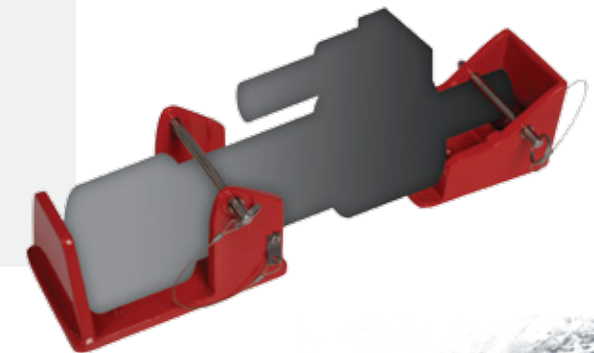

LUKAS HOLDERS

CUTTERS

Lukas Model	Zephyr Model by Position			
	Horiz.	Vert.	L. Slant	H. Slant
S 700 E	5001	5002	5003	5004
S 311 E	5011	5012	5013	5014
S 700	5021	5022	5023	5024
S 530	5031	5032	5033	5034
S 511	5041	5042	5043	5044
S 510	5051	5052	5053	5054
S 330	5061	5062	5063	5064
S 311	5071	5072	5073	5074
LS300B	5081	5082	5083	5084
LS300C	5091	5092	5093	5094
LS300EN	5101	5102	5103	5104
LS330EN	5111	5112	5113	5114



SPREADERS

Lukas Model	Zephyr Model by Position			
	Horiz.	Vert.	L. Slant	H. Slant
SP 300 E	5301	5302	5303	5304
SP 512	5311	5312	5313	5314
SP 510	5321	5322	5323	5324
SP 310	5331	5332	5333	5334
SP 300	5341	5342	5343	5344
LSP 40B	5351	5352	5353	5354
LSP 100	5361	5362	5363	5364
LSP 40EN	5371	5372	5373	5374
LSP60EN	5381	5382	5383	5384



COMBINATIONS

Lukas Model	Zephyr Model by Position			
	Horiz.	Vert.	L. Slant	H. Slant
SC 350 E	5601	5602	5603	5604
SC 250 E	5611	5612	5613	5614
SC 250 M	5621	5622	5623	5624
SC 557	5631	5632	5633	5634
SC 357	5641	5642	5643	5644
LKS35C	5651	5652	5653	5654
LKS35EN	5661	5662	5663	5664
LSI 531 CC	5671	5672	5673	5674



RAMS

Lukas Model	Zephyr Model	Lukas Model	Zephyr Model
	Horiz.		Horiz.
LTR6/570	2801	R 414	2861
LTR3.5/820	2811	R 420	2871
LZR Series	2821	R 422	2881
R 410	2831	R 424	2891
R 411E	2841	R 430	2901
R 412	2851		



AMKUS HOLDERS

PHOENIX HOLDERS

CUTTERS

Amkus Model	Zephyr Model by Position			
	Horiz.	Vert.	L. Slant	H. Slant
#25	4001	4002	4003	4004
#25-S	4011	4012	4013	4014
#25-E	4021	4022	4023	4024
#21-A	4031	4032	4033	4034
#22	4041	4042	4043	4044
30CRT	4051	4052	4053	4054



CUTTERS

Phoenix Model	Zephyr Model by Position			
	Horiz.	Vert.	L. Slant	H. Slant
CC	6001	6002	6003	6004
SB	6011	6012	6013	6014
S/B	6021	6022	6023	6024
S/O	6031	6032	6033	6034
CSB	6041	6042	6043	6043



SPREADERS

Amkus Model	Zephyr Model by Position			
	Horiz.	Vert.	L. Slant	H. Slant
#30 CX	4301	4302	4303	4304
#28	4311	4312	4313	4314



SPREADERS

Phoenix Model	Zephyr Model by Position			
	Horiz.	Vert.	L. Slant	H. Slant
35/25	6301	6302	6303	6304
49/32	6311	6312	6313	6314
Model 25	6321	6322	6323	6324
Model 32	6331	6332	6333	6334
Model 18	6341	6342	6343	6344



COMBINATIONS

Amkus Model	Zephyr Model by Position			
	Horiz.	Vert.	L. Slant	H. Slant
C-15	4601	4602	4603	4604
25C	4611	4612	4613	4614



RAMS

Amkus Model	Zephyr Model	Amkus Model	Zephyr Model
20" Vert	4801	40" Vert	4805
20" H	4802	40" H	4806
30" Vert	4803	60" Vert	4807
30" H	4804	60" H	4808

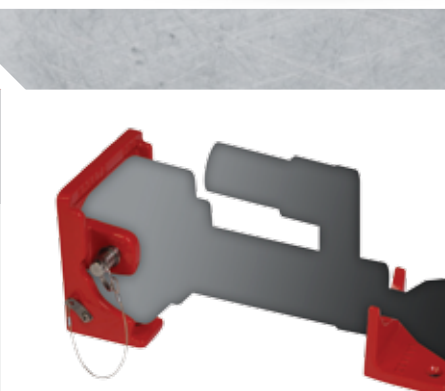

RAMS

Phoenix Model	Zephyr Model
14/27	6801
25/60	6802



NOZZLE HOLDERS

Series 1 Nozzle Holders

for up to 3 ½" barrel diameter nozzles

Ideal for booster line nozzles, preconnect hand lines, as a spare nozzle holder, or a utility bracket.

1. V-cradle design holds nozzle diameters up to 3 ½"
 2. Plastic coated cradle tips for nozzle protection
 3. Quick latch and release grip eye makes gloved operation easy
 4. Long-lasting, ozone-resistant rubber strap is durable yet replaceable
- Aluminum alloy casting for heavy-duty durability
 - Fits a wide range of nozzles yet still provides substantial grip

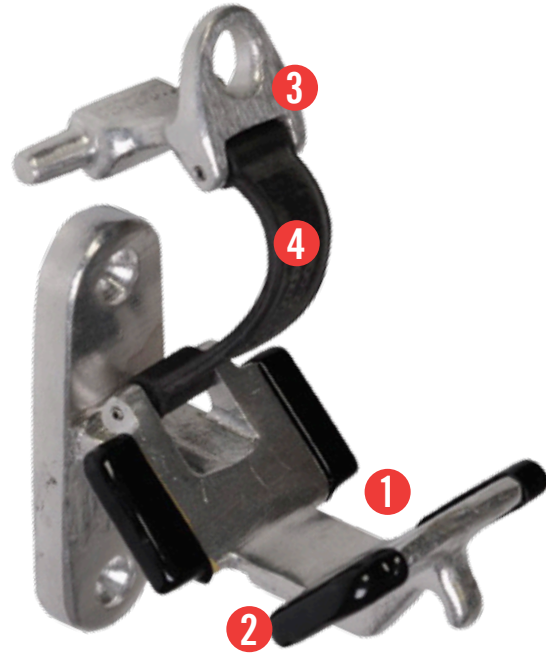

SIDE MOUNT | MODEL #95

Easy installation to side of pumper.

- Available for 2-2 ½" or 2-3 ½" nozzle barrel diameters
- Dimensions: 3" W x 5" H x 5" D
- Wt: 13 oz.



DUAL MOUNT | MODEL #96

Easy installation to deck, or side of pumper. High clearance for pistol grip models.

- Available for 2-2 ½" or 2-3 ½" nozzle barrel diameters
- Dimensions: 3" W x 6 ½" H x 5" D
- Wt: 1 lb 3 oz.



PLAY PIPE | MODEL #57

Perfect for storing your play pipe nozzle in a ready to use position. Ideal for preconnect or storage. Utilizes speed pin retainer for quick access.

- Available for up to 3 ½" nozzle barrel diameters
- Dimensions: 6" W x 9" L X 2 ½" D
- Wt: 3 lbs. 8 oz.



Series 2 Nozzle Holders

for up to 6 ¼" Bumper diameter nozzles

Designed specifically to provide best in class fit, functionality and durability.

1. Replaceable, long-lasting, ozone-resistant rubber straps extend function life
 2. Plastisol coated contact points protect your nozzle yet provide durability
 3. Easy connect straps designed for gloved hands provides quick latch and release
- Heavy-duty, aircraft quality aluminum
 - Every model is custom designed for a tight fit on your nozzle
 - Installation versatility with two mounting options



DESIGNED FOR MANY MAKE AND MODELS, INCLUDING:

AKRON BRASS	ELKHART	TFT
TurboJet Assault Tip SaberJet	Flex Attack Phantom Solid Strike Select-O-Flow Select-O-Stream Select-O-Matic Industrial Electrical Fog	Twister BubbleCup QuadraCup GForce ThunderFod Metro Mid-Force Dual-Force

REAR MOUNT | MODEL #97

Ideal for mounting at rear of pumper hose bed. Position at eye level for easy reach-in without boarding rear or deck.

- Available for 1"- 2 ½" nozzle barrel diameters
- Dimensions: 3" W x 8 ¼" H x 7 ½" D
- Wt: Approx 2 lbs. 8 oz.



SIDE MOUNT | MODEL #99

Ideal for mounting to side of pumper at cross-lay area. Right angle design allows close mounting with minimum projection.

- Available for 1 ½"- 2 ½" nozzle barrel diameters
- Dimensions: 4 ½" W x 8 ¼" H x 6" D
- Wt: Approx 2 lbs. 8 oz.



CUSTOM DESIGN

Please see price list for specific models or simply measure your nozzle in these three dimensions:

1. Bumper Diameter
2. Throat Dimension
3. Barrel Diameter

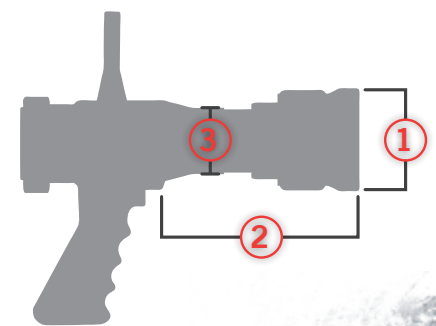

LDH HOLDERS

LDH | 101 Series

Losing your LDH Preconnect happens. Prevent this with Zephyr Travel-Lok Holders.

- Available for 4" and 5" single Storz couplings or stacked piggyback units
- Twin locking levers have automatic unlocking T-Handled speed pin release
- Innovative design built for ruggedness
- Heavy-duty all aluminum alloy casting
- Powder coated red finish
- Stainless steel hardware included

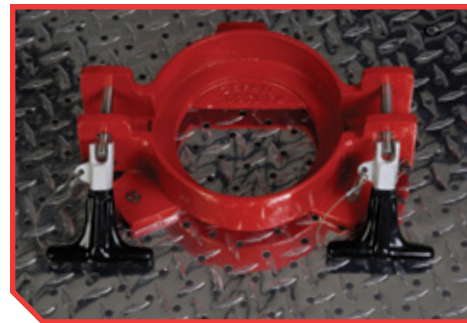

STANDARD | #101 TL

Designed to mount on the back or side at rear of vehicle.

- Wt: 5 lbs.

FLUSH MOUNTED | #101 TLFM

Designed to mount flush on rear tailboard of vehicle.

- Wt: 5 lbs.



4" Model Shown



4" Model Shown

LDH MODEL NUMBERS

#101 TL-4
4" coupling | standard mount

#101 TL-5
5" coupling | standard mount

#101 TLFM-4
4" coupling | flush mount

#101 TLFM-5
5" coupling | flush mount

#102 TL
4.5" coupling | standard mount

#102 TLFM
4.5" coupling | flush mount

Hydrant-Ready LDH | 102 Series

Be prepared to respond quickly with a hydrant-ready LDH.

- Holds 4.5" threaded couplings
- Preconnected to 4" or 5" LDH or to Storz piggyback unit
- Speed pin lock down and fast release
- Heavy-duty all aluminum alloy casting
- Powder coated red finish



STANDARD | #102 TL

Designed to mount on the back or side at rear of vehicle.

- Wt: 4 lbs.

FLUSH MOUNTED | #102 TLFM

Designed to mount flush on rear tailboard of vehicle.

- Wt: 5 lbs.



WHEEL BLOCKS

Grip Chock Wheel Blocks

We combined contoured cleats with a self-anchoring spade bar to create the most rugged, versatile wheel blocks available.

- Double strut construction for increased structural integrity
- Ribbed front sole with variable cleats
- Contoured face for enhanced grip which is used to provide better grip on your tires
- Angular spade design for increased holding power - adding pressure to the face of the chock pushes the chock against the ground for additional gripping power
- Painted yellow for easy identification
- Mounting hole for ropes, chain, or brackets
- Aluminum alloy casting and anodized for durability

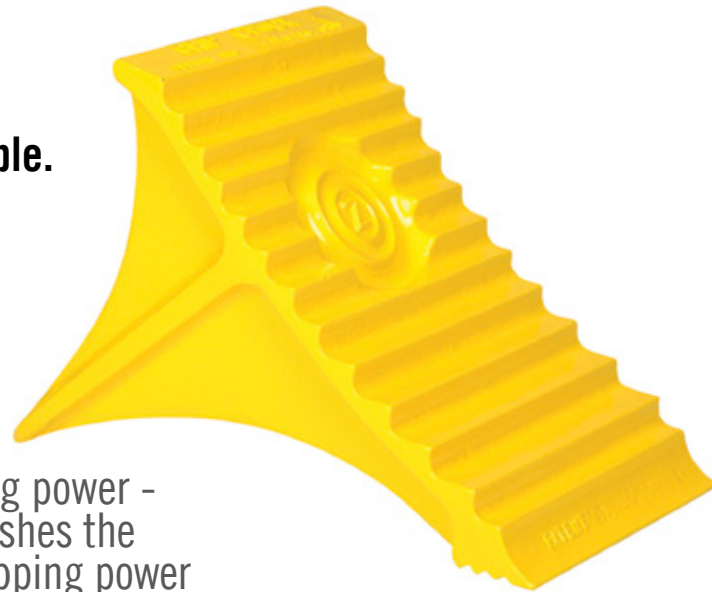

HEAVY-DUTY WHEEL BLOCK MODEL #41

Perfect for blocking of fire trucks, straight trucks, tractor trailer rigs, large R.V.'s, auto and truck wreckers, military and ordinance vehicles, school and transit buses

- Pairs with caddy (model #40) for horizontal or vertical storage
- Designed for tires up to 12" X 24"
- Dimensions: 6 3/4" W x 10 3/4" L x 7 1/2" H
- Wt: 7 lbs. 12 oz.



CHOCK CADDY FOR HEAVY-DUTY WHEEL BLOCK MODEL #40

This custom designed caddy allows secure storage of your wheel block in a vertical or horizontal position. Created for fast removal of stored block.

- Spring loaded keeper handle provides a snug fit for storage and quick release when needed
- Black Plastisol handle grip
- Dimensions: 4 1/2" W 13" L
- Wt: 4 lbs

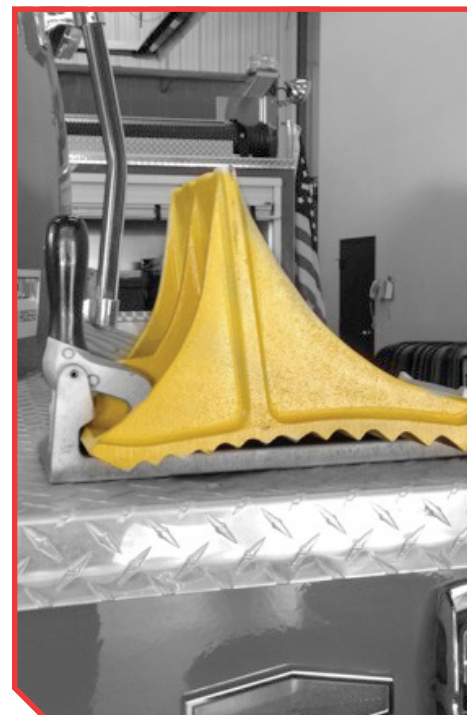

SINGLE WHEEL BLOCK MODEL #42

Ideal for pickup trucks, commercial vans, EMT vans, delivery vans, small and medium R.V.s, military and ordinance vehicles and small school buses.

- Pairs with caddy (model #45) for horizontal or vertical storage
- Designed for tires up to 8 3/4" x 16"
- Dimensions: 6 1/2" W x 7 3/4" L x 5" H



CHOCK CADDY FOR SINGLE WHEEL BLOCK | MODEL #45

This custom designed caddy allows secure storage of your single wheel block in a vertical or horizontal position. Created for fast removal of stored block.

- Spring loaded keeper handle provides a snug fit for storage and quick release when needed
- Black Plastisol handle grip
- Dimensions: 4 1/2" W x 8 3/4" L
- Wt: 1 lb. 12 oz.



Wheel Block User Guidelines:

- Improper use may result in product failure
- Select wheel block according to vehicle type and size
- Always use in pairs and on firm surfaces
- Block in direction of grade
- Block both sides of wheel if direction of grade is undetermined
- Use only after parking brake is applied and tested
- Center blocks snugly and squarely against tread of each wheel
- Always test blocks to ensure they meet requirements

SPAN-HAMMERS

Simplify your hand tools with Span-Hammers – a unique combination of a mallet and spanner wrench. Use this multi-purpose tool to quickly tighten or loosen suction hose connections. Pair with a holder for convenient and secure storage.

- No-Mar plastic striking face to rap swivel connection against seal for pressure tightness
- Solid aluminum alloy casting anodized for tough durability
- Replaceable striking cap of high density plastic extends tool life
- Pebble grain grip handle for confident grip even with a glove



SPAN-HAMMER | MODEL #31

Works great for pin lug, rocker lug, and long handle swivels.

- Pairs with holder model #32
- Dimensions: 18" L, 2 5/8" head diameter
- Wt: 2 lbs. 4 oz.



HOLDER FOR SPAN-HAMMER | MODEL #32

A handy holder with a unique ball handle clamp design for vibration-free storage and easy operation. Mount vertically or horizontally.

- Plastisol coated ball handle grip
- Dimensions: 3 1/2" W 10" L x 4 1/2" H
- Wt: 2 lbs.



KNOCK-OFF TOOL | MODEL #35

Removes damaged or worn striking caps on both Span-Hammer models (#32 and #21). Simply secure Span-Hammer in a bench vise, slip Knock-Off Tool in grooves of Span-Hammer, and gently tap off old cap.

To install new striking cap, start cap on Span-Hammer with hard twisting motion, then seat cap with a mallet or another Span-Hammer.



JUNIOR SPAN-HAMMER | MODEL #21

Great for breaking loose frozen hose connections and works well on pin lug and rocker lug connections up to 3".

- Pairs with holder model #22
- Dimension: 13" L, 2 5/8" head diameter
- Wt: 2 lbs. 4 oz.



HOLDER FOR JUNIOR SPAN-HAMMER | MODEL #22

Utilizes quick release butterfly latch that can be operated right or left hand release. Mount vertically or horizontally.

- Dimensions: 3" W x 7 1/4" L x 2 1/2" D
- Wt: 1 lb. 4 oz.



The Span-Hammer has three features to assist with tightening or loosening action hose connections:

1. Increase leverage on long handle swivels – internal cavity built to slide over and grip long handles (model #31 only)
2. No-Mar cap built to assist in freeing up stubborn connections
3. Use as spanner wrench on pin-lug and rocker lug



HAMMERS

WRENCHES

Soft-Blo Hammers

Useful for many applications – we personally use them in our machine shop, casting shake-out, and maintenance departments.

- One-piece construction provides better balance than brass hammers with wood or fiberglass handles.
- Tough aluminum alloy casting
- Good heft and balance for controlled striking
- Head and handle cast in one piece
- Broad striking face



MODEL #10

- Head dimensions: 1 ¼" OD x 3 7/8" L
- Hammer dimensions: 9" L
- Wt: 1 lb.



MODEL #20

Steel reinforced by rod cast in center through entire length for greater impact strength.

- Head dimensions: 1 ¾" OD x 4 7/8" L
- Hammer dimensions: 10 ¾" L
- Wt: 2 lbs.



MODEL #30

Steel reinforced by rod cast in center through entire length for greater impact strength.

- Head dimensions: 2 ½" OD x 5" L
- Hammer dimensions: 12" L
- Wt: 3 lbs.



Tool Tip

Give your hammer new life

After extended use, the mallet head can be reshaped to its original diameter by sanding or grinding.

Foam Cap Wrenches

Engineered specifically for loosening and tightening foam container caps.

- Tough and rugged aluminum alloy casting
- Clear anodized for extreme durability



UNIVERSAL 61MM | MODEL #61

- Fits 61mm caps
- Dimensions: 9 ½" L, 3 7/16" opening diameter
- Wt: 5 oz.



UNIVERSAL 63MM | MODEL #63

- Fits 63mm caps
- Fits Rieke style caps
- Dimensions: 9 ½" L, 3 7/16" opening diameter
- Wt: 5 oz.



UNIVERSAL 70MM | MODEL #70

- Fits 70mm caps
- Fits Rieke and Hedwyn style caps
- Dimensions: 9 ½" L, 3 ¼" opening diameter
- Wt: 5 oz.



SPANNER WRENCHES

Storz

Unique ergonomic design gives you a better grip even while wearing gloves.

- Developed specifically for Storz couplings
- Constructed of $\frac{5}{8}$ " thick solid aluminum alloy casting
- Clear anodized for tough durability in the field
- Pair with a holder for convenient and secure storage



STORZ | MODEL #15

Lightweight model with comfortable grip designed with a gas lock shut-off slot in handle.

- Fits 4"-5" Storz couplings
- Pairs with storage holders: #16, #19, #53
- Dimensions: 13 $\frac{1}{2}$ " L
- Wt. 13 oz.



STORZ/ROCKER COMBINATION WRENCH | MODEL #17

Use for Jaffrey, Angus, and other close-collar couplings, including Snaptite. Designed with a gas lock shut-off slot in handle.

- Fits 4"-5" Storz couplings
- Fits 1 $\frac{1}{2}$ " - 4" Rocker lug couplings
- Pairs with storage holder: #16
- Dimensions: 14" L
- Wt: 14 oz.



STORZ/PIN LUG/ROCKER LUG COMBINATION WRENCH | MODEL #27

Use with Jaffrey, Angus, Snaptite and other couplings as well as various short pin lug and rocker couplings.

- Fits 2"-4" pin lug couplings
- Fits 2"-4" rocker lug couplings
- Fits 4"-5" Storz couplings
- Pairs with storage holders: #16, #19
- Dimensions: 13 $\frac{1}{2}$ " L
- Wt: 13.5 oz.



UTILITY-LOCKING LEVER SPANNER | MODEL #28

Due to variations in Locking Lever Storz couplings, please specify manufacturer make and model when ordering.

- Pairs with storage holder: #14
- Wt: 1 lb.

COUPLING SIZE	WRENCH MODEL	DIMENSIONS
4"	28-4	14" long
5"	28-5	14" long
6"	28-6	15" long



Conventional

Unique ergonomic design gives you a better grip even while wearing gloves.

- Constructed of solid aluminum alloy casting
- Clear anodized for tough durability in the field
- Pair with a holder for convenient and secure storage



JUNIOR PIN-LUG ROCKER | MODEL #7

Easy grip handled designed with a gas lock shut-off slot.

- Fits 1 $\frac{1}{2}$ "-3" pin lug and rocker lug couplings
- Pairs with storage holders: #18, #54, #25
- Dimensions: 11 $\frac{1}{2}$ " L, $\frac{5}{8}$ " thick
- Wt: 10 oz.



UNIVERSAL SPANNER | MODEL #8

All-purpose wrench features belt hook eye, hammer head and gas lock shut-off slot in handle.

- Fits 1 $\frac{1}{2}$ "-3" pin lug and rocker lug couplings
- Pairs with storage holders: #25, other manufacturer universal holders
- Dimensions: 11" L, $\frac{5}{8}$ " thick
- Wt: 10 oz.



IDEAL SPANNER - POCKET SIZE | MODEL #12

Designed to easily fit in your pocket without folding.

- Fits up to 3" pin lug and rocker lug couplings
- Dimensions: 2" W x 8 $\frac{1}{2}$ " L, $\frac{3}{8}$ " thick
- Wt: 7.5 oz.



LARGE DIAMETER PIN-ROC SPANNER | MODEL #13

Specially designed to fit large diameter pin lug and rocker lug couplings

- Fits 4 $\frac{1}{2}$ ", 5", 6" pin lug and rocker couplings:
- Pairs with storage holders: #14, #19, #53
- Dimensions: 3 $\frac{1}{4}$ " W x 14 $\frac{1}{2}$ " L, $\frac{3}{4}$ " thick
- Wt: 15 oz.



LARGE DIAMETER PIN HOLE SPANNER | MODEL #5

A favorite for Red Head couplings with a hardened threaded pin.

- Fits 5"-6" couplings
- Dimensions: 12" L, $\frac{5}{8}$ " thick
- Wt: 11 oz.



WHEEL WRENCH | MODEL #6

Popular in the industrial and municipal applications, place wrench in wheel handle to open and close 2.5" valve.

- Dimensions: 12" L, $\frac{5}{8}$ " thick
- Wt: 10 oz.



WRENCH HOLDERS

Spanner Wrench Holders

Designed to keep spanner wrenches organized and protected. Provides quick, one-handed mounting and removal even while wearing gloves.

1. Spring-loaded, heavy-duty clamping heads provide secure storage and instant confirmation that your wrench is properly seated
- Tough and rugged aluminum alloy casting with stainless steel accessories
 - Clear anodized for extreme durability



DUAL PIN-ROC-STORZ WRENCH HOLDER MODEL #14

Securely stores up to two wrenches.

- Fits Zephyr wrench models: #13, #15, #17, #27, #28
- Dimensions: 4 1/8" W x 8" L x 1" D
- Wt: 2 lbs.



QUAD PIN-ROC-STORZ WRENCH HOLDER MODEL #16

Securely stores up to four wrenches.

- Fits Zephyr wrench models: #13, #15, #17, #27, #28
- Dimensions: 4 1/8" W x 8" L x 1" D
- Wt: 2 lbs.



DUAL PIN LUG/ROCKER LUG WRENCH HOLDER MODEL #25

Securely stores up to two wrenches.

- Fits Zephyr wrench models: #7, #8
- Fits Akron Brass wrench model: #10 Universal
- Fits Red Head wrench model: #101
- Dimensions: 7 1/2" W x 8 5/8" L x 1" D
- Wt: 1 lb. 8 oz.



Tri-Lok Holders

Designed to keep a variety of wrenches organized and protected. Provides quick, one-handed mounting and removal even while wearing gloves.

1. Spring-loaded, heavy-duty clamping heads provide secure storage and instant confirmation that your wrench is properly seated
- Tough and rugged aluminum alloy casting with stainless steel accessories
 - Clear anodized for extreme durability

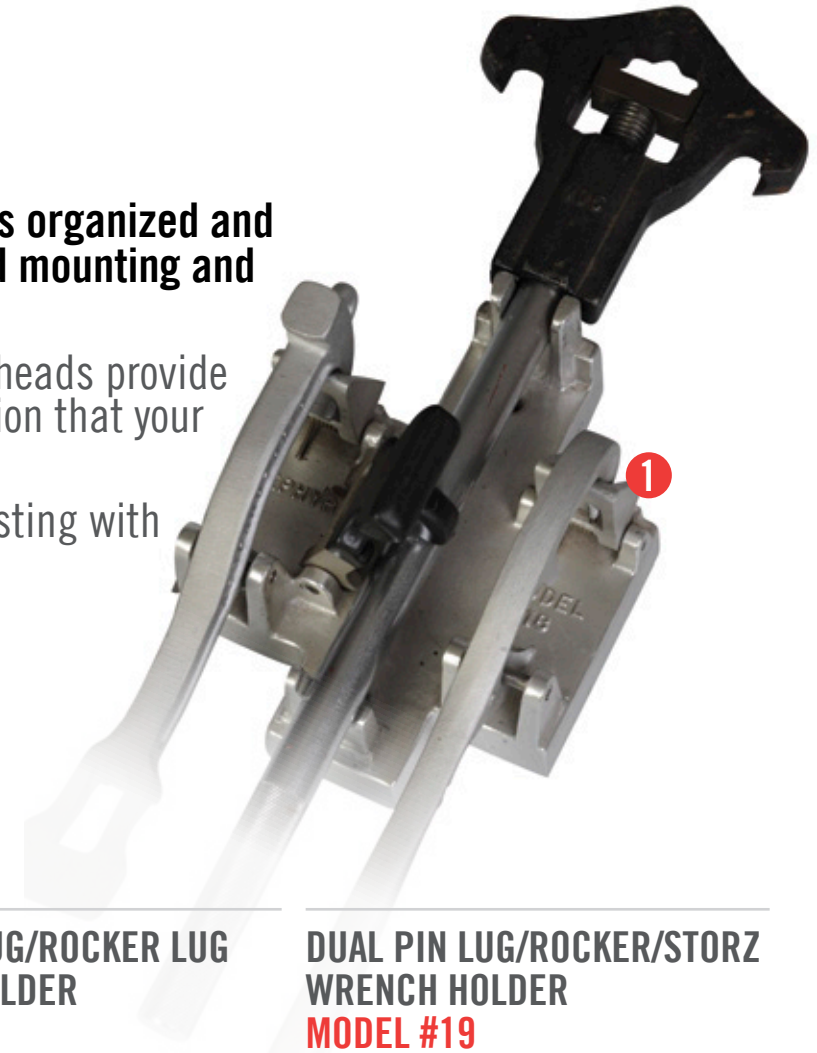

WRENCH HOLDER SELECTION

Zephyr Wrenches

Wrench Model	Zephyr Holders				
	#14	#16	#18	#19	#25
#7			x		x
#8			x		x
#13	x	x		x	
#15	x	x		x	
#17	x	x		x	
#27	x	x		x	
#28	x	x		x	

Akron Brass Wrenches

Wrench Model	Zephyr Holders				
	#14	#16	#18	#19	#25
#10			x		x
#15			x	x	
#17			x	x	

Red Head Wrenches

Wrench Model	Zephyr Holders				
	#14	#16	#18	#19	#25
#101			x		x
#105			x	x	
#107			x	x	

Elkhart Wrenches

Wrench Model	Zephyr Holders				
	#14	#16	#18	#19	#25
#454			x	x	
#S-454			x	x	

DUAL PIN LUG/ROCKER LUG WRENCH HOLDER MODEL #18

Securely stores two spade spanner wrenches and one hydrant wrench – most makes and models.

- Fits Zephyr wrench models: #7, #8
- Fits Akron Brass wrench models: #10, #15, #17
- Fits Red Head wrench models: #101, #105, #107
- Dimensions: 7 1/2" W x 8 5/8" L x 1" D
- Wt: 2 lbs.



DUAL PIN LUG/ROCKER/STORZ WRENCH HOLDER MODEL #19

Securely stores two spanner wrenches and one hydrant wrench.

- Fits Zephyr wrench models: #13, #15, #17, #27, #28
- Fits Akron Brass Hydrant wrench models: #15, #17
- Fits Red Head Hydrant wrench models: #105, #107
- Fits Elkhart wrench models: #454, #S-454
- Dimensions: 7 1/2" W x 8 5/8" L x 1" D
- Wt: 2 lbs. 8 oz.



CLAMPING BRACKETS

Tite-Grip Clamping Brackets

Use to conveniently and securely store a variety of tools, including: shovels, pike poles, axes, sledgehammers and nozzles.

- Heavy-duty clamping brackets can be mounted vertically or horizontally for customizable storage organization.
- Comfortably fits up to 2" diameter tools
- Rigid V-cradle support engineered to maximize surface area
- Spring loaded arm with "DuckBill" style design for maximum grip
- Solid aluminum alloy casting with Plastisol coated grip surfaces
- Tool Tip: Match the 3" Nozzle cup (model #83) with #87 or #85 for a flexible nozzle mount.



Tite-Grip Pike Pole Brackets

HORIZONTAL CLAMPING BRACKET | MODEL #85
• Wt: 10 oz.



HORIZONTAL RING HOLDER MODEL #86
• Wt: 10 oz.



VERTICAL CLAMPING BRACKET MODEL #87
• Wt: 10 oz.



VERTICAL RING HOLDER MODEL #88
• Wt: 10 oz.



BIGGER IS BETTER



COMPETITOR



ZEPHYR

Our larger, more durable brackets are designed to deliver.

- Stronger clamping force to securely store tools.
- Easier tool access so you can remove and replace tools quickly even while wearing gloves.

Tite-Grip Utility Brackets

VERTICAL MOUNTING CLAMPING BRACKET MODEL #81
• Wt: 16 oz.



HORIZONTAL MOUNTING CLAMPING BRACKET MODEL #82
• Wt: 16 oz.



NOZZLE CUP | MODEL #83
• Available in 3" and 4" I.D. cup diameters.
• Bottom drain holes.
• Wt: 16 oz.



ENTRY TOOL HOLDERS

Stor-Rite Holder Systems

Ideal for storing the maximum amount of tools in the least amount of space. Designed to securely store your forcible entry tools in narrow spaces in open or closed panel areas.

- Secure park position enables fast tool removal.
- Heavy-duty aluminum alloy casting
- Attractive powder coat finish



AXE AND HALLIGAN STYLE TOOL | SYSTEM #34

Three-piece system designed to store your axe and Halligan style tool in the same space.

- Three pieces: (1) pike-blade bracket, (1) axe claw bracket with speed pin retainer, (1) tie down bracket
- Marrying strap is included



HALLIGAN TOOL CHISEL DOWN SYSTEM #35

Four-piece system designed to vertically store your Halligan tool chisel end down.

- Four piece system: (1) head bracket, (1) chisel socket, (2) Tite-Grip holding brackets
- Vertical mount

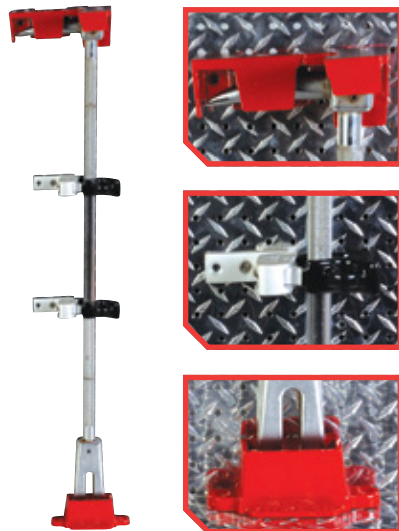

HALLIGAN TOOL CHISEL UP SYSTEM #36

Three-piece system designed to vertically store your Halligan tool chisel end up.

- Three piece system: (1) head bracket, (1) Tite-Grip holding bracket, (1) chisel guard
- All points covered for protection
- Vertical mount



FLAT WALL MOUNT | SYSTEM #37

Popular for top of engine compartment or inside cabinet wall.

- Four piece system: (1) head bracket, (1) chisel guard, (2) Tite-Grip holding brackets
- Horizontal mount

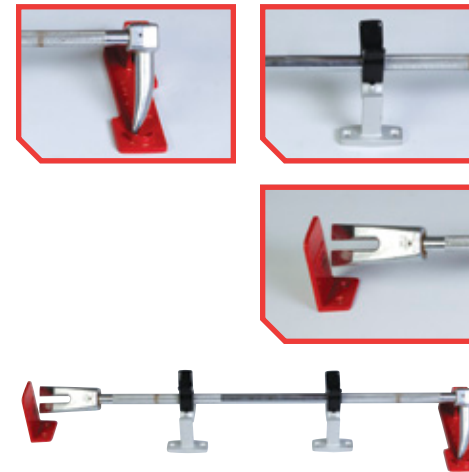

UNIVERSAL SLEDGE HAMMER HOLDER | MODEL #63

Ideal for mounting sledge hammers up to 12 lbs.

- Horizontal or vertical mount
- Speed pin retainer
- Stainless steel fasteners included
- Dimensions: 11" W x 6" H X 4" D
- Wt: 3 lbs. 8 oz.



TNT AXE HOLDER | MODEL #120

Ideal for storing the heavy-duty TNT Axe.

- Ideal holder to secure this heavy-duty tool
- Two piece unit: (1) blade bracket secures axe with speed pin, (1) captive trail bracket secures chisel hook
- Wt: 4 lbs. 8 oz.



CUSTOM SOLUTIONS

WARRANTY

Zephyr Industries is a full manufacturing facility complete with its own foundry, pattern makers, machine shop and many other offerings. Being in control of the process means we can constantly innovate and create new products to meet the ever-changing needs of our customers. We also have the ability to modify our own products to make them fit your custom solution. We specialize in creating custom designed brackets for the following industries:



FIRE INDUSTRY

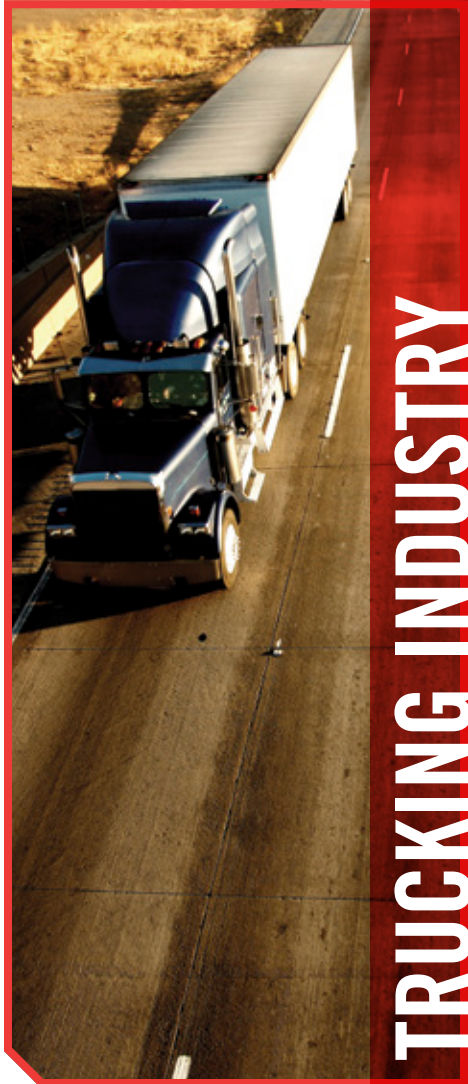

TRUCKING INDUSTRY



MANUFACTURING INDUSTRY

QUESTIONS?

Please call us at **419-281-4485** for more information or to discuss your custom solutions need.

Zephyr Industries Product Warranty | February 2014

WHO IS PROTECTED

The Zephyr Industries Limited warranty provides that all Zephyr Industries products are warranted against defects in materials and workmanship for 1 year after purchase. If we determine that one of the Zephyr products is defective, we will replace the product.

WHO PAYS FOR WHAT

Items must be returned to the factory post paid for determination of replacement/repair status. The replacement item will be shipped to customer (Buyer) at no cost.

EXCLUSIONS

This Warranty is limited and protects only the original owner and covers all defects in material and workmanship with exceptions specified as follows: (1) damage caused by accident, any unreasonable use or neglect, wear and tear, or mishandling, (2) damage occurring during shipment (claims should be presented to the carrier), (3) damage resulting from repairs or alterations by someone other than Zephyr.

EXCLUSIONS OF CERTAIN DAMAGES

Zephyr liability is limited to the replacement, at our option, of any defective product and shall in no event include incidental or consequential commercial damages of any kind. Some states do not allow limitations on how long an implied warranty lasts and/or do not allow the exclusion of incidental or consequential damages, so the above limitations and exclusions may not apply to you. This warranty gives you specific legal rights and you may also have other rights which may vary from state to state. The purpose of this exclusive remedy shall be to provide the buyer with repair or replacement of products or parts sold by Zephyr which have been found to be defective in materials or workmanship. This exclusive remedy shall not be deemed to have failed of its essential purpose so long as Zephyr is willing and able to repair or replace said defective products or parts in the prescribed manner.

TO OBTAIN WARRANTY PERFORMANCE

If your Zephyr product ever needs to be repaired or replaced, write or call Zephyr Industries. You may be asked to send your product to the factory for repairs or replacement. Please do not ship your product without prior authorization. This warranty is exclusive and Zephyr makes no other warranty of any kind whatsoever, expressed or implied, with respect to the products sold by it, whether as to merchantability, fitness for a particular purpose or any matter. No distributor, agent, employee, or representative of Zephyr has any authority whatsoever, to bind to any affirmation, representation or warranty concerning Zephyr products or parts, except as stated herein.



Info@ZephyrIndustries.com | P: 419-281-4485 | F: 419-281-4483
600 Township Rd. 1500, Ashland, OH 44805