

ERX.AV p

Adjustable handles for quick assembly



ELESA Original design



ERGOSTYLE®

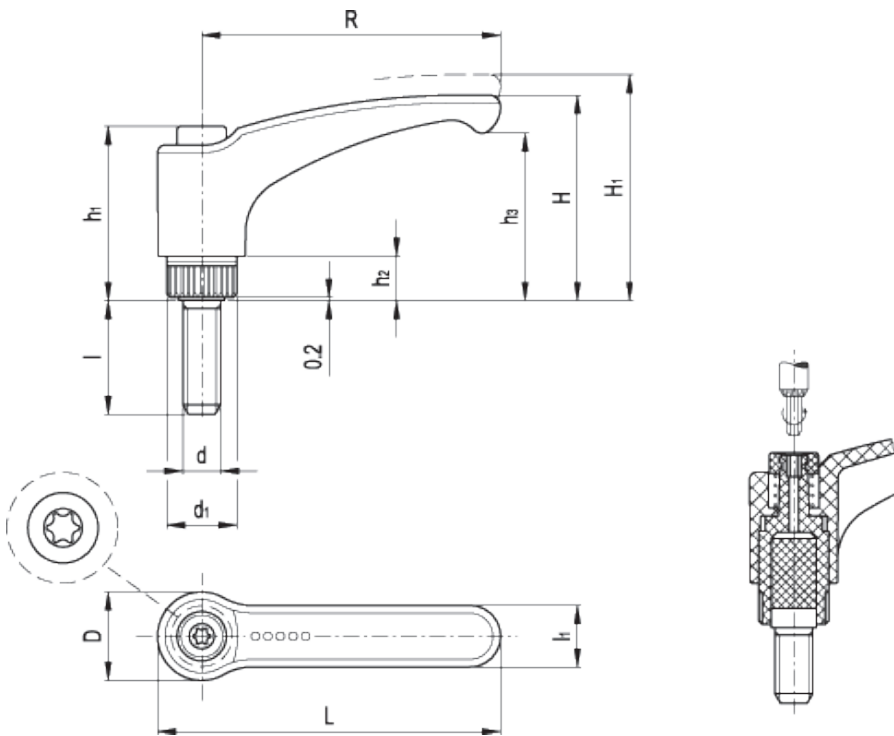

technical informations

Lever body

Glass-fibre reinforced polyamide based (PA) technopolymer. Resistant to solvents, oils, greases and other chemical agents.

Colour

Grey-black, matte finish.

Push button

Technopolymer RAL 2004 orange colour, glossy finish. On request and for sufficient quantities it can be supplied in one of the other Ergostyle colours.

Clamping element with retaining pin

Glass-fibre reinforced technopolymer, black colour, with knurling on the protruding part to make initial tightening easier. AISI 302 stainless steel return spring.

For quick assembly (ELESA patent) six-lobe socket ISO 10664 to fit TORX[®] T15 tool (registered trademark of TEXTRON INC.).

Assembly

Zinc-plated steel threaded stud, chamfered flat end according to UNI 947 : ISO 4753 (see [Technical Data](#)).

Special executions on request (For sufficient quantities)

Lever body in orange colour.

Features and applications

Even if it has a plastic push button, ERX.AV p adjustable handle offers the possibility of a quick initial screwing during assembly by means of electric or pneumatic screwdrivers with controlled tightening torque system.

Stress resistance

Adjustable handles are generally used for repetitive clamping operations sometimes with very high-frequency. Therefore, the stress resistance (i.e. the resistance to repeated tightening cycles) of the handle unit is particularly important and, especially, the strength of the toothed element which transmits the tightening force from the handle to the threaded element (boss or stud).

In fact, the results of several laboratory tests, performed with a special instrument that simulates the most severe use conditions, have shown that e.g. ERX.78 AV p adjustable handle can withstand without yielding more than 100,000 tightening cycles, under the action of a force of 490 N (see graphic).

The special glass-fibre reinforced technopolymer enables the ELESA adjustable handles to guarantee stress resistance values which are much higher than the ones generated under normal working conditions.

NUMBER OF TIGHTENINGS

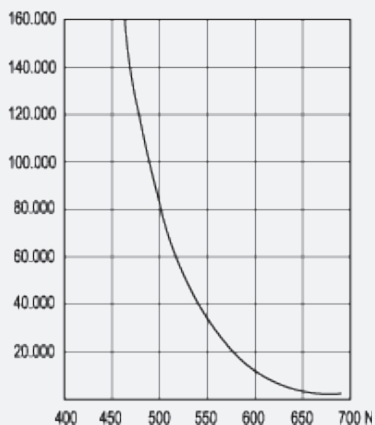

Instructions of use

For clamping, lift the lever to disengage the clamping device toothing and bring it back to start position. By releasing the lever, the return spring automatically engages the toothing.

Ergonomy and design

The slightly arched shape of the lever and the ergonomic terminal enlargement give the operator a comfortable and safe grip and make the design of the handle more elegant, while the thumb rests naturally on the push button.

The design of the lever body of this series is exactly like the design of ERX.p adjustable levers, which has been awarded by the following jurys for Industrial Design: Die Gute Industrieform Hannover 1995, Internationaler Designpreis des Landes Baden-Württemberg 1996/97.

Standard Elements		Main dimensions										Threaded stud		Teeth no.	Weight
Code	Description	R	L	D	H	H ₁	h ₁	h ₂	h ₃	d ₁	l ₁	d _{6g}	l	z	g
234518-C2	ERX.78 AV p-M10x20-C2	78	90.5	23	54	58	45	12	44	19	16	M10	20	24	58
234528-C2	ERX.78 AV p-M10x30-C2	78	90.5	23	54	58	45	12	44	19	16	M10	30	24	64
234538-C2	ERX.78 AV p-M10x40-C2	78	90.5	23	54	58	45	12	44	19	16	M10	40	24	70
234543-C2	ERX.78 AV p-M10x50-C2	78	90.5	23	54	58	45	12	44	19	16	M10	50	24	76



ELESA and GANTER models all rights reserved in accordance with the law. Always mention the source when reproducing our drawings.

STANDARD MACHINE ELEMENTS WORLDWIDE