

BRICK_5 Ford Generation 2 Upgrade Kit for vehicles with Sync and Sirius Satellite Radio

For 2011-2012 F150 with 3 button configuration

Requires:

1. Pre-programmed BL8T-18K931 (CL8T for 2012) navigation radio
Note – this upgrade kit uses the brick navigation (center stack navigation only available from factory).

Kit includes:

1. Right-hand steering wheel control (AL3Z-9C888-AA)
2. Antenna splitter (9L3Z-10E928-A)
3. F150 radio bracket (XANAVIF150Bracket)
4. Amplifier harness (4S7T-14489-YRA-3)
5. Amplifier (9L1T-18T806-A)
6. Procedure 2 harness (XP2HARNESS)
7. 2 harness pins

Sold separately:

1. Bezel
 - a. 3 Button Configuration
 - i. Black (95-5820)

Dealer will need to perform the following modifications:

For detailed installation instructions see attached Procedures

1. Swap the bracket on the navigation radio with the XanaviF150Bracket.
2. Unplug antenna from DLP and plug antenna lead into splitter. DLP is no longer needed, unplug and remove (Sirius is now integrated into Generation 2 navigation radios).
3. Replace right-hand steering wheel with factory steering wheel control for vehicles with Sync and Navigation from factory (AL3Z-9C888-AA).
4. Only perform the procedure below if Sync cannot hear your voice (see Procedure 2):
 - a. Plug provided XP2HARNESS into radio and vehicle harness.
 - b. Run and pin red & blue wire into sync module (blue to 13 & red to 12).
5. If vehicle has Sony Sound and you cannot hear the navigation voice prompts see Procedure 3.
6. After installation and microphone wiring has been completed, **if** the steering wheel control is inoperative; please contact your supplier of this part for technical support.

Notes:

1. If customer has backup camera running to rear-view mirror, installing the navigation radio will NOT automatically re-route the video to the navigation radio. A physical re-wire modification will need to take place. If the dealership chooses to do this modification or add a backup camera, they **MUST** have the navigation radio programmed to accept Backup Camera Video (Camera On). If needed, a rear camera radio input plug is available to assist in the wiring modifications or addition of a backup camera (FRD09-BC1).

Procedure #2

Microphone Wiring Instructions

Only perform this procedure if Sync *cannot* hear your voice

- 1.) Plug XP2HARNESS into radio and vehicle harness
- 2.) Run and pin red & blue wire into sync module (blue to 13 & red to 12)

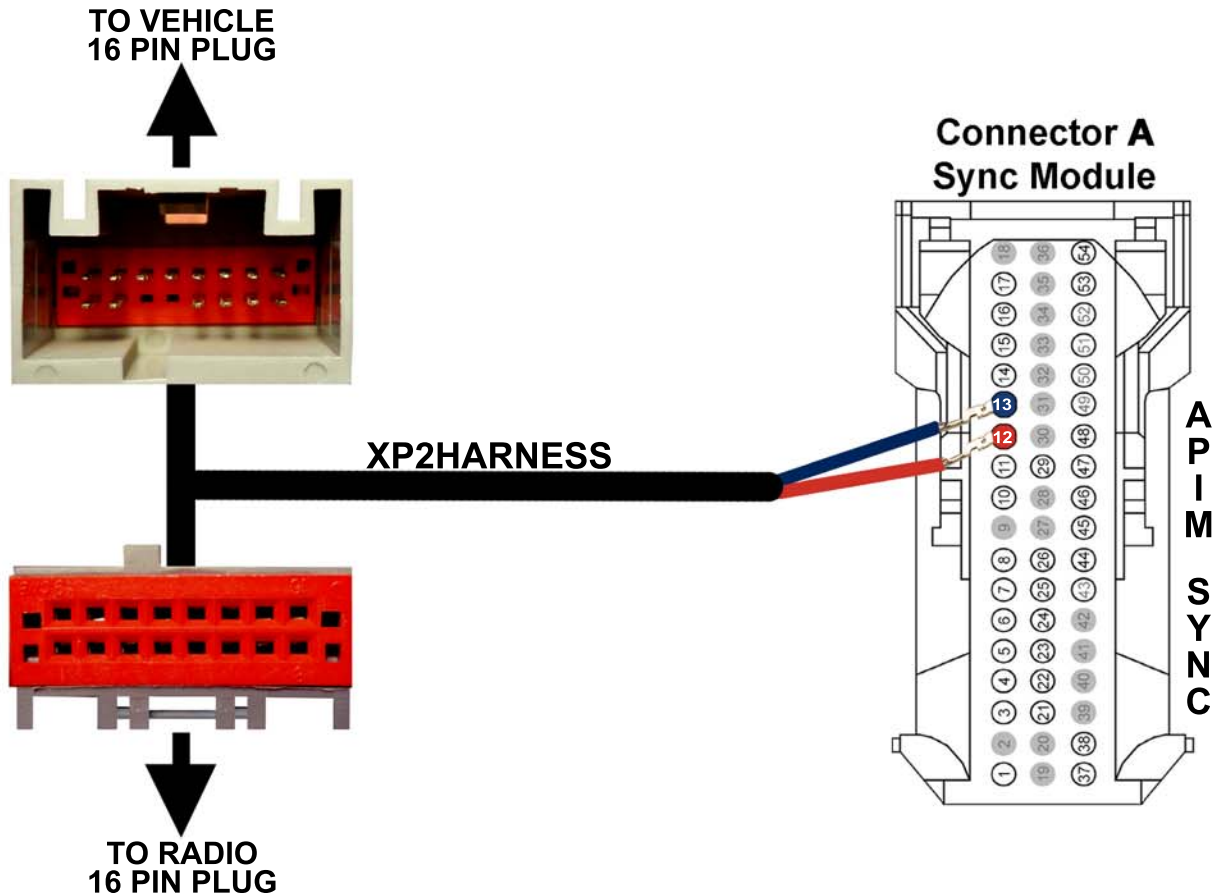

Year	Vehicle	Connector A Location	Connector A Sync Module
2009-12	Econoline	In dash below radio	C2383
2009-10	Edge	Rear of center console	C3342
2009-12	Escape	Center console	C3338
2009-12	Expedition	Bottom of center console	C3342
2009-10	Explorer	Center console	C3342
2009-12	F150	Top center of dash	C2383
2009-12	F250	Above passenger kick	C2298
2009-12	Flex	Middle of center console	C3342
2009-12	Fusion	Rear of center console	C3338
2009-11	Mariner	Center console	C3338
2009-11	Milan	Rear of center console	C3338
2009-12	MKS	Rear of center console	C3342
2009-12	MKT	Center console	C3342
2009-10	MKX	Rear of center console	C3342
2009-12	MKZ	Rear of center console	C3338
2009-10	Mountaineer	Center console	C3342
2009-10	Mustang	Behind radio	C2383
2009-12	Navigator	Bottom of center console	C3342
2008-10	Sable	Rear of center console	C3342
2009-10	Sport Trac	Center console	C3342
2008-12	Taurus/TaurusX	Rear of center console	C3342

Disclaimer This is for reference only. Before making any changes to the vehicle wiring consult the Ford service manual for verification and test all circuits.

Procedure #3

Navigation Voice Prompt Wiring Instructions for 2009-12 F150

Only perform this procedure if vehicle has Sony Sound and you *cannot* hear navigation voice prompts

- *Connect pin 2 from connector C290A to pin 4 on connector C3154A
- *Connect pin 14 from C290A to pin 14 on connector C3154A

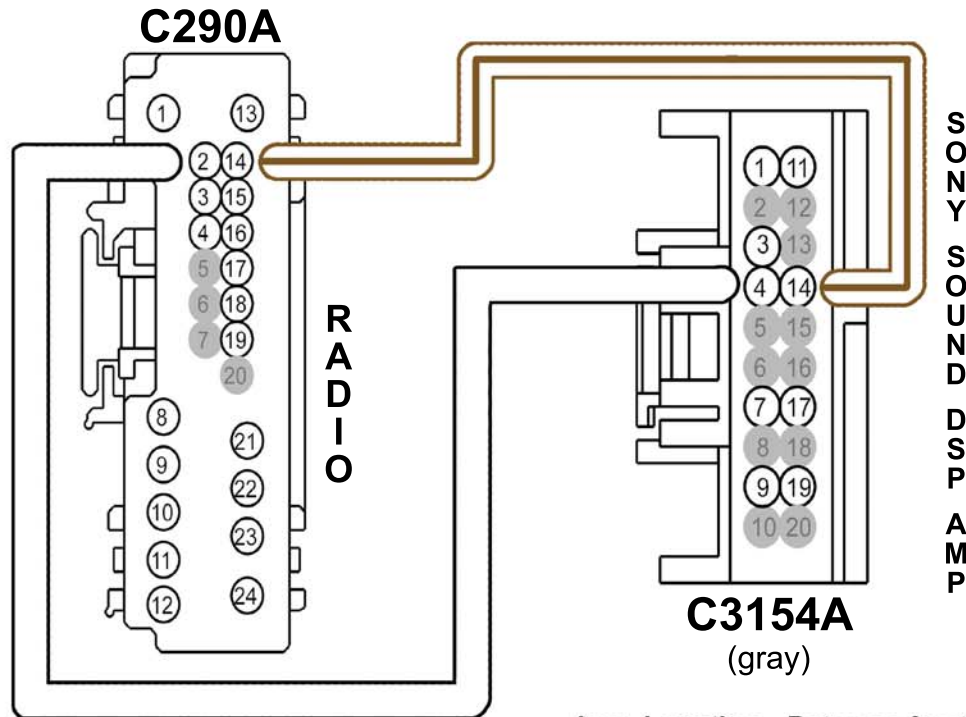

Amp Location - Between front seats mounted on transmission hump under console.

Notes: If the DSP already has wires in 4 & 14, cut and extend those wires from the amp to the radio. Insulate both remaining wire ends.

If the vehicle has Sony Sound you do **NOT use a separate amplifier**