



## Deluxe Heat & Massage Inversion Table Model ITM 4600-E

### **CAUTION:**

**WARNING:** Do not use this inversion table without a physician's approval.

Do not let children use the inversion table unsupervised.

Read all instructions carefully before using.

Tighten all bolts before using equipment.

Leave adequate space to properly invert.

### **Questions/ Comments**

**PLEASE DO NOT CONTACT THE STORE**

Elite Fitness is committed to providing the very best of quality and customer satisfaction for all of the products we distribute. If for any reason, you are dissatisfied with the product you have purchased or need assistance in any way, please do not hesitate to contact our knowledgeable support staff at: **623-888-6379**

Mon.-Fri 9:00 am – 5:00 pm Mountain Time



Photo may differ from actual product

1

# BEFORE BEGINNING ASSEMBLY...

Take a few moments to familiarize yourself with the specific parts and hardware included with your product. Make sure all the parts and hardware are included in the carton and examine them for any damage that may have occurred in transport. Some parts may be pre-assembled and pre-installed.

## **CAUTION**

### **WARNING:**

Before starting any exercise program, consult your physician.

Read all instructions very carefully before using equipment

Tighten all bolts securely before using equipment

### **Product Warranty**

#### Limited Liability

Elite Fitness warrants that this product will be free from defects in materials and workmanship for a period of 90 Days from date of purchase. This warranty applies only to the original purchaser when purchase of the product is from an authorized retailer and is for personal or household use, but not when the sale is for commercial use. This warranty is not transferable.

EXCEPT FOR THE LIMITED EXPRESS WARRANTY STATED HEREIN, Elite Fitness DISCLAIMS ALL OTHER EXPRESS OR IMPLIED WARRANTIES, INCLUDING BUT NOT LIMITED TO IMPLIED WARRANTIES OF MERCHANTABILITY AND FITNESS FOR A PARTICULAR PURPOSE. SOME STATES DO NOT ALLOW LIMITATIONS ON HOW LONG AN IMPLIED WARRANTY LASTS, SO THE ABOVE LIMITATIONS MAY NOT APPLY TO YOU.

Elite Fitness, will not be liable for any loss or damage, including incidental or consequential damages of any kind, whether based upon warranty, contract or negligence and arising in connection with the sale, use or repair of the product.

SOME STATES DO NOT ALLOW THE EXCLUSION OR LIMITATION OF INCIDENTAL OR CONSEQUENTIAL DAMAGES, SO THE ABOVE LIMITATION OR EXCLUSION MAY NOT APPLY TO YOU. THIS WARRANTY GIVES YOU SPECIFIC LEGAL RIGHTS AND YOU MAY HAVE OTHER RIGHTS THAT VARY FROM STATE TO STATE.

In the event of failure of this product to conform to this warranty during the warranty period, please call Elite Fitness Customer Service Number at 623-888-6379 for assistance in the repair or replacement of the product or any covered part. Elite Fitness will repair or replace, at its own option, the product or any covered part, except that this warranty does not cover damage caused by accident ( including transit) , or repairs or attempted repairs by any person not authorized by Elite Fitness, or by vandalism, misuse, abuse, or alteration. The Warranty Period is based on the purchase date of the product validated by the Authorized Retailers Register Receipt, or valid copy of transaction statement. Shipping and Handling is not included.

If you require service under this warranty, please call Customer Service at ( 623-888-6379)

**PLEASE DO NOT RETURN THIS PRODUCT TO THE STORE**

# Parts Listing

Part#	Description	QTY	Part#	Description	QTY
1	Bottom Front Tube	1	29	Bolt-M8x20mm	4
2	Backrest Support Tube	1	30	Oval End Caps-Foot Rest	2
3	Body Height Adjustment Tube	1	31	Base Frame End Caps-	4
4	Foot Rest Plate	1	32	Hexagonal Bolt-M8x65mm	2
5	Adjustable Leg Hold Tube	1	33	Square End Cap-for Part3	1
6	Handlebar-RIGHT	1	34	Stopper	1
7	Handlebar-LEFT	1	35	EVA Space Pad	1
8L	Base-frame-REAR-LEFT	1	36	Round End Caps	4
8R	Base-frame-REAR-RIGHT	1	37	Leg Tube Adjustment Knob	1
9L	Base-frame-FRONT-LEFT	1	38	Height Adjustment Knob	1
9R	Base-frame-FRONT-RIGHT	1	39	Metal Bushing for Rear Leg Tube 8mm	1
10	Leg Tube-REAR	1	40	Bolt-M8x45mm	1
11	Connecting Bracket	2	41	Metal Support Plate 100x38x2.5mm	2
12	Cross Bar	1	42	Bolt-M6x40mm	1
13	Foam leg Rollers	4	43	Washer- $\phi$ 18x $\phi$ 6.5x1.5	1
14	Incline Adjustment Bolt $\phi$ 13.8x88mm	1	44	Nut M6	1
15	Round Spring Insert	1	45	Plastic Washer- $\phi$ 20x $\phi$ 9.5x2.5	4
16	Spring	1	46	Round End Cap-for handlebars	2
17	Plastic Spacer	4	47	Backrest Pad	1
18	Plastic Round End-cap	2	48	Head Pad	1
19	Flat Washer $\phi$ 16x $\phi$ 8.5x1.5	23	49	Wrench-#13/#17	2
20	Bolt-M8x55mm	8	50	Hex Wrenches	1
21	Nut M8	16	51	Metal Bushing for Rear Leg Tube 5.5mm	1
22	Bolt-M8x50mm	1	52	Bolt-M8x40mm	1
23	Bolt-M8x30mm	6	53	Bottom Rear Tube	1
24	Square End Cap	6	54	Hexagonal Bolt-M8x50mm	2
25L	Handlebar Grip-LEFT	1	55	Bottom Rear Tube End Cap- $\phi$ 38	2
25R	Handlebar Grip-RIGHT	1	56	Backrest Heat & Massage Lumbar Pad	1
26	Ball Pin- $\phi$ 8x72.5mm	2	57	Power Adaptor	1
27	Bolt-M8x60mm	2	58	Hand Controller	1
28	Hexagonal Bolt-M8x20mm	2			



# Base Frame and Handlebar Assembly

## STEP 1- Base Frame

Unpack Base frame from Carton.

Attach the Bottom Front Tube(1) to the Front Baseframe(9) using 2-Bolts(32). Insert two Base Frame End Caps (31) into the Bottom Front Tube (1).

Attach the Bottom Rear Tube(53) to the Front Baseframe(9) using 2-Bolts(54). Insert two Bottom Rear Tube End Caps (55) into the Bottom Rear Tube (53).

Attach the Cross Bar(12) to the Front Baseframe(9) using 4-Bolts(20) and 2-Metal Support Plate(41),4-Flat Washers(19) and 4-Nuts(21).

Unfold Base frame- Front ( 9) from Base frame-Rear ( 8), Insert Ball Pin (26) through right side hole between the 2 frames.

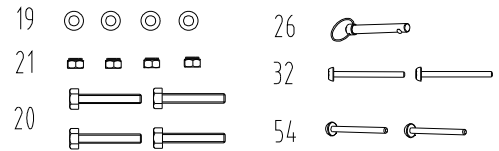

Parts Needed

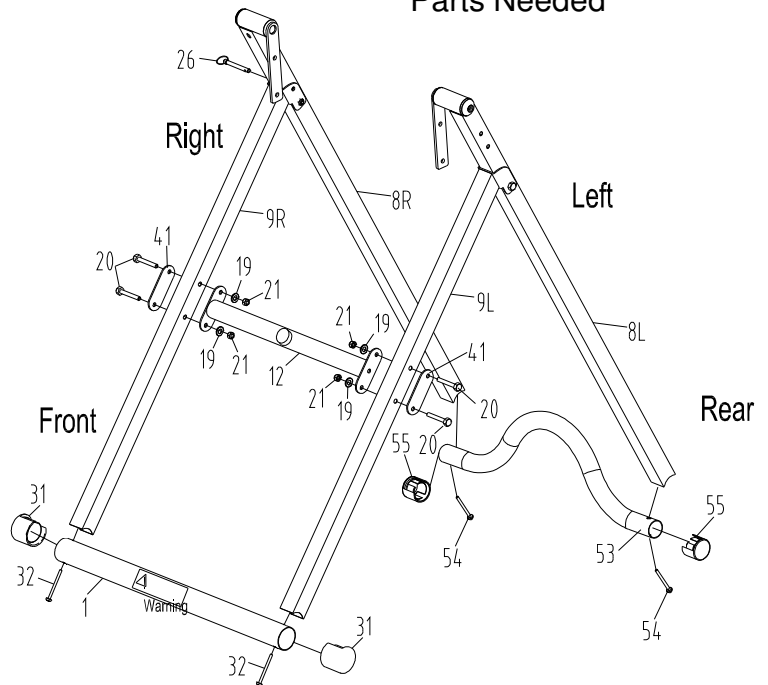

## Step 2- Installing Handlebars

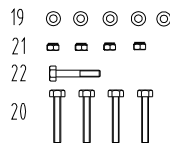

Parts Needed

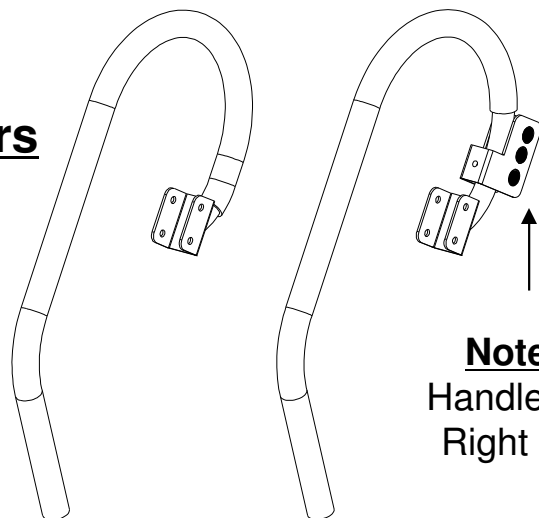

**Note:**  
Handlebar  
Right (6)

# Handlebar Assembly

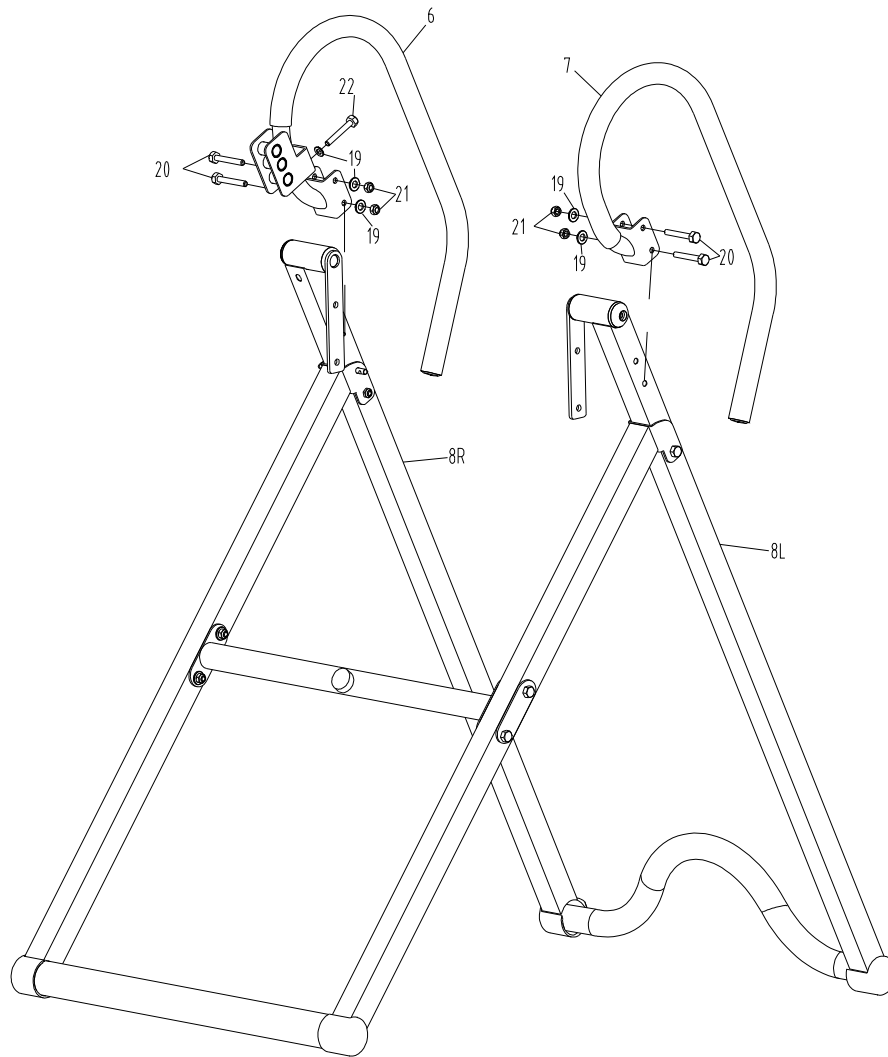

## **STEP 2 ( Cont)**

Attach the Handlebar Right (6) to the Base frame Rear(8R) using 2 Bolts (20), 2 Washers (19), and 2 Nuts (21). Use Bolt (22) and Flat Washer (19) to fix the Base frame Rear(8R) .Repeat for Handlebar Left (7) except there will not be a part 22 or 19 for this side.

**TIGHTEN ALL BOLTS AT THIS TIME**

# Backrest Assembly to Base Frame

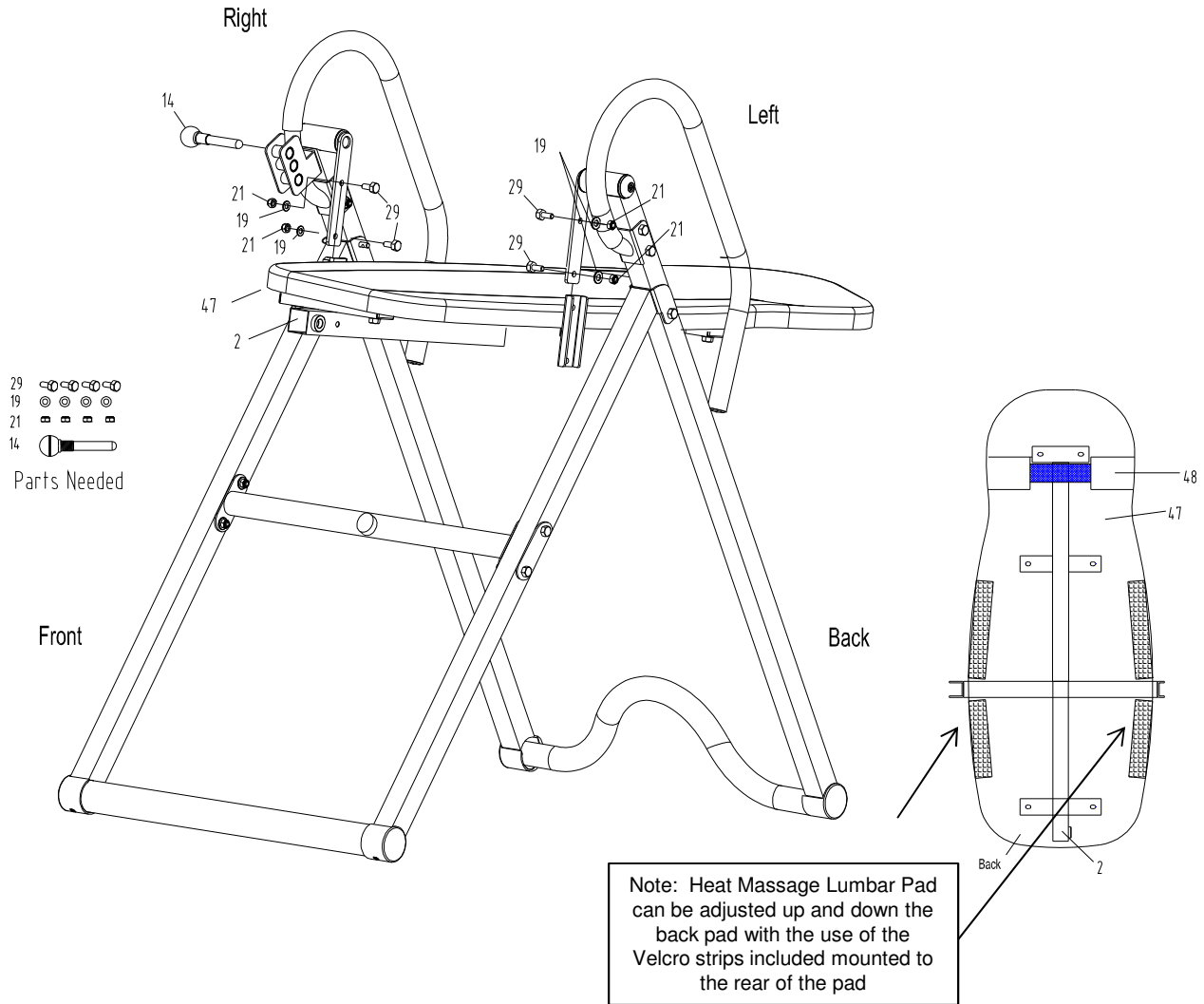

## **STEP 3 Connecting Backrest**

Attach the Completed Backrest Pad Assembly to the Base frame Unit using Bolts (29), Flat Washers (19) and Lock Nuts (21).

Install Incline Adjustment Bolt (14) into Incline Position 20 Hole and Tighten.

**NOTE: TIGHTEN ALL BOLTS AT THIS TIME**

## STEP 4-Body Height Adjustment Tube and Rollers

Install Foot Rest Plate (4) into Adjustment Tube (3) using Hexagonal Bolt (52), Metal Bushing (51) Flat Washer (19) and Lock Nut (21).

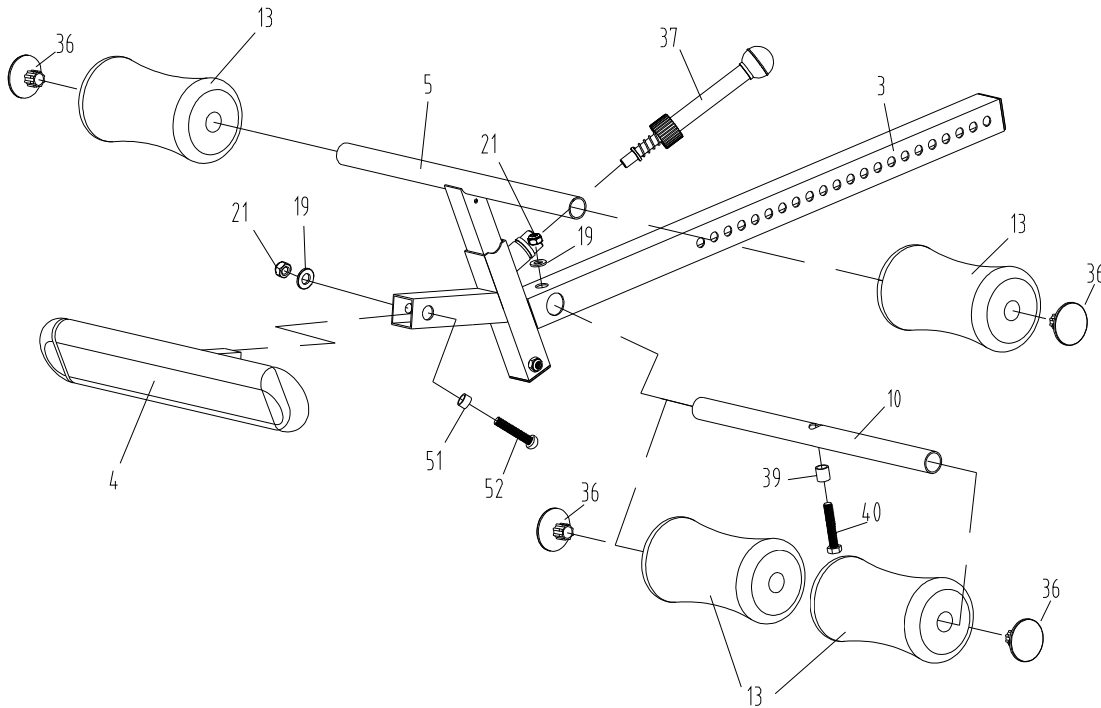

Pull out Adjustable Leg Hold Tube(5) and position horizontally as shown.( This will have spring pre-assembled inside Tube from factory which should not be removed)

Install Leg Tube (10) through hole in Adjustment Tube (3) using Hexagonal Bolt (40), Metal Bushing (39) Flat Washer (19) and Lock Nut (21)

Insert Leg Tube Adjustment Knob (37) into threaded hole in Adjustment Tube (3) and tighten.

Slide Foam Leg Rollers (13) over Leg Tube-Rear (10) and over Leg Hold Tube (5) and cap ends with 4-Round End Caps (36) .

**NOTE: TIGHTEN ALL BOLTS AT THIS TIME**



## STEP 5-Final Assembly

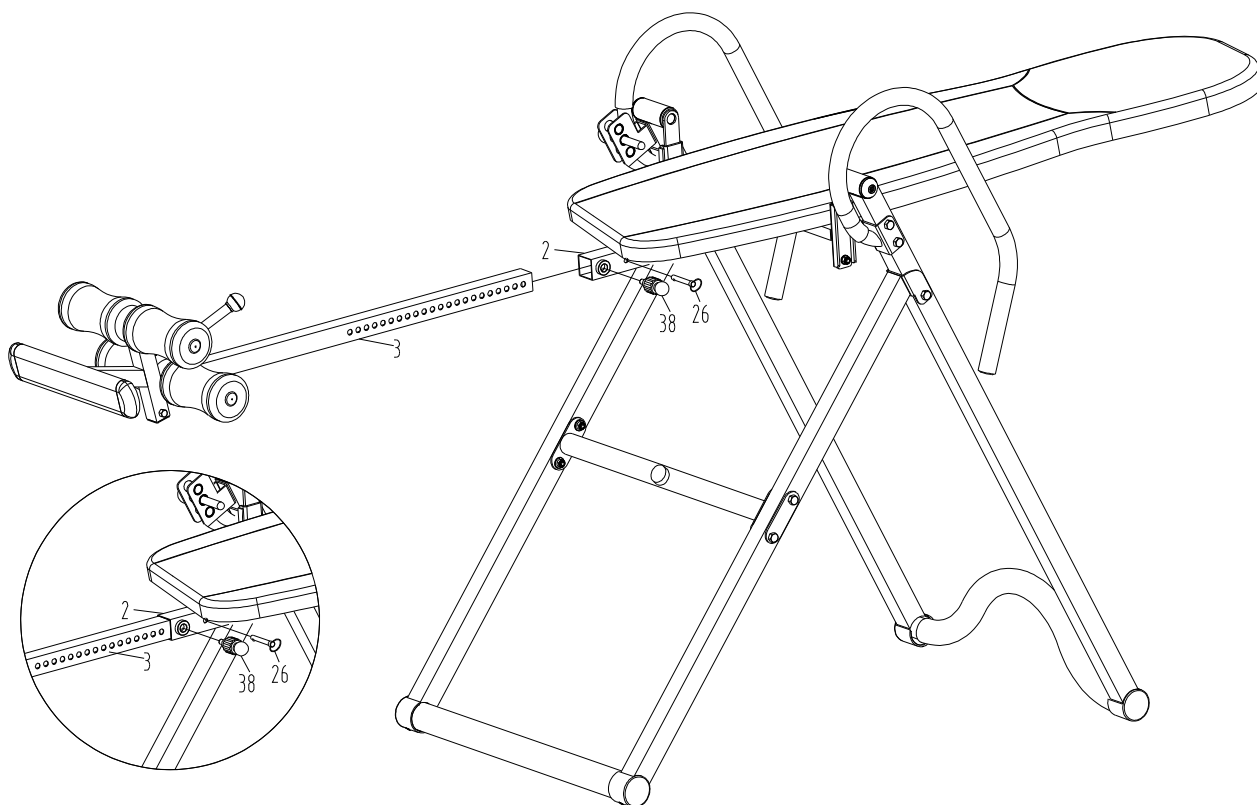

Slide Height Adjustment Tube (3) into Backrest Support Tube (2) and lock into place using Height Adjustment Knob (38).

Ball Pin (26) is used to lock Height Adjustment Tube in place when desired Height Adjustment is obtained.

Note: This product is designed to adjust from 5'1" to 6'6" with a Maximum User Weight of 300 LBS.

# Heat/Massage Pad and Head Pad Assembly to Backrest Pad

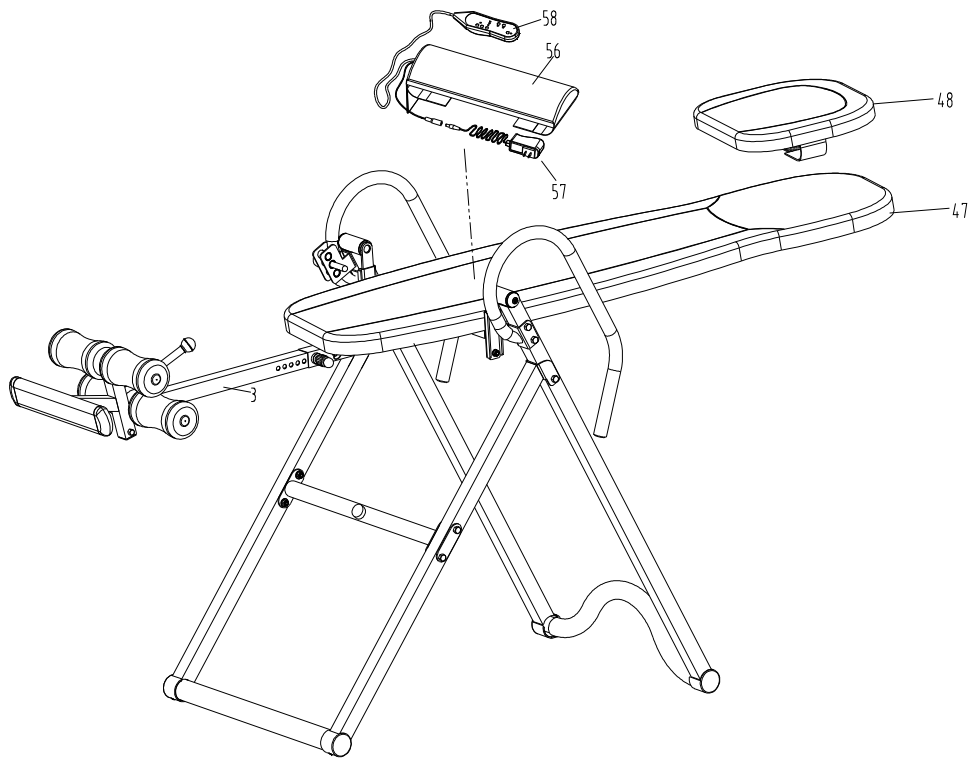

## **Step 6 Connecting Head Pad and Massage/Heat Pad**

Attach the Backrest Massage/heat Pad(56)and the Head Pad(48) to Backrest Pad(47) in Desired Position using Velcro. Controller(58) can be stored in Right Side Pocket of Backrest Pad(47) for easy access.

Note: Please pay attention to the power cord not be squeezed by the inversion table when using it.

## Final Assembly

**Make Sure All Nuts  
Bolts and Screws are  
Completely Tightened  
Before Use.**



# Controller Instruction

Connect the product with power source by 12V 1.2A adaptor and the indicator light of "POWER" will blink into standby.

Press "AUTO" button and the massage modes and intensities will automatically change once every 20 seconds from mode one to mode seven.

Press "MANUAL" button to cancel the auto mode and start the manual mode. Press "MANUAL" button to change the massage modes. The indicator light of "MANUAL" is Green.

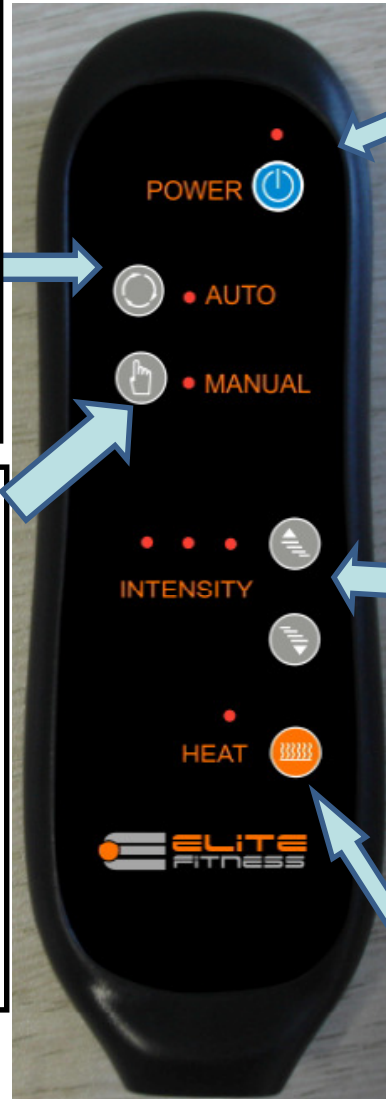

Press the "POWER" button to start the massage function, the power indicator light will stop blinking, the massage function will start in AUTO mode with 2nd level intensity .

In Auto or Manual modes Press "Up" and "Down" button to change the intensity of massage function, there are 3 levels. When one indicator light of "INTENSITY" is blinking it's level one, two indicator lights is level two, three indicator lights is level three.

Press "HEAT" button to start the heat function. The indicator light of "HEAT" is red. Press again to stop the heat function, the indicator light is out.

## Note:

**For Safety DO NOT use more than 30 minutes per session.**

**If the unit is on and unattended it will auto shut off at 15 minutes.**

# PRECAUTIONS

## **WARNING: 300 LB WEIGHT CAPACITY**

**To reduce the risk of serious injury, read all important precautions instructions and warnings in this manual before using the Inversion System. Elite Fitness, or Extreme Products Group assumes no responsibility for personal injury or property damage sustained by or through the use of the Inversion System.**

## **DO NOT USE THIS INVERSION TABLE WITHOUT A PHYSICIAN'S APPROVAL, OR IF YOU HAVE ANY OF THE FOLLOWING CONDITIONS**

(this list is for reference only, it is not an exhaustive listing):

Pregnancy; Hiatal Hernia, ventral hernia; glaucoma, Retinal Detachment or Conjunctivitis; High Blood Pressure, Hypertension, recent Stroke or Transient Ischemic Attack; heart or Circulatory Disorders for which you are being treated; Spinal Injury; Cerebral Sclerosis; Acutely Swollen Joints; Bone Weakness ( Osteoporosis ), recent unhealed fractures, medulary pins and surgically implanted orthopedic supports; the use of anticoagulants, including high doses of aspirin; Middle Ear Infections, Over weight or Extreme Obesity.

**IF YOUR PHYSICIAN PERMITS YOU TO USE INVERSION THERAPY, DO SO UNDER THEIR DIRECTION AND HAVE OUR GUIDELINES APPROVED BY YOUR PHYSICIAN.**

**DO NOT LET CHILDREN USE THE INVERSION TABLE UNSUPERVISED.**

**THERE ARE CERTAIN PEOPLE WHO SHOULD NEVER INVERT. IF YOU THINK YOU BELONG TO THIS MINORITY, PLEASE CHECK WITH YOUR PHYSICIAN BEFORE USING THIS INVERSION TABLE.**

**INSURE THAT ALL NUTS, BOLTS, AND SCREWS ARE COMPLETELY TIGHTENED BEFORE USING THIS PRODUCT.**

**SECURE YOUR ANKLES AND LOCK PULL PIN IN PLACE BEFORE INVERTING.**

# USAGE GUIDELINES



## **INVERSION SELECTOR PIN**

Familiarize yourself with the Inversion Selector Pin located on the Right Side of the Inversion Table. The positioning of the pin will determine the degree of Inversion that you are comfortable with.

The 3 selections are:

20- Slight Inversion

40-Moderate Inversion

60- Enhanced Inversion

**NOTE: IT IS STRONGLY RECOMMENDED THAT SOMEONE BE WITH YOU DURING INVERSION. ALTHOUGH THE INVERSION TABLE IS EASY TO USE, HAVING SOMEONE NEARBY TO “SPOT” YOU WILL PROVIDE EXTRA SAFETY AND SUPPORT TO THE INVERSION PROCESS.**

## **Body Height and Weight Adjustment:**



**Before Starting, insure that the Inversion Table is at the correct settings to match your height and weight. As each individual's body type is different, you will need to find the correct settings for your specific body type**

# USAGE GUIDELINES- Securing Feet and Ankles

**WARNING:** ALWAYS WEAR ATHLETIC SHOES WITH LACES TIGHT TO HELP SECURE YOUR FEET IN THE INVERSION SYSTEM, AND FOR FOOT PROTECTION WHILE EXERCISING.

ALWAYS MAKE SURE THAT THE ANKLE LOCK IS SECURED SNUGLY AGAINST YOUR ANKLES AND THAT THE LONG KNOB IS FULLY TIGHTENED BEFORE YOU USE THE INVERSION SYSTEM

**Step 1-** Expand the front rollers by pulling up on the Leg Tube Adjustment Knob ( 24)



**Step 2-** Slide Feet under Foam Rollers

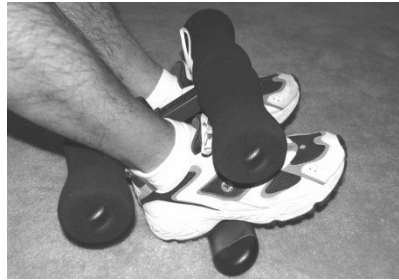

**Step 3-** Contract the front rollers snugly over feet by releasing the Leg Tube Adjustment Knob and making sure it securely “Locks” into place as photo **A**.

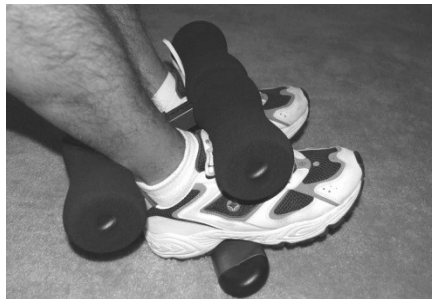

(A)

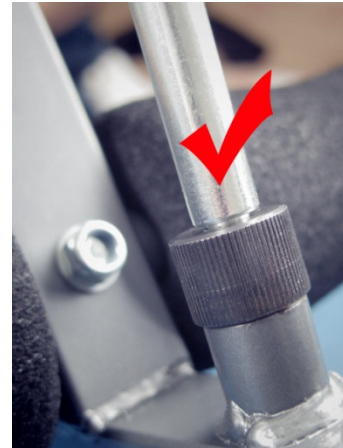

(B)





# USAGE GUIDELINES



## Finding the Proper Height and Weight Adjustment

With head flat on back pad, slowly raise one arm up toward the ceiling. If the bed starts to invert backward, the height adjustment should be correct.

If the bed does not start to invert, adjust the center slider arm upward one position at a time, until the bed starts to invert backward. Remember to use very slow arm movements.



By raising both hands over your head, the Inversion Table should now invert to a greater degree, provided that you are comfortable with the side adjustment knob being set to 20 or higher.

**Note:** It is recommended that beginners use the setting marked 20 for Partial Inversion.



With proper supervision, and provided you are comfortable with the side adjustment knob being set to 40 or 60, the Inversion Table will now allow for a more complete Inversion position.

**CAUTION: BY LOWERING THE HANDS BACK TO THE STARTING POSITION, THE INVERSION TABLE SHOULD REVERT BACK TO THE UPRIGHT POSITION. IF IT DOES NOT, USE THE BUILT IN SIDE HANDLEBARS TO PULL YOURSELF BACK UP AND RE-ADJUST THE CENTER SLIDER TO ACCOMMODATE YOUR BODY WEIGHT AND TYPE.**



## **ELITE FITNESS**

**Distributed By:**

**Extreme Products Group**

**6635 W. Happy Valley Rd**

**Suite A-104, #213**

**Phoenix, AZ 85310**

**Phone: 623-888-6379**

**Fax: 623-434-9100**

**[service@extremeproductsgroup.com](mailto:service@extremeproductsgroup.com)**

**For All parts requests, please visit our web  
site at [www.extremeproductsgroup.com](http://www.extremeproductsgroup.com)**