

H Y P E R M A X I

PAGE 1 OF 8

ASY 083

INSTALLATION INSTRUCTIONS

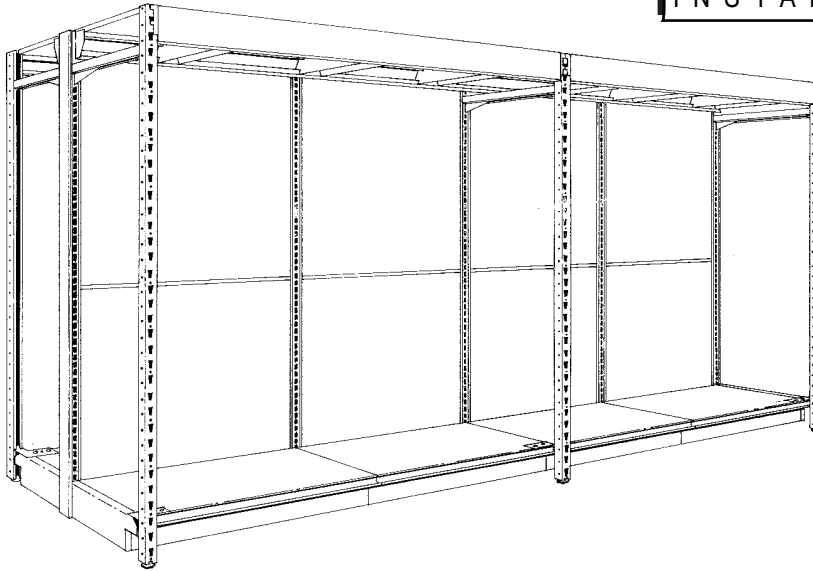

ALL CARTONS
CONTAINING
HYPERMAXI
PARTS
ARE LABELED

O P E N

6

S I X T H

PAGE 2-3 PARTS IDENTIFICATION
PAGE 4-6 BASIC INSTALLATION
PAGE 7INSTALLATION OF EXTRAS
PAGE 8SAFETY/ LOAD CAPACITY

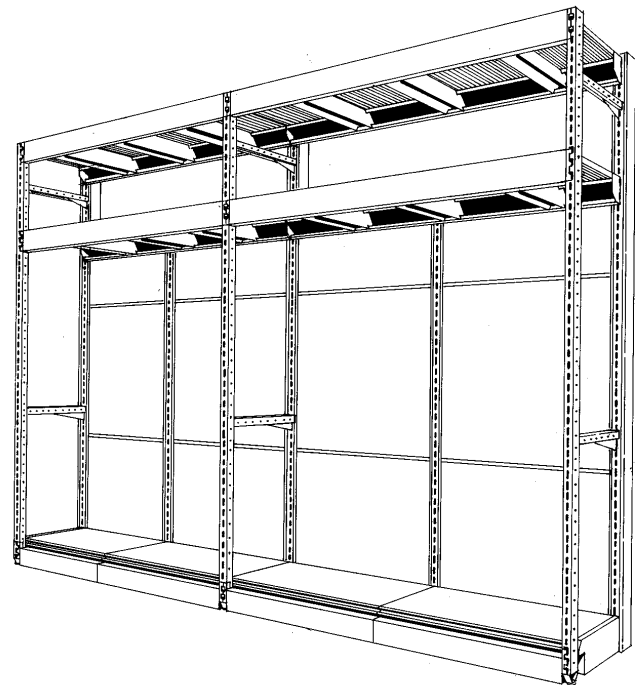

NOTE!

This publication is intended to be a generic installation instruction for Madix Hypermaxi, and may possibly be subject to change as required by local building codes. Consult the building inspection department at job site.

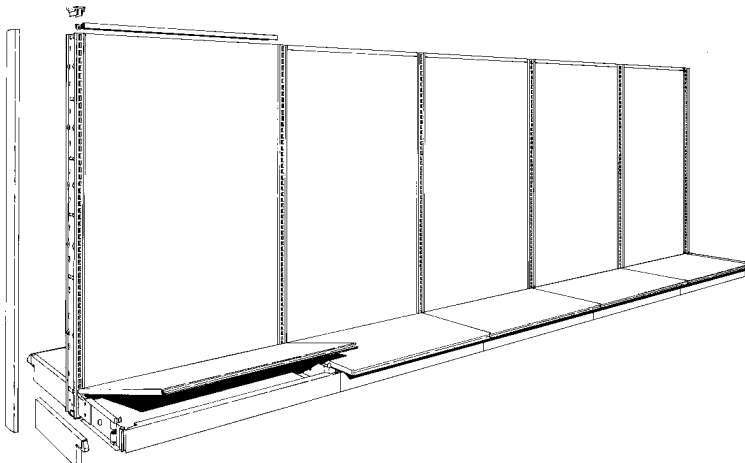

Hypermaxi is an addition to Madix gondola or wall fixtures. See installation instruction ASY 046 to correctly install and level the fixture runs. If floor anchoring of the fixtures is required, see ASY 357 for the correct procedure, and note that **IT IS NOT REQUIRED TO ANCHOR THE HYPERMAXI UPRIGHTS,** only the fixture base shoes or uprights.

madixTM
STORE FIXTURES

P.O. BOX 729 / TERRELL, TEXAS 75160 / 972.563.5744 / 800.776.2349

P.O. BOX 177 / GOODWATER, ALABAMA 35072 / 205.839.6354 / 800.633.6282

REV
A

H Y P E R M A X I

PARTS IDENTIFICATION

FRONT BEAMS

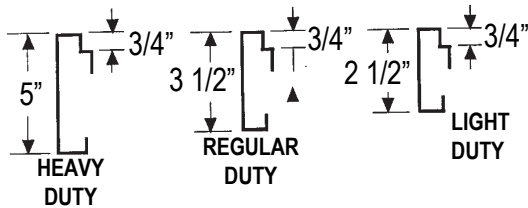
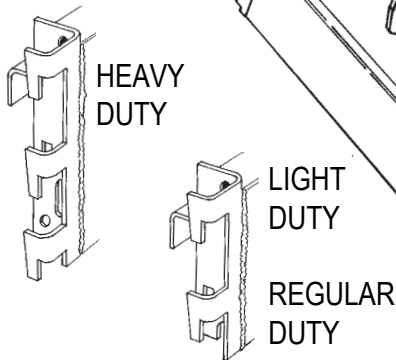

FB = FRONT BEAM
RB = REAR BEAM

HYPERMAXI HMRDFB□□

LIGHT DUTY = LD BEAM LENGTH
REGULAR DUTY = RD
HEAVY DUTY = HD

REAR BEAMS

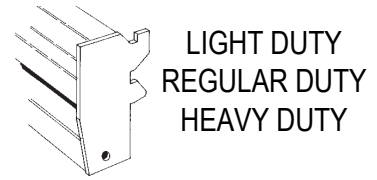

D I M E N S I O N S				
Deck Supports		Beams	Front	Rear
Upright	Actual	Beam	Actual length	
Depth	Length	Length	I.D. of Brackets	
18"	20"	36"	33 15/16"	35 21/32"
20"	22"	48"	45 15/16"	47 21/32"
22"	24"	72"	69 15/16"	71 21/32"
24"	26"	84"	81 15/16"	83 21/32"
30"	32"	96"	93 15/16"	95 21/32"

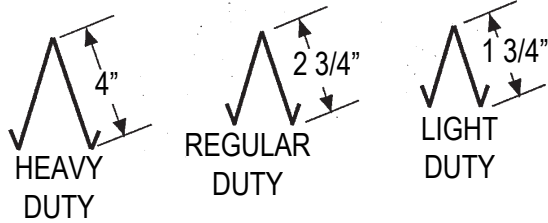

LIGHT DUTY = LD
REGULAR DUTY = RD DECK SUPPORT
HEAVY DUTY = HD

RDWSDS□□

WIDE FRAME
SPAN DEPTH

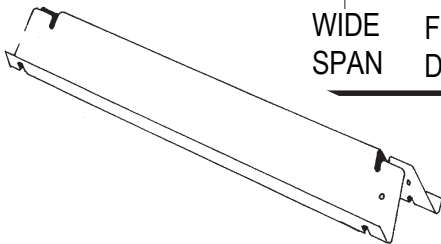

UPRIGHT DIMENSIONS			
Upright	Actual	Upright	Actual
Depth	Depth	Height	Height
18"	20"	72"	72 1/8"
20"	22"	78"	78 1/8"
22"	24"	84"	84 1/8"
24"	26"	90"	90 1/8"
30"	32"	96"	96 1/8"
		102"	102 1/8"
		108"	108 1/8"
		114"	114 1/8"
		120"	120 3/16"
		126"	126 3/16"
		132"	132 3/16"
		138"	138 3/16"
		144"	144 3/16"

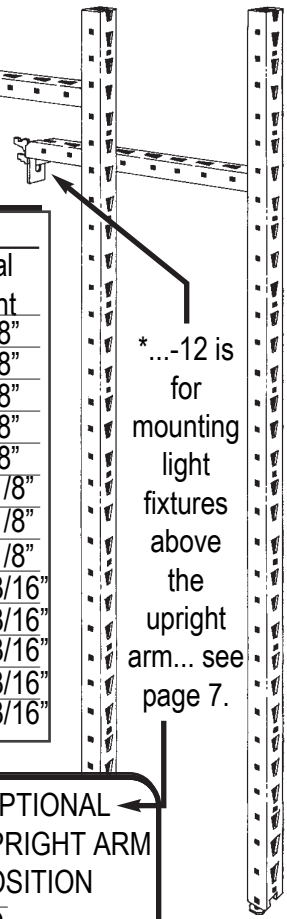

*OPTIONAL UPRIGHT ARM POSITION

UPRIGHT UPRIGHT
HYPERMAXI HEIGHT DEPTH

HMU □□□□-12

UPRIGHT UPRIGHT
DEPTH

H Y P E R M A X I

PARTS IDENTIFICATION

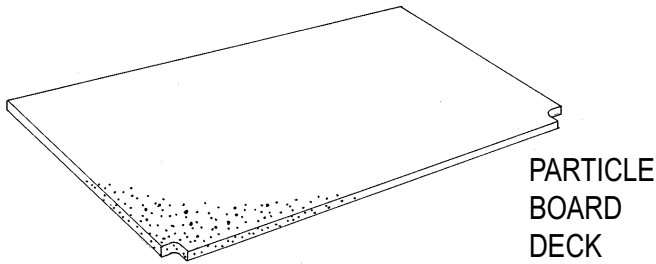

UPRIGHT SEALED = S
 HYPERMAXI DEPTH UNSEALED = U
 HMRDD□□□□-U
 REGULAR DUTY = RD BEAM
 HEAVY DUTY = HD LENGTH
 DECK

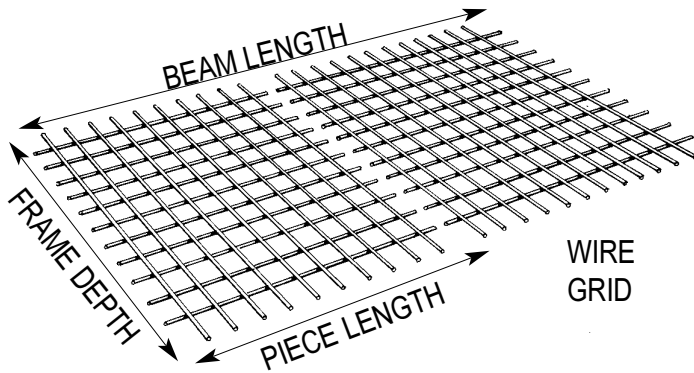

PARTICLE BOARD DECKS... DIMENSIONS...

UPRIGHT DEPTH	ACTUAL DEPTH	PIECE LENGTH	ACTUAL LENGTH
18"	18"	36"	35 17/32"
20"	20"	48"	47 17/32"
22"	22"	60"	59 17/32"
24"	24"	72"	71 17/32"
30"	30"	84"	83 17/32"
-	-	96"	95 17/32"

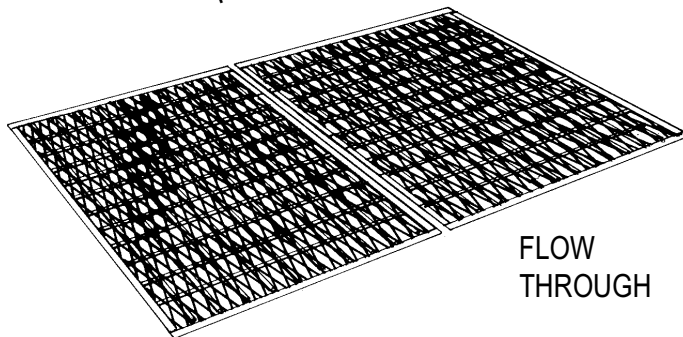

UPRIGHT GRID SIZE
 HYPERMAXI DEPTH ...3" O.C.
 HMWMS□□□□-3
 WIRE GRID BEAM
 DECK LENGTH

FLOW THROUGH UPRIGHT DEPTH
 FTHMD□□□□
 HYPERMAXI DECK BEAM LENGTH

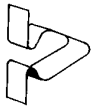

DART CLIP
 WDC-50
 ...pack of 50

HYPERMAXI
 CENTER
 SUPPORT ARM
 HMUSCA□□

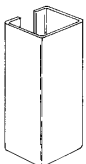
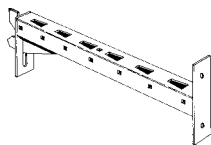

HYPERMAXI
 LEVELER COVER
 HMUCA
 ...6" x 2" x 2"

HYPERMAXI
 ATTACHMENT CLIP
 HMAAC-2
 ...two pack

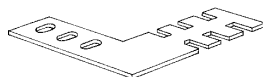

WIRE GRID DECKS AND FLOW THROUGH DECKS... DIMENSIONS...

UPRIGHT DEPTH	ACTUAL DEPTH	PIECE LENGTH	ACTUAL LENGTH
18"	17 3/4"	24"	23 3/4"
20"	19 3/4"	36"	35 3/4"
22"	21 3/4"	48"	47 3/4"
24"	23 3/4"	-	-
30"	29 3/4"	-	-

WIRE GRID AND FLOW THROUGH PIECE LENGTHS RUN PARALLEL TO BEAM LENGTH

BEAM LENGTH	COMBINATIONS OF PIECE LENGTHS	# OF DECK SUPPORTS
36"	36"	2
48"	48"	2
60"	24" plus 36"	4
72"	36" plus 36"	4
84"	36" plus 48"	4
96"	48" plus 48"	4

INSTALLATION INSTRUCTIONS

1

Run levelers on Hypermaxi uprights all the way up. Slide leveler cover, if used, approximately 6" up Hypermaxi upright and secure with tape.

2

If plastic upright end covers, UEC-□□, are used, they should not be installed at this point. If metal upright end covers, VC-□□, they should be installed at this point.

3

Hold Hypermaxi upright at an angle as shown and insert bracket into the sixth slot from the top of the fixture upright; if using HMU-□□□□-12 is used, insert into the twelfth slot down. The bottom of the Hypermaxi upright will pivot in toward base when bracket is properly engaged.

4

Pull down on the bracket arm, using your weight to properly seat bracket in upright.

5

Repeat steps 4-5 on opposite side of fixture if it is a gondola.

6

Insert screw as shown through fixture slotting and Hypermaxi upright bracket. Secure with washer and nut on other side.

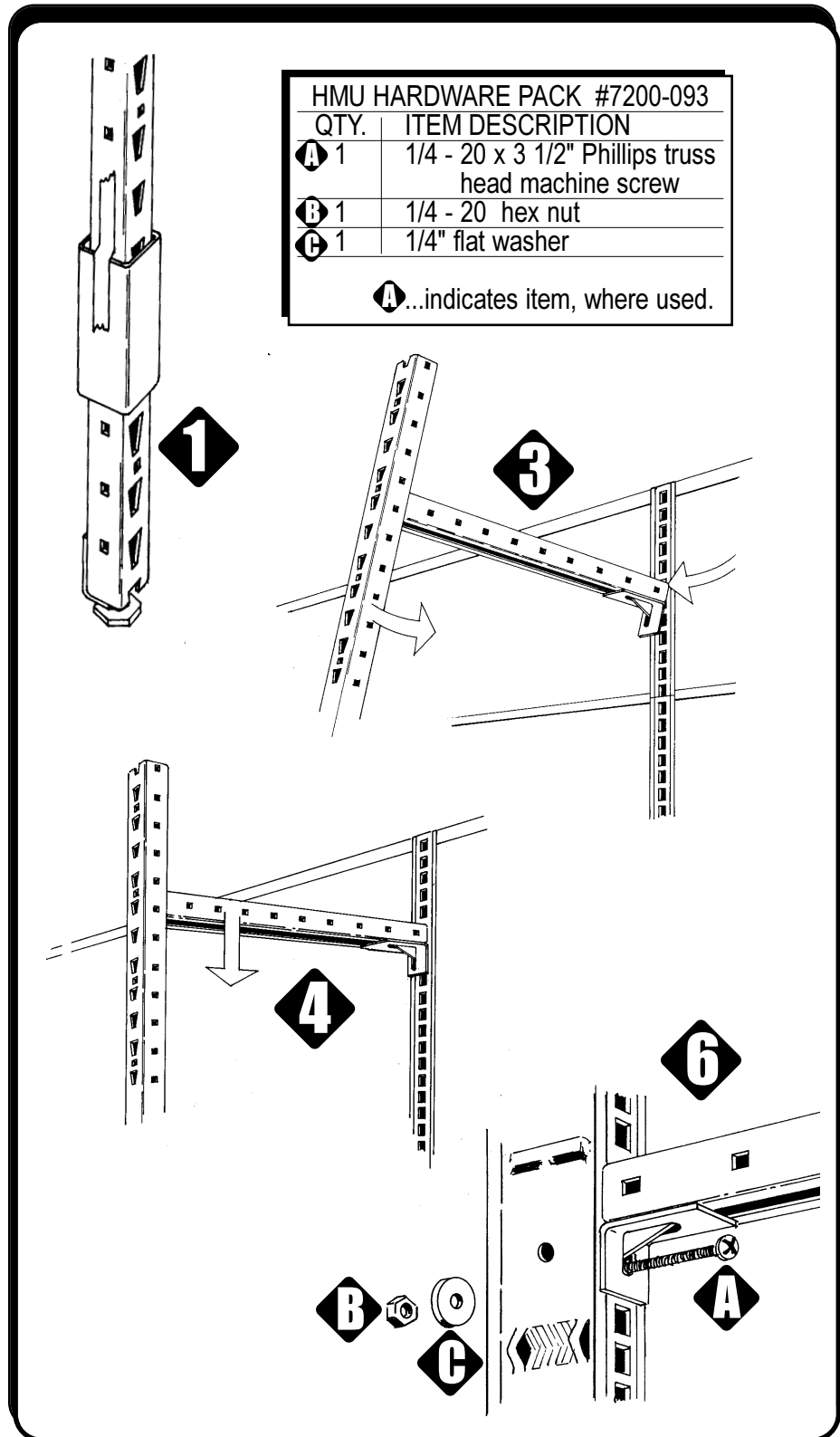

HMU HARDWARE PACK #7200-093	
QTY.	ITEM DESCRIPTION
A 1	1/4 - 20 x 3 1/2" Phillips truss head machine screw
B 1	1/4 - 20 hex nut
C 1	1/4" flat washer

A...indicates item, where used.

INSTALLATION INSTRUCTIONS

- 7** Run Hypermaxi upright levelers down to floor... untape leveler cover, if used, and slide cover down to floor.
- 8** Insert the attachment clip into Hypermaxi upright and rotate 90°.
- 9** Select required attachment clip positioning from the diagram below, then secure attachment clip to base shelf with fasteners in hardware pack shown below.
- 10** Install beams at required heights. For front and rear beam sizes and bracket shapes, refer to parts identification on page 2.
- 11** Press dart clips through beam bracket and upright on the under side of beam as shown, Insert one dart clip at each end of all beams.

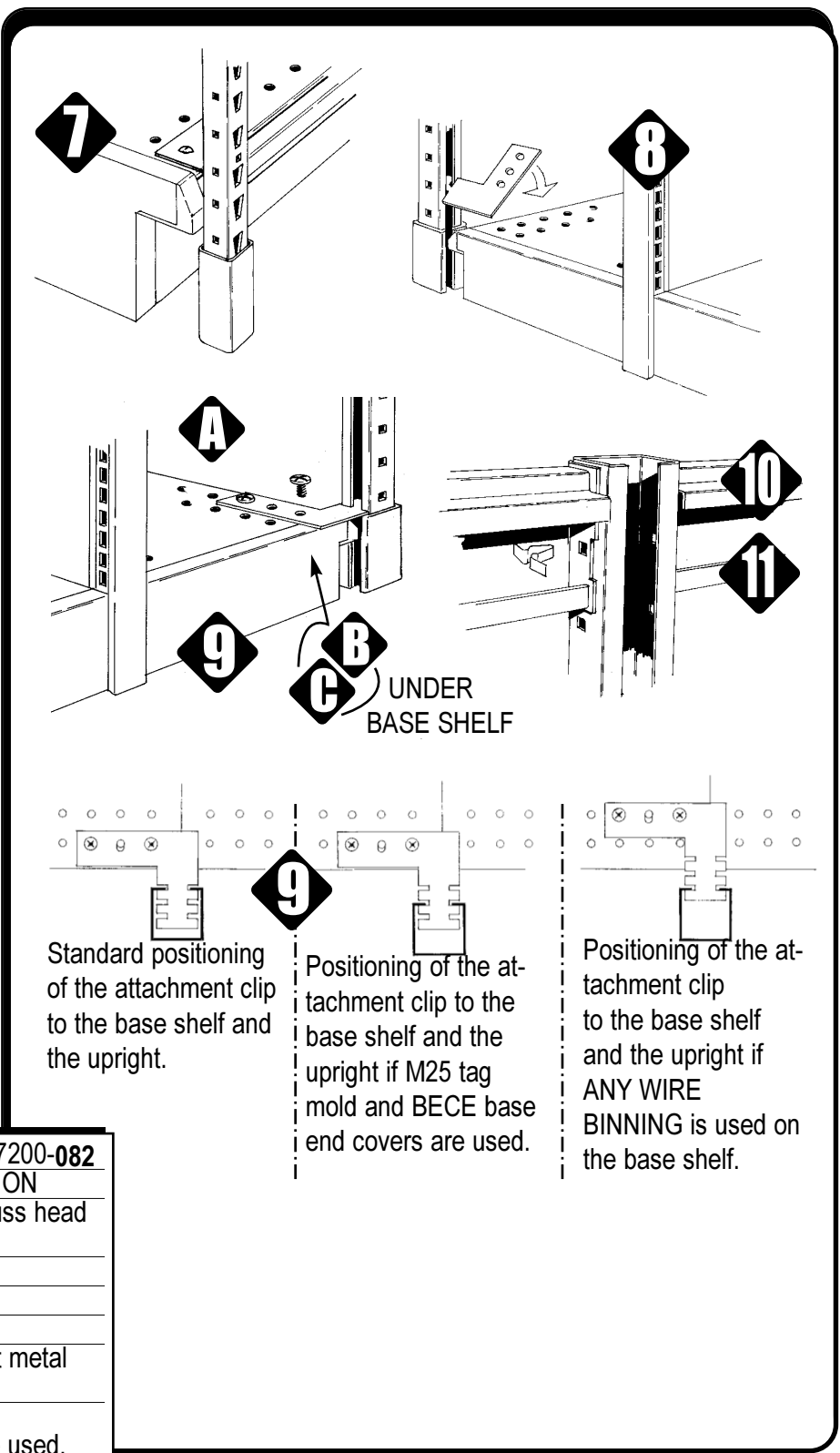

Standard positioning of the attachment clip to the base shelf and the upright.

Positioning of the attachment clip to the base shelf and the upright if M25 tag mold and BECE base end covers are used.

Positioning of the attachment clip to the base shelf and the upright if ANY WIRE BINNING is used on the base shelf.

HMAC-2 HARDWARE PACK #7200-082

QTY.	ITEM DESCRIPTION
A 4	1/4 - 20 x 1/2" Phillips truss head machine screw
B 4	1/4 - 20 hex nut
C 4	1/4" flat washer
D 4	1/4 - 20 lock washer
E 4	# 8 x 1/2" hex head sheet metal screw

A...indicates item, where used.

12

Holding the deck support at an angle to the beam, squeeze the open side and insert into the beam, then swing the free end around to the opposite beam, squeeze the open side and insert into the beam.

13

Squeeze the open side of the deck support at each end just inside the beam and rotate upwards as shown.

14

Correct installed position will look like diagram 14. See layout diagram for quantity of deck supports per beam length. Supports may be slid or tapped into locations as shown.

15

Lay the decks on the deck supports. The notches on the particle board decks are on the front edge to accommodate the Hypermaxi upright.

16

Trim the UEC-□□□, upright end covers, to fit over the Hypermaxi upright bracket prior to installing them.

17

Install upper shelves and accessories into the basic fixture upright.

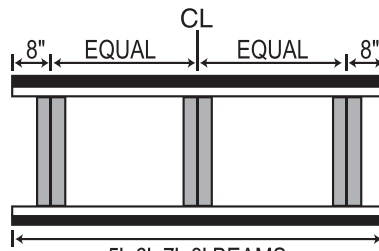

wood decks... three deck supports

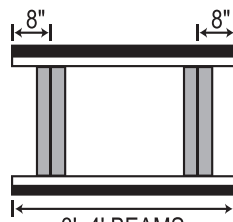
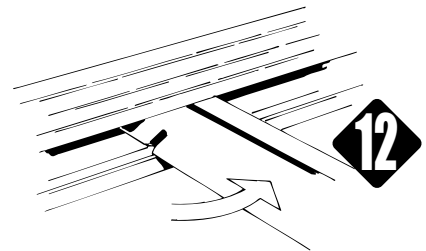

all decks... two deck supports

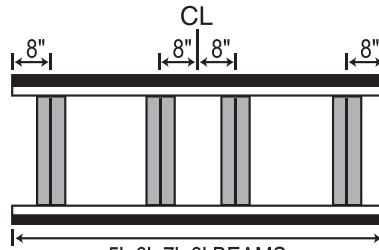
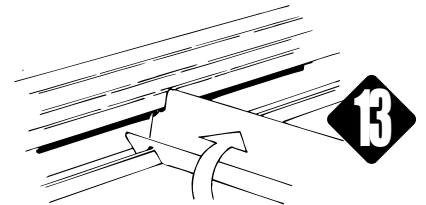

wire grid & flow through decks... four deck supports

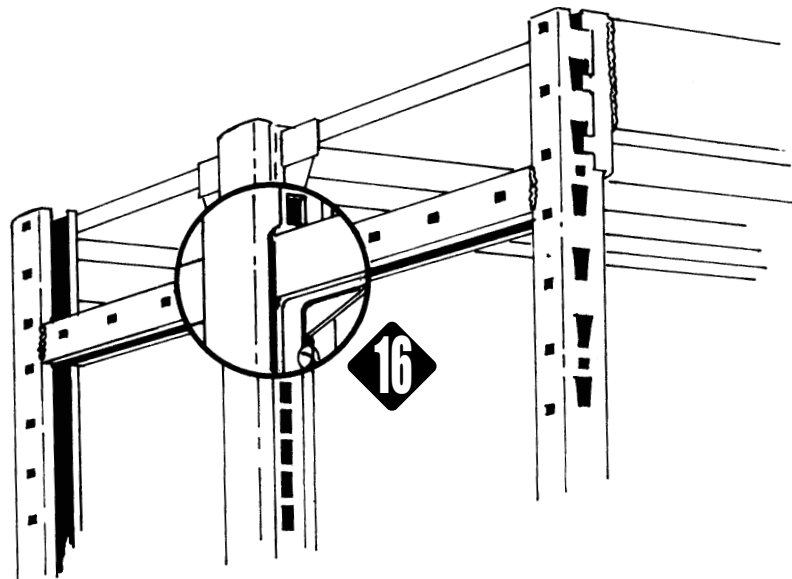
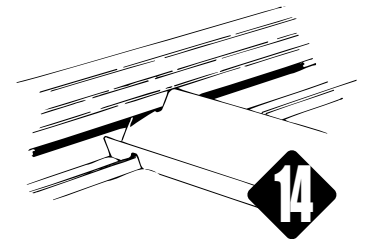

INSTALLATION OF EXTRAS

NOTE!

The Hypermaxi center support arm must be installed at the approximate midpoint of the Hypermaxi upright and above the installed upper shelves. If two support arms are used on an upright, they should be equally spaced.

18

Hold the center support arm at an angle as shown and insert bracket into the basic fixture upright and pull down on the bracket arm, using your weight to properly seat bracket in upright.

19

Pull outward on the Hypermaxi upright and swing the center support arm in behind the upright. Align the mounting plate holes with the upright slots and secure with the fasteners as shown.

20

There are two means of securing the light fixture to the deck support...the fasteners are provided for either one.

1. Use the self drilling Tek-2 screw, item D, as shown. This runs a slight risk of drilling into the interior wiring of the light fixture.

OR

2. Use the screw and nut, items B and C, as shown. This will require removing the light fixture cover.

21

Using the self-drilling screws, item E, secure the reflector to the light fixture as shown.

ASSEMBLY COMPLETE

CENTER SUPPORT ARM... HMUSAC-□□

QTY.	ITEM DESCRIPTION
A 3	1/4 - 20 x 2 1/2" round head machine screw
B 3	1/4 - 20 hex nut
C 6	1/4" flat washer
A	...indicates item, where used.

WS/HMLMK LIGHT MOUNTING KIT

QTY.	ITEM DESCRIPTION
D 4	wire shelf clip
E 4	#8-32 x 1/2" Phillips pan head machine screw
F 4	#8-32 x 1/2" hex/Keps nut
G 4	#8 x 1/2" Phillips pan head, Tek-2 sheet metal screw

QTY.	ITEM DESCRIPTION
H 3	#10 x 1/2" Phillips pan head, Tek-3
D	...indicates item, where used.

LIGHT MOUNTING KIT/REFLECTOR... HMU-□□LR

