

MAGNUM

S

MODEL

INSTALLATION

INSTRUCTIONS

www.  .com
BOAT LIFTS
sales@lunmar.com
3715 Hwy. 27 South • Sulphur, LA 70665
(337) 558-7200 • (800) 965-8544
Fax (337) 558-7202

Prior to installation:

- a). To insure that the lift will operate properly, adequate electricity should be available. Electricity will also be needed to install the lift.
- b). Insure that the pilings are at least 18" high above the deck of the pier.
- c). The lift pilings should be driven in the ground to refusal. Otherwise the weight of the boat will sink the piles.
- d). If existing piles are to be used, insure they are not cracked or show any signs of decay.
- e). obtain any locally required permits.

DO NOT USE ANY POWER TOOLS WHILE STANDING IN THE WATER. IF ELECTRICITY MUST BE USED NEAR THE WATER, INSURE THAT THE CIRCUIT IS PROTECTED BY A GROUND FAULT INTERRUPTER.

- 1). The standard Magnum 4 pile lifts are shipped to be mounted in either the Inside/Inside or Outside/Outside configuration. The supplied bunks are 14 feet long for the 8,000 lb. and 10,000 lb. and 16 feet for the 12,500 lb. When determining which configuration to use, you must consider the length of the bunks. For example a fore and aft pile spacing of 13 feet will be too long to go outside/outside on a 10,000 lb. lift. You must go Inside/Inside. Ideally the cradle should be 10 feet to 12 feet long for the 8,000 lb. and 10,000 lb. and 12 feet to 14 feet for the 12,500 lb. lift. (fig. 4a)
- 2). The cradle travels up and down next to the pilings. If the pilings are part of the dock cut out the deck boards as shown in figure 004b.
- 3). Mount the spacer block (fig. 003 #34) in accordance with fig. 004c. Before mounting the block, determine how high you want the cradle to come. We recommend that the middle bolt be 10 inches above the deck boards. This will allow the cradle to come up just above the deck when the lift is in the full up position. The spacer blocks should always be used. They give the cradle extra clearance between the pilings on the dock side. It may be necessary to shave or notch the pilings with a chainsaw or a hatchet to give the blocks a 3/8 of an inch lean away from the piling at the top. Attach the block with 2 each 40p nails.
- 4) Mount the pile mount as shown in figure 003 using two 5/8 inch carriage bolts. The middle bolt hole should be 10" above the deck. There is enough cable supplied to lower the cradle 9 feet from sheave S1 (fig. 005).
- 5). Mount the corresponding back covers onto the gear plates. There is one long cord motor and one short cord motor. The long cord should go to the bow and the short cord to the stern. Mount the motors, pulleys and belts onto the gear plate (figure 005) . Place the gear plates onto the cable drums. Install the spacer sleeves, motor anchors and the 1/2 inch washer/shim (39). The shim is important and must be placed between the motor anchors and the pile mounts.
- 6). Bring the long cord switch to the stern pile mount. There should be enough wire to run under the pier and back to the stern portion of the lift. Run the long cord switch into the slot of the short cord back plate so that both switches are in the same location. (figure 007). Attach the front covers to the back covers (fig.007). Mount the switches as per figure 007 on the most convenient side of the front cover (figure 007). Use the 2 tie wraps to secure any loose wires inside the cover. If one or both of the motors are running in the wrong direction you must change the wiring inside of the motor. This is easily done. Remove the access plate from the end of the motor and follow the directions on the motors data plate.
- 7). Mount the outside hangers (figure 002 # 10) as shown in figure 004b. The mounting height is found by measuring the distance from sheave S1 to the water

and adding 5 inches. This is the drilling height mark. When mounting the outside hanger, it is important that the length of the lifting beam be equal to the distance between the outside hanger sheave and sheave S1. (Figure 011a). The outside hanger can be turned towards the dock to accomplish this. However the outside hanger cannot be turned away from the dock, as this will pull the lift beam into the piling. If the beam is too long, it may be cut to size and reassembled as in figure 009A.

- 8). Match the left lifting beam to the left pile mount and suspend the lifting beams using chains or a scaffolding. Upon installation the outside of the lift should be 2" to 3" higher than the dockside. Over time this will level out by itself. Route the cables as shown in figures 11A, 11B and 11C. The longer cables run to the outside and the shorter cables to the inside. Attach the cables to their anchor points on the lifting beams. From the drum, even both lengths of cable so that equal amounts of cable will be wrapped onto both sides of the drum. Secure the cable clamps to the cable tightly. Slip the bitter ends back into the end of the drum, then pull on each cable where it exits the drum. This will eliminate any exposed ends of the cable. Wind the cable onto the drum keeping it tight and neat without criss-crossing. If the lift is not level when raised, shorten or lengthen the cable 2 inches for every inch low or high until it is 2" to 3" high on the outside.
- 9). For Vee bottom boats attach the bunks vertically as in figure 013. Pontoon or catamaran hulls as in figure 015. Please note that the boat must be closer to the GEAR side of the lift than to the outside of the lift to function properly. Position the guide poles and bunks in their proper positions as in figure 013. The bow and stern pads are optional. Cut the catwalk angle, drill and bolt as in figure 010.

IMPORTANT

A GOOD HEAVY GREASE MUST BE APPLIED TO THE GEAR UNITS PRIOR TO LIFTING A BOAT. THE GREASE THAT COMES ON THE GEARS FOR SHIPMENT, IS NOT ENOUGH TO INSURE PROPER LUBRICATION. IT IS BEST TO APPLY THE GREASE WHILE THE UNITS ARE RUNNING. UPON LIFTING THE BOAT, IF ANY GRINDING OR FINE POWDER IS OBSERVED COMING FROM THE WORM GEAR, REAPPLY THE GREASE. AFTER THE GEARS HAVE SEATED, ONLY ANNUAL LUBRICATION IS REQUIRED.

- 10). When fitting the boat, only about 2' -3' of hull extends beyond the stern lifting beam, the remainder is off the bow. The bunks should contact the hull for at least 2/3 of the way down the bunk. Carpet and install the bow and stern pads if the hull is coming in contact with the lifting beams. Fit the boat as shown in figures 014 and 015.

**"S" MODEL LIFTS: 8,000 LB, 10,000 LB, 12,500 LB
PARTS LIST**

NO.	ITEM DESCRIPTION	QTY
1	6" x 12# x 13' LIFT BEAMS/12,500# 8" x 13# x 15" LIFT BEAMS	2
2	2 1/2" x 2 1/2" x 12' CATWALK ANGLE	1
3	GUIDE POLE STANTIONS	4
4	2" PVC PIPE 8' LENGTHS	4
5	GUIDE POLE PLATES (CLAMPS)	8
6	1/2" BORE SHEAVES (8,000 LB, 10,000 LB)	8
7	1/2" BORE SHEAVES WITH STAINLESS BUSHING (10,000 LB)	6
8	OUTSIDE BEAM ADAPTERS	2PR
9	INSIDE BEAM ADAPTERS	1PR
10	OUTSIDE PILING SHEAVE HANGERS	2
11	PILE MOUNTS WITH SHEAVES AND BEARINGS INSTALLED	2
12	MOTOR ANCHORS	2
13	GEAR PLATES	2
14	8000# 5 1/4" PULLIES/10,000# 6" PULLIES/12,500# 8"	2
15	8000# 4L260 BELTS/10,000# 4L280 BELTS/12,500# 4L320	2
16	SPACER SLEEVES	2
17	SPOOL SHIELDS	2
18	CABLES (8000#-1/4"/10,000, 12,500-5/16") (2 LONG + 2 SHORT-WITH EYELETS)	4
19	3/4 HP MOTOR WITH LONG CORD	1
20	3/4 HP MOTOR WITH SHORT CORD	1
21	HINGED COVERS	2
22	TIMBER RUNNER BRACKETS	4PR
23	ROLLS CARPET 5" WIDE x 14' LONG	2
24	CARPET PIECES 6" x 24" (BOW AND STERN PADS)	2
25	PVC GUIDE POLE CAPS	4
HARDWARE BAGS (PART NUMBERS NOT SHOWN ON DRAWINGS)		
26	COVER HARDWARE PACK	1
27	GUIDE POLE PACK	1
28	TIMBER RUNNER PACK	1
29	PILE MOUNT ATTACHING PACKAGE-WITH CABLE CLAMPS	1
30	FLAT CATWALK PACK	1

"S" MODEL LIFTS: 8,000 LB, 10,000 LB, 12,500 LB**OPTIONAL WOOD**

NO.	ITEM DESCRIPTION	QTY
31	3" x 10" x 14' CCA TIMBERS FOR BUNKS	2
32	2" x 10" x 16' CCA BOARD FOR WALKWAY	1
33	2" x 4" x 22" FOR PADS	2
34	3" x 6" x 24" FOR SPACER BLOCKS	2

GALVANIZED

35	3/8" PLAIN NUT	10
36	1/2" PLAIN NUT	28
37	5/8" PLAIN NUT	4
38	3/4" PLAIN NUT	2
39	1/2" WASHER	14
40	5/8" WASHER	6
41	3/4" WASHER	2
42	3/8" x 1" HEX	2
43	1/2" x 1 1/2" HEX	20
44	1/2" x 5 1/2" HEX	8
45	3/4" x 12" HEX	2
46	3/8" x 3 1/2" CARRIAGE	8
47	3/8" x 7" CARRIAGE (NOT USED)	0
48	3/8" x 9" CARRIAGE (NOT USED)	0
49	5/8" x 14" BUTTON	4
50	5/8" x 14" U-BOLT (NOT USED)	0

STAINLESS

51	5/16" PLAIN NUT	9
52	1/2" LOCKNUT	8
53	1/2" WASHER	16
54	1/2" x 4" HEX	2
55	1/2" x 3" HEX	2
56	1/2" x 6" CNTR SINK	2
57	1/2" x 4 1/2" HEX	2
58	5/16" x 2 1/2" CARRIAGE	9
59	5/16" x 1" HEX BOLT	4
60	5/16" FLAT WASHER	4
61	5/16" LOCKNUT	4

GENERAL NOTES:

⚠ IMPORTANT—PILINGS SHOULD BE SECURELY ANCHORED TO A SEAWALL OR INTEGRATED INTO A DOCK.

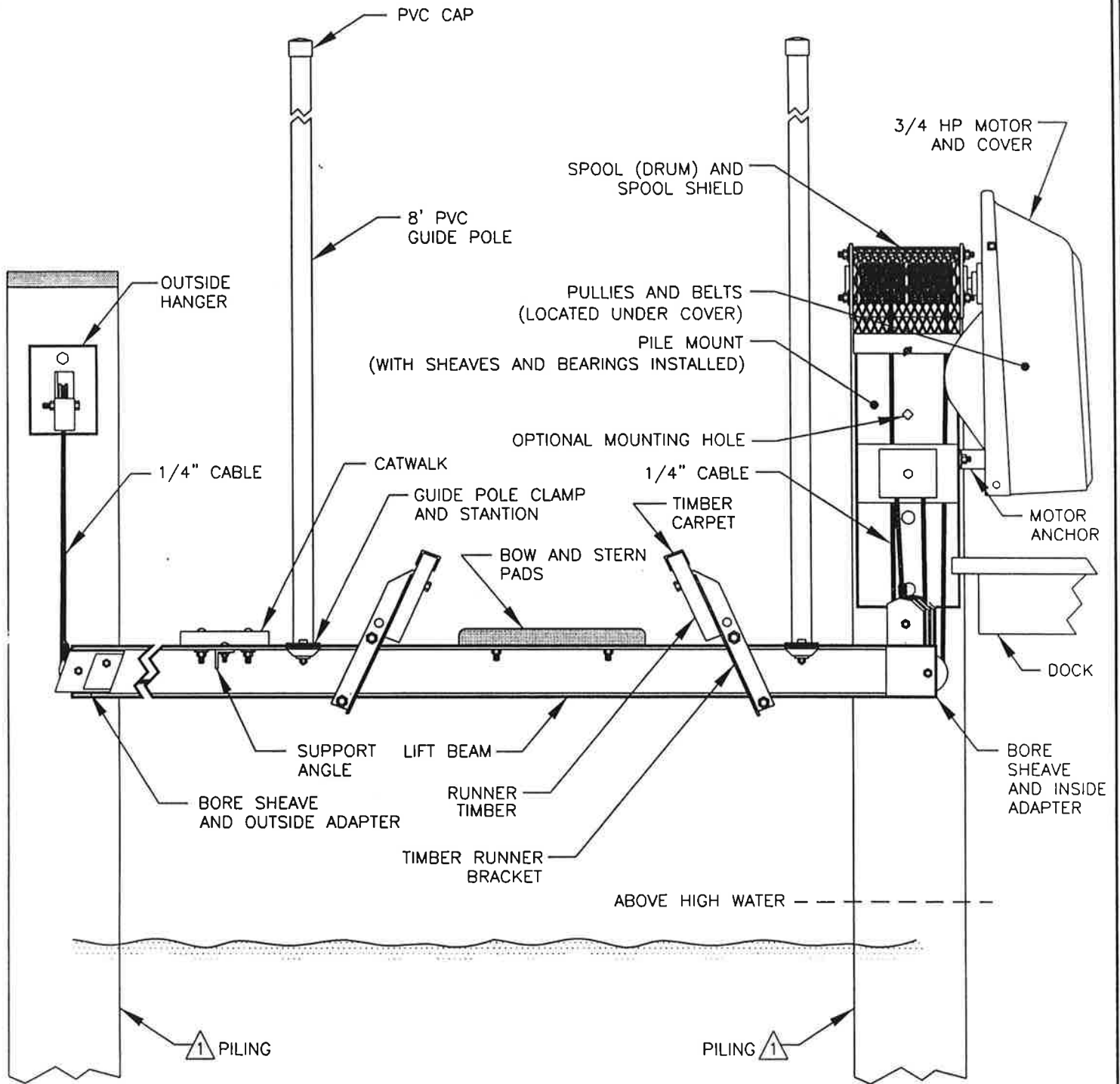

Project: "S" Model Assy Drawing Part Names (Piling Mount)		
No.: 001	Revision Date:	
Scale: None	Date: 11-03-00	Sheet: 1 of 1

GENERAL NOTES:

1. FOR LIST OF MATERIALS RELATED TO PART NUMBERS, SEE PARTS LIST.

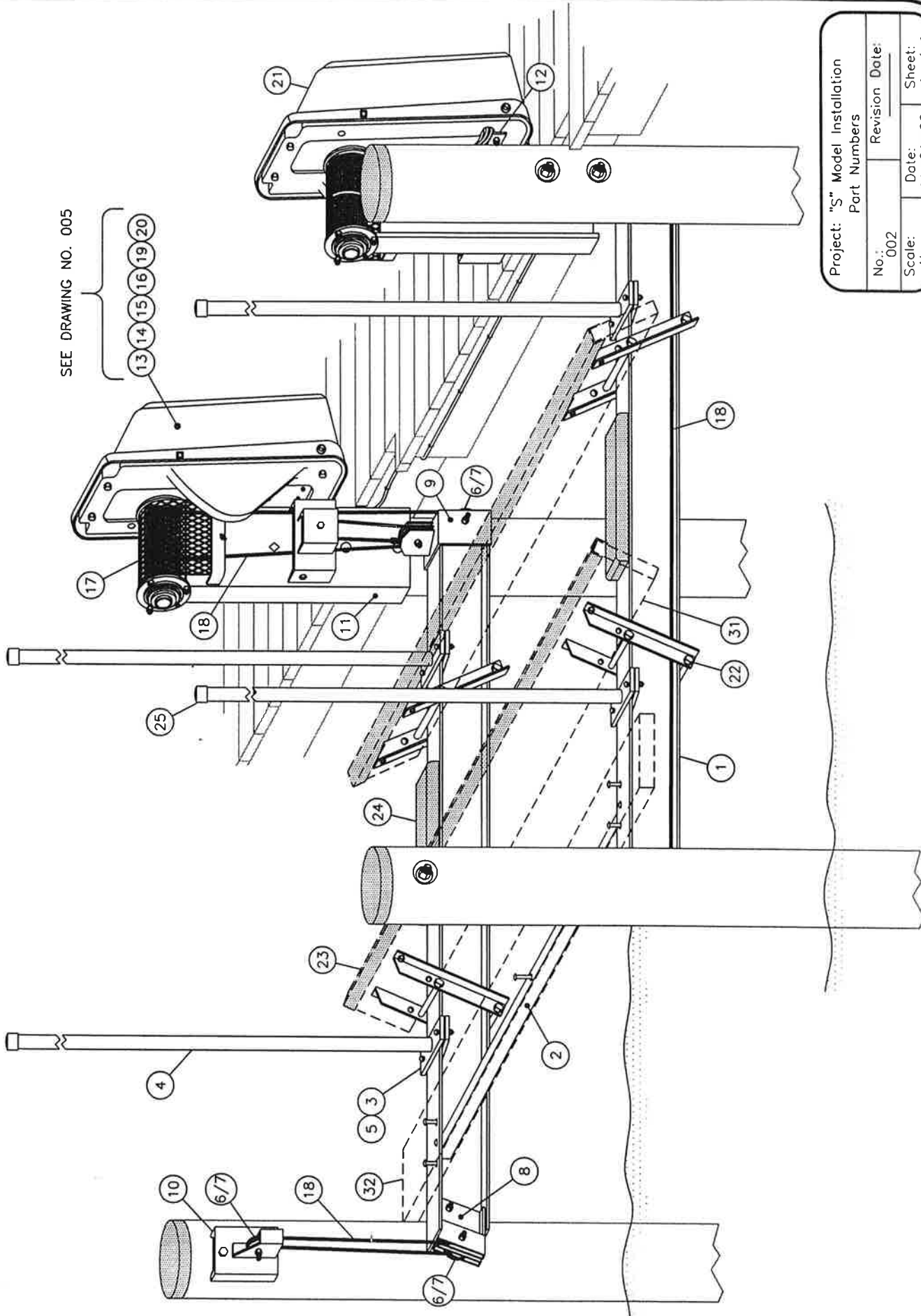

Project: "S" Model Installation	
Part Numbers	
No.: 002	Revision Date:
Scale: None	Date: 11-21-00
	Sheet: 1 of 1

GENERAL NOTES:

1. FOR LIST OF MATERIALS RELATED TO PART NUMBERS, SEE PARTS LIST.

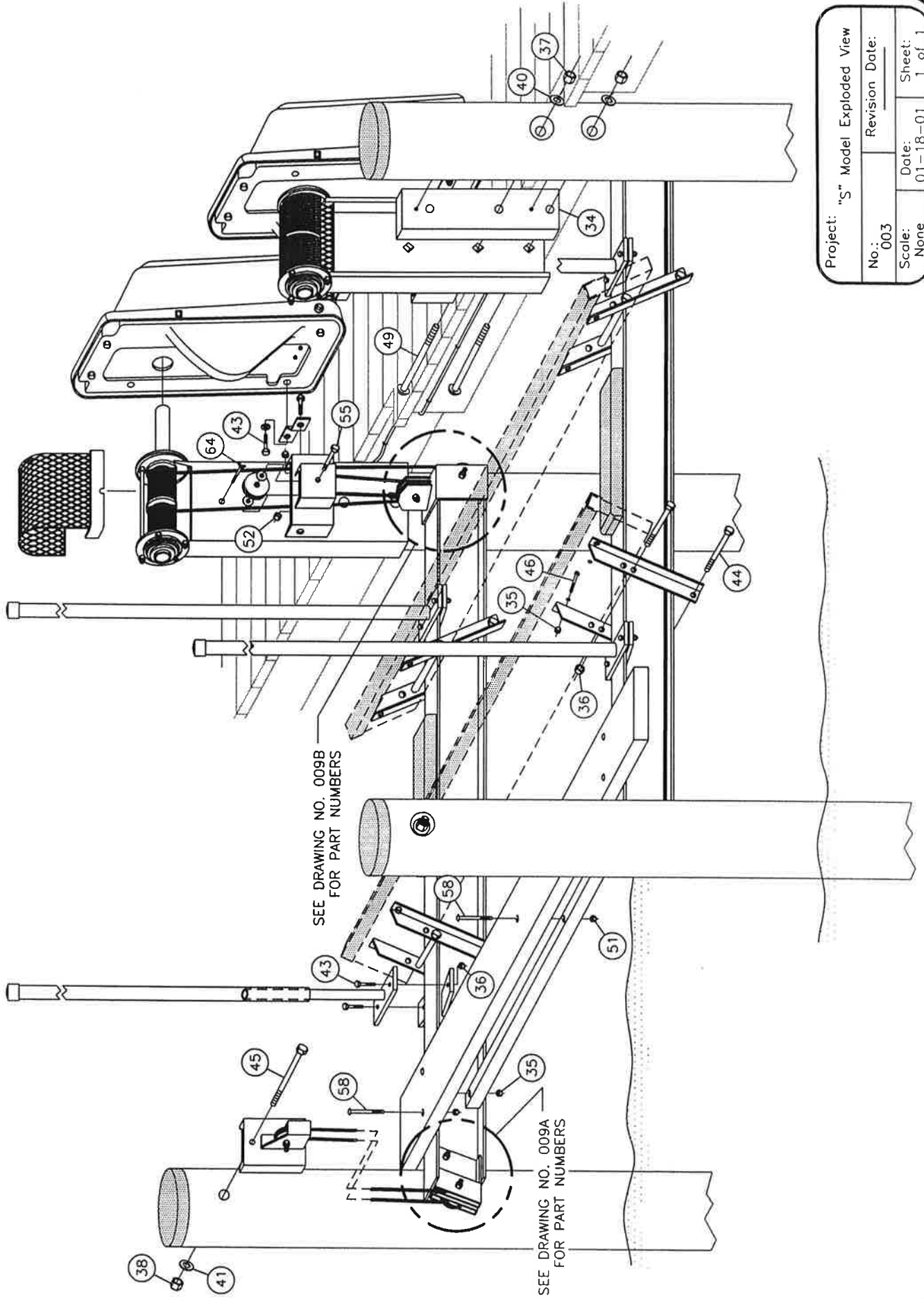

Project: "S" Model Exploded View

No.: 003 Revision Date:

Scale: None Date: 01-18-01 Sheet: 1 of 1

GENERAL NOTES:

1. DETERMINE WHICH SIDES OF THE PIER PILINGS WILL GIVE THE LIFT A FORE AND AFT SPAN OF 10' TO 13'. THE LIFT CAN BE MOUNTED WITH BOTH PILE MOUNTS FACING ONE ANOTHER OR IN OPPOSITE DIRECTIONS. A SPAN GREATER THAN 13' IS TOO LONG TO ALLOW THE BUNKS TO BE ATTACHED TO THE MAIN BEAMS. IF A LONGER SPAN IS UNAVOIDABLE, LONGER BUNKS ARE AVAILABLE UPON REQUEST.

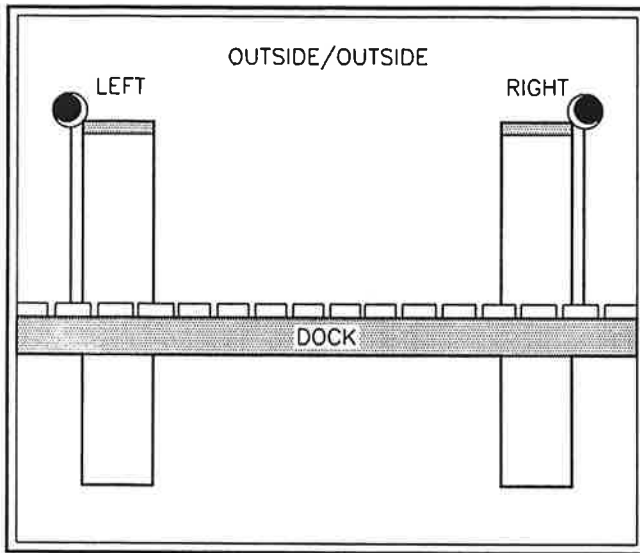

SIDE VIEW

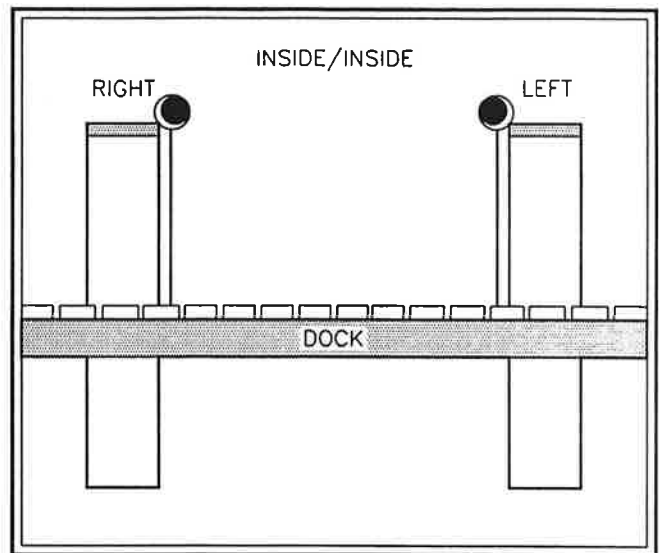

SIDE VIEW

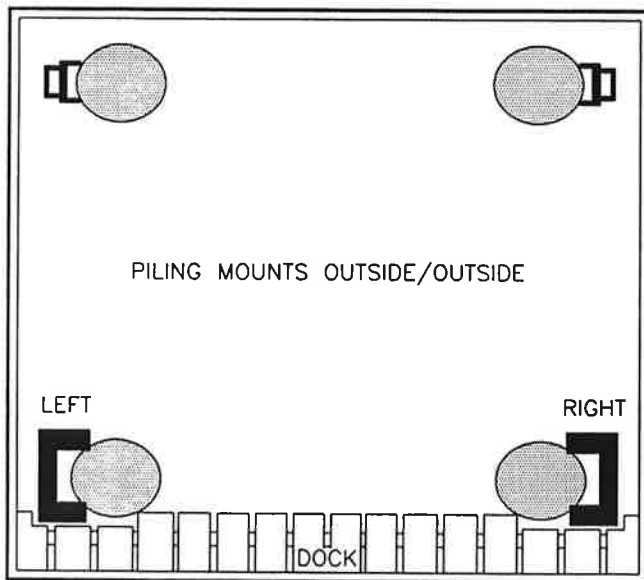

TOP VIEW

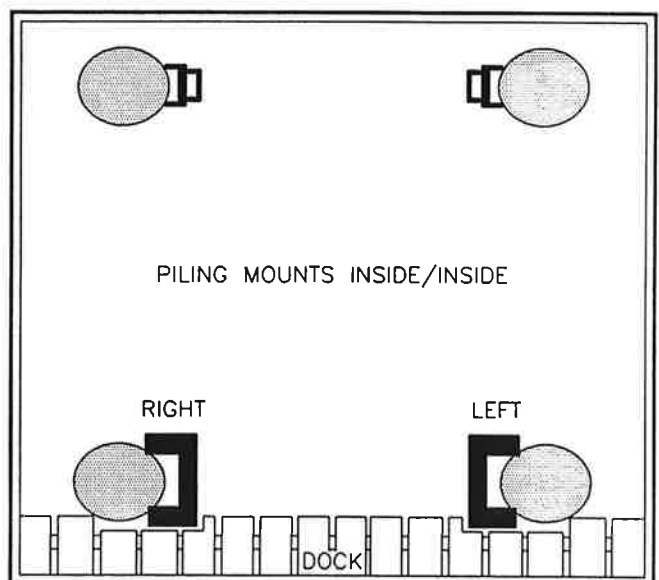

TOP VIEW

DIAGRAM 1

Project: Pile Mount Positioning		
No.: 004A	Revision Date:	
Scale: None	Date: 11-03-00	Sheet: 1 of 3

GENERAL NOTES:

1. IF THE PILING ARE RECESSED INTO THE DECK OF THE PIER, AN OPENING MUST BE MADE TO ALLOW A FREE, UNOBSTRUCTED PATH FOR THE LIFT. THE OPENING SHOULD RUN PARALLEL TO THE PIER STRINGERS FOR A DISTANCE OF 10", THEN TURN 90° TOWARD THE MOORING PILES AND CONTINUING ON TO THE END OF THE DECK BOARDS.

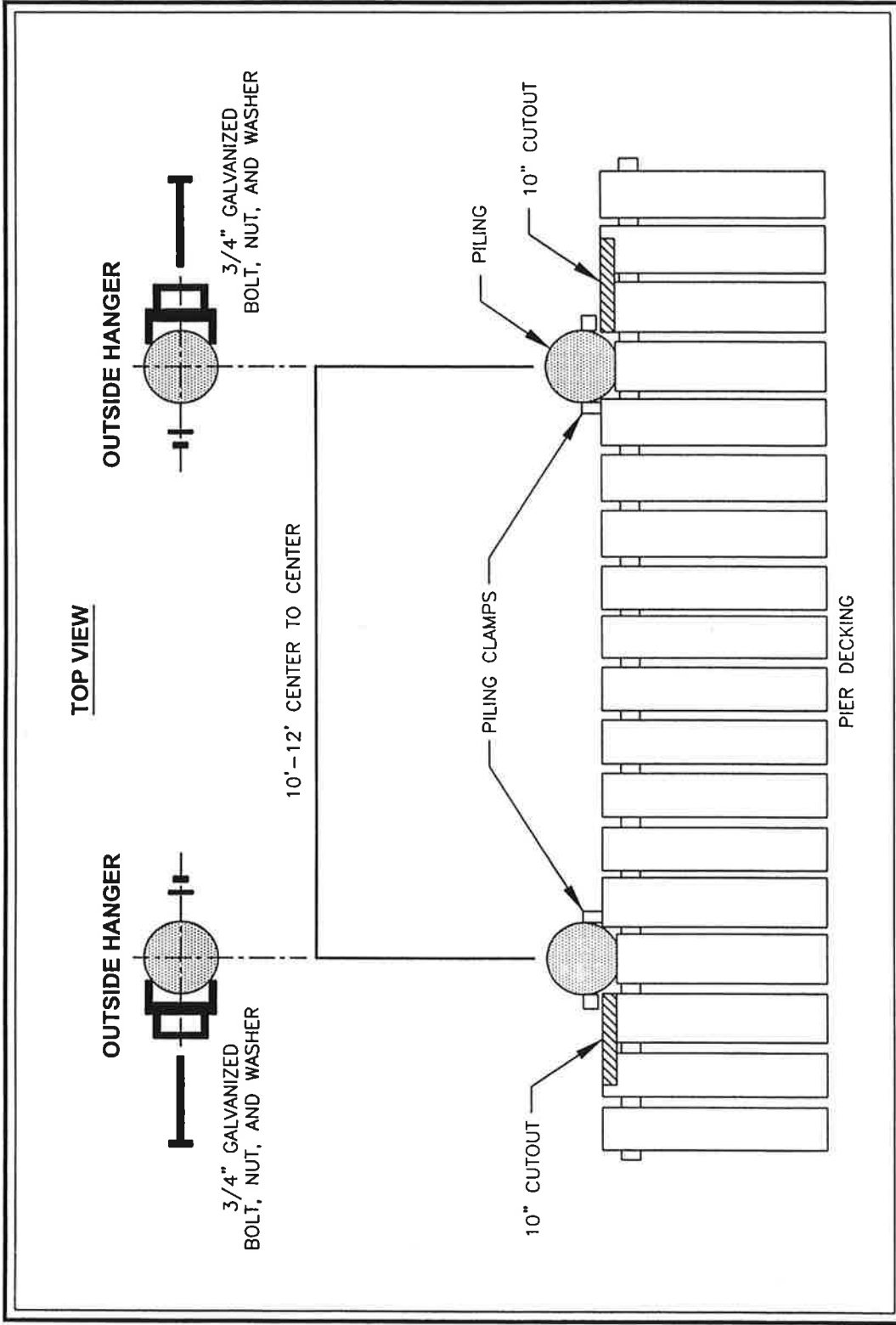

DIAGRAM 2

Project: Pile Mount Dimensions			
No.:	004B	Revision	Date:
Scale:	None	Date:	11-03-00
Sheet:		2 of 3	

GENERAL NOTES:

1. TOO MUCH OR TOO LITTLE 'LEAN' WILL ADVERSLY AFFECT THE OPERATION OF THE LIFT.
THERE SHOULD BE 3/8" LEAN IN TWO FEET OVERALL LENGTH.
2. SPACER BLOCK IS ATTACHED TO PILING WITH TWO 60p NAILS.
3. FOR LIST OF MATERIALS RELATED TO PART NUMBERS, SEE PARTS LIST.

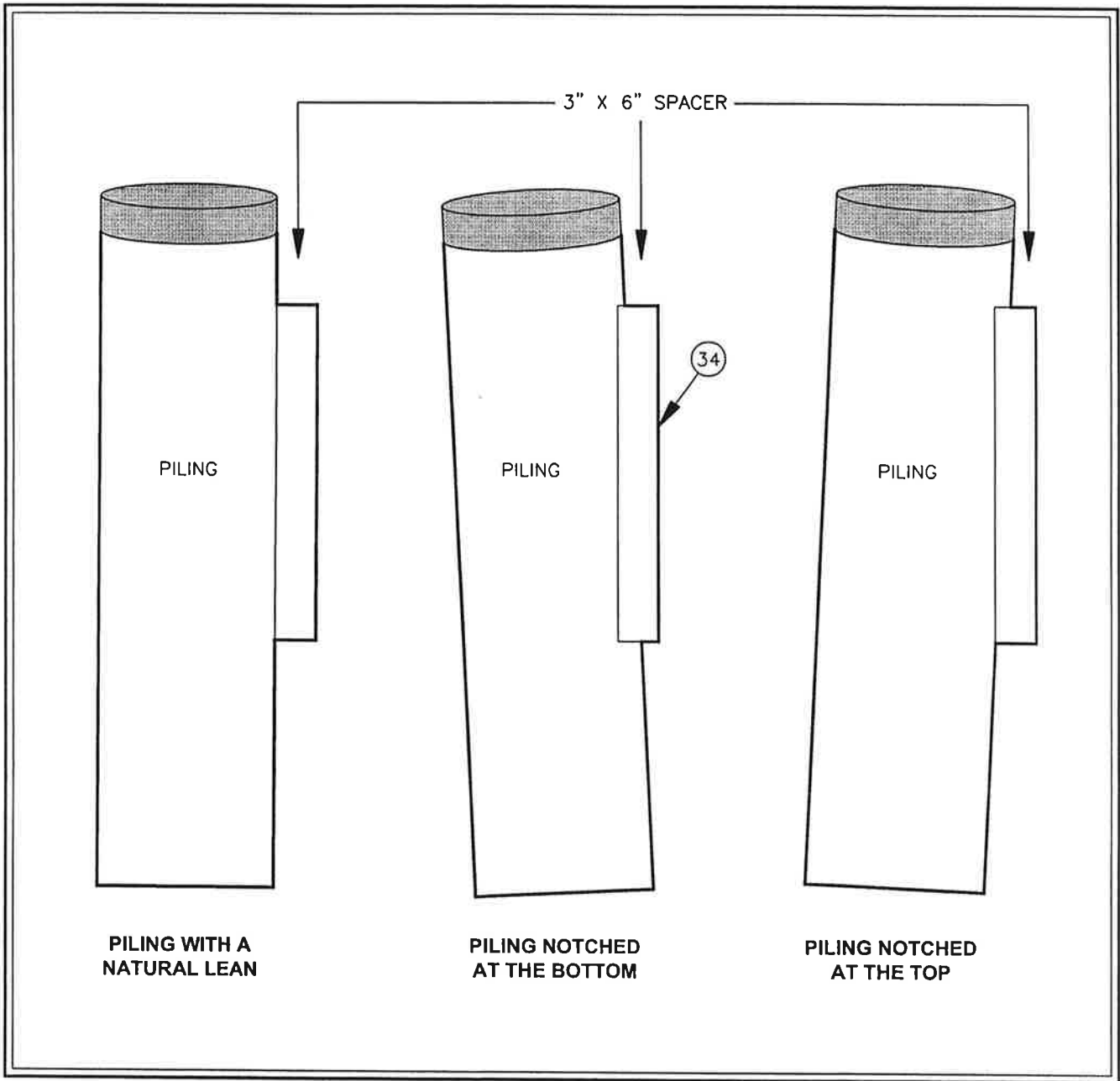

DIAGRAM 3

Project: Piling Lean And Spacer Block Attachment		
No.: 004C	Revision Date:	
Scale: None	Date: 11-03-00	Sheet: 3 of 3

GENERAL NOTES:

1. *CAUTION: INSTALL ONLY THE HARDENED BOLT SUPPLIED WITH THE GEAR ASSEMBLY. DO NOT USE ANY OTHER BOLT IN THIS LOCATION.

2. FOR LIST OF MATERIALS RELATED TO PART NUMBERS, SEE PARTS LIST.

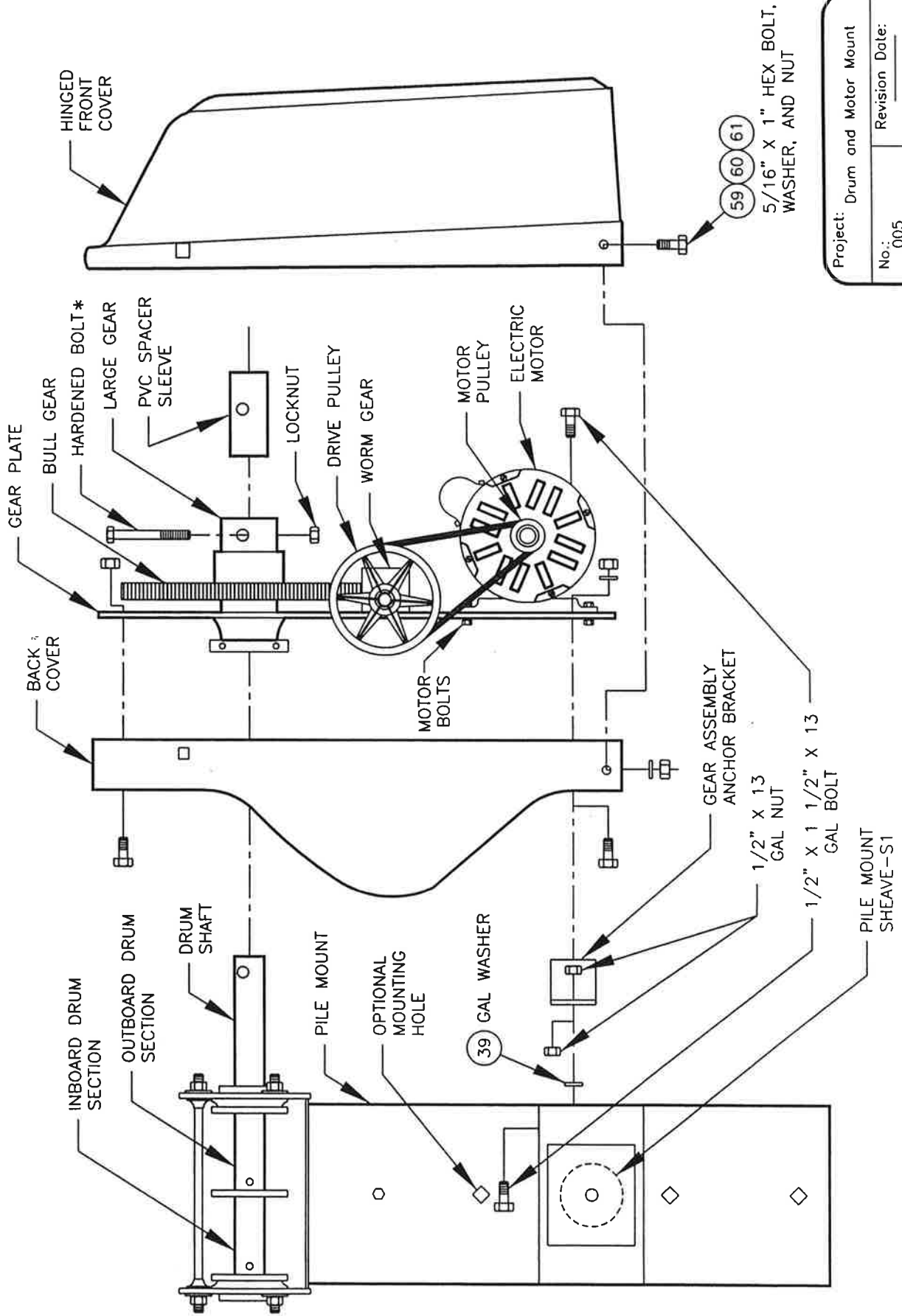

59 60 61
5/16" X 1" HEX BOLT,
WASHER, AND NUT

Project: Drum and Motor Mount	
No.: 005	Revision Date:
Scale: None	Date: 12-13-00
	Sheet: 1 of 1

GENERAL NOTES:

1. FOR A DETAIL DRAWING OF VIEW CALLED OUT, GO TO SPECIFIED DRAWING.

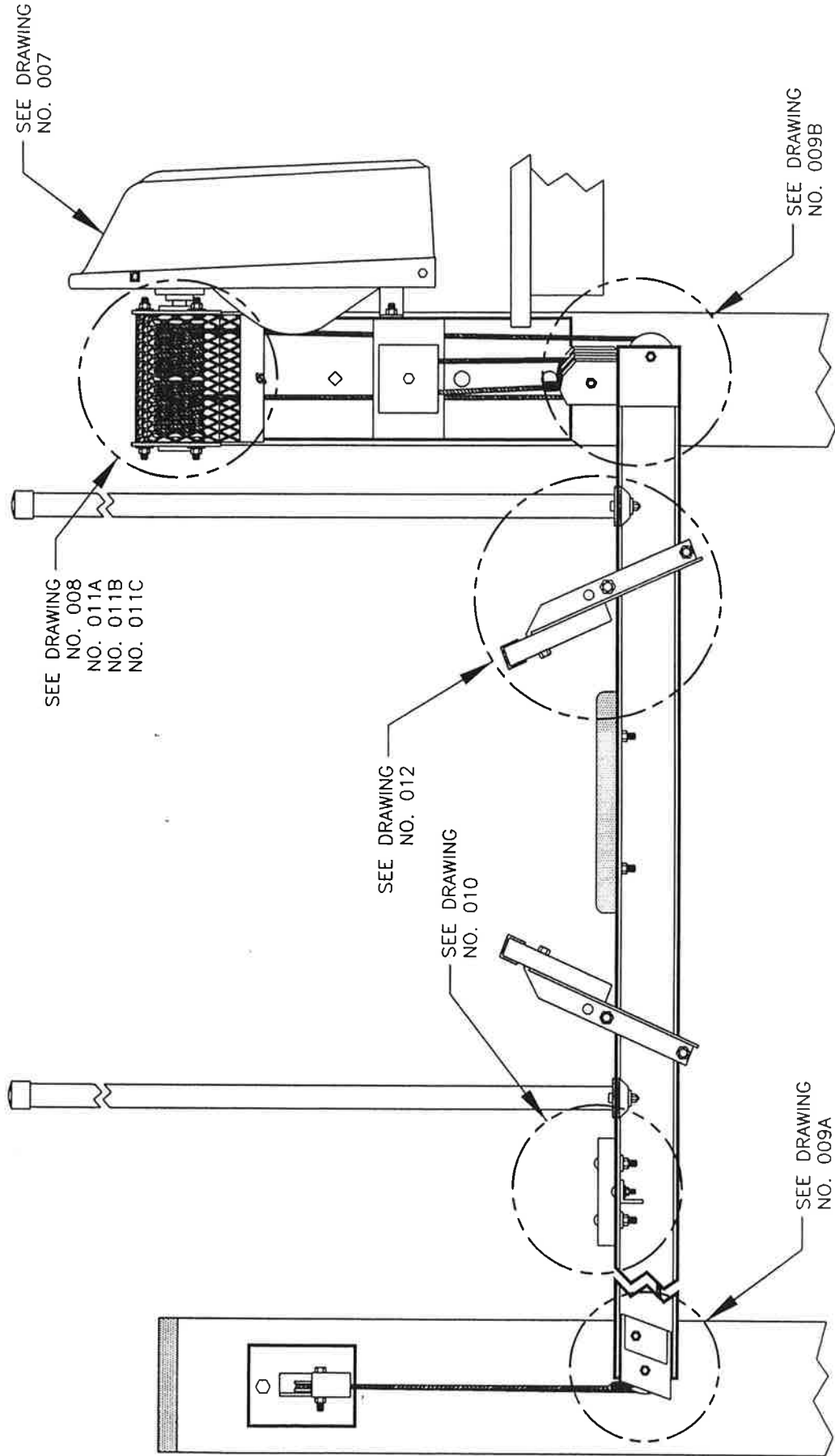

Project: Key To Detail Drawings

No.: 006	Revision Date:
Scale: None	Date: 07-20-00
	Sheet: 1 of 1

GENERAL NOTES:

1. THE CONTROL SWITCH SHOULD ALWAYS BE MOUNTED AT THE AFT END OF THE LIFT.
2. USE CABLE TIES (PART NUMBER 62) TO SECURE THE CONTROL WIRES INSIDE THE COVER.

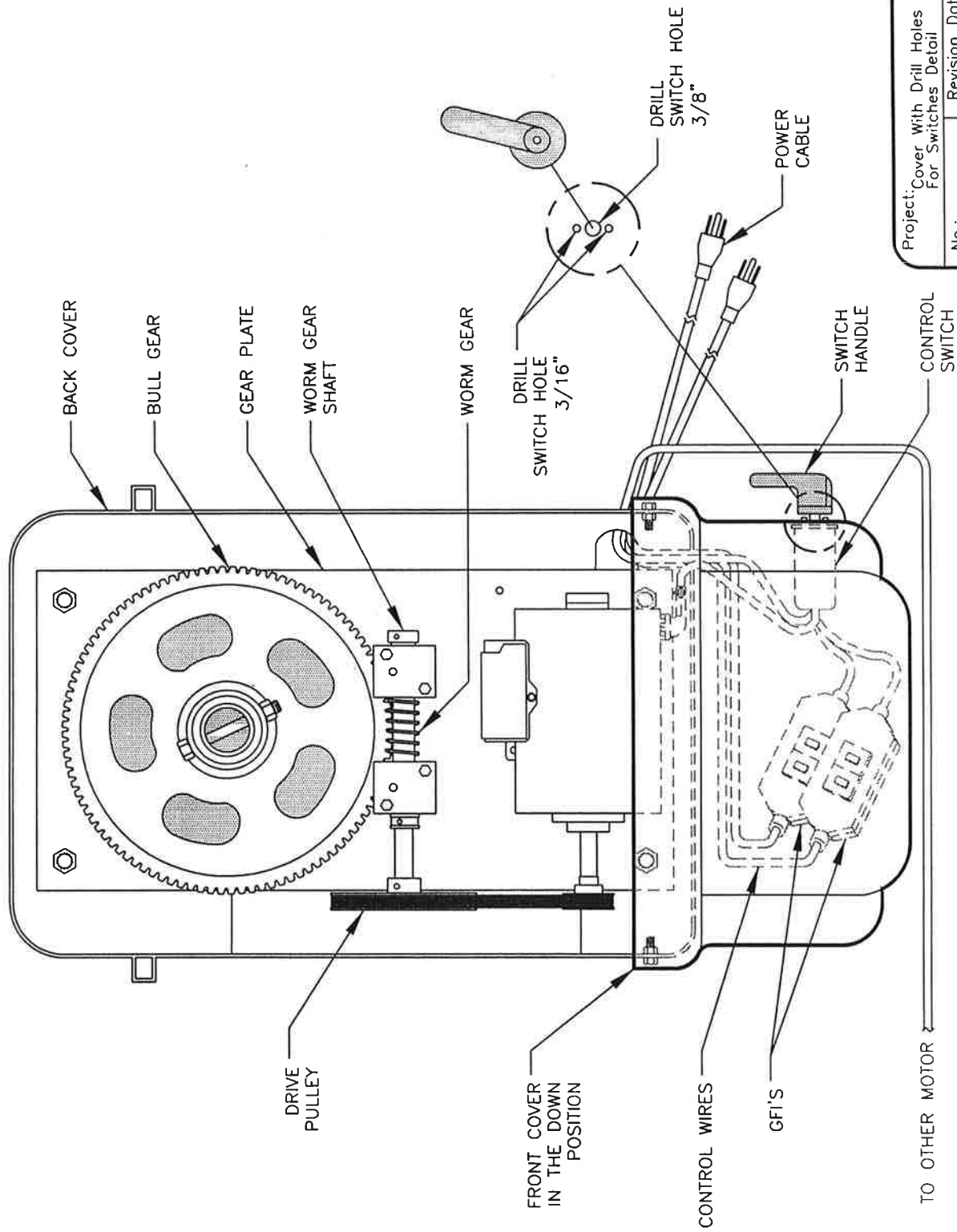

MOTOR HOUSING - FRONT VIEW

(COVER DOWN)

Project: Cover With Drill Holes For Switches Detail		Revision Date:	
No: 007	Date: 12-12-00	Sheet: 1	of 1
Scale: None			

GENERAL NOTES:

1. FOR LIST OF MATERIALS RELATED TO PART NUMBERS, SEE PARTS LIST.

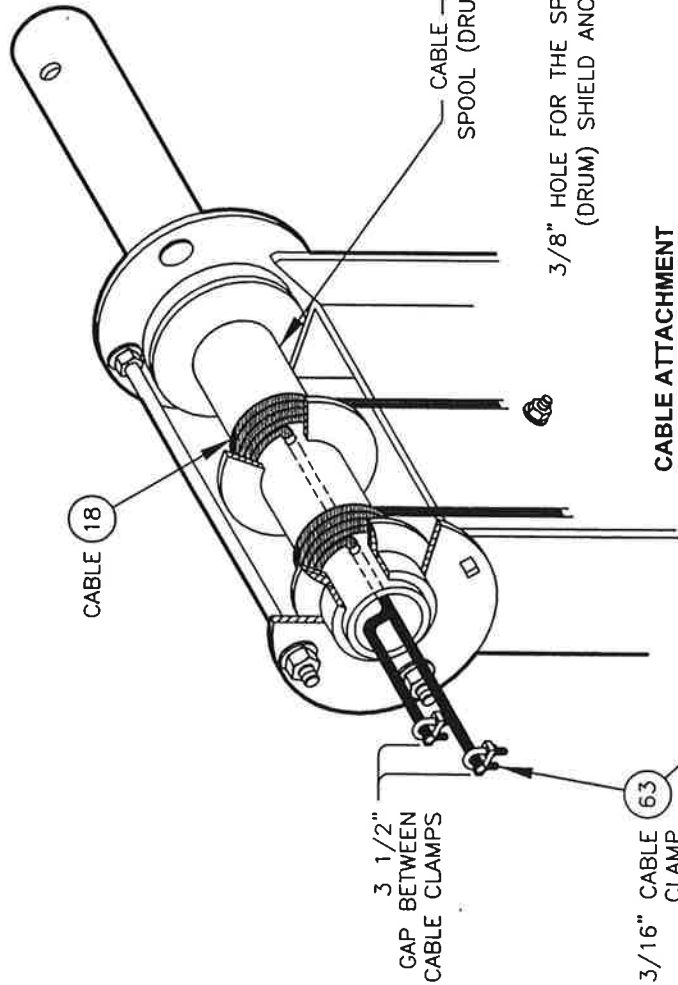
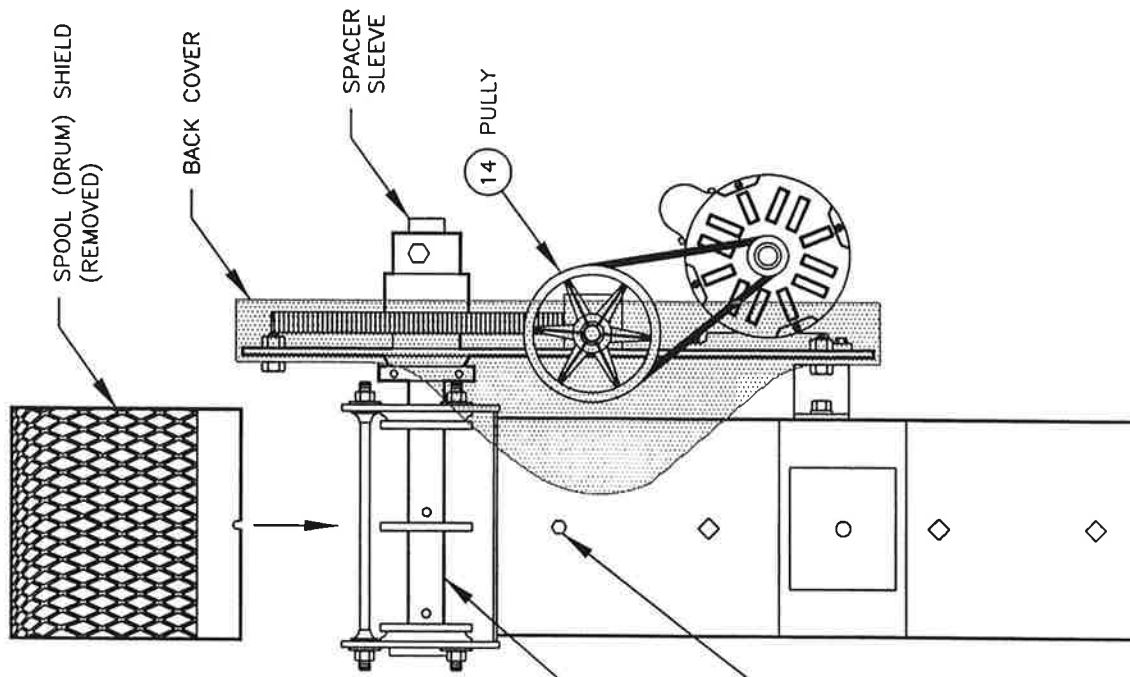

SECTION VIEW

CABLE CLAMP IS PULLED TIGHT INTO DRIVE PIPE

Project: Cable Connections Assembly
Detail and Cable Attachment

No.: 008
Revision Date:

Scale: None
Date: 12-19-00

Sheet: 1 of 1

GENERAL NOTES:

1. FOR LIST OF MATERIALS RELATED TO PART NUMBERS, SEE PARTS LIST.
2. SHEAVE PART NUMBER 6/7 IS A PLANE BORE SHEAVE ON MODEL 8,000 AND A STAINLESS STEEL BORE SHEAVE ON MODELS 10,000 AND 12,500.

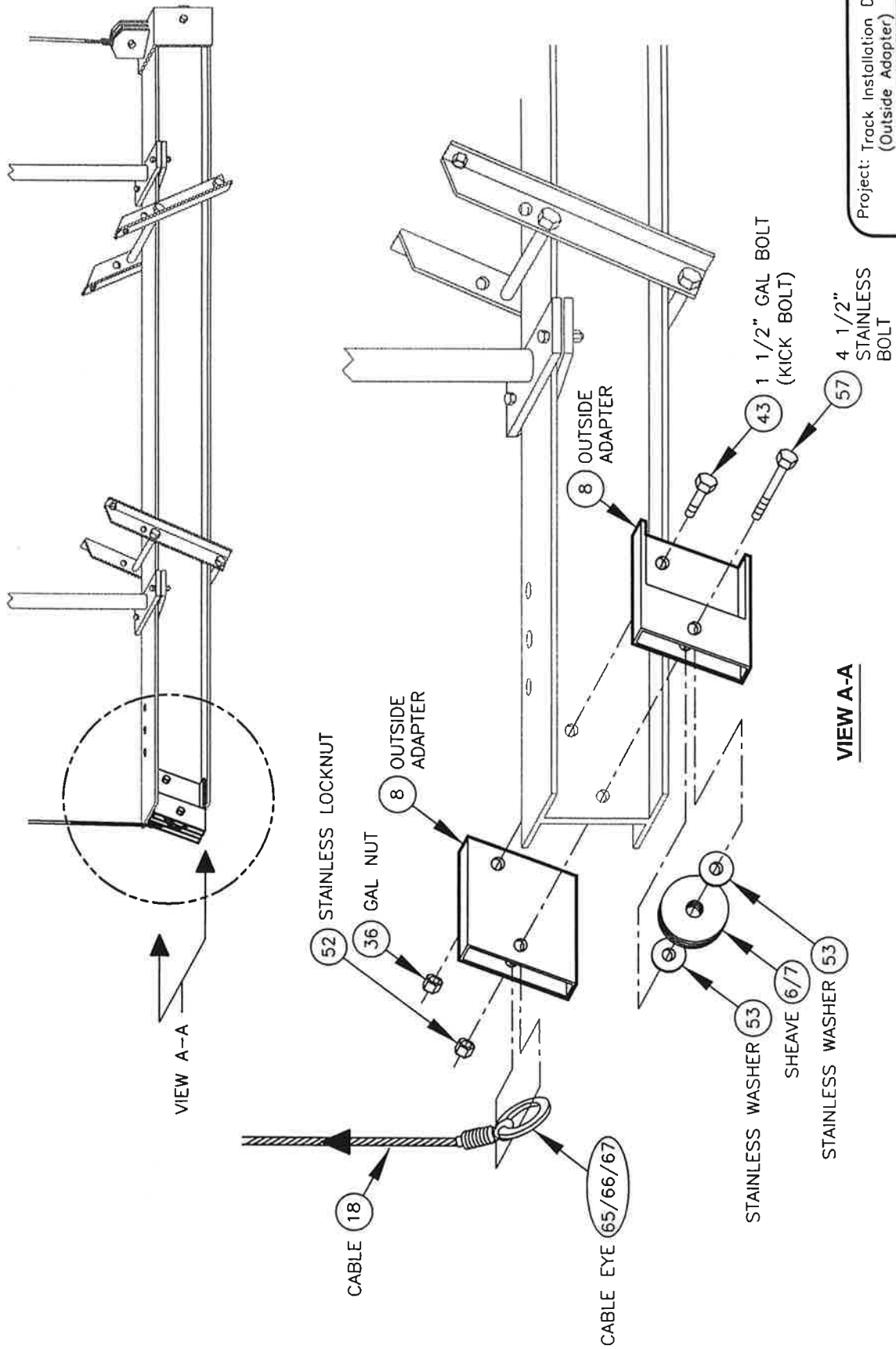

VIEW A-A

Project: Track Installation Detail (Outside Adapter)	
No.: 009A	Revision Date:
Scale: None	Date: 01-16-01
Sheet: 1 of 2	

GENERAL NOTES:

1. FOR LIST OF MATERIALS RELATED TO PART NUMBERS, SEE PARTS LIST.
2. SHEAVE PART NUMBER 6 IS ALWAYS A PLANE BORE SHEAVE, SHEAVE PART NUMBER 7 IS A STAINLESS STEEL BORE BUSHING SHEAVE ON MODELS 10,000 AND 12,500 ONLY.

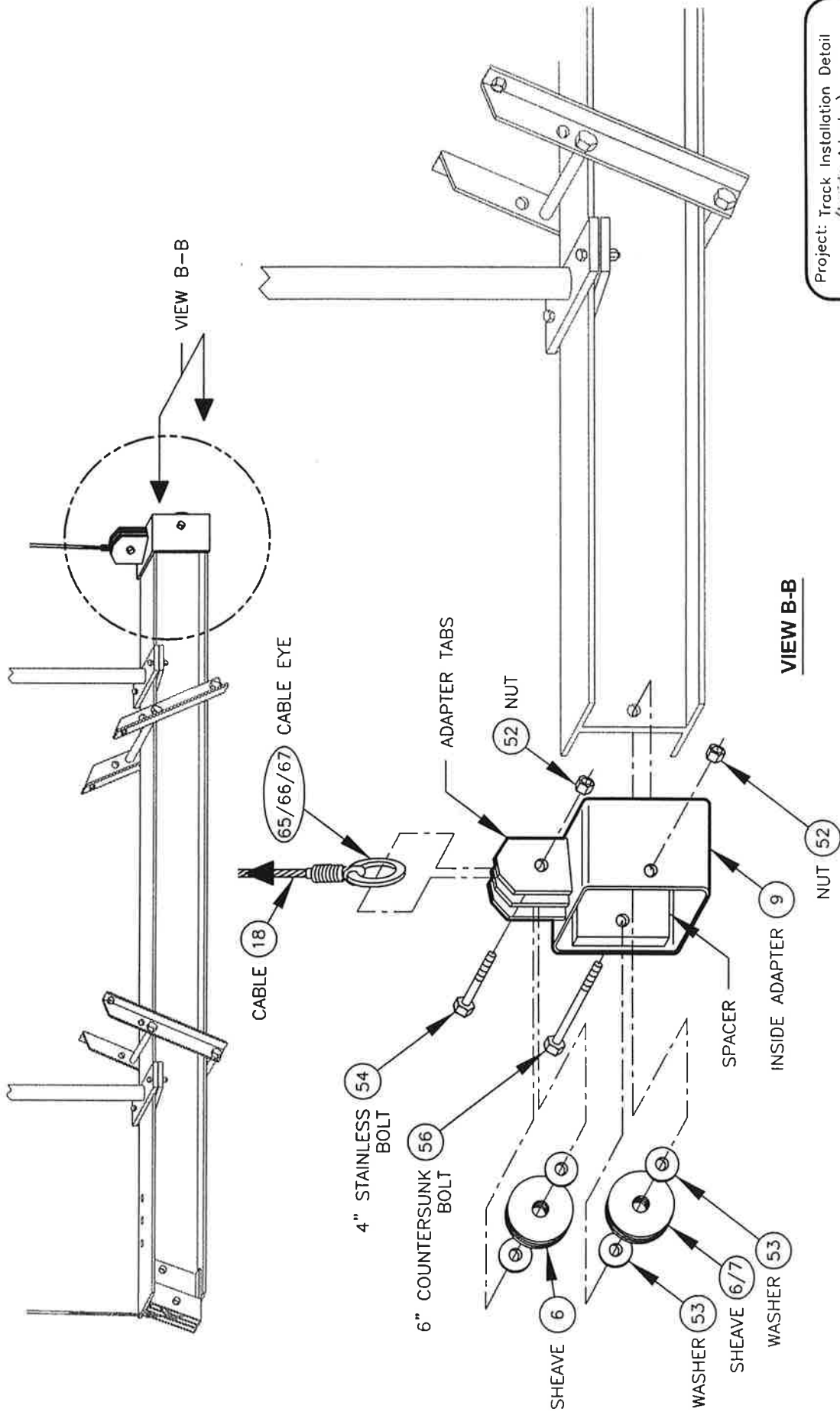

Project: Track Installation Detail (Inside Adapter)	
No.: 009B	Revision Date:
Scale: None	Date: 01-16-01
Sheet: 2 of 2	

GENERAL NOTES:

1. ONE PIECE OF 2 1/2" X 2 1/2" ANGLE IS SUPPLIED WITH THE THE "S MODEL" TO SERVE AS A SUPPORT FOR THE CATWALK. THE BRACE SHOULD BE ATTACHED TO BOTH THE BOW AND STERN LIFTING BEAMS.
2. FOR LIST OF MATERIALS RELATED TO PART NUMBERS, SEE PARTS LIST.

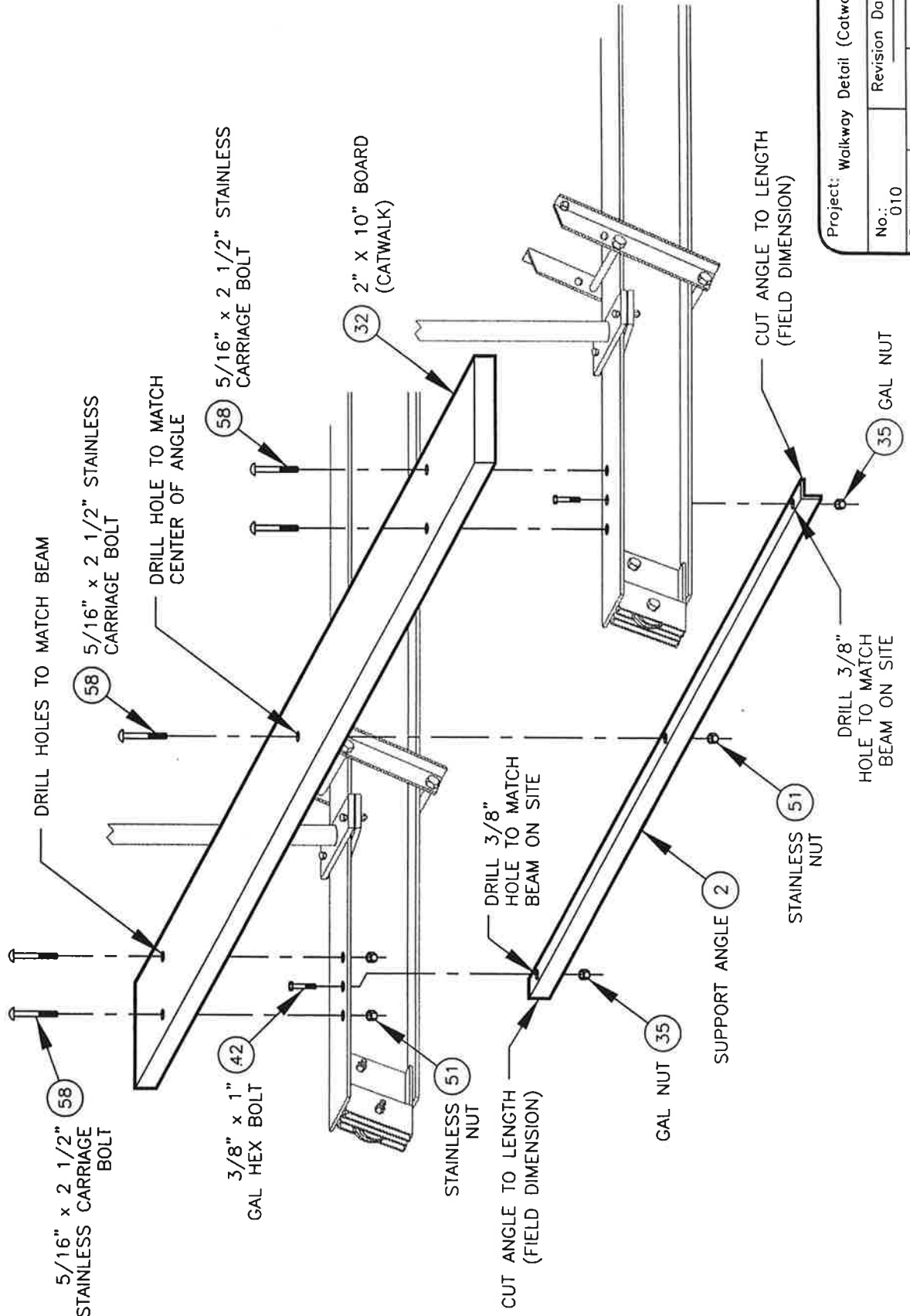

Project: Walkway Detail (Catwalk)	
No.: 010	Revision Date:
Scale: None	Date: 01-11-01
Sheet: 1 of 1	

GENERAL NOTES:

1. ENOUGH CABLE IS SUPPLIED WITH THE LIFT TO LOWER THE LIFT 9' BELOW SHEAVE BOLT S1. IF A GREATER AMOUNT OF DROP IS REQUIRED, CALL YOUR LIFT SUPPLIER TO ACQUIRE LONGER CABLES.
2. FOR LIST OF MATERIALS RELATED TO PART NUMBERS, SEE PARTS LIST.

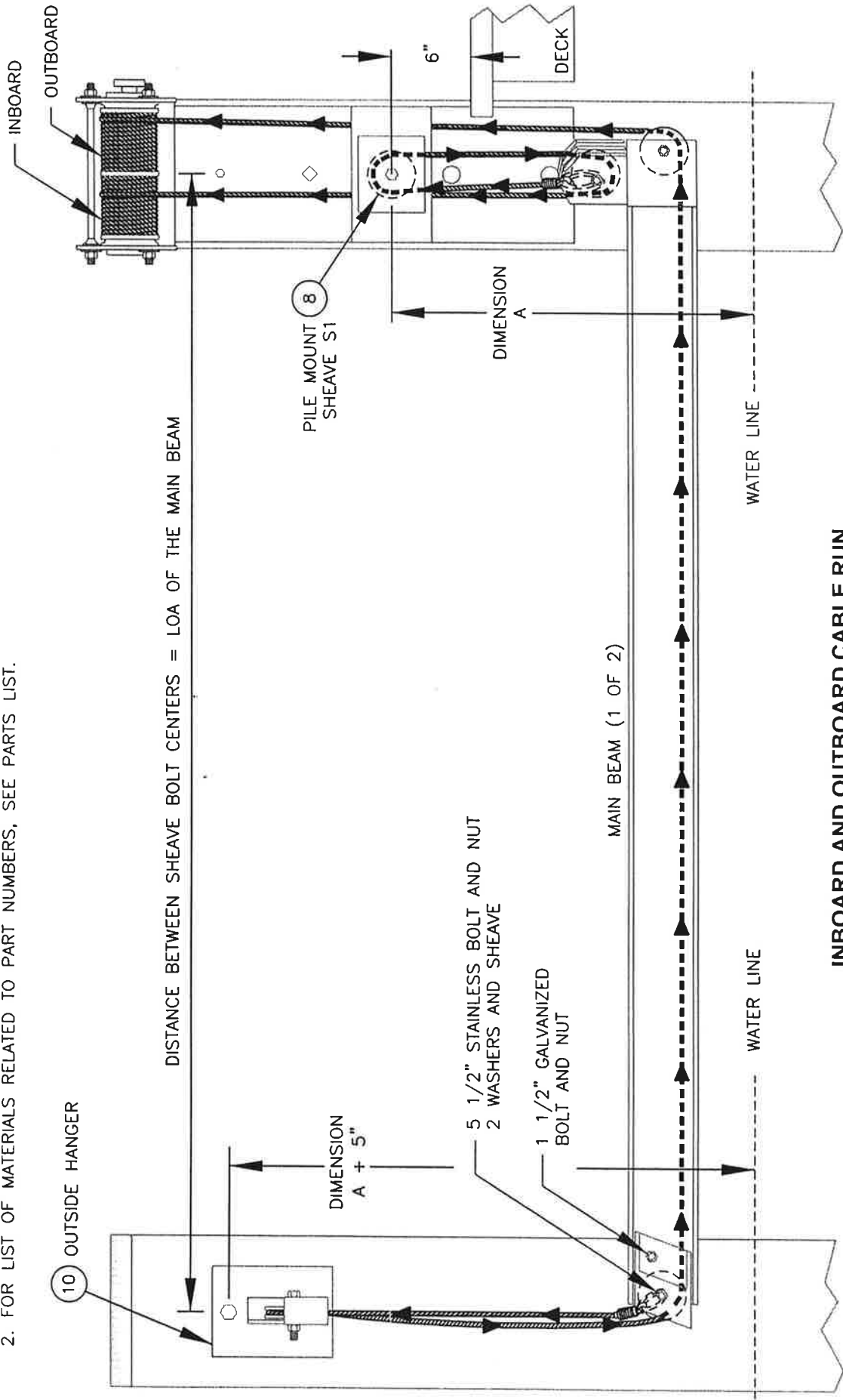

DISTANCE BETWEEN SHEAVE BOLT CENTERS = LOA OF THE MAIN BEAM

INBOARD AND OUTBOARD CABLE RUN

Project: "S" Model Cable Detail	
No.: 011A	Revision Date:
Scale: None	Date: 01-10-01
Sheet: 1	of 3

GENERAL NOTES:

1. ACTIVATE THE SWITCHES AND ROTATE BOTH DRUMS UNTIL THE HOLES IN THE DRUM FACE AWAY FROM THE PILING.

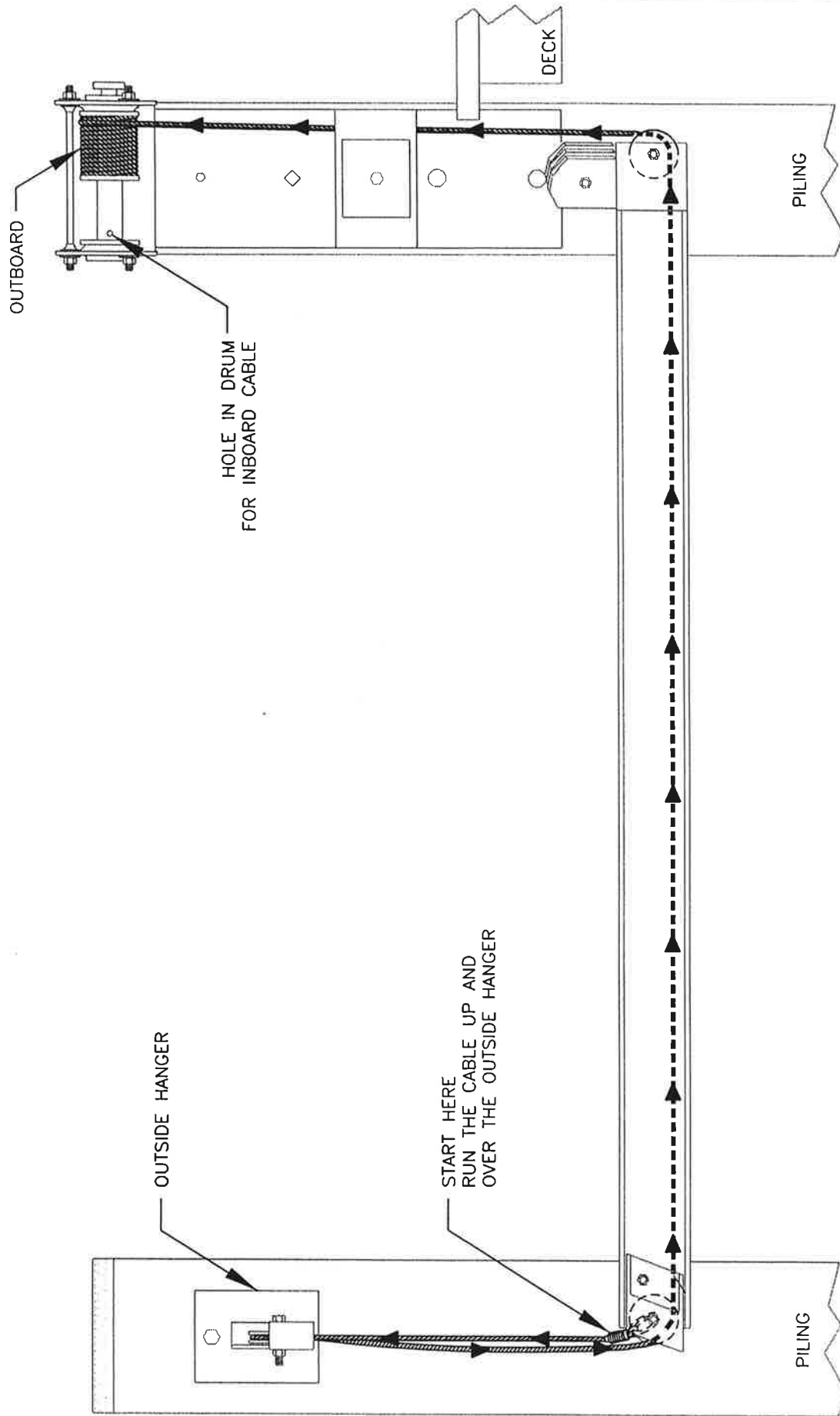

OUTBOARD CABLE RUN

Project: "S" Model Cable Detail	
No.: 011B	Revision Date:
Scale: None	Date: 01-10-01
Sheet: 2 of 3	

GENERAL NOTES:

1. MAKE SURE THE HOLES IN THE DRUM FACE AWAY FROM THE PILING.

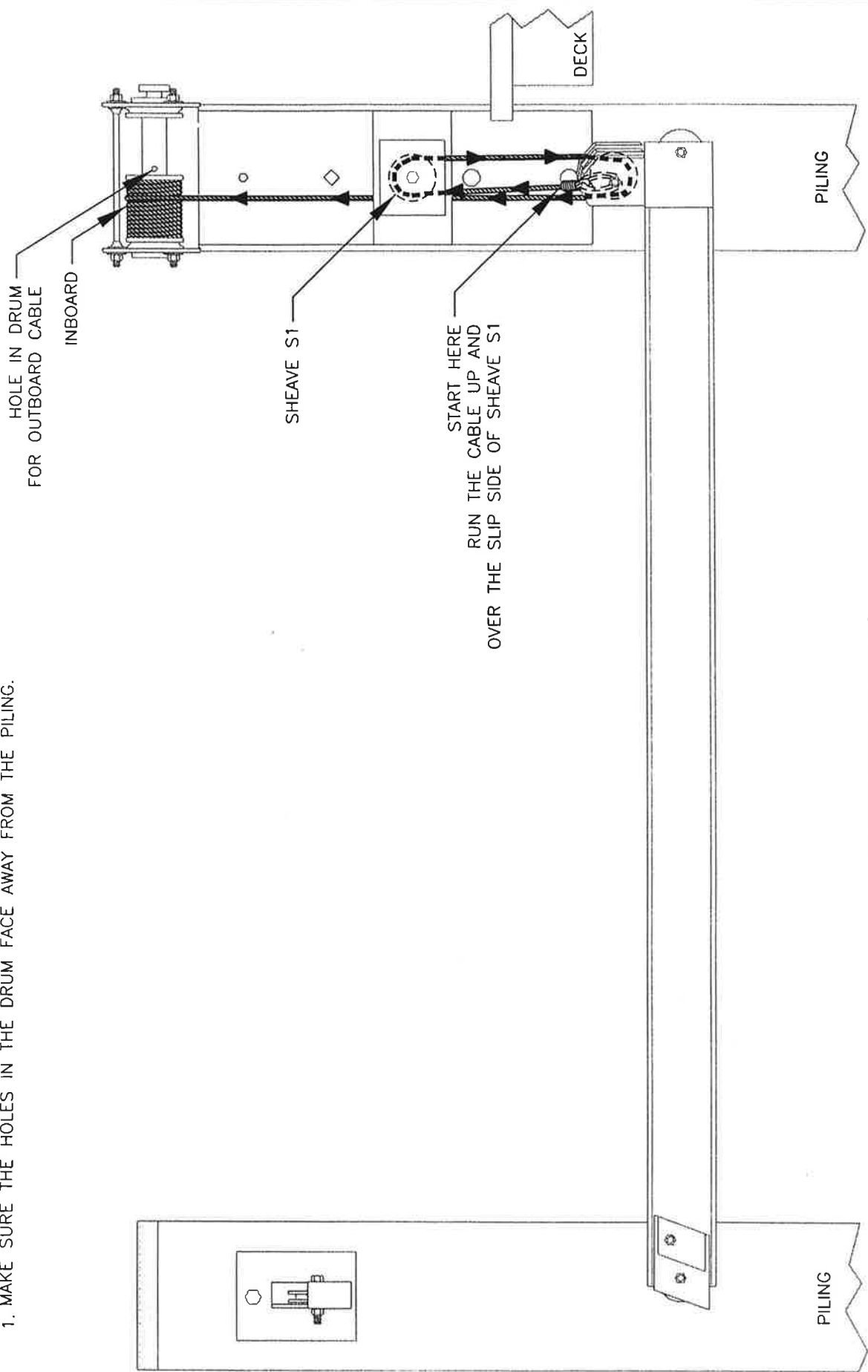

INBOARD CABLE RUN

Project: "S" Model Cable Detail	
No.: 011C	Revision Date:
Scale: None	Date: 01-10-01
	Sheet: 3 of 3

GENERAL NOTES:

1. TWO PADS MADE FROM TWO 6" x 24" CARPET PIECES ATTACHED TO TWO 2" x 4" x 22" WOOD PIECES (BOW AND STERN PADS), HELD DOWN WITH TWO PER PAD-5/16" x 2 1/2" STAINLESS CARRIAGE BOLTS (OPTIONAL).
2. FOR LIST OF MATERIALS RELATED TO PART NUMBERS, SEE PARTS LIST.

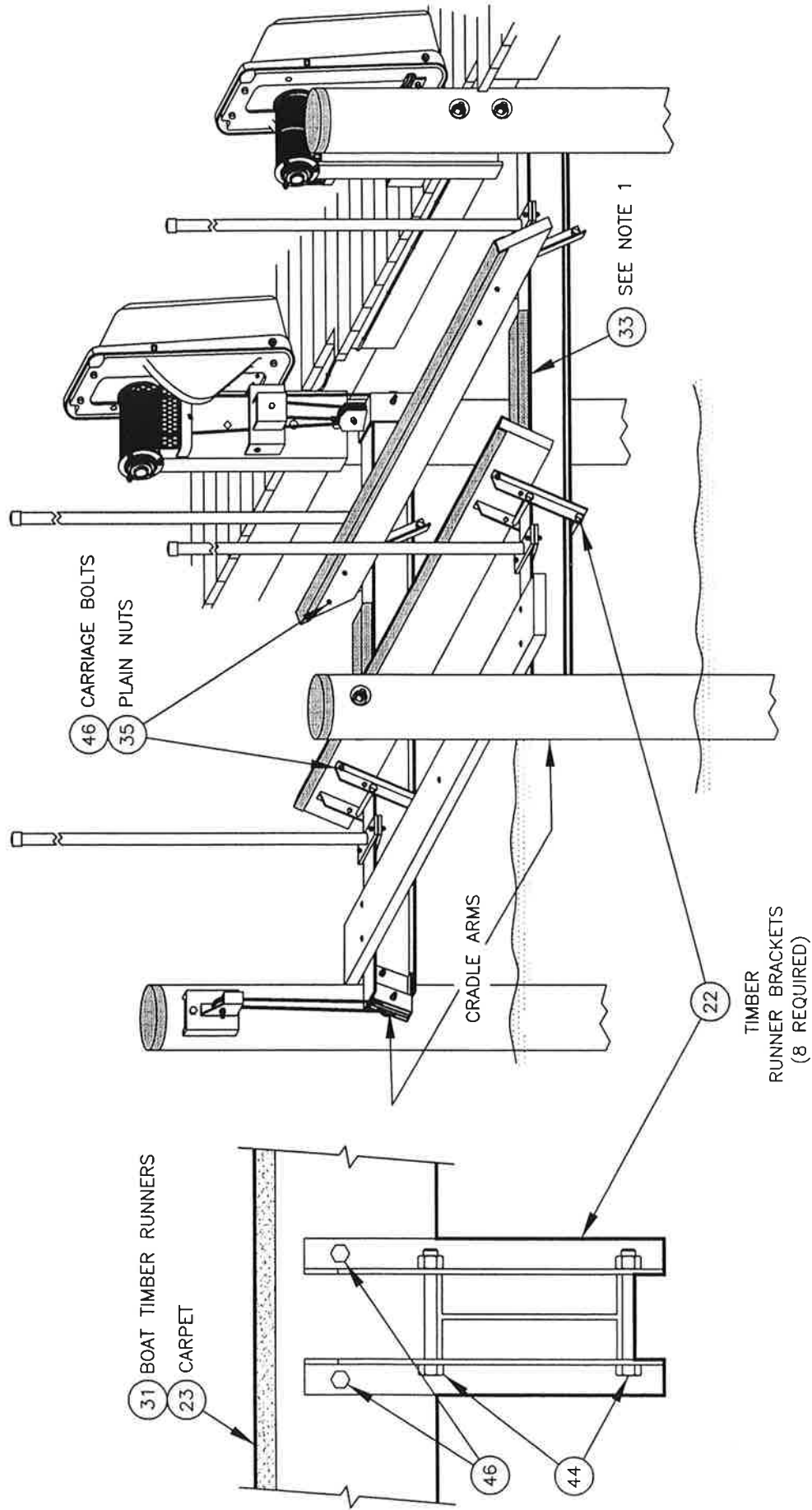

Project: Chock Rails	
Assembly Detail	
No.: 012	Revision Date:
Scale: None	Date: 12-19-00
	Sheet: 1 of 1

GENERAL NOTES:

1. DISTANCE BETWEEN CENTER OF GUIDE POLES DETERMINED BY WIDTH OF BOAT.

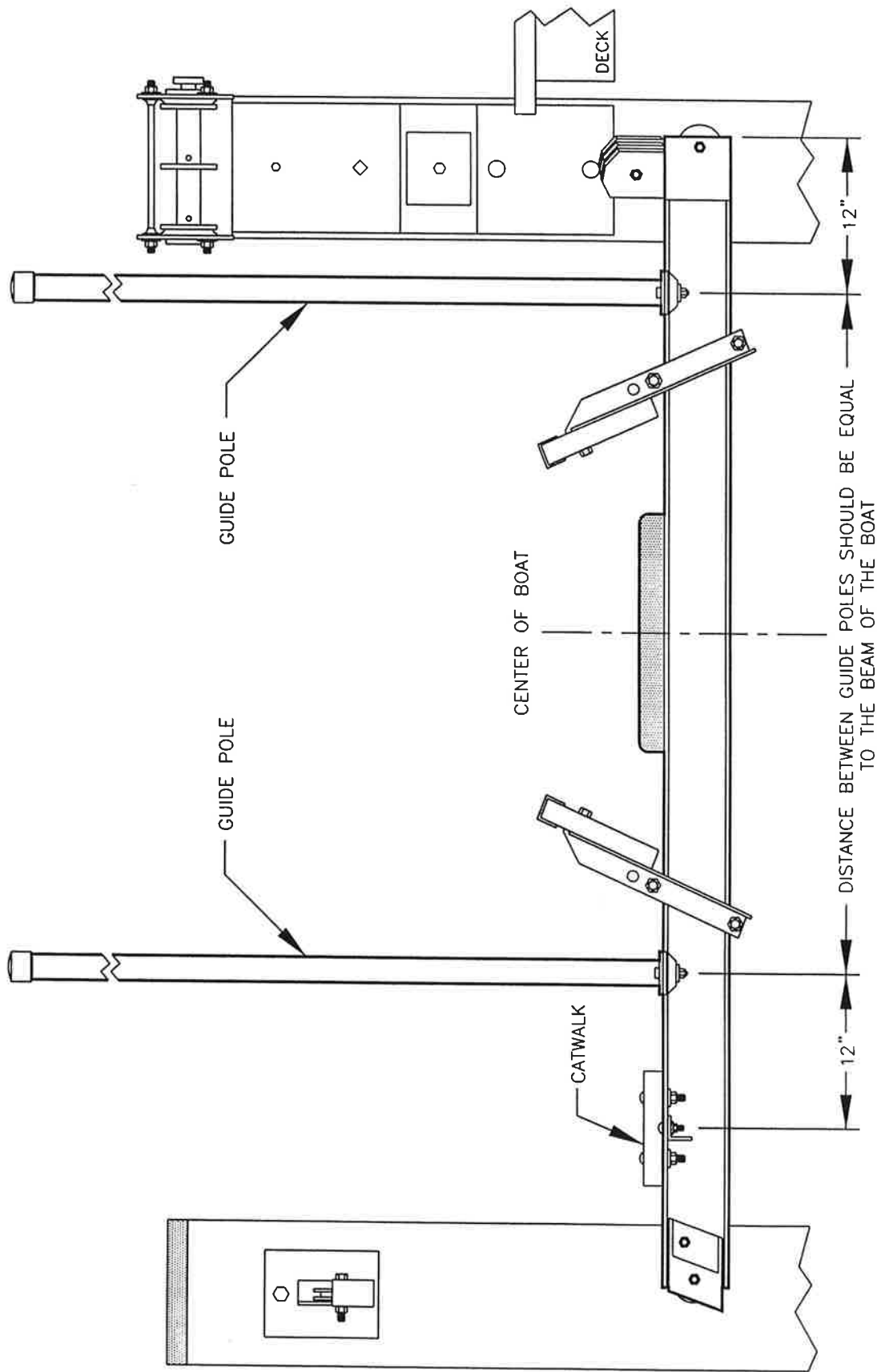

Project: Guide Pole And Catwalk Placement	
No: 013	Revision Date:
Scale: None	Date: 02-02-01
	Sheet: 1 of 1

GENERAL NOTES:

1. FOR OPTIMUM PERFORMANCE, EQUAL WEIGHT DISTRIBUTION IS REQUIRED OVER BOTH CRADLE ARMS.
2. TO OBTAIN EQUAL WEIGHT DISTRIBUTION:
 - A. USE BALANCE POINT OF BOAT.
 - B. DO NOT USE CENTER OF BOAT LENGTH.
3. POSITION THE BOAT IN THE LIFT AS CLOSE TO THE TRACK AS POSSIBLE.

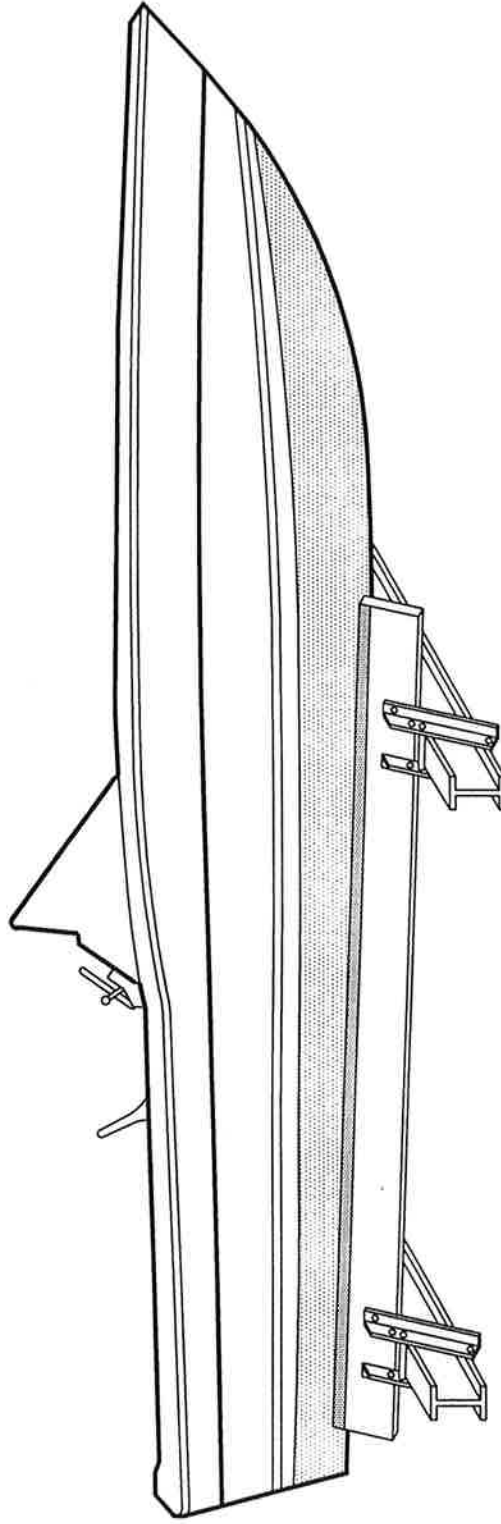

Project: Instructions For			
Weight Distribution			
No.:	014	Revision	Date:
Scale:	None	Date:	06-12-00
Sheet:			1 of 1

GENERAL NOTES:

1. THE LIFT CAN ACCOMMODATE DIFFERENT TYPES OF WATER CRAFT BY ALTERING THE POSITION OF THE TIMBERS.

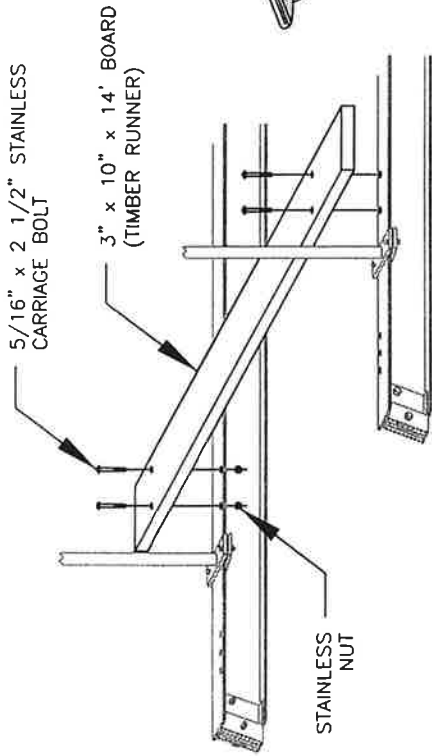

VIEW A-A

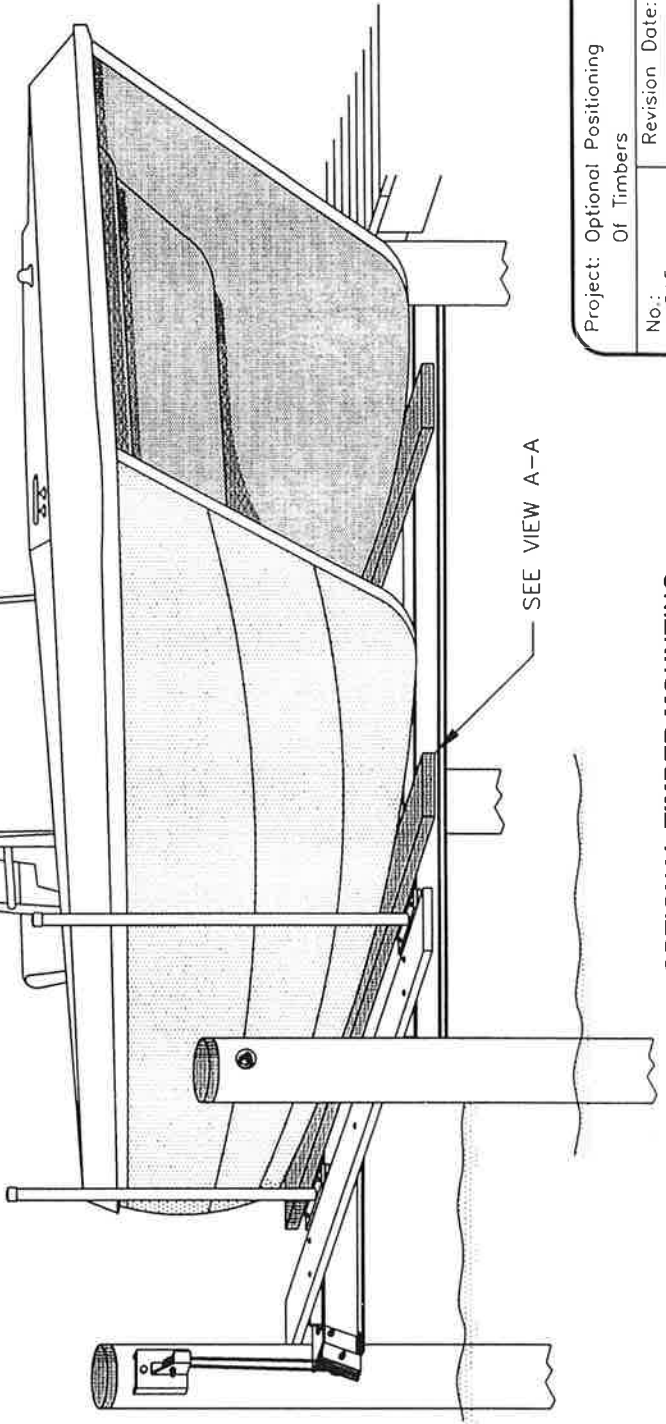

OPTIONAL TIMBER MOUNTING

Project: Optional Positioning Of Timbers	
No.: 015	Revision Date:
Scale: None	Date: 01-22-01
	Sheet: 1 of 1