



ASSEMBLY GUIDE

Adirondack Chair

KING1 - CHL1 - CHS1 [10.11.12]



TOOLS

- 7/16" Wrench
(Socket wrench recommended)
- Screwdriver/Square bit #1
(Power screwdriver/Square bit #1 recommended)
- Hammer & Flashlight.

COMPONENTS

Part#	Description	Qty
(A)	Arm Rests with front legs	2
(B)	Seat Base	1
(C)	Front leg cross-support	1
(D)	Chair Back support	1
(E)	Chair Back	1
(F)	Lag bolts	4
(G)	Wood screws	4
(H)	Carriage bolts	2
(I)	Metal washers	6
(J)	Lock nuts	2
(K)	Plastic washers	8

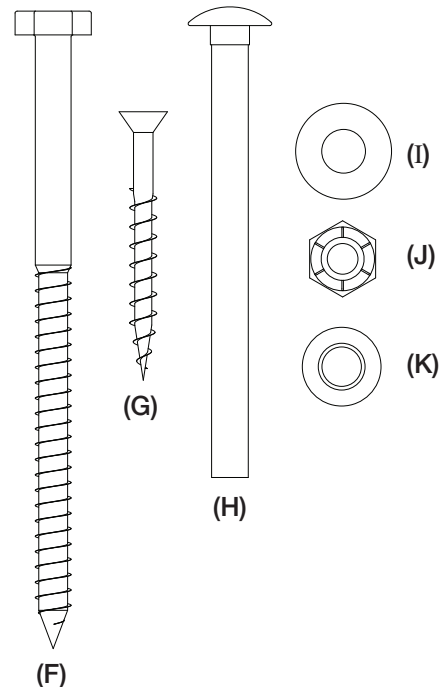
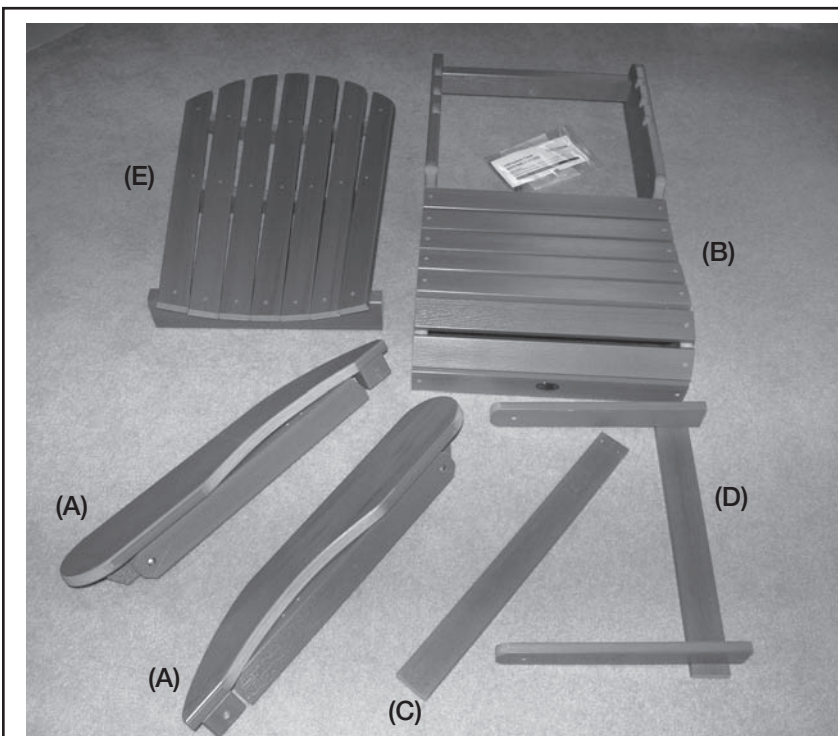

Before you start

This assembly can be done by one person alone, however it is much easier when two people work as a team. Also, do not over-tighten bolts, but ensure that a firm and secure connection is made in every instance to avoid excess movement in joints.

STEP 1

Seat Base

Take two Plastic Washers (K) and insert one into the pre-drilled holes on each inside edge of the Seat Base (B) as shown in image #1.

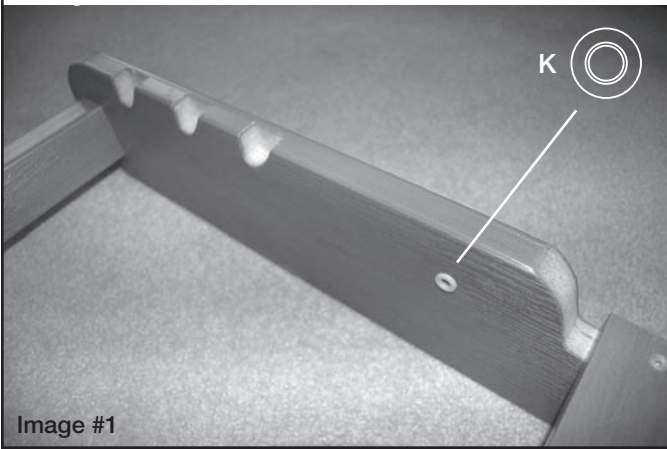

STEP 2

Connect Seat Back to Seat Base

This is where a buddy comes in handy. Position and hold the Seat Back (E) and Seat Base (B) together, and attach using a Lag Bolt (F) and Metal Washer (I) as shown in image #2. Repeat on other side.

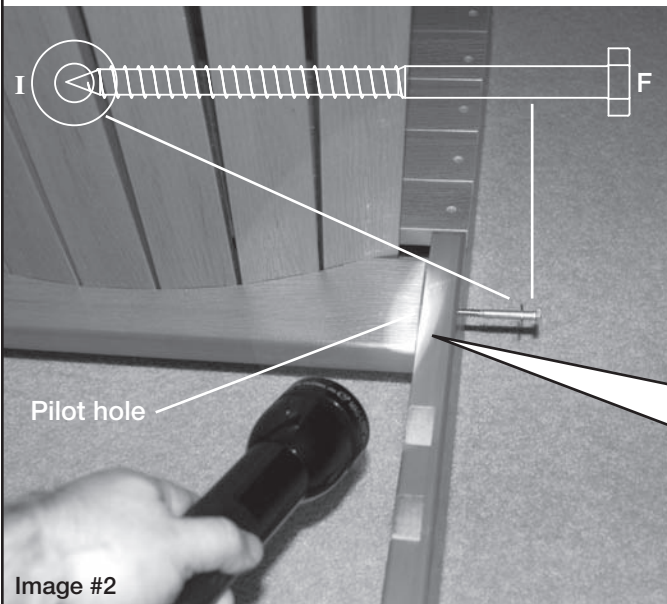

STEP 3

Attach Chair Back Support

Insert four Plastic Washers (K) into their pre-drilled holes in the Chair Back Support (D) as shown in image #3.

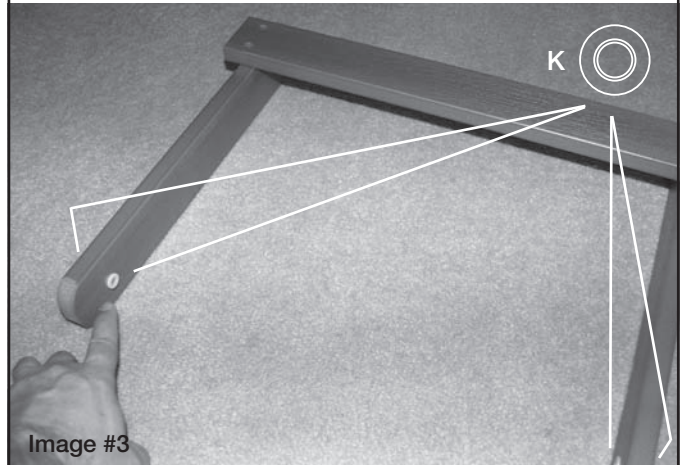

We will now connect the Chair Back Support (D) to the Arm Rest (A) and Seat Back (E) as shown in image #4. (Step #3 directions continued on next page).

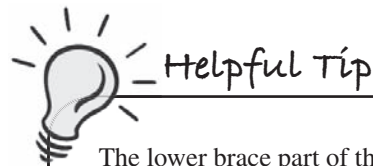
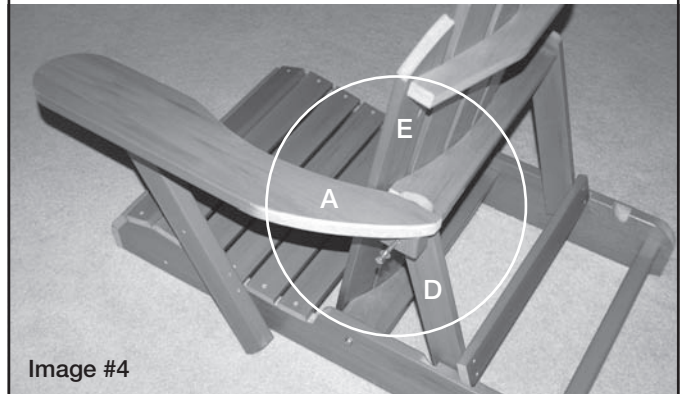

Helpful Tip

The lower brace part of the Seat Back that the Lag Bolt goes through has a **pilot hole** to show where the Lag Bolt should enter. Use a flashlight as shown in image #2 to see down between this brace and the Seat Base to ensure that the Bolt enters this spot. **(It is important that the Lag Bolt runs through the center of this brace).**

STEP 3

Attach Chair Back Support (cont.)

With your buddies help, line up the holes in the Arm Rest (A), Chair Back Support (D), and Chair Back (E), and push Lag Bolt (F) and Metal Washer (I) through as shown in image #5. Use the **pilot hole** to ensure that the Lag Bolt passes through the center of the cross brace. Tighten the Lag Bolt and repeat on other side.

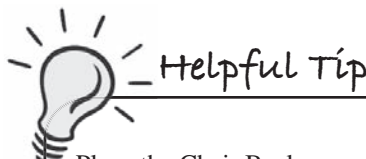
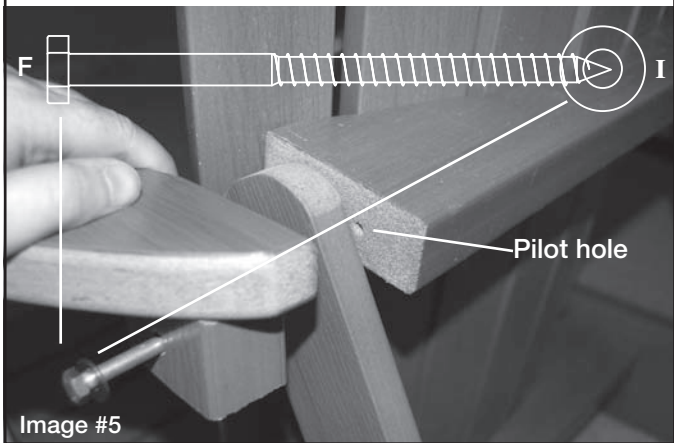

Helpful Tip

Place the Chair Back Support (D) into the middle of the 3 reclining notches to help keep it in place as you connect the 3 components with the Lag Bolt.

Be sure the chair back support is positioned with the brace facing outward.

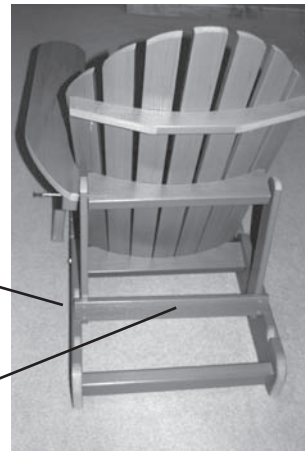

STEP 4

Attach Front Legs to Seat Base

Insert Plastic Washer (K) into the pre-drilled hole on Seat Base (B), as shown in image #6. Lift the front of the seat and align the hole with the pre-drilled hole in the front leg and slide Carriage Bolt (H) through to attach, as shown in image #7. **Note:** Holes are pre-drilled for the Carriage Bolt to pass through, but use a hammer to firmly tap the bolt end several times so that the square neck sinks into the *highwood*[®] material. Repeat on other side.

Attach Metal Washer (I) and Lock Nut (J) to the carriage bolt from the inside of seat base and tighten so that it further pulls the bolt neck into the material... leaving just the dome flush with the surface. Repeat on other side.

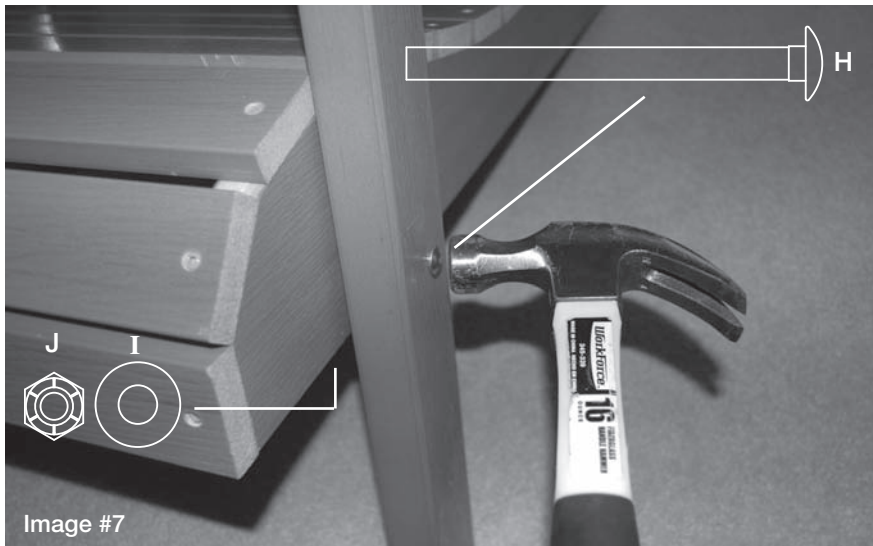
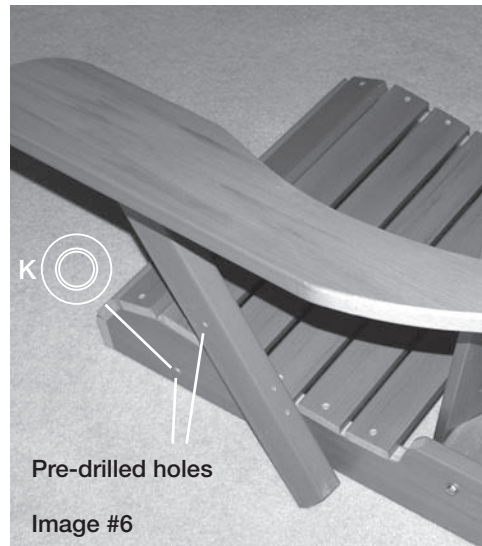
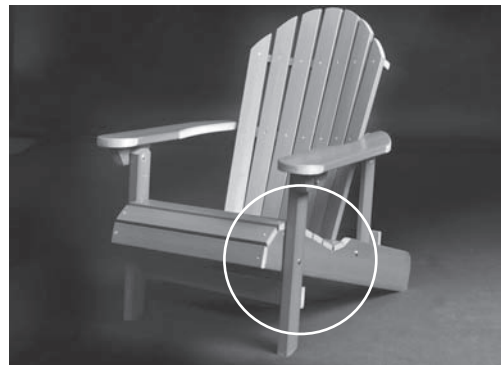

STEP 5

Front Leg Support

Carefully turn the chair onto its side (on carpet or a soft surface). Note that **pilot holes** on the inside of chair legs show exactly where leg cross support should be attached as shown in image #7. Using the four Wood Screws (G), screw the Front Leg Cross Support (C) to the rear of the front legs (A) into pilot holes. See image #8.

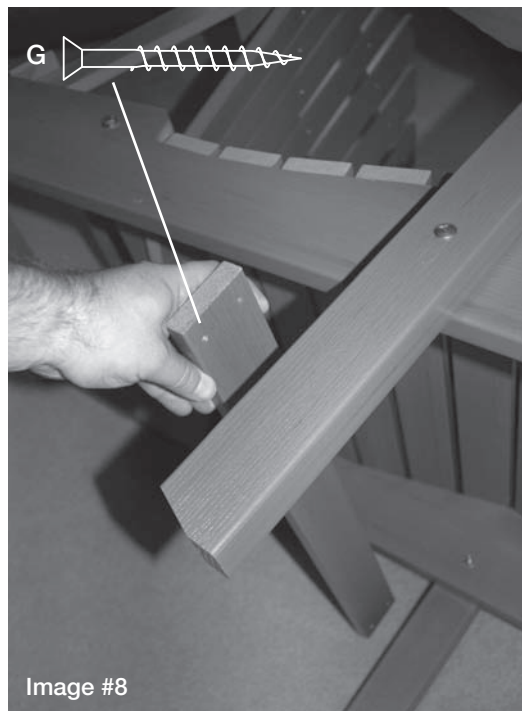
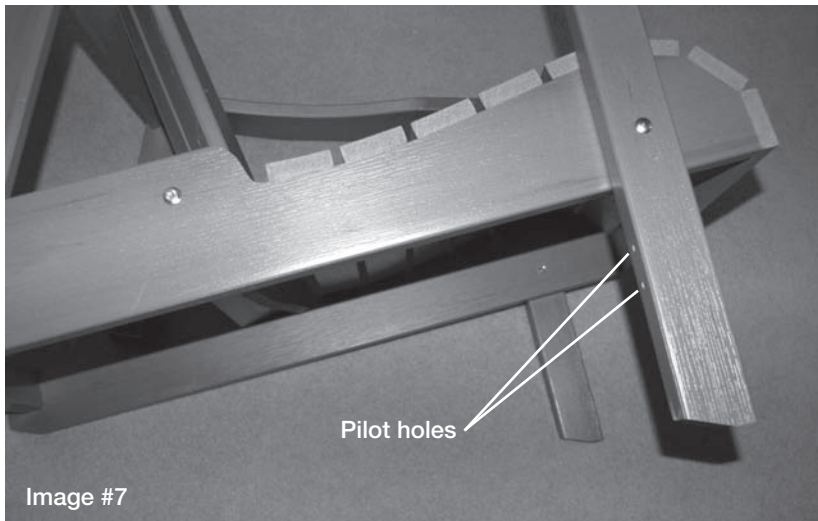

ENJOY YOUR HIGHWOOD CHAIR!

IMPORTANT NOTES

NEVER adjust the level of recline while you are sitting in the chair, or while anyone else is in the chair. Always adjust with an empty chair and ensure that the back-support is completely secure in the recline-slots on each side of the chair.

To fold the chair, lift the back-support and push down on the seat back gently... the chair will collapse down to floor level.



Visit our Website and Facebook page to see more *highwood*[®] products!

www.highwood-usa.com • www.facebook.com/highwoodUSA