

WISHBONE PLUS MONITOR ARM

Code: WSH/011

Wishbone Plus can support monitor weights up to 24kg, meaning it can comfortably hold monitors up to 37". The arm offers similar reach and articulation to the standard Wishbone and includes significant functional enhancements such as a built-in fine height adjustment feature and easy portrait-to-landscape monitor orientation.

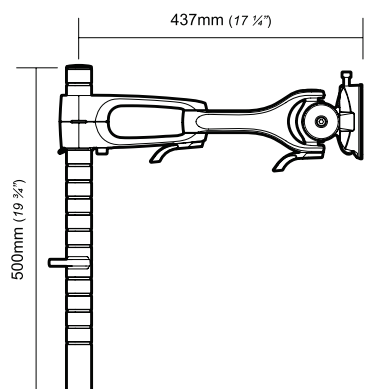

TECHNICAL SPECIFICATIONS

BASIC SPECIFICATIONS

Screen Size:	Up to 37"
Screen Weight:	Up to 24kgs
Colour	Silver

MORE SPECIFICATIONS

Arm Length:	470mm
Post:	500mm (recommended)
Mounting:	VESA MIS-D 100x100mm mounting pattern

MONITOR FLEXIBILITY

Vertical Adjustment:	N/A
Tilt:	100° upward -180° downward
Pan:	180°
Rotation:	360° (portrait to landscape)



PRODUCT CODES

DESCRIPTION	CODE
Wishbone Plus with clamp - Silver	WSH/011/C/S
Wishbone Plus with through desk - Silver	WSH/011/TD/S
Wishbone Plus with cast grommet - Silver	WSH/011/CG/S