

WISHBONE MONITOR ARM

Code: WSH/001

Wishbone is a design classic, it has won design and product innovation awards the world over. It is a true system arm available in three reach lengths which make it the ideal choice for multi-screen applications such as trading floors and control rooms. Wishbone can be installed at different heights to suit different environments and users.

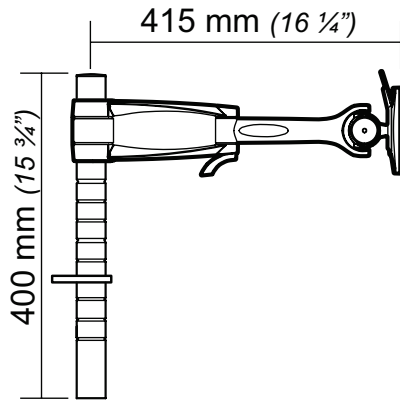

TECHNICAL SPECIFICATIONS

BASIC SPECIFICATIONS

Screen Size:	Up to 30"
Screen Weight:	Up to 12kgs
Colour	Silver

MORE SPECIFICATIONS

Arm Length:	425mm
Post:	400mm (recommended)
Mounting:	VESA MIS-D 75x75mm & 100x100mm mounting patterns

MONITOR FLEXIBILITY

Vertical Adjustment:	N/A
Tilt:	100° upward -160° downward
Pan:	180°
Rotation:	90° (portrait to landscape)



PRODUCT CODES

DESCRIPTION

Wishbone with clamp - Silver
Wishbone with through desk - Silver
Wishbone with cast grommet - Silver

CODE

WSH/001/C/S
WSH/001/TD/S
WSH/001/CG/S