





LINUS BIKES

SIZE CHART

ROADSTER	SIZE	HEIGHT	INSEAM
	<i>Small</i>	cm: 152cm/163cm ft/in: 5'0" - 5'4"	cm: 72cm in: 28"
	<i>Medium</i>	cm: 163cm - 175cm ft/in: 5'4" - 5'9"	cm: 76cm in: 30"
	<i>Large</i>	cm: 175cm - 188cm ft/in: 5'9" - 6'2"	cm: 83cm in: 33"

GASTON	SIZE	HEIGHT	INSEAM
	<i>Small</i>	cm: 152cm/163cm ft/in: 5'0" - 5'4"	cm: 72cm in: 29"
	<i>Medium</i>	cm: 163cm - 175cm ft/in: 5'4" - 5'9"	cm: 76cm in: 30"
	<i>Large</i>	cm: 175cm - 188cm ft/in: 5'9" - 6'2"	cm: 83cm in: 33"

MIXTE	SIZE	HEIGHT
	<i>Small</i>	cm: 147cm - 160cm ft/in: 4'10" - 5'3"
	<i>Medium</i>	cm: 157cm - 178cm ft/in: 5'2" - 5'10"
	<i>Large</i>	cm: 175cm - 188cm ft/in: 5'9" - 6'2"

DUTCHI	SIZE	HEIGHT
	<i>Small</i>	cm: 147cm - 160cm ft/in: 4'10" - 5'3"
	<i>Medium</i>	cm: 157cm - 178cm ft/in: 5'2" - 5'10"



LINUS BIKES

SIZE CHART

Whoah, what the heck is an inseam?

An inseam is the measurement of the inside of your leg. This is used to see if you can comfortably stand over your Linus bike.

How does one measure an inseam?

It's really easy- it only takes less than a minute! You will need:

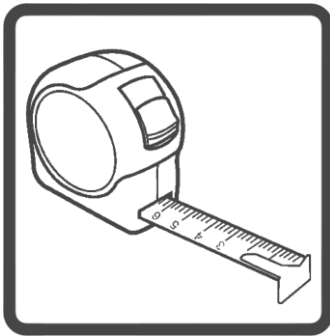

A tape measure



A hardcover book



A friend

Follow these 3 simple steps:

1. Get a hardcover book with a solid spine and place it in between your legs with the spine facing your crotch. (try and get the spine as snug as possible to your crotch)
2. Stand up as straight as you can with your back against a wall.
3. Get a tape measure and get your friend to measure from the tip of the spine of the book to where the inside of your foot meets the ground.

PLEASE NOTE: Whilst measuring your inseam, try and wear the shoes you intend to use when riding for a more accurate measurement!!

Ta-da! You have just measured your inseam! Now choose your Linus and get riding!

