

Merry
Christ-Mess!

...Beyond Time!

*Only God
Can Turn
A Mess
Into A Message!*



Only God Can Turn
A Mess Into A Message!

Merry
Christ-Mess!
... Beyond Time!

Merry Christ-Mess!

...Beyond Time!

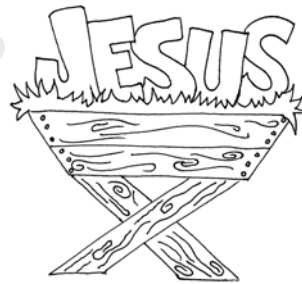

*Only God Can Turn
A Mess Into A Message!*



An Impractical Holiday Cleaning Guide

This year Christmas is getting messy! What happens when a long forgotten messy room suddenly becomes the center of attention? Uncover a mysterious, messy place that demands a thorough cleaning. Organizing Room 211 is challenging but may yield a unique treasure or two...*Beyond Time!*

These pages contain plans and script for a unique Christmas program designed to delight young and old.

Open it carefully!

You never know what will pop out.

For those who think the story about the day Jesus was born is old and dusty, think again. It is as fresh as morning dew and as relevant as today's newspaper.

Merry Christ-Mess...Beyond Time is a thought provoking Christmas program. Present a delightful event featuring an imaginary journey through a messy storage room to the stable in Bethlehem. Funny, inspirational and memorable, the program is divided into easy to prepare segments for small groups of all ages.

Gather your church family!

A trip ...Beyond Time...

can be as close as your nearest messy room!

*Jesus said, "I am the Door:
by Me if any man enter in, he shall be saved."*

John 10:9

Index



An Impractical Holiday Cleaning Guide.....	1-3
Merry Christ-Mess...Beyond Time.....	4
The Christ-Mess Director.....	5-6
Adaptations.....	7
Christ-Mess Music Tips.....	8
Stage And Props.....	9
Costumes.....	10-11
Publicity.....	12
Christ-Mess Teachers.....	13-15
Just A Word About Memorization.....	16
Main Characters.....	17-18
Staging Suggestions.....	19
Christ-Mess At A Glance.....	20
The Prelude and The Procession.....	21
ACT 1: Room 211.....	22-24
Preschool: Church Mice.....	25-26
Elizabeth and Mary.....	27-28
Kindergarten: Holiday Inn.....	29-31
Grade 1: Shepherds In Sneakers.....	32-34
ACT 2: Lights, Camera, Action.....	35-37
Grades 2-3: Earthbound Angels.....	38-39
Grades 4-5: Snap, Crackle and Pop.....	40-42
ACT 3: It All Makes Sense.....	43-44
Grade 6: Meeting Jesus.....	45-46
Teens and Adults: Beyond Time.....	47-51
Conclusion: Only God Can Turn A Mess Into A Message.....	52-54
Open The Door Party.....	55-56

Merry Christ-Mess! ...Beyond Time!

Only God Can Turn A Mess Into A Message!

Merry Christ-Mess...Beyond Time is an All church/school Christmas program featuring folks of all ages. Love to laugh? Need a reminder of what makes Christmas special? This is the Christmas program for you! Easy to prepare and ...**NO MEMORIZATION!**

Merry Christ-Mess...Beyond Time is rehearsed in small groups with their teacher/leader or group of friends. Gather the whole group for a final rehearsal and the program is ready to take to the stage.

Merry Christ-Mess...Beyond Time has a childlike sense of 'pretend'. The reality of Jesus' birth shines beyond time through the mess. Tell the beloved Bethlehem story as surprised Holy Land people come from somewhere beyond the messy room with amazing stories. It is fun to play 'What if' and engage the audience in Jesus' story in a new way.

Merry Christ-Mess...Beyond Time audience sings Christmas Carols. Special music performed by local talent is sprinkled through the event as Jesus' story unfolds on your stage. **We offer an optional 3 song CD/printed music package to make a great addition to the program.**

Merry Christ-Mess...Beyond Time concludes with an *Open The Door Party!* Decorate, serve delicious desserts or party foods and play Christmas music. It becomes a lasting memory for everyone!

COPYRIGHT

Make as many printed copies as needed for local church/school use. Give interested folks our order form, mailing address, web site address: www.cemlife.com and toll free telephone (1.888.236.5433). Your cooperation allows CLOSE ENCOUNTERS MINISTRIES to continue producing exciting, inspiring, positive Christian programs at low cost to churches across the nation and the world. Copyright-All Rights Reserved protected.

The Christ-Mess Director

Organize this humorous, 'divine' Christmas celebration. No age limits!
Assign small group leaders who take charge of individual segments.

Make program copies and assign segments to Sunday School classes, church committees, small groups of friends and willing individuals who agree to become part of Merry Christ-Mess...Beyond Time.

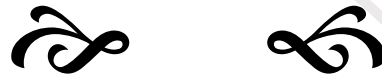

Follow Directions

Leaders organize their small group complete with props and costumes. Be prepared to help but for the most part individual leaders should handle their material. The Bethlehem story of Jesus is powerful and changes lives every time it is told.

Prepare Your Heart

For some church members, holiday programs comprise most, if not all, of their Christmas celebration. Do it for the Lord! Do it for those folks!

One Step At A Time

It is possible that you are thinking, *"Why me? I cannot do this!"* Put those feelings aside and dive into the appealing presentation of Christmas as experienced by two friends given the task of cleaning out a musty, old storage room. The audience and participants experience the adventure of a lifetime.

Delegate!

Leaders become involved by preparing their small group. Trust the staff to carry out their tasks. Check in with them often.

Be Positive!

It is worth extra effort in the midst of personal preparations, parties and travel to make Christmas events sparkle.

Statements like, "We can't do it", "We never did it this way" or "No one wants to do it", are inappropriate. If the Christmas Director's attitude is right, even the grouchiest saint responds cheerfully!

Pray!

Take details before the Lord and then-RELAX! Carry out the tasks at hand. God is in control!

Plan!

Print a working copy (**Do not write on this master copy!**) Mark areas requiring special attention. Adapt as needed. Eliminate what cannot be used, divide parts and combine parts when necessary. Give teachers and participants copies of their segment in a colorful folder.

Prepare!

Hopefully you have ordered *Merry Christ-Mess...Beyond Time* with more than a month lead time. Assign responsibility for small group practice to each teacher/leader.

No Memorization!

Some groups enjoy memorization and others avoid it. Except for the youngest non readers, it is possible to read all parts. Memorization requires lead time and intensive rehearsal.

This is an ALL CHURCH/SCHOOL Production!
Involve adults as readers, musicians and leaders.
Adapt the program using available number of participants.

Adaptations

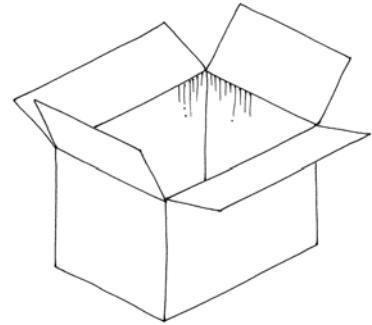

Merry Christ-Mess...Beyond Time lasts about forty five minutes depending upon music and personal choice additions or eliminations made to the original program. The *'Open The Door'* Party is not included in this time frame. Adapt the program to fit your favorite Christmas traditions. **It can be completed in less time.**

Small Church

Remove segments requiring more people than available. Combine speaking parts. Don't worry about correct ages for the segments. They are meant to be performed by any age as needed. Feature your favorite segments.

OR, use the same few people to present more than one segment. Teens and adults are crucial to the small presentation. Some people participate several times.

Medium Church

Adaptation takes the form of personal preference. Choose segments you like best. The goal is to tell the Christmas story so don't leave out anything important!

Large Church

Involve as many people as possible. Organize snack makers, servers, prop masters, sound/lighting staff and talented volunteers who make the program visually exciting.

'Open The Door' Party

Ask an adult class or group of friends to complete party plans. They decorate, plan and prepare food and clean up. This is a fun option. If time does not allow for a social gathering, plan a great program and eliminate the party!

Christ-Mess Music Tips

Coordinate music with music director, organist/pianist. Choose favorite Christmas Carols. Include lyrics in a printed program or on a screen. Choose Christmas music your group knows and enjoys.

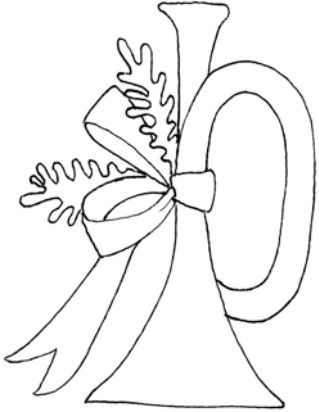

Carols

Select traditional and contemporary Christmas songs from your personal church music collection. The entire audience sings this music. Insert carols in the program wherever desired.

New Music: Merry Christ-Mess Melodies

CLOSE ENCOUNTERS MINISTRIES is pleased to present three original Christmas songs composed by Jonathan Miller, of GLORY SOUND STUDIOS in Winston-Salem, NC. Use these songs as desired (solo, group, audience, background).

Piano and lyric sheets and double channel CD (sample voice + accompaniment only tracks). Call 1-888-236-5433 or order from our website: www.cemlife.com Listen to the songs in our online Music catalog. This is an option for all groups desiring extra special music.

Special Music~Make It Personal!

Feature local church talent. These musical options are NOT in the existing program. Choose music from your own collection. Consider time limitations during planning stages. Talented people from church or community can make your program sparkle!

VOCAL SOLO
VOCAL GROUP
CHILDREN/ADULT CHOIR

INSTRUMENTAL ENSEMBLE
HANDBELL/CHIME CHOIR
INSTRUMENTAL SOLO

Stage And Props

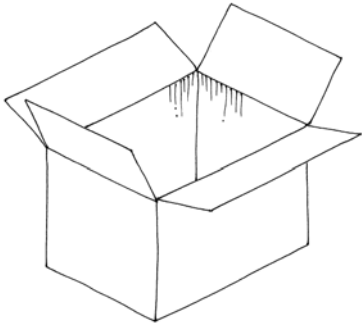

Merry Christ-Mess...Beyond Time is a unique stage presentation using a minimum of props. Small groups carry personal props with them. The stage is set simply with inexpensive, easy-to-find items and lighting. Keep it simple!

Set Up

Christmas trees, Nativity, twinkle lights, poinsettias and candles in the sanctuary add to the festive atmosphere. Leave them in place.

Staging

Your stage becomes a messy Christmas storage room. Toss labeled cardboard boxes (*see label illustration*), ornaments spilling from boxes and other Christmas related stored items around the stage. Among the closet stuff, include traditional stable items tossed in an unorganized way anywhere on stage. Make a mess!

Seating

Reserve small group seating. Assign assistants to sit with young children. Participants sit in the audience and come to the stage to present their short segment. Follow program instructions.

Sound System

Place several microphone stands across the stage. Attach personal microphones to the main speakers as desired. This detail makes the difference between a frustrating experience and a delightful program.

Lighting

Light the existing decorations. Turn off overhead lights. Place dramatic spot lights on the floor shining on the messy storage room. Dim lights behind the props gives the space a mysterious flair.

Costumes



Some participants become Bethlehem people and others wear modern clothing. Follow our suggestions for Holy Land costuming or create your own costumes for each participant.

When costuming a large group, one solution is to ask each participant to prepare their attire. Parents of young students may be willing to supply the necessary clothing.

Costume Suggestions

Pillow Cases: For small children, cut a neck hole in the pillowcase. Cut up the front to the neck hole. Cut arm holes in the sides. This makes a long, vest type costume. Sometimes plaid or striped flannel pillowcases are available and work great for shepherds and wise men.

Fabric: Two wide strips of fabric (one over each shoulder) crossed across the back and front of the person, tied with a sash makes a great costume.

Head Wraps: A square of fabric over the head with a wide ribbon or piece of cloth around the top of the head makes a headpiece.

Bathrobes: Purchase bathrobes at garage sales/resale shops. Use contrasting fabric for head pieces and sashes to complete the costume.

Angels: Dress angels in white cotton or silver lame' found in most fabric stores. Angels may wear cardboard wings or remain wingless. Place gold or silver tinsel garland taped in a circle on each angel head. Tie tinsel around the waist for a sparkling angel belt. Bare feet or sandals work great. Angels may wear face/hair glitter for that "extra sparkle".



Stars: Dress 'stars' using a handmade posterboard, glittered star draped over their neck. They dress simply in black or white slacks, leggings and simple tops. The 'stars' may wear star garlands in their hair and have a bit of glitter brushed here and there.

After The Show

Ask young participants to remain in costume at The Open Door Party. This is the time to congratulate them for a job well done and reward them with hugs and small gifts as desired.

Notes:

PREVIEW PROGRAM ONLY
NOT FOR USE
PLEASE PURCHASE

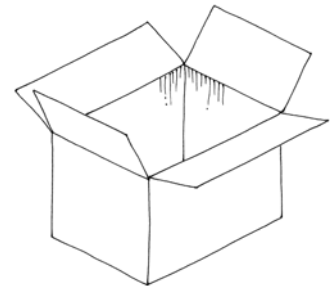

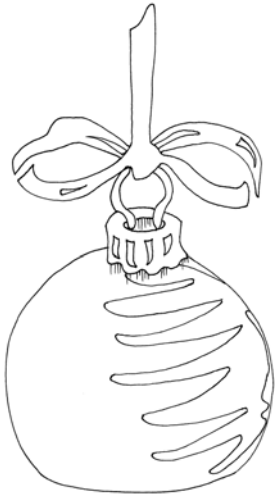

Publicity

Publicize Christ-Mess...Beyond Time through all normal church/school communication channels. Announce it in the church newsletter, the weekly worship bulletin and from the pulpit.

Bulletin and Newsletter

Inform the congregation/parents about this special Christmas event. Print an announcement in November and December newsletters. If planning *The Open Door Party*, let people know there will be a Christmas celebration including food following the program.

Local Newspaper

Include an announcement with other holiday programming publicity. Talk to a reporter and photographer to see if a feature article is possible. Be prepared to be interviewed.

Television and Radio

Advertise on your local television cable advertising channel. Radio stations often have free spots available as community service.

Christmas Card Invitations

Send family invitations home with students. This is effective for families who are not involved. Use real Christmas cards with invitations tucked inside. Children could make Christmas cards as a project and attach the invitation to be placed in their take home papers or backpack.



Christ-Mess Teachers!

Pray! Prepare! Present!

“Every child you encounter is a divine appointment.”

-Wes Stafford, Compassion International

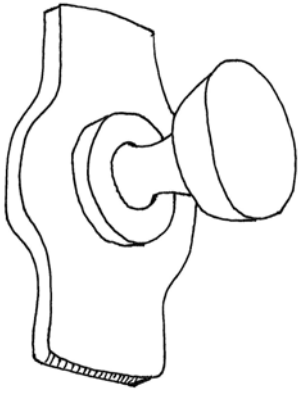

Involve As Many Students As Possible

Dress each participant in Holy Land costume and add appropriate props for their character. If modern clothing is suggested, no special preparations are needed.

Highlight Individual Parts

Be sure written material is prepared in an easily readable format.

Practice With Your Small Group

When assigned to a small group, take charge of their costumes, practice music and prepare them for the big event. Make changes as desired for your own production.

Communicate With Parents

Let parents know when to have their children at formal rehearsals and the performance. Invite them to attend and be sure they know what props or costuming their child is responsible to bring. It may be a good idea to collect items and store them in the classroom before performance day.



Smile and Help!

The Director values your leadership! Meet your small group for their entrance. Dress in appropriate costumes in a back room, line up according to specific instructions and enter the performance area as directed.

Sit with your class in the designated area. Lead them on and off stage. Perform your own part with enthusiasm. Coach students quietly if they need help.

Stage fright is not uncommon and young children are notorious for doing the unexpected. Keep that sense of humor! The audience will love whatever happens.

After The Program

Stay for the **Open The Door Party**. Collect props and program materials before your student group attends the party. Consider asking some students to remain in costume. Mingle with party goers and enjoy the experience with the cast and their families.

Notes:

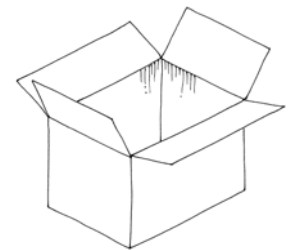

More For Teachers ~

Your Leadership Is Valued!

Show Up With A Smile!

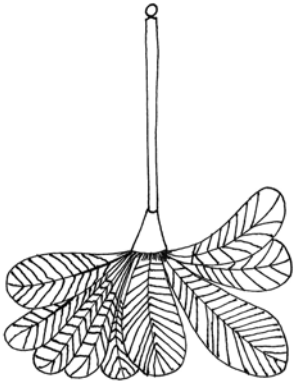

Meet your small group. Dress in appropriate costume, line up and enter the program area as directed. Sit with your group in the designated area. Lead them on and off stage. Perform your speaking part with enthusiasm. Coach students quietly if they have problems. Stage fright is not uncommon!

After The Program

Stay for The Open Door Party. Collect props and materials before attending the party. Ask students to remain in costume. Mingle and enjoy the experience with your students and their families.

If You Need Help

The Director is available but you are responsible to have your group ready to participate. The program comes together with little formal large group rehearsal.

Enjoy The Experience

This is a once in a lifetime opportunity to touch the lives of children and grown ups. Take time to enjoy your small part of the bigger picture. The Bethlehem Story is classic and life changing. The spiritual experience is amazing!



Just A Word About Memorization!



To Memorize ~

Some groups love the process of rehearsal and memorization. If that is true in your situation, take time to stage the program and memorize all parts. Consider longer lead time and more rehearsals.

Or Not To Memorize ~

We often mention that memorization is not necessary and that is true. This event is designed to be a full church, inter-generational experience. Base people organization on Sunday School groups but ask children, friends, older adults and people who may not normally participate to join the fun. It makes the event so much more fun!

If you have a limited amount of time to practice with your group, consider allowing the participants to carry their parts on stage and read them. Practice sufficiently in small group settings so that everyone is familiar with their part and can speak with enthusiasm even though reading it.

Carry printed materials on stage in creative ways. Depending on which segments are being performed, scripts can be backed with colorful paper, decorated with appropriate images.

Or, make copies of the parts that each person can hold on regular paper. After a few minutes, the audience does not notice and it does not affect the quality of the program at all.

Whatever presentation method you choose,
this is a great Christmas experience.
Have fun!

Main Characters ~



Narrator

1 Actor: Older teen or adult, female or male. The Narrator holds the program together, telling the audience behind the scenes information they would not know without explanation. This Narrator has a bad attitude issue which makes for great story telling! The Narrator stands off to one side at a podium and never leaves that spot.

Cleaning Crew

2 Actors: Older teens or adults, female, male or mixed gender become the team holding the program story together as they clean the messy storage room.

They are on stage and speak through the entire program!

Have fun becoming the harried, disgusted, puzzled, yet helpful cleaning crew. Our cleaning crew has been assigned the task of cleaning out the musty, dusty, messy Christmas storage room before Christmas. Not happy that they have to clean up the mess left by those who threw items into the room last year, they struggle to make sense of the jumble of junk.

They clean up boxes and bags of Christmas stuff. Suddenly people appear who seem surprised to be in a strange place, in a strange time in a messy room.

What the cleaning crew and audience discover is that there is much more to Christmas than the 'mess' created and tossed in a room until the next season. They discover God's message! Along the way, the audience experiences Jesus' birth through the eyes of the people who were in Bethlehem and have a story to share.



Become The Cleaning Crew

The Cleaning Crew holds the program together as the main characters who assist groups on and off stage. As small groups tell the story of Jesus' birth, the crew is first disbelieving, then amazed and then expects the unexpected from this mysterious, messy room.

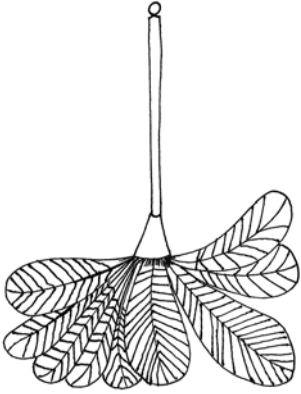

Costume: Dress in work clothing. Simple jeans and tennis shoes, full aprons and head scarves or baseball caps work great. Carry cleaning buckets filled with brushes, rags, feather dusters, etc. Carry and use a long handled push broom. Fill a water spray bottle. Spray people and stage liberally whenever appropriate!!! Have fun with it!

Hold clipboards with the full script attached. This doubles as a work order board and a 'cheat sheet' for reading lines during the entire program.

Bethlehem People

Mysterious people who appear from the back of the messy room are various small groups organized to present their segment. Follow program instructions for costuming, organization and speaking parts.

Organizing The Gang!

After reading the full program privately, chose segments according to people available in your group. From preschool to adults, include as many people as possible. Divide speaking parts between participants.

If the segment lists 10-15 speakers and you have 2 people, let them speak back and forth. If there is no one available, eliminate what is necessary. Don't worry about ages. Mix it up. The segments are flexible.

People come from the audience to perform their parts and either remain on stage as directed or return to their seats. No one waits behind stage. Everyone becomes the audience!

Choose special music presentations as desired from local talent. From children to adults, make this a fun event that includes music.



Staging Suggestions

The stage becomes a messy storage room.

Scatter large boxes, tubs and bags (*the bigger the better*) across the stage with strings of lights, old ornaments falling out of them.

An old, untrimmed Christmas tree could lean against a box or wall.

Crumple old newspaper pages and toss them around the stage.

OPTION: For fun, include the aisles where the audience enters. Scrunch up newspaper pages and toss them in the aisles.

Light and small, these little reminders of the 'mess' will not trip up guests or get in the way as the audience is seated.

Old sheets cover even more junk at the back of the stage.

Label some boxes with hand printed paper labels taped messily with any kind of tape available.

Light the messy room with small lights set behind boxes to give the stage an eerie glow.

Leave the center of the stage mess open so small groups can enter from the rear and make their way to the front as needed.

Do not purchase items but collect interesting objects to place on stage. Old Christmas decorations make the messy room complete.

Decorate using items available.

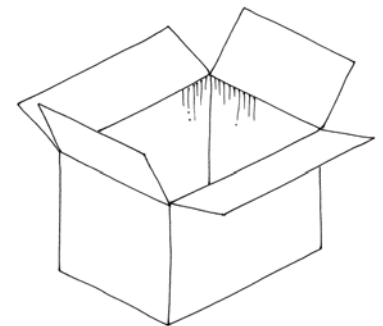
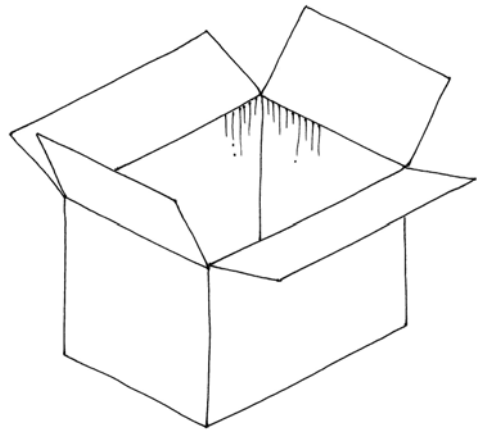

Only God Can Turn
A Mess Into A Message!

Merry
Christ-Mess!
... Beyond Time!

CANDY
CAKES

Candles

CHRISTMAS
EVENING

Shepherds

Junk

STARS

LIGHTS

COSTUMES

ORNAMENTS

DO NOT
OPEN
'TIL
CHRISTMAS



Christ-Mess At A Glance

Adapt and organize your program based on the number of available participants. Insert Christmas Carols and Special Music wherever it is appropriate. Consider the total time. Eliminate or combine segments as needed. This is a sample peek at the full event.

Prelude Processional

ACT I:

Room 211

Preschool: Church Mice
Kindergarten: Holiday Inn
Grade 1: Shepherds In Sneakers



ACT 2: Lights, Camera, Action!

Grades 2-3: Earthbound Angels
Grades 4-5: Snap, Crackle and Pop

ACT 3: It All Makes Sense

Grade 6: Meeting Jesus
Teens and Adults: Beyond Time

CONCLUSION

Only God Can Turn A Mess Into A Message

Audience Conclusion: Christmas Carols
Candle Lighting Ceremony (Optional)
Closing Prayer

IT'S TIME FOR A FANTASTIC
OPEN THE DOOR CHRIST-MESS PARTY!



Merry Christ-Mess! ...Beyond Time

Only God Can Turn a Mess Into A Message!

The Prelude

Church musicians (organ/piano/keyboard) play Christmas music as the audience gathers.

If using our original music, consider having those songs played during the prelude. The audience hears the new melodies and becomes familiar with the choruses.



The Procession

Gather costumed participants in an outer room.

Dim sanctuary lights.

Existing holiday lights are left burning.

As participants file to their seats, the audience sings a Christmas Carol of your choice. The participants may sing the theme song if you have purchased it.



Act I: Room 211

Narrator

Dress in neat, clean modern clothing. Stand at a podium at one side of the stage.

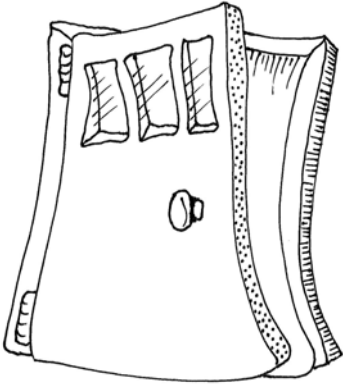

Everyone quiet down. Find a seat. I'm sure if we think our way through this logically, we will figure out a way to clean up this mess. Don't touch anything! Just sit still and think. Think. Think.

Let me introduce myself. I'm the Narrator. I'm usually in the background telling you things about the story you wouldn't ordinarily know. However, desperate times call for desperate measures. Someone has to take charge and the Narrator is the most available person. I'm the 'Narrator In Charge'.

Instead of welcoming you to our annual Christmas program, I must take a moment to apologize...deeply...for the mess. Looking around, I'm guessing that the leadership team thought that someone else was cleaning Room 211. I opened the door and a mess was waiting.

This, unfortunately, is our Christmas storage room. It should be neat, clean, serene. That's what Christmas is, right? We should be seeing angels, shepherds, wise men, a little family with a newborn baby sleeping sweetly in a manger. Oh, and with a few cuddly animals thrown in for good measure. Clean. That's what it should be...Clean.

Cleaning Crew

2 actors enter from the back of the room carrying buckets, brooms, clipboards with scripts and dressed in cleaning clothes.

Cleaner #1: *(Kicking crumpled newspaper in the aisle)*
What a mess! Doesn't anyone respect cleanliness in this day and age? What is this world coming to?



Cleaner #2: (Picking up crumpled newspaper along the way)
Somebody should post a sign, "Cleanliness is next to Godliness". That would teach 'em. Bring 'em to their knees. Why do they always call us when there's a mess in the church? I'm getting sick of it.

#1: And it's Christmas too. Don't they think we have better things to do? I have company coming, presents to wrap, a tree to trim. I don't have time for Room 211.

#2: Why didn't we check this out after Christmas last year? We should have noticed the mess then.

#1: Don't you dare blame me! I'm not the cause of this...of this...of this Christ-Mess!

#2: I was just saying....

#1: You were 'just saying'. Right! Well, I'm not going to take the blame for this. If there is going to be a Christmas program this year it's up to us to make it happen.

#2: (*Looking around the messy stage*) I doubt it. Looks hopeless to me.

Narrator: Hey! Are you the Cleaning Crew? I'm the Narrator In Charge. What's with the mess? We have an audience sitting here waiting for the Christmas program to start. They had to walk through garbage to find their seats.

#1: Don't blame us! I'm checking my clipboard right now and no one ever put Room 211 on our list. I go strictly by my cleaning list.

#2: Yep, that's the truth. We do exactly what's on the clipboard. No more and no less. Room 211 is NOT on our list! We were just saying this is some 'Christ-Mess'. (heh-heh-heh)

Narrator: Very clever. 'Christ-Mess'. However, what do you suggest I do with this audience?



#1: *(Looking into audience)* Well, you all came too early. That's all I have to say. Go home and come back later.

#2: *(To audience)* Really, Room 211 was not on our cleaning list. You can look at the list if you want to but we are telling the truth. Talk amongst yourselves and we'll get to work. We don't want to ruin anyone's Christmas.

#1: Don't say that! It's not OUR fault! This storage room was a royal 'Christ-Mess' all year. Nobody else cared about it until this very minute.

Narrator: Quit bickering and get cleaning. I'll stall the audience with my brilliant storytelling voice and vast knowledge of scripture. Hurry up because my vast knowledge of scripture may only take a few minutes to tell.

Cleaning Crew begins to move boxes, sweep, pick up junk on stage while Narrator begins the Christmas story from Luke.

(Paraphrased from Luke 1): Lots of other people have tried their hand at putting together a story of the wonderful scripture and history that took place among us, using reports handed down by the original eyewitnesses who served God with their very lives.

Since I have investigated all the reports in close detail, starting from the story's beginning, I decided to tell it to you myself so you will all know beyond the shadow of a doubt the truth of what you were told.



Preschool: Church Mice

*Preschool children birth-pre Kindergarten
participate in this segment.
Teacher speaks for the group.*



Costumes: Wear simple modern clothing with handmade mouse ears placed on heads.

Use our mouse ears illustration or design your own. Gray 2-3" wide paper head band, make gray ears with pink inserts resembling mice. The paper headbands should sit comfortably on each child's head. The 'ears' do not have to be perfect in shape or size.

Option: If desired, make long, thin tails to pin to the backs of each student. Use yarn or gray felt and a large safety pin for attaching the tail.

Preschool children enter the stage running in circles, running through the boxes, running up the aisles very quickly. They say, "Squeak, squeak, squeak" the entire time they run like little mice.

They hold their hands up like little mouse paws.

Cleaner #1: (Jumps up and down in fear while moving boxes and garbage.) Yikes! Get away from me!

Cleaner #2: Mice! Mice! Mice! They are all over the place! Get 'em! (Slap broom on floor)

Teacher: (Shouts) STOP! Nobody move!

All mice, cleaning crew, Narrator freeze in place.

These are just harmless, little church mice. They only want to talk to you about cheeses.

Cleaner #1: Cheeses?

Cleaner #2: Jesus!

Teacher: Right, Jesus! (*Gather group center stage.*) Come here church mice. Stop your squeaking and speak English. No one can understand you when you are squeaking like that. It hurts my ears.

Children: (*In unison*) We love Jesus!

Teacher: See? They are well behaved church mice who love Jesus.

Cleaner #1: (*Raising broom*) Good, good. Gather them in the same place. That way we can get them easier.

Teacher: I will NOT let you hurt these precious, little church mice. They are ready to celebrate Christmas and you are not going to ruin it for them. I just taught them how to sing "Jesus Loves Me" so they can greet the new baby Jesus. By the way, where is Jesus? Where is the stable? Where are the shepherds?

Cleaner #2: Keep practicing your song. We're not ready. You sing. We'll clean.

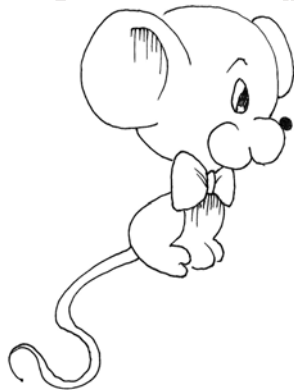

Jesus Loves Me

Jesus loves me this I know
For the Bible tells me so.
Little ones to Him belong
They are weak but He is strong.

Yes, Jesus loves me.
Yes, Jesus loves me.
Yes, Jesus loves me.
The Bible tells me so.

Teacher: I have never heard church mice sing so beautifully. It's much nicer than squeaking. I'm not feeling safe right now. Don't be tempted by cheese in snappy little trappys. Let's scurry away and see if we can find Jesus. It's His birthday and we should sing to Him.

*Teacher and church mice leave the stage
and return to their seats in the audience.*

Only God Can Turn
A Mess Into A Message!

Merry
Christ-Mess!
... Beyond Time!

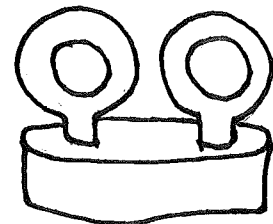
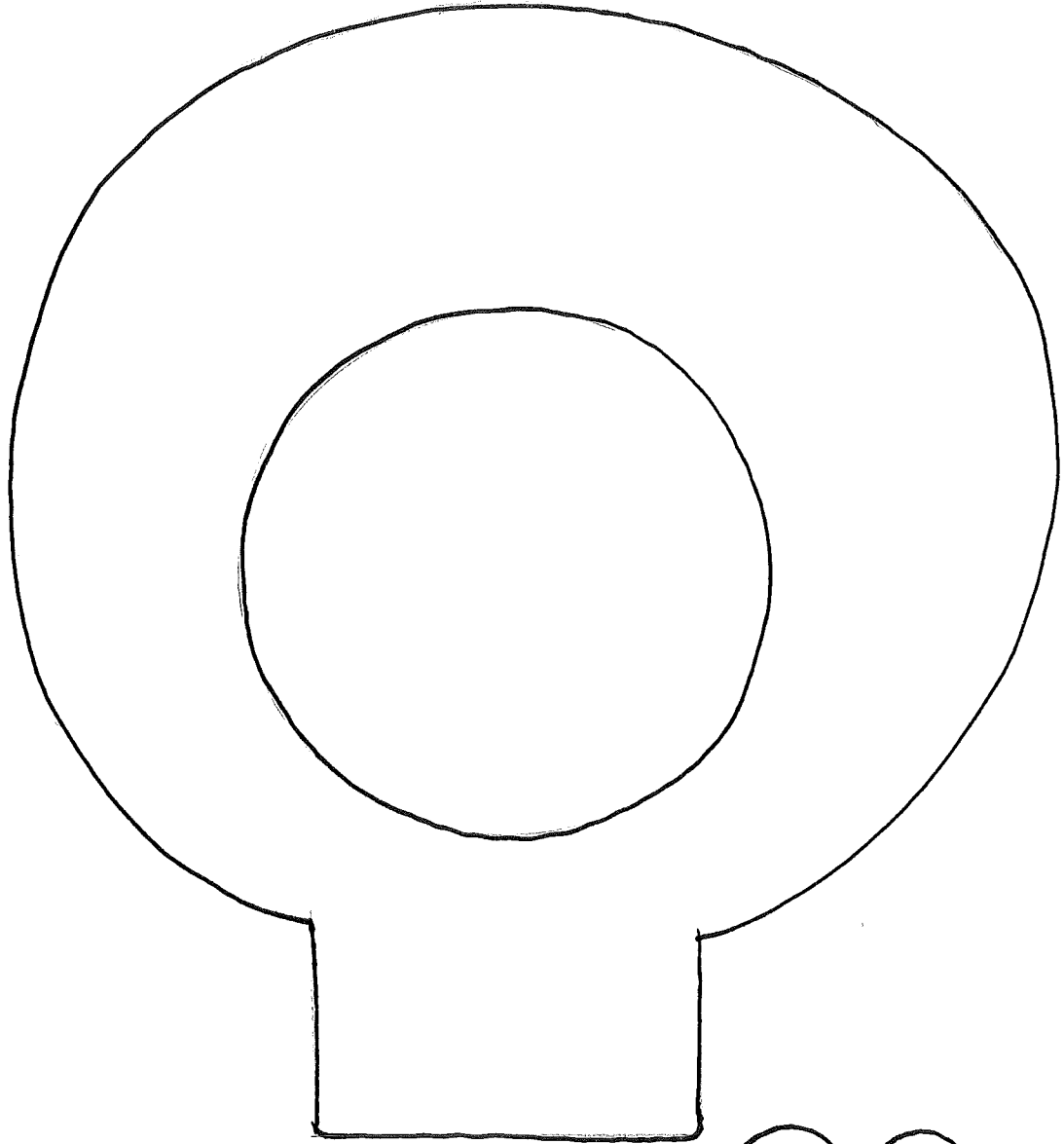

Jesus Loves Me

Andante Traditional

Piano

Je - sus loves me, this, I know, For the Bi - ble tells me so;

Lit - tle ones to Him be - long, they are weak, but He is strong.

Yes, Je - sus loves me, Yes, Je - sus loves me,

Yes, Je - sus loves me, The Bi - ble tells me so.



Elizabeth and Mary

Elizabeth: Older Woman

Mary: Young woman



Narrator

(Paraphrased from Luke 1): There was a priest named Zachariah. His wife, Elizabeth, lived with him honorably before God. They wanted a baby but they were growing older and it appeared hopeless.

Cleaner #1: *(Moving the boxes on stage.)* Stop right there. I think I found something. Wait, wait. Whoa! What in the world is happening?

Coming from behind the biggest boxes are two women dressed in Holy Land garments. They appear concerned and puzzled as they make their way through the mess to center stage.

Elizabeth: *(Wiping her hands on her dress)* What a mess! Where are we? Who are you?

Cleaner #2: Sorry! The Christmas program is delayed because the storage room *needs* to be cleaned. We're calling it a 'Christ-Mess'. Go home and come back later. Put your turkey in the oven. You have plenty of time.

Cleaner #1: Who are WE? The question is 'Who are YOU?'

Elizabeth: *(Bowing)* I am Elizabeth. Put a ...turkey...in the...oven? I have no such things.

Mary: *(Bowing)* And I am Mary of Nazareth. How did we get here? The last thing I remember is reclining for evening meal at Elizabeth and Zachariah's house in the hills of Judah.

Cleaner #2: Okay, if that's what you say. You must be method actors. Really like to get into your parts, huh? We'll go along with it. What's your story?



Elizabeth: What is my... story? I have no story. I have a miracle! I'm going to have a baby! God has given me a baby long after I ever thought I could have one. God told my husband I would have a son and we should name him John.

Mary: And I'm having a baby too! God has blessed us. I ran away to Elizabeth's house when Gabriel, he's God's angel, told me I would have a little one. Impossible, I thought, but if that's what God wants, that's what we'll do.

Elizabeth: Mary, you are so blessed among women and the baby inside you is blessed too. I don't know why God has let me be part of this wonderful plan but when you came, my baby jumped for joy!

Mary: I am bursting with God's good news! God made me the most fortunate woman on earth! It's happening ...just as God said. He has embraced Israel and piled on His mercies higher and higher. God is keeping His promise to send the Messiah.

Elizabeth: This strange place is making me frightened. Let's go home. It is time to celebrate God's great love and two baby boys!

Cleaner #1: *(Sweeping and pointing to the back of the stage)* Yeah, you do that. Go home. We'll let you know when it's time for the program. Sorry you didn't get the message!

Cleaner #2: *(Looking at the two women leaving arm in arm)* Have you ever seen those two around here before today? I know everybody in this church but I don't believe I have met them.

Cleaner #1: *(Looking at the empty stage)* Now that you mention it, I don't believe I know them. *(Shrugs and sweeps)* Oh well, they must be imports from the church down the street. It takes a lot of people to do a Christmas program. Keep sweeping. Neaten up those boxes.



Kindergarten: Holiday Inn

*Students dress in Holy Land garments.
Teacher becomes the Bethlehem Innkeeper.*

*Enter from the back of the stage. Walk through various boxes
and piles of junk on stage. Stand here and there across the stage.*



Narrator

(Disgusted) You are a patient audience. Since Room 211 is still a mess, let me continue the Bethlehem story. Volunteers who want to lend a hand can start to clean. Dust rags are available from the nearest usher. I should have gotten better janitors.

Cleaner #1 and #2: *(Together)* Hey! We can hear you!

Narrator: *(Paraphrased from Luke 2)* Ahem....About that time Caesar Augustus ordered a census to be taken throughout the empire. Everyone in the entire country had to travel to their hometowns to be counted. Joseph went from Nazareth up to Bethlehem in Judah, David's town, for the census. As a descendant of David, he had to go there. He went *with* Mary, his fiancée, who was pregnant.

Cleaner #1: I can't imagine any of the travelers were too cheerful. Walking, riding donkeys, eating dried out food. Yuck!

Cleaner #2: Wasn't there something in the story about a mean, old innkeeper who wouldn't give Mary and Joseph a room? Left Baby Jesus out in the cold to be born in a barn! I heard they even put up a sign, 'No Room at the Inn'! Some Holiday Inn. If you ask me. No Holiday. No Inn.

Cleaner #1: Mean, old innkeeper!

Innkeeper: *(Walking from behind boxes)* That would be me. Mean, old Innkeeper at your service.

Cleaner #1 and #2: *(In unison)* Oops! Sorry, guess you didn't get the message that the Christmas program is delayed. Messy room here.

Cleaner #2: *(Looking around)* Who are these tired looking people?

Kindergarten students speak their lines from various parts of the stage. Act tired, worn out and ready to stop traveling.

Student #1: I traveled to Bethlehem all the way from Jerusalem. I'm hungry and there is no food.

Student #2: I walked to Bethlehem from Bethany. Boy are my feet tired.

Student #3: *(Throw a temper tantrum!)* I want a room. I want a room. I'm in a very bad mood.

Student #4: Please? May I have a place to sleep? May I have some food? Could you give me some new clothes?

Student #5: I don't need a thing. Show me where to sign my name and I'm out of here! Bethlehem isn't my kind of town.

Student #6: *(Whine)* I don't want to wait. Ple-e-ase give me a room.

Student #7: I have extra shekels. The best room in the house for me!

Student #8: Just take care of me! Silk sheets please.

Innkeeper: See what I have to deal with every night? Me-me-me! Everyone only cares about themselves. Does anyone care about the Innkeeper? I am not mean. I am not old!

(To students) Come here and listen to my story. Closer, closer. I want to you hear this. Are you ready?

Students: *(Gather around Innkeeper. In unison)* YES!

Innkeeper: *(Shout)* I - AM - NOT - MEAN!

Students: *(Fall on floor in shock. Stay on floor to hear the story.)*

Innkeeper: *(Frustrated while explaining the situation)* I was working all day in Bethlehem's Holiday Inn...The Best Inn In Israel... minding my own business. Who arrives late last night? A young couple, strangers in town, begging for a room in the Inn. Obviously they were in Bethlehem for Caesar's census. "Count all the people", he orders. Where did he think we were going to put all those travelers? Bethlehem is just a little village where King David happened to be born long ago.

Anyway, she's going to have a baby any second and he looks like a scared rabbit. I sold the last place and didn't have one spot for them. What was I to do?

I'm mean, you say? I am offended. I did the best I could. The only place I could offer was not the perfect place for a baby to be born but it was all I had.

Did you hear me? It was ALL I HAD! I thought fast. They need someplace warm, private and dry. No prying eyes. Water and soft bedding. Then it became clear to me. They could stay in the stable with the animals.

They grabbed it fast and that's the last I heard until shepherds showed up later in the night. But that's another story!

Students: *(In unison)* Oh-h-h-h!

Cleaner #1: For a church Christmas program, you are certainly a great actor. You take everything so personally. Take these kids away and come back later. Room 211 is off limits until we get it cleaned up.

Innkeeper: *(Looking at students)* What 'kids'? There is not a baby goat in sight. Travelers, yes, kids no. We have to get back to Bethlehem. By the way, you should do something about your Inn. It's a real mess!

*Innkeeper and Kindergarten students leave
the same way they entered.*



Grade I: Shepherds In Sneakers

Students dress as Bethlehem shepherds.

Each shepherd should be barefoot.

*They walk to center stage from behind boxes
and leave the same way.*

Divide speaking parts between available students.

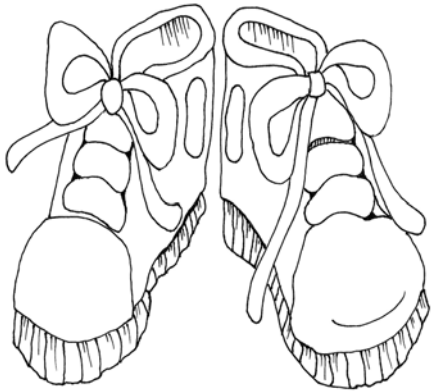

Props: Students' personal sneakers should be lined up in pairs neatly across the stage by a prop person before the segment begins.

Narrator

God could have chosen anyone in the world to announce the birth of Jesus. God had promised a Savior to Israel for centuries. He had plenty of time to think up somebody important, somebody good. Who does He pick? Shepherds.

I'm sorry but that would not have been my personal choice for the most important announcement in history. Have you ever met a Bethlehem shepherd? Not to be rude but....they stink! They can't help it. All those hours taking care of wooly, wet sheep tends to do that to a guy.

Not to mention, shepherds have horrible reputations as scoundrels and thieves. And you're telling me that God, the almighty Creator God of the entire universe, thought shepherds were the perfect people to tell about Jesus, the baby who would be our Savior?

I know I'm the Narrator but I find that very difficult to believe. I wish we could start the Christmas program. You have been a very patient audience but we appear to continue our 'Christ-Mess' in Room 211.

Student #1: *(Walking through the mess, looking around in wonder)*
Where are we?

Student #2: I knew you would get us lost. All you had to do was lead us down the hill in the dark and find the dirt path to Bethlehem. How hard could that be?

Student #3: Don't be so hard on him. We shepherds should know the way to Bethlehem without a leader. It's my bare feet that got me off track. Ouch! Those stones hurt!

Student #4: Hurry up! The angels said we have to get to Bethlehem right away. I don't want to leave the sheep alone for very long.

Student #5: I was so afraid! I didn't even hear the instructions. Where are we supposed to go? Does this place look right to you? It's an awful mess.

Student #6: Let me think. The angel said we should go to the town of David. That's Bethlehem. I'm sure of it.

Student #7: Angels! Thousands of them! I have never seen anything like that in my life. They lit up the entire hillside.

Student #8: Look around. The angel said we would find the baby wrapped in cloths, lying in a manger. The baby is the Messiah, the Lord!

Student #9: I want to see the baby, the Savior! Ouch! I can't take another step. My feet hurt.

Cleaner #1: Hi kids! Didn't you get the message? The Christmas program has been delayed? Someone forgot to clean Room 211, the Christmas storage room. We're working on it. No props until we get organized.

Cleaner #2: I found a bunch of old sneakers in a box. I've been organizing them. Grab a pair that fits you. They will make you run faster than a shepherd heading for the stable on Christmas night! Ha! Get it? See how I tied that joke right into the Christmas story?



*Students find their own sneakers, put them on
while on stage and act as if they are
the most wonderful things they have ever seen!*

Student #10: What are these ...'sneakers'? I have never seen such wondrous sandals. We can step on stones and they won't hurt our feet.

Student #11: God sent these 'sneakers'. It's a miracle! We are shepherds who wait on the Lord. We will gain new strength; We will mount up with wings like eagles. We will run and not get tired, We will walk and not become weary. (Paraphrased from Isaiah 40:31)

Student #12: Forget the stones and the fancy words, Isaiah! We are on a mission. We have to get to Bethlehem as fast as we can. Tie up the fancy sandals fast and lets get out of here!

*Students finish putting on their sneakers,
test them out by running in place.
Run off stage behind the box mess.*

Cleaner #1: I have never seen such imagination in my life. If I didn't know better, those kids actually thought they were real shepherds.

Cleaner #2: (*Sniffing the air*) Well, they had the right smell! Or else, there's another mess we haven't uncovered. Keep working. This audience isn't going to entertain itself.

*Cleaning Crew sweeps continually
while exiting the stage
by the center aisle to end Act 1.*



Time between Act 1 and 2 may be used
to sing a Christmas Carol,

perform a special musical number,

sing a song written for the program,

make announcements

or collect an offering.

You decide!

If time is short,
move into Act 2
immediately!

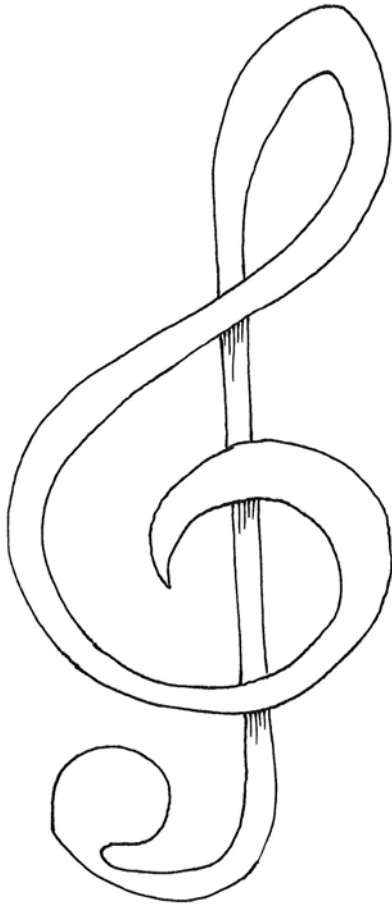

Act 2: Lights, Camera, Action!

Narrator

I see you folks stuck around waiting for the 'Christ-Mess' in Room 211 to be cleaned up. Quite the dedicated audience. If I wasn't the Narrator, I would have left long ago. Christmas is no time to hang around waiting for things to happen. We want action, right? Lights, Camera, Action. We want a show! We want to be reminded of what God did when Jesus was born in Bethlehem.

Instead, here we sit, in a messy room. And, if you ask me, it's getting a little dark and stuffy in here. The walls are closing in. The air is getting thin. I can't breathe! I...can't...breathe!

Cleaner #1: Oh stop it! Who ever heard of a Narrator with such a dramatic attitude.

Cleaner #2: Yeah, and we're getting sick of it.

Cleaner #1: Sick of it.

Narrator: Where have you been? Do you see this audience still waiting for a Christmas program?

Cleaner #2: Sounds like you are giving them quite a show so far.

Cleaner #1: We are union members. We get 10 minute breaks and a half hour lunch. We were hungry. We can't help it if the audience showed up early.

Narrator: Early! They came at the right time. The stage wasn't ready. The storage room is a mess. And, I am getting hungry myself. When do we say 'Lights, Camera, Action'?

Cleaner #1: Have you seen this mess? Not only do we have to clean it up but weird people keep coming through and messing it up more.



Cleaner #2: I have no idea how those people got in here. There is no back entrance and none of them look familiar. They almost seem to have come from somewhere...Beyond Time!

Cleaner #1: The spray cleaner is getting to you.

Narrator: Wait! We might be onto something here. Don't you think it's weird their costumes look so...so...real? And their speech. The Innkeeper thought a kid was a goat. Who doesn't know what sneakers are? But those shepherds acted like it was all new to them.

Cleaner #1: Aww, you're crazy. Maybe you should take a break and get a sandwich. We'll keep up the work here and maybe, just maybe, this audience will see something amazing.

Cleaner #2: The spray cleaner did not get to me. I'm perfectly fine. Why do you always insult me?

PREVIEW PROGRAM ONLY
NOT FOR SALE
PLEASE PURCHASE
*Cleaning Crew keeps sweeping
and moving boxes
and picking up litter.*

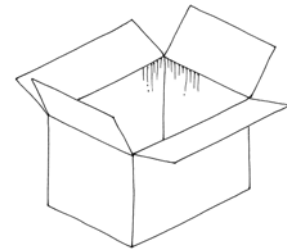

Grades 2-3: Earthbound Angels



Students dress as angels.

Enter the scene from behind boxes.

Divide speaking parts between available participants.

Props: Angels carry lit flashlights. Shine the lights around the ceiling and floor during the segment. Investigate the boxes and bags with the flashlights lit. *(Do NOT shine the lights into audience faces!)*

Student #1: *(Look around with flashlight, puzzled)* Where are we? Weren't we supposed to go straight back to Heaven?

Student #2: *(Kick a box)* What a mess! I just tripped over an old Christmas tree back there on the floor.

Student #3: *(Look at flashlight)* Why are we carrying flashlights? Shouldn't we just 'glow' naturally? Let me give it a try. *(Lift arms, bear down, scrunch up face.)*

Student #4: It didn't work. I think we are officially earthbound. Heavenly Father must have a special job for us to finish.

Student #5: I definitely heard Heavenly Father say, "Come straight Home after you sing to the shepherds". Didn't you all hear Him say that? I need to find my way out of here.

Student #6: Wasn't it beautiful? I mean after we scared the shepherds and they calmed down, wasn't it beautiful?

Student #7: My favorite part was the actual baby announcement: "Don't be afraid. I'm here to announce a great and joyful event that is meant for everybody, worldwide: A Savior has just been born in Bethlehem, a Savior who is Christ the Lord! This is what you should look for: a baby wrapped in a blanket and lying in a manger."



Student #8: My favorite part was when we all sang together. All that rehearsal paid off. We sounded terrific! I'll never forget the song.

"Glory to God in the highest
And on earth peace,
Good will toward men."

Student #9: I could sing that first part again and again, "Glory to God, Glory to God." Does my heart good to say it.

Cleaner #1: *(Still cleaning)* Did you hear something? I think I heard a bird or a bat or something that fluttered. (To audience) Did you folks hear anything?

ALL ANGELS BOW THEIR HEADS AND FOLD HANDS
LOW IN FRONT OF THEMSELVES TO TRY TO HIDE.

Cleaner #2: *(Listening)* I didn't hear a thing. Quit spraying that stuff. This mess is getting to you.

Student #10: We have to get out of here. Heavenly Father would never want us to be spotted. Hurry up. I think there's a way out the back of the room. Let's stop by the stable and take a peek at Baby Jesus. Are you all with me?

ALL ANGELS: Yes! Let's fly!

ONE ANGEL GENTLY DROPS A LIT FLASHLIGHT
ON THE WAY OUT.

Cleaner #1: Look what I found. A flashlight and it's still lit. I didn't see that here when we started cleaning.

Cleaner #2: Maybe that's the Narrator's cue for 'Lights, Camera, Action'. *(Laughing)* Sometimes I crack myself up!

Grades 4-5: Snap, Crackle and Pop

*Students dress as Wise Men in bright colors
with lots of jewelry and crowns.
Divide parts between available participants.*

Props: 3 Students carry Gold, Myrrh and Frankincense containers.

Narrator

(Ho-Hum) And now we begin our 27th hour of waiting for the Christmas program to begin. The audience is starting to nod off. The children are sleeping. It is up to me to save the program. Let me begin: Christmas in Bethlehem. The ancient dream: a cold, clear night made brilliant by a glorious star, the smell of incense, shepherds and wise men falling to their knees in adoration of the sweet baby, the incarnation of perfect love.

Cleaner #1: *(Sarcastically)* Well, that won't put them to sleep.

Cleaner #2: Oh yes it will. I can hardly keep my eyes open. Narrator, spice up the dialogue. Make it 'snap, crackle and pop'.

Cleaner #1: Hey, those are good names!

Cleaner #2: Good names for what?

Cleaner #1: Wise Men. No one ever knew their real names so that's as good as any. 'Snap, Crackle and Pop' ...three wise men who lived very long ago. That will wake up the audience!

GROUP OF WISE MEN ENTER FROM BEHIND LARGE BOXES.

Student #1: Did you hear somebody say your name?

Student #2: No, definitely not. I have no idea where we are.



Student #3: Well, that's not new. We just spent months traveling to a strange and distant land. We haven't known where we are since we left the East.

Student #4: You are so-o-o wise. It's time to get serious. The baby king has been born. We saw His star in the east. It rested over the place where he has been born and....

Student #5:and suddenly we're lost again. Just as we reach the door. We find ourselves here, in a messy place not fit for kings of the east.

Cleaners #1 and #2: *(In unison)* Hey, we heard that.

Cleaner #2: We're working on it. Will you just give us a little time. The room was a mess when we got here.

Student #6: Who is that? Anybody important? After our run in with King Herod, I don't think I can take any more tricks.

Student #7: *(Look at busy cleaners)* They look like common workers to me.

Cleaner #1: Nothing common about us! Without us Christmas doesn't happen around here. As you can tell by the audience and the mess and the Narrator who doesn't appreciate us either.

Narrator: Hey! I can hear you!

Student #8: Perhaps you can assist us. We are wise men from the east. We have traveled far to find the newborn king. Just point the way to Bethlehem and we shall leave you to your task.

Cleaner #2: I've had enough of you guys. You come in here and act like you are from another time and place. I know the Christmas story. Jesus was born in Bethlehem. When there was no room in the Inn, he was born in a stable. Shepherds got the word from angels and came running to see him. Wise men from the east brought gifts....



Student #9: (*Holding up gifts*) Gold, Frankincense and Myrrh....

Cleaner #2: I was getting to that. Gold, Frankincense and Myrrh. The Wise men's names were Snap, Crackle and Pop.

Student #10: Not true. But continue.

Cleaner #2: Who ARE you people? Why can't we have a simple Christmas program like every other year? Why do I clean and clean but Room 211 never gets any neater?

Student #11: I'm a Wise Man. I'm not a miracle worker. It appears our journey is not over. We search for a Savior, the Messiah. We leave you now in peace. Don't tell King Herod we were here.

Cleaner #1: Your secret is safe with us, mainly because nobody would believe us anyway. Who would we tell? Shalom.

Cleaner #2: Shalom? Have they gotten to you too?

PREVIEW PROGRAM ONLY
NOT FOR USE
PLEASE PURCHASE

WISE MEN BOW IN UNISON
AND LEAVE ROOM BEHIND
THE SAME BOXES WHERE
THEY FIRST APPEARED.

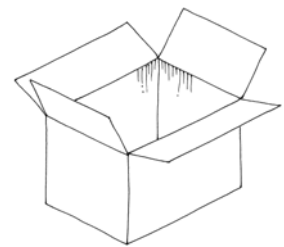

Time between Act 2 and 3 may be used
to sing a Christmas Carol,

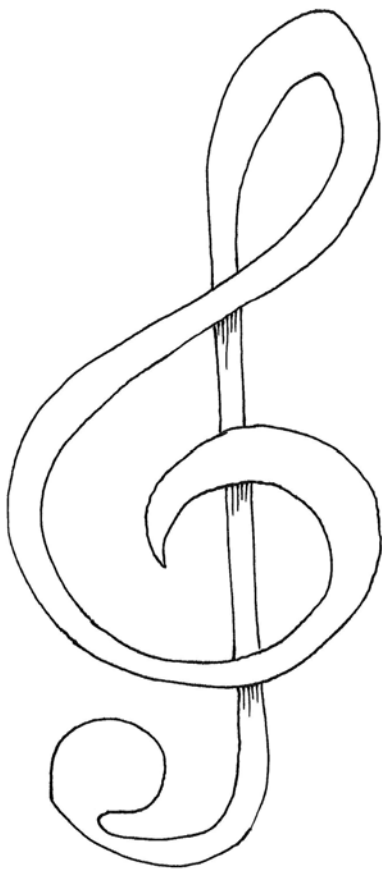

perform a special musical number,
sing a song written for the program,
make announcements
or collect an offering.

You decide!

If time is short,
move into Act 3
immediately!



Act 3: It All Makes Sense

Narrator

Something strange has occurred right here in our very own church. In the middle of our little 'Christ-Mess' crisis, we have witnessed a night of miracles. Ordinary people from another place have visited us....Beyond Time....to remind us of what God did when He planned for Jesus' birth. It was a party, a birthday party of enormous size planned to perfection by God Himself.

Who else would touch earth with angels and tell lowly shepherds to shout the news to everyone they met? While we may not think a stable is the right place for the King of kings to be born, God did and He made it so.

Cleaner #1: *(Sitting on the edge of the stage)* But why are we part of this story? We just needed to clean a messy room?

Cleaner #2: *(Sitting on the edge of the stage)* I don't know but somehow I don't think the story is done. I'm a little afraid that there are more people coming to tell their stories.

Cleaner #1: We have a job to do so let's do it. Don't be afraid. If shepherds can meet angels and not faint, we can do this. We can let Jesus' story be told again to this audience.

Cleaner #2: I'm a little nervous but if you can do it, I can do it. Narrator, is there anyone else we should see?

Narrator: I don't know. I'm only the Narrator.



Grade 6: Meeting Jesus

*Students dress in modern clothing.
They enter laughing and chatting
from the back of the center aisle.*

Divide speaking parts between available participants.



Student #1: Hey! Is this Room 211? We got a message that you were cleaning it up for the Christmas program. What happened in here? It looks like something exploded.

Student #2: We'll help you. I'll grab a broom. It won't take long. I'm supposed to be a shepherd this year. I have a costume and everything.

Student #3: What a mess! It will take you forever to get this right if we don't help.

MARY, JOSEPH
CARRYING BABY IN BLANKET
ENTER FROM BEHIND BOXES.

Student #4: No way! Who is that? Are we late? Did the program begin? We better get into our costumes!

Student #5: Wait! I want to see the baby. *(Peek inside the blanket.)* Oh my, that is one very cute baby! What's his name?

Student #6: What's his name? Duh! His name is Jesus! As in, "You will call his name Jesus, for he shall save his people from their sins." THAT Jesus!

Student #7: How can a baby do all that? Save his people from their sins! I can't even save my mom from getting a ticket when she runs a red light.

Joseph: God sent His angel to tell me this baby is special. I was afraid but proud to know God trusted me with His Son. Mary and I named him Jesus. He's tiny now but soon he will rock the world.

Mary: My baby boy will reach beyond time to change the lives of every person on earth. I don't know how we got here but I can tell you the prophet Isaiah said, "For to us a child is born, to us a son is given, and the government will be upon his shoulders. And he will be called Wonderful Counselor, Mighty God, Everlasting Father, Prince of Peace." Isaiah 9:6

MARY AND JOSEPH LEAVE
WALKING BEHIND THE
BOXES ON STAGE.

Student #8: What just happened? How did they get in here? We came here to clean Room 211. I never expected to meet Jesus!

Student #9: Meeting Jesus. Isn't that what Christmas is all about? Every single year we celebrate his birthday and call it Christmas. But the truth is, we must actually meet Jesus in a personal, down to earth way. Nothing else matters if we don't believe He is our Savior.

ALL STUDENTS: *(In Unison)* Amen.



STUDENTS LEAVE
WALKING TWO BY TWO
QUIETLY AND THOUGHTFULLY.

Surprise the audience!
Cleaning Crew push boxes and bags
to the edges of the stage.
Costumed children from previous segments
return silently and take their places
in the Nativity scene.



PREVIEW PROGRAM ONLY
NOT FOR USE
PLEASE PURCHASE

If there are too many participants in each small
group, choose a few representatives to be
shepherds, angels, wise men. Include the
littlest children dressed as travelers by seating
them on the floor at the front edge of the stage,
looking on as a mini audience.

Mary, Joseph and Manger
are the centerpiece.

Add Elizabeth and the Innkeeper
watching from the side.

Teens and Adults: Beyond Time

*Teens and Adults dress in modern clothing.
Stand here and there among the Nativity people
who are silent and ignore the strangers in their midst.
Divide speaking parts between available participants.*



Student #1: Here we are, in the place where history changed forever. Who could have imagined we would experience that place on that night with these people?

Student #2: *(Looking around in wonder)* I cannot believe I am here. What is it about Room 211 that is so different from any other room in the church? It's a mess and yet....

Student #3: ...and yet it is so real. A storage room that appears to be a 'Christ-Mess' but tells the real story of the day Jesus was born.

Student #4: *(Stand near shepherds)* These Bethlehem **Shepherds** lived out their lives knowing God spoke to them from beyond time. After this night, after seeing Baby Jesus, I cannot imagine what they told everyone they met. Did those people believe them?

Student #5: *(Stand near angels)* Talk about God touching earth from beyond time. **Angels** must have been excited to be included in the party at Bethlehem. Much later Peter said, "These things, which even angels long to know, have now been proclaimed to you by those who brought you the good news." (1 Peter 1:12)

Student #6: *(Stand near kneeling wise men)* The **Wise Men** found Him! After all that travel, danger and mystery, God reached beyond time and led them to the stable. 'Now after Jesus was born in Bethlehem of Judea in the days of Herod the king, behold, wise men from the East came to Jerusalem, saying, "Where is He who has been born King of the Jews? For we have seen His star in the East and have come to worship Him." Not only did they find Jesus but they also provided the three gifts of gold, frankincense and myrrh that would sustain the little family financially while they lived in Egypt.



Student #7: (*Stand near Mary*) Look at her. A girl named **Mary**. Just a simple, ordinary girl really. God watched her from beyond time and saw a girl who lived with a sense of God's presence in her life. The Lord was with her. She enjoyed a beautiful moment-by-moment fellowship with God.

It was shocking and frightening when Gabriel appeared but she trusted that if God was in it she would win it. Mary's story didn't end in this stable. She saw Jesus' life unfold beginning to end. It was as if she was a watcher from the sidelines. The joy and favor she felt in Bethlehem would turn to grief at a Roman cross outside Jerusalem just 33 years later. But for this one night, Mary is reaping the reward of complete trust in her Heavenly Father.

Student #8: (*Stand near Joseph*) Look at him. A young man named **Joseph**. His plan was to grow up, get married, have a family and be a carpenter. Nothing more, nothing less. He knew his destiny.

Instead, God saw his faithfulness and said, "I have a better plan for you, Joseph." There were all kinds of craftsmen in the land. Potters, weavers, blacksmiths and carpenters. The most momentous events of all human history were to involve the people associated with that humble carpenter shop in Nazareth.

I imagine that if you asked Joseph right now if he thought he was good enough and smart enough to protect and raise Jesus, the Messiah and Savior of the world, he would say, "Not me. Pick someone else. I'm just a carpenter." But that's not how God saw Joseph. So, from beyond time, God touched the heart of a young man to love a young girl and raise a Savior to manhood.

Student #9: (*Stand near the Innkeeper*) The Bethlehem **innkeeper** has been getting a bum rap. He has become the victim of cheap shots by preachers, teachers and pageant writers. The Bible does not accuse the innkeeper. Joseph did not complain to the innkeeper. Mary did not complain about the innkeeper.



The inn was no Holiday Inn. It was a place where the masses gathered; ruffians, thieves, heavy drinkers and rowdy men. There would have been no soft straw bed. Mary would have only had a hard floor. The innkeeper's stable was private where no one would overhear her birth pangs.

The stable was safe, secure and warmer than the inn. There was no fear of a knife at one's throat in the night and a voice saying, "give me your tax money or I will take your life."

So God reached beyond time and the innkeeper cooperated to provide a perfect place for Jesus to be born—a safe, quiet, soft, warm, perfect place. And besides, this often hated innkeeper of Bethlehem had given the best that he had—and that is all that is asked of any of us.

~Taken from article by Paul Harvey

Student #10: *(Stand near Elizabeth)* By far the oldest person in the story of Bethlehem, **Elizabeth**, was not even there to help when Jesus was born. She was busy with her own baby boy, John, by then. Look at her. She stands here beaming. I'm sure Mary told her every detail of the adventure in Bethlehem while cousins, John and Jesus, played at their feet.

We know for a fact that God reached beyond time and touched Elizabeth in her old age. Her desire to have a child was strong but there was no anger or bitterness toward the Lord because she did not have a child. She had a strong relationship with the Lord.

Long after this Bethlehem stable night, John took his rightful place as God intended to herald the arrival of the Messiah. John said, "Repent, for the kingdom of heaven has come near." John was the person old Isaiah called, "A voice of one calling in the wilderness, 'Prepare the way for the Lord, make straight paths for him'".

ALL NATIVITY PEOPLE LEAVE THE STAGE QUIETLY.
TEENS AND ADULTS REMAIN ON THE STAGE ALONE.



Student #11: Where are they going? Wait! Don't leave! We have so many questions to ask. Are you real? What happens next? We need to know!

Student #12: (*Holding open Bible*) I know what happens. I've read the Book. It seemed so odd that I never saw this room before and I have come to this church all my life. Room 211. Look what I found in God's Word: "For unto you is born this day in the city of David a Savior, which is Christ the Lord." LUKE 2:11

Student #13: Luke 2:11! Room 211. Why didn't we get it? We were so busy looking at the mess that we forgot the message. God is reminding us that only God can turn a mess into a message.

TEENS AND ADULTS LEAVE THE STAGE
AND RETURN TO THEIR SEATS.

PREVIEW PROGRAM ONLY
NOT FOR USE
PLEASE PURCHASE

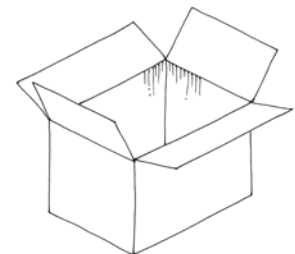

Conclusion: Only God Can Turn A Mess Into A Message

Narrator and Cleaning Crew

Narrator

Well, we finally got our act together to give you, our faithful and true audience, a Christmas program this year. It was touch and go for awhile but that's the way it goes. The story of Jesus has been told again within our hearing. It is an old story. It is comforting to re-live it. We need to hear it every year...to stop the hustle and bustle of our lives. It's true. Only God can turn a mess into a message!

Cleaner #1: I can handle the 'hustle'. It's the 'bustle' that really gets to me every Christmas. I didn't think we would pull it off. This Christ-Mess was overwhelming.

Cleaner #2: Do you think God gave us a special moment to see what He did that night? I thought we were just cleaning up a messy room but so much more happened here. I think Jesus has been here.

Narrator: Look behind you.

CLEANING CREW DISCOVERS A MANGER
HAS BEEN LEFT BEHIND ON STAGE.
CARRY IT TO CENTER FRONT STAGE.

Cleaner #1: That's odd. I don't remember this container being here earlier. It's a manger, like the one we use for every Christmas program.

Cleaner #2: So it is. Why didn't we see it before? Sort of fits with all the other strange happenings in Room 211.

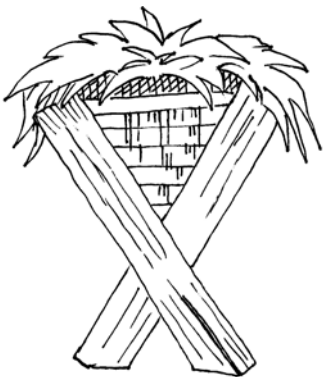

Cleaner #1: I could never figure out why God allowed Jesus to be placed in a manger. An animal food dish. It's sort of like putting a baby in a dresser drawer.

Cleaner #2: We'll never know....at least we'll never know this side of Heaven.

Narrator: Jesus. There's something about that name. I believe we have been part of a Christmas miracle, my friends. We'll never see anything like this again.

Cleaner #1: (Looking in manger) What's that? It looks like there's something in the manger. What is it?

Cleaner #2: (Pull out a note. Words are printed on a large piece of paper. If desired, sprinkle with glitter so the paper shines in stage lighting.) Only God can turn a mess into a message. I think I found a message. Should we read it? (Smile as you read it silently) You won't believe what it says. Look! Read this.

Cleaner #1: (Reading) "I'll be back!"

PLEASE PURCHASE

CLEANING CREW LEAVES STAGE
BEHIND THE BOXES AND BAGS
THAT ARE THE 'CHRIST-MESS'.

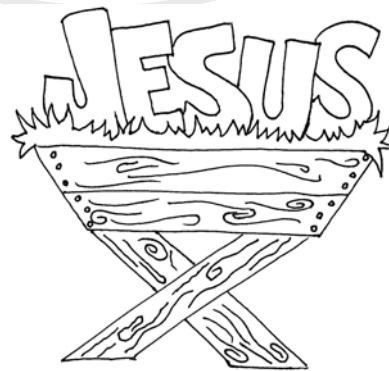

Audience Conclusion

Sing a favorite selection of
Christmas Carols.

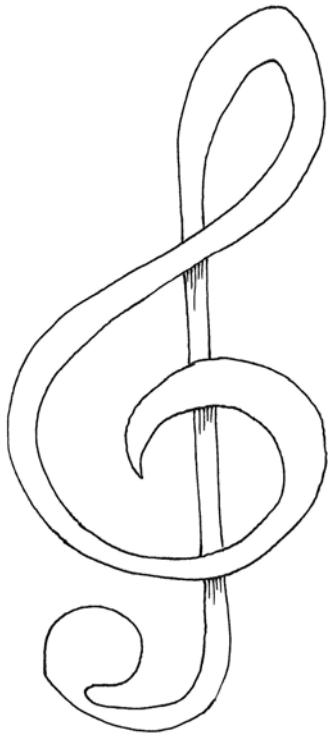

Ask the pastor
to lead an inspiring
Candle Lighting Ceremony.

Close In Prayer.

Dismiss audience to the
OPEN THE DOOR Party!



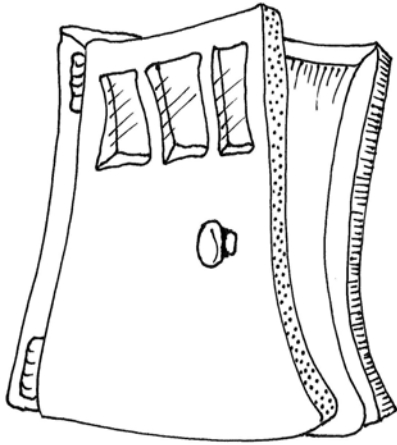

Open The Door Party!

Assign party planning to one small group. This may be a few men and women hand picked for this purpose or and adult Sunday School class or women's group.

Offer delicious food, background Christmas music and casual fellowship.

Preparations Before Party Day

Menu: Plan the menu. A pleasant option may be to ask people to bring their favorite Christmas dessert to share. Provide a variety of beverages.

If this is a Sunday morning event, consider serving a Continental Breakfast complete with doughnuts, orange juice, coffee and tea.

Seating: Decide the best arrangement for seating depending upon the size of the anticipated gathering. Position tables and chairs and serve buffet style with guests standing and moving around the room to chat. Place a few chairs in small circles throughout the area for small group conversation.

Music: Fill the room with Christmas music. This could be live music performed by local church musicians or favorite CD performances.

Centerpieces: Cover tables as desired. Feature Christmas centerpieces on each table. Add door related items. Old door knobs, light switches and hand printed copy of John 10:9 "Jesus said, I am the Door. By Me if anyone enters in he shall be saved."

Preparations On Party Day

Decorate the serving table and guest tables. Plug in the coffee pot and put tea water on the stove to boil while the program is in progress. Set out desserts, cream and sugar. Make your favorite Christmas punch and place on a nearby serving table.

During The Party

Assign people to cut and serve desserts, pour beverages and refill creamers and sugar bowls as needed. Greet guests cordially as they come through the serving line. Move about the group to be sure everyone feels welcome. Find seats for those who may not be familiar with your church. Introduce people. Enjoy the program participants as they mingle with the guests.

After The Party

The party is not over until clean up is complete. Ask everyone to help with dishes, removing tables and chairs and sweeping the area clean.

Go Home to Keep Christmas
With Your Families
Knowing you have been
Good and Faithful Servants!

Merry Christ-Mess!



Only God Can Turn
A Mess Into A Message!

Merry
Christ-Mess!
... Beyond Time!

PREVIEW PROGRAM ONLY
NOT FOR USE
PLEASE PURCHASE

