

RT 55 / PD
55 LBS THRUST
12 VOLT 50 AMPS
48" SHAFT

for use with "AG" serial numbers
3-year warranty from the date of purchase

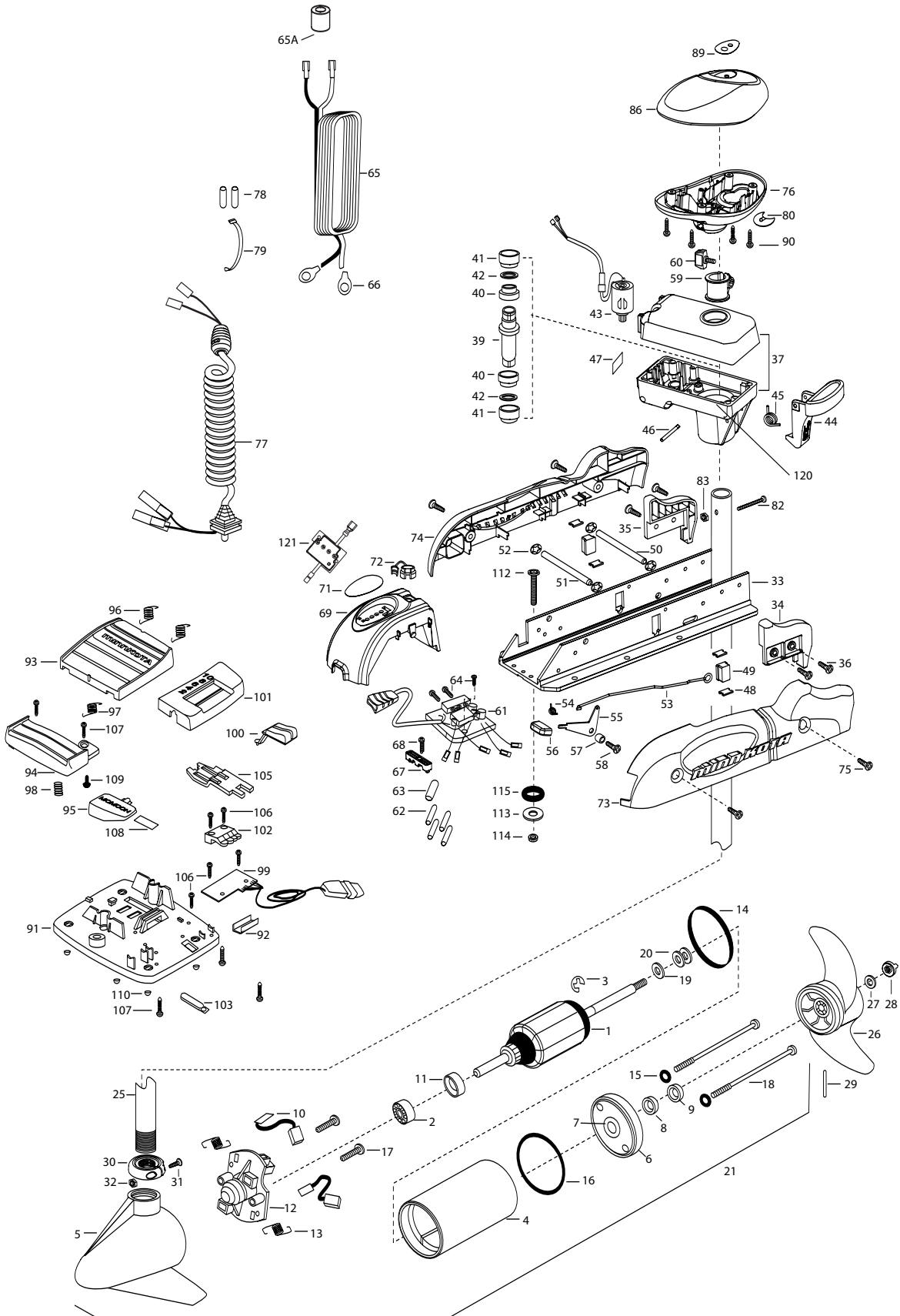

1	2-100-115	ARMATURE ASSEMBLY	*42	2304603	O-RING [2.EA]	86	2300243	CONTROL BOX COVER- RIPTIDE WHITE
2	140-010	BALL BEARING	43	2307045	MOTOR- DRIVE HOUSING HIGH SPD	89	2315676	DECAL- COVER ON/OFF 55PD
3	788-015	RETAINING RING	44	2307215	LATCH HANDLE PD/AP	90	2372100	SCREW-8-18 X 5/8 SS [4.EA]
4	2-200-301	HOUSING ASSEMBLY CENTER 3.62 W/MA	45	2302750	SPRING- LATCH TORSION PD/AP	■	2774700	FOOT PEDAL ASSEMBLY
5	421-336	HOUSING BRUSH END 3.62 WHITE	46	2302626	PIN- ROLL 3/16X2 SS	91	2304511	FOOT PEDAL BASE
6	2-400-337	PLAIN END HOUSING ASSEMBLY 3.625	47	2305515	DECAL-STOW/DEPLOY PD/AP'2001	92	2308500	WEAR PLATE FOOT PDL
7	144-049	BEARING - FLANGE (SERVICE ONLY)	48	2335110	PAD-PIVOT SUPT SS [4.EA]	93	2304516	FOOT PEDAL-UPPER
8	**880-003	SEAL	49	2305103	PIVOT PAD [2.EA]	94	2304520	FOOT PEDAL-LOWER
9	**880-006	SEAL WITH SHIELD	50	2330510	PIN-LATCH PD BASE SS	95	2307210	LEVER MOM/CON-
10	188-036	BRUSH ASSEMBLY [2.EA]	51	2330520	PIN-PIVOT PD BASE SS	96	2302730	SPRING-LONG-UPPER PEDAL [2.EA]
11	725-050	BRUSH RETENTION- PAPER TUBE	52	2333100	NUT-SPEED SS [4.EA]	97	2302731	SPRING-SHORT-UPPER PEDAL
12	738-036	BRUSH PLATE W/HOLDER	53	2303612	ROD-RELEASE RT/AP SS	98	2302732	SPRING-LOWER PEDAL
13	975-040	SPRING - TORSION [2.EA]	54	2302700	SPRING-RELEASE LEVER	99	2304012	CONTROL BOARD ASSEMBLY-FT PDL
14	**337-036	GASKET	55	2333705	LEVER-RELEASE SS	100	2300120	KNOB-SPEED SELECTOR
15	**701-008	O-RING, THRU-BOLT [2.EA]	56	2300101	RELEASE-KNOB	101	2300121	HOUSING SPEED SELECTOR
16	**701-081	O-RING	57	2301700	SPACER-RELEASE LEVER	102	2302840	ACTUATOR-BOARD
17	830-007	SCREW-8-32 [2.EA]	58	2332104	SCREW-1/4-20 X 5/8 SS	103	2302841	ACTUATOR-MOM/CON
18	830-042	THRU-BOLT 10-32X8.83 [2.EA]	59	2031522	COLLAR- DRIVE (W/INSERT)	105	2302842	ACTUATOR-STEERING
19	990-067	WASHER- STEEL THRUST	60	2011366	SCREW-COLLAR/NEW KNOB SS	106	2302100	SCREW-6-20 X 1/2 [5.EA]
20	990-070	WASHER - NYLATRON [2.EA]	61	2304041	CONTROL BOARD ASSEMBLY- 12V PD/AP	107	2372100	SCREW-8-18 X 5/8 [5.EA]
21	2097100	MOTOR ASSMBLY 12V 3.62VARS SW/WHT	62	2305410	SHRINK TUBE-.314 X 2.25 [4 EA.]	108	2266610	DECAL-ON/OFF SWITCH
25	2032021	TUBE-COMPOSITE 48" AP/WHITE	63	2305401	SHRINK TUBE-.374 X 1.50 [4 EA.]	109	2335130	BUMPER ACTUATOR
	2032022	TUBE-COMPOSITE 54" AP/WHITE	64	2332100	SCREW-8-32 X 3/8 [3.EA]	110	2994807	BAG ASSEMBLY- 4 RUBBER BUMPERS
■	1378131	PROPELLER KIT	65	2090651	LEADWIRE IOGA 44"	■	2994812	BAG ASSEMBLY- (BOLT,NUT,WASHERS)
26	2091160	PROPELLER W/WEDGE 2	66	2020700	TERMINAL RING [2.EA]	*112	2333500	BOLT-MOUNTING-SS [6.EA]
27	2151726	WASHER-5/16 SS	67	2222906	STRAIN RELIEF- BRACKET PD/AP	*113	2151726	WASHER-5/16 SS [6.EA]
28	2198400	ANODE- ZINC 3.25/3.625 LWR U	68	2332104	SCREW-1/4-20 X 5/8 SS	*114	2383106	NUT-5/16-8 MOUNTING SS[6.EA]
29	2092600	PIN-DRIVE	69	2306556	HOUSING- CENTER PD/AP WHITE	*115	2301720	WASHER-MOUNTING RUBBER [6.EA]
30	2301555	COLLAR- LATCH PD/AP	71	2306614	DECAL- BATT GAUGE H RT AP	120	2304604	O-RING CASE SEAL
31	2303434	SCREW- 8-32X5/8 MACH PHCR	72	2302935	STRAIN RELIEF-DR. HOUSING	121	2074080	BATTER METER
32	2303112	NUT 8-32 NYLOC SS	73	2303944	SIDEPLATE (RIGHT) WHITE			
33	2301933	EXTRUSION- BASE ANODIZED	74	2303949	SIDEPLATE(LEFT) WHITE			
34	2303932	MOTOR REST- RIGHT LARGE	75	2332104	SCREW-1/4-20 X 5/8 SS			
35	2303937	MOTOR REST- LEFT LARGE	76	2772516	CONTROL BOX / DECAL ASSEMBLY			
36	2332104	SCREW 1/4-20X5/8 SELF TAP SS [4.EA]	77	2991280	COIL CORD WSTRAIN RELIEF 48"			
37	2301847	DRIVE HOUSING AP SW WHITE	78	2305402	SHRINK TUBE .374 X 2.25 [2 EA.]			
■	2882011	BUSHING/ OUTSHAFT KIT (INCLUDES 39-42)	79	9950433	TIE WRAP-4" BLACK			
*39	2302010	DRIVE HOUSING OUTPUT SHAFT	80	2224701	INSERT- PLUG WHITE			
*40	2307304	BUSHING- INNER [2.EA]	82	2332102	SCREW-10-24 X 1-3/4			
*41	2307305	BUSHING- OUTER [2.EA]	83	2333101	NUT-HEX 10-24 NYLOC			

**Seal & Oring Kit P/N 2888460

* This item is part of an assembly. This item cannot be sold separately due to machining and /or assembly that is required.

P/N 2314943

REV.A 9-05

