

**Part Number: PTR07-47100**

**Kit Contents**

Item #	Quantity Req'd.	Description
1	2	Front Springs
2	2	Rear Springs
3	2	Nuts
4	1	Instruction Form

**Hardware Bag Contents**

Item #	Quantity Req'd.	Description
1		
2		
3		

**Additional Items Required For Installation**

Item #	Quantity Req'd.	Description
1	PTR07-47100-AA	Spring Spacer (4 required) (Port Processing Only)
2	Nylon Tie	8-1/2" L, 0.30" W, 120# Tensile Strength
3		

**Conflicts**

None
------

**Recommended Tools**

<b>Personal &amp; Vehicle Protection</b>	<b>Notes</b>
Fender Covers	2
Safety Glasses	
<b>Special Tools</b>	<b>Notes</b>
Wall mounted spring compressor	
Tall Jack Stand	
<b>Installation Tools</b>	<b>Notes</b>
Torque Wrench	3/8 & 1/2 drive
Sockets 3/8" drive	10, 14, 17mm
Sockets 1/2" drive	17, 19, 21, 22mm
1/2" Impact Gun	Only for removing fasteners
3/8" Air Ratchet	Only for removing fasteners
<b>Special Chemicals</b>	<b>Notes</b>
None	

**General Applicability**

Prius Sedan
-------------





**Recommended Sequence of Application**

Item #	Accessory
1	PLUS Springs
2	PLUS Rear Sway Bar
3	

**Vehicle Service Parts** (may be required for reassembly)

Item #	Quantity Req'd.	Description
1	2	90177-14005 Nut, Front Shock
2		
3		

**Legend**

	<b>STOP:</b> Damage to the vehicle may occur. Do not proceed until process has been complied with.
	<b>OPERATOR SAFETY:</b> Use caution to avoid risk of injury.
	<b>CAUTION:</b> A process that must be carefully observed in order to reduce the risk of damage to the accessory/vehicle and to ensure a quality installation.
	<b>TOOLS &amp; EQUIPMENT:</b> Used in Figures calls out the specific tools and equipment recommended for this process.
	<b>REVISION MARK:</b> This mark highlights a change in installation with respect to previous issue.

Care must be taken when installing this accessory to ensure damage does not occur to the vehicle. The installation of this accessory should follow approved guidelines to ensure a quality installation

These guidelines can be found in the "Accessory Installation Practices" document.

This document covers such items as:

- Vehicle Protection (use of covers and blankets, cleaning chemicals, etc.).
- Safety (eye protection, rechecking torque procedure, etc.).
- Vehicle Disassembly/Reassembly (panel removal, part storage, etc.).
- Electrical Component Disassembly/Reassembly (battery disconnection, connector removal, etc.).

## 1. REMOVE COWL



- (a) Install brake jack tool (if available).
- (b) Raise hood.
- (c) Place fender covers over fenders.
- (d) Remove wiper arms.
  - (1) Remove wiper arm head caps with nylon pry tool or pull off with fingers. (Fig. 1-1)
  - (2) Remove nut and pull wiper arm off of wiper drive stud. (14mm)
- (e) Remove cowl side ventilator sub-assemblies
  - (1) Using a screwdriver, disengage the claw and guide <A> as shown in the illustration.
  - (2) Disengage the guide <B> and remove the cowl side ventilator sub-assembly LH as shown in the illustration.

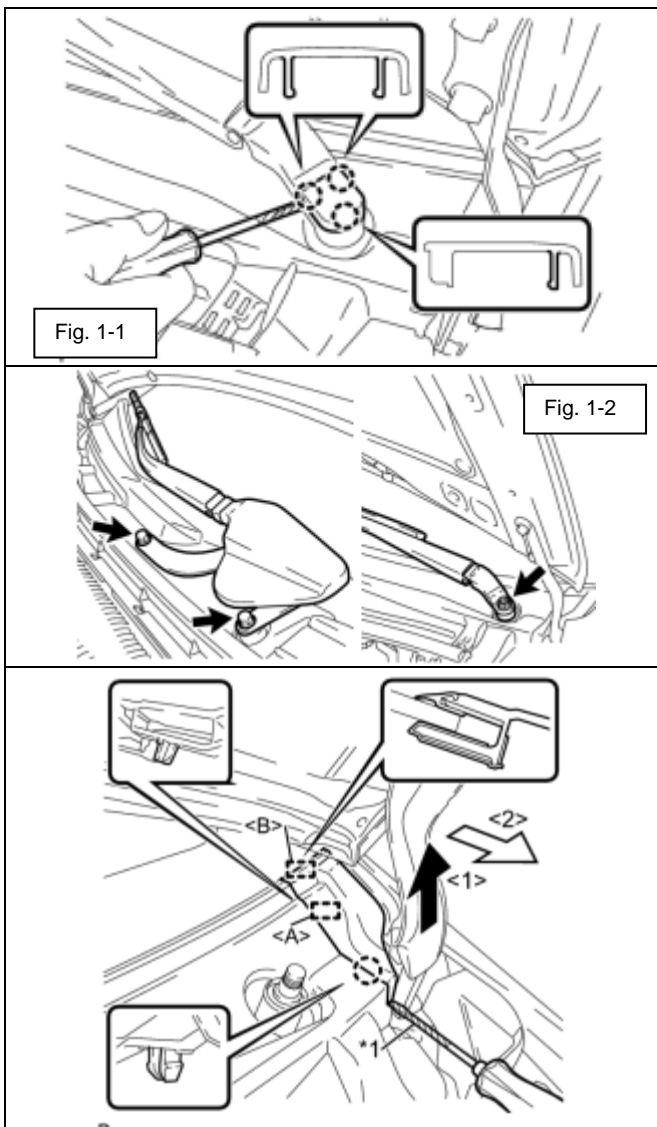

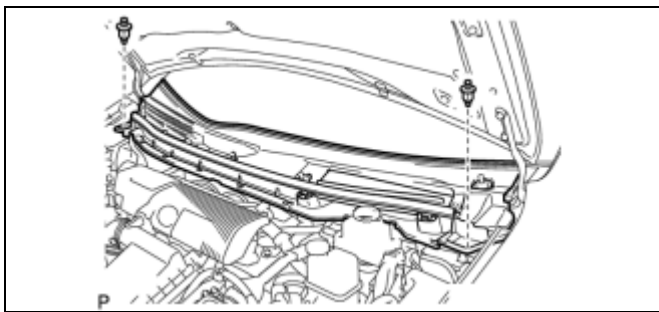

- (f) Remove cowl cover.
- (1) Remove the 2 clips.
  - (2) Disengage the 5 claws and 3 guides <A>.
  - (3) Pull out the cowl top ventilator louver sub-assembly as shown in the illustration.

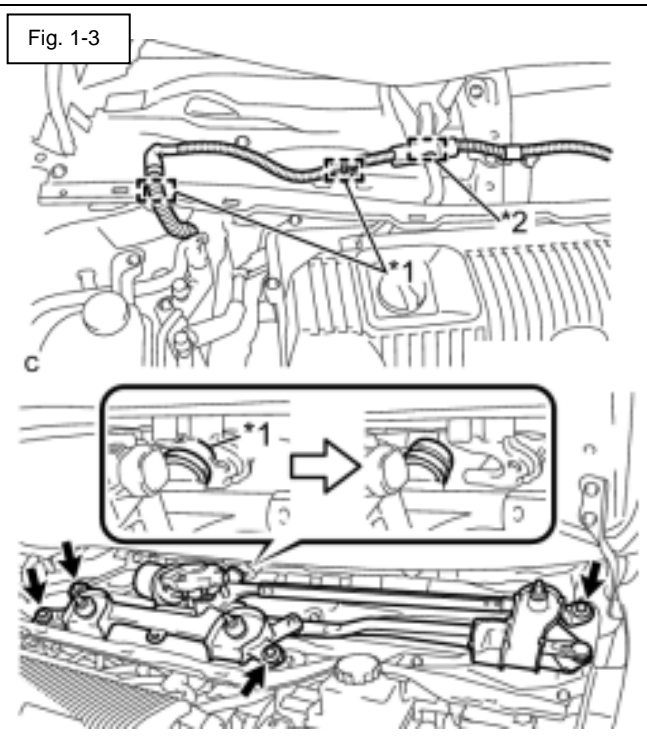
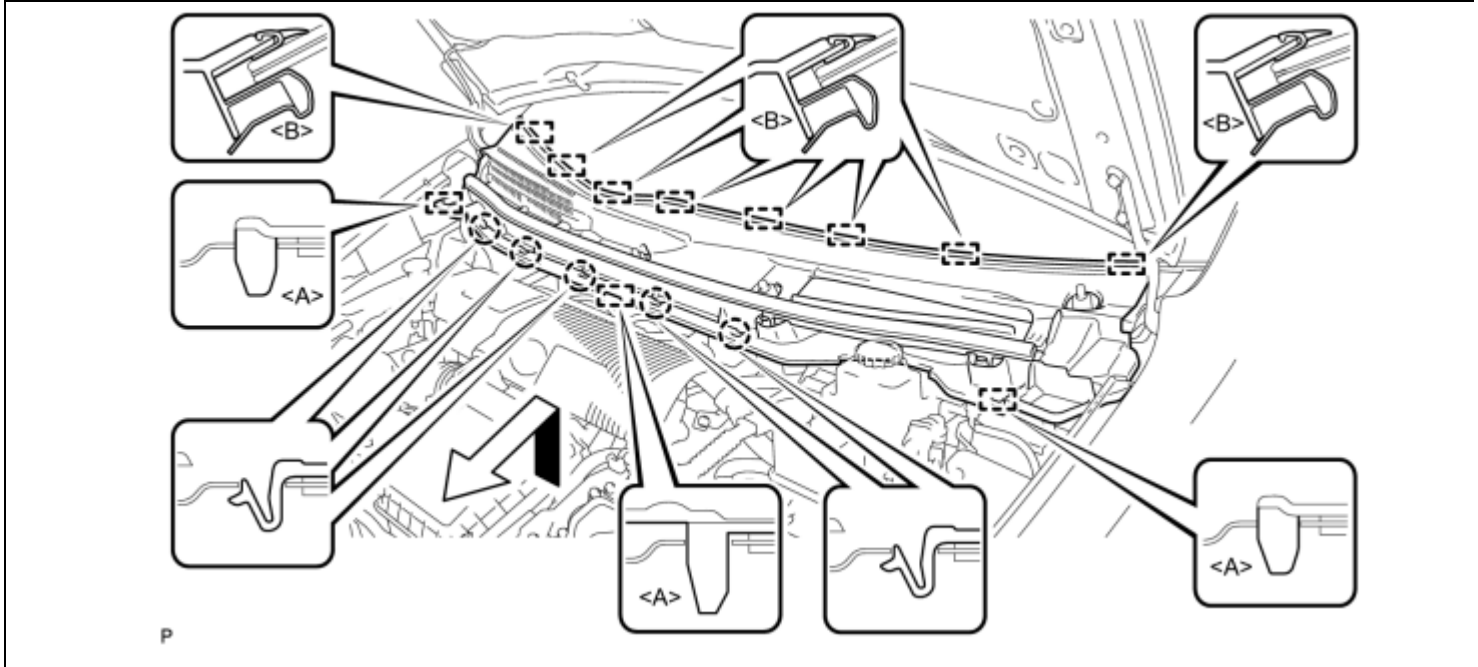

- (g) Protect lower edge of windshield from your tools using tape or rubber protector.



- (h) Remove two wire harness plastic fasteners \*1 using a small screw driver.
- (i) Move wiper link / motor assy.
  - (1) Remove screws (4). (🔩10mm)
  - (2) Slide assembly to the right disengaging the rubber locating grommet.
- (j) Place wiper motor assembly on a protective pad or blanket on top of the engine.
- (k) Remove cowl pan. (🔩10mm)

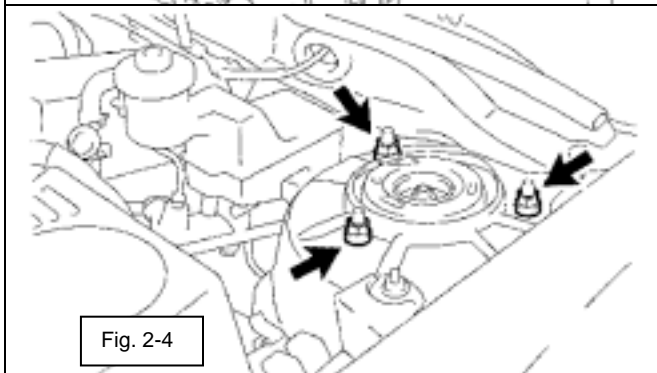
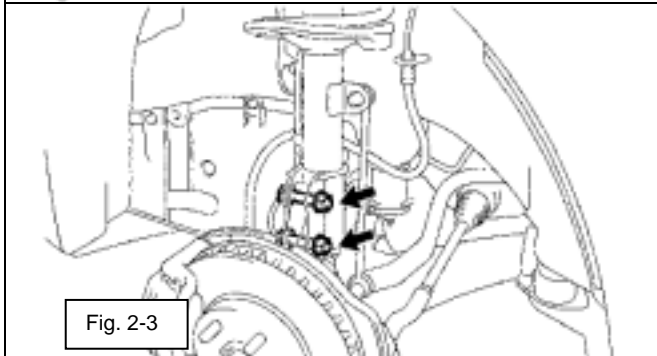
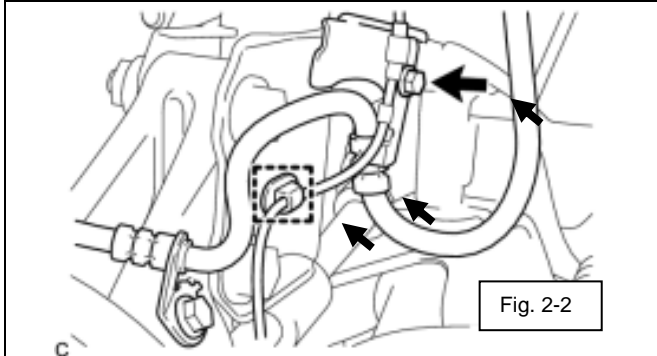
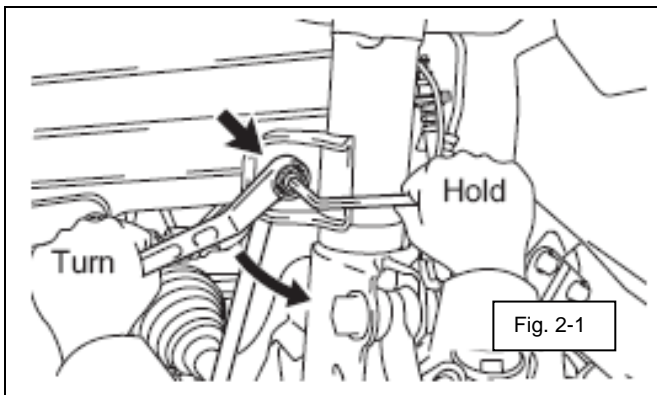

## 2. REMOVE FRONT STRUT ASSEMBLY

- (a) Remove front wheels. (🔑21mm)
- (b) Separate front stabilizer link from the strut assy. If the ball joint spins use a 🔑6mm allen wrench to hold the center stud in place. (Fig. 2-1) (🔑17mm)
- (c) Separate front flexible hose and speed sensor wire. (Fig 2-2)
- (d) Disconnect strut assy from knuckle. (Fig 2-3)
  - (1) Take careful note of the orientation and location of these bolts so that they can be installed the same way they were removed. (🔑22mm)
- (e) Remove strut assy.
  - (1) Loosen the 3 nuts fastening the strut to the fender apron. (Fig 2-4)(🔑14mm)
  - (2) Supporting the weight of the strut assy remove the top nuts by hand and pull the strut assy out of the wheel well.



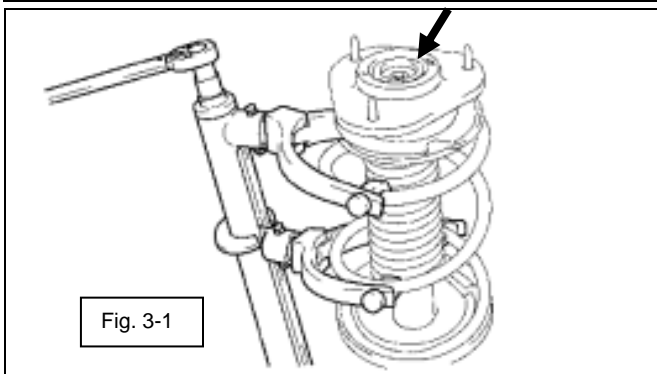

### 3. STRUT DISASSEMBLY

- (a) Compress spring in spring compressor.
- (b) Remove upper nut, coil spring seat, bumper, and insulator. (Fig. 3-1) (19mm)
- (c) Remove original spring.

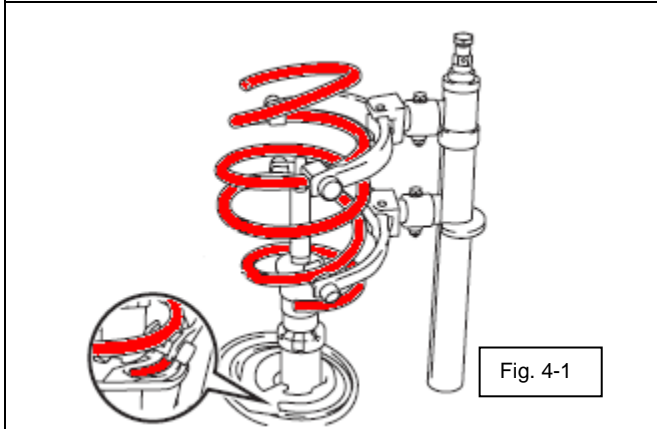

### 4. ASSEMBLE STRUT

- (a) Install front TRD spring. (Fig. 4-1)
  - (1) Spring wrap with the slightly smaller diameter should be installed in the upward direction, TRD should read right side up.
  - (2) Fit the lower end of the coil spring into the pocket of the shock absorber lower seat.

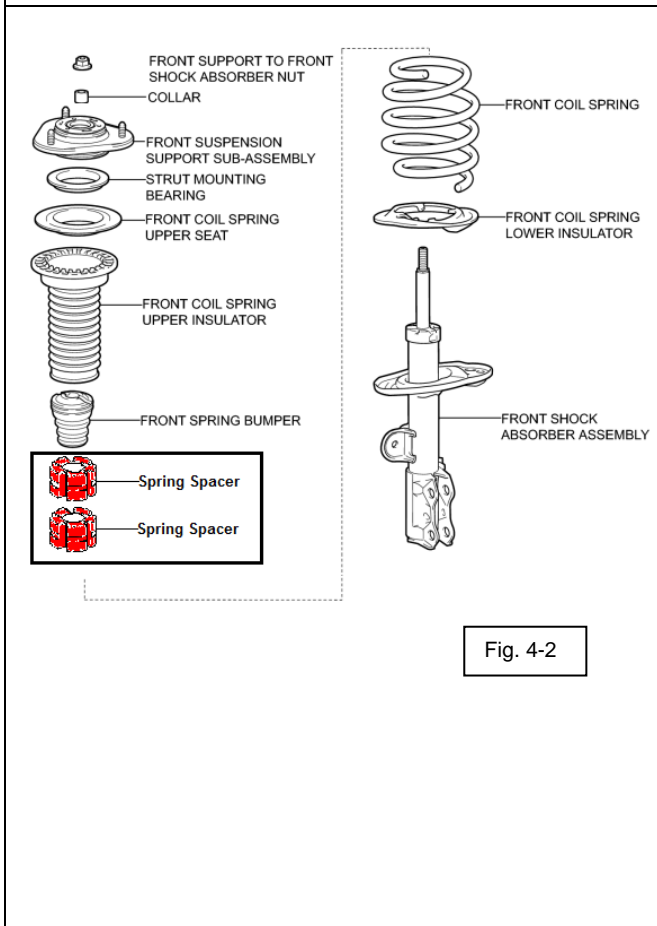

- (b) Install two supplied spring spacers per strut. **(PORT PROCESSING ONLY)**
  - (1) Fasten one nylon tie around each spacer.
  - (2) Cut excess material protruding from nylon tie fastener flush to the surface of the fastener.
- (c) Install front spring bumper. (Fig 4-2)
  - (1) Install the spring bumper onto the coil spring seat upper.
- (d) Install the coil spring seat upper with the strut mount bearing and spring bumper onto the shock absorber.
- (e) Install **new** shock absorber nut.
  - (1) Do not force the nut causing the coil spring seat to rotate.
  - (2) This nut will be torqued down later, once the strut assembly is back on the car.

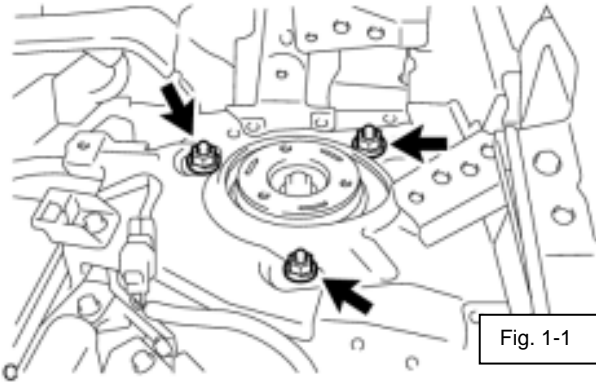

## 5. INSTALL FRONT STRUT ASSEMBLY



(a) Raise strut up into wheel well, fasten 3 nuts.

**Torque: 50 N·m (510 kgf·cm, 37 ft·lbf)**

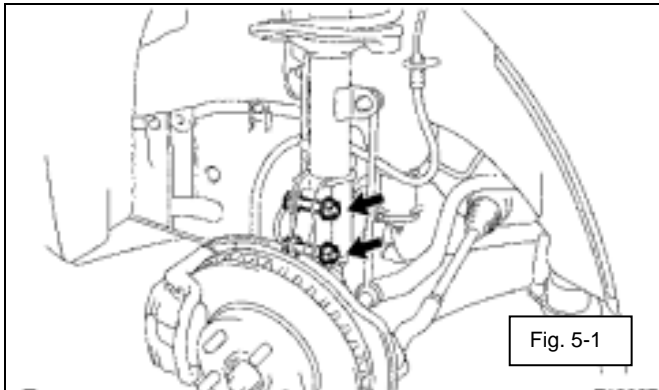

(b) Attach strut assembly to knuckle with 2 bolts and 2 nuts. Install bolts the same way they came off. (Fig. 5-1)

Note: Do not push or pull on strut assembly while tightening nuts, this will maintain factory camber settings.

**Torque: 240 N·m (2447 kgf·cm, 177 ft·lbf)**

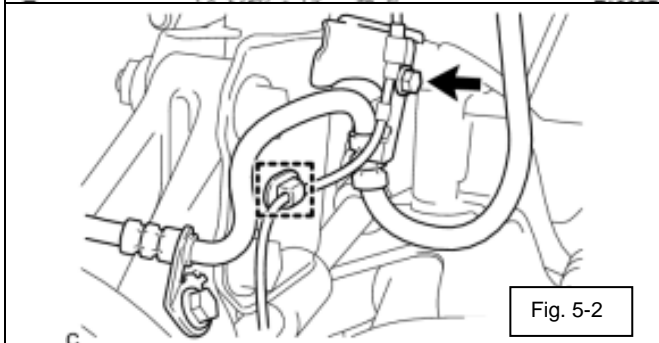

(c) Attach front flexible brake hose and speed sensor if equipped. (Fig. 5-2)

(1) Install the flexible hose and speed sensor without twisting them.

**Torque: 29 N·m (296 kgf·cm, 21 ft·lbf)**

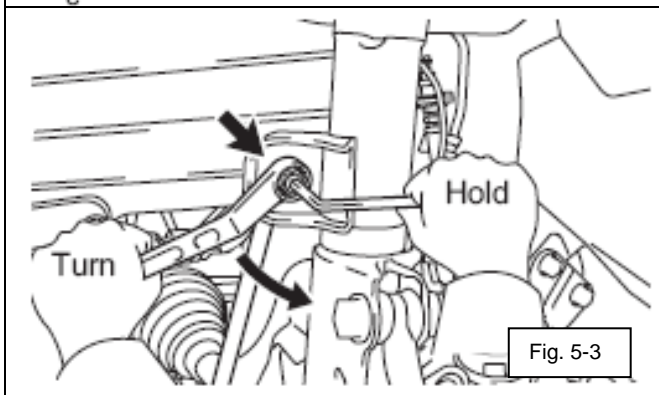

(d) Attach front stabilizer link assembly.

(1) If the ball joint turns together with the nut, use a 6 mm allen wrench to hold the stud. (Fig. 5-3)

**Torque: 74 N·m (755 kgf·cm, 55 ft·lbf)**

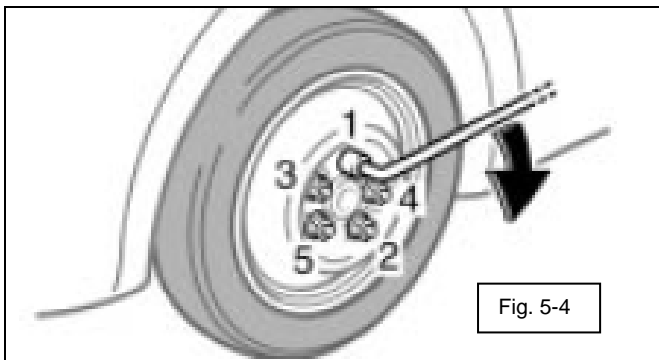

Fig. 5-4

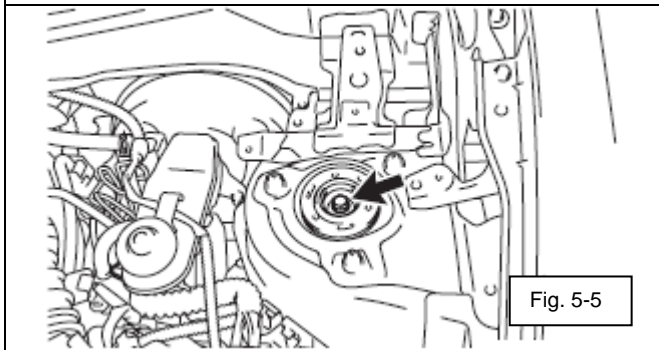

Fig. 5-5

(e) Install front wheel.

(1) Install wheel nuts (tapered side against the wheel.)

(2) Tighten in a star pattern. (Fig. 5-4)

**Torque: 103 N·m (1,050 kgf·cm, 76 ft·lbf)**

(f) Now go back to the upper shock absorber nuts and tighten them. (Fig. 5-5)

**Torque: 47 N·m (479 kgf·cm, 35 ft·lbf)**

(g) Install front suspension support dust cover.

## 6. Remove Rear OE Springs

(a) Disconnect lower shock eye from axle beam.

(1) Support shock mount with a tall jack stand.

(2) Loosen the bolt **NOT** the nut. (Fig. 6-1)

(3) Only work on one side of the vehicle at a time to prevent the axle beam from swinging too low putting unwanted tension on the beam axle bushings.

(b) Remove original spring.

(1) Pull down on beam axle and lift bottom of spring out of the spring seat.

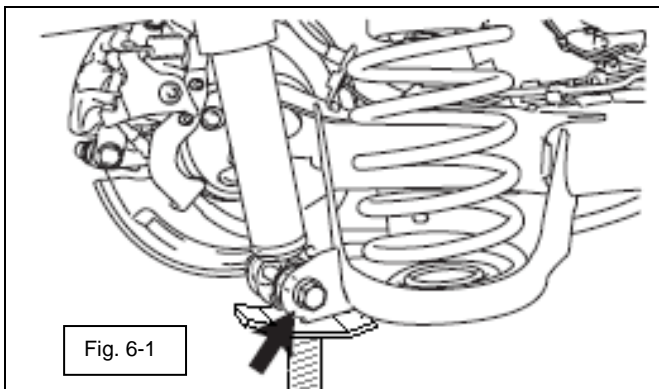

Fig. 6-1

## 7. Install Rear TRD Springs

(a) Install rear spring insulators.

(1) Confirm the coil spring insulator lower is seated properly on the beam axle.

(2) Install the coil spring insulator upper so that its pocket fits onto the end of the coil spring. (Fig 7-1)

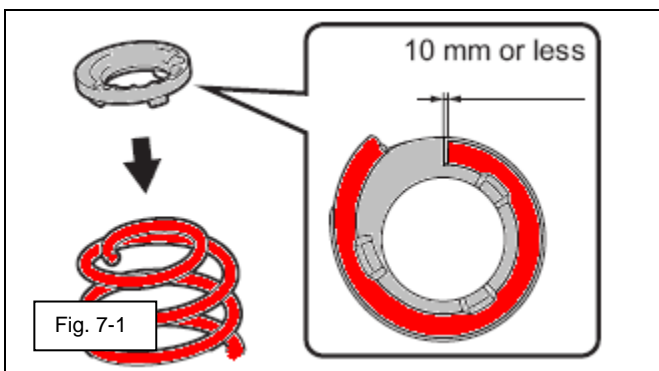
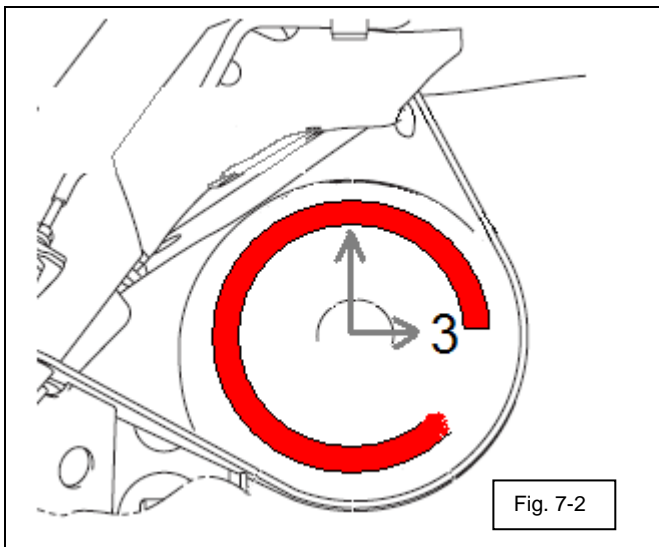

Fig. 7-1





(b) Install coil spring onto axle beam.

- (1) Position the tightly wound coils facing the top of the vehicle.
- (2) Make sure the bottom ends of the springs are indexed the same left and right. This will ensure equal ride height. The lower ends of the springs should be at the 3 o'clock position. (Fig. 7-2)

(c) Reinstall rear shock absorber lower.

**Torque: 90 N·m (918 kgf·cm, 67 ft.·lbf)**

## 8. Install Cowl and Wiper Assembly

(a) Install metal cowl pan.

**Torque: 12 N·m (122 kgf·cm, 9ft·lbf)**

(b) Install wiper motor and link assy.

- (1) Connect wire harness and clip harness to cowl pan.

**Torque: 5.5 N·m (56 kgf·cm, 49 in.·lbf)**

(c) Install cowl top vent louvers (plastic).

(d) Install wiper arms. (Fig 8-2)

**Torque: 26 N·m (265 kgf·cm, 19 ft.·lbf)**

**Hint \*1:** There are clear dots in the black paint at the bottom of the windshield to indicate proper wiper blade location.

(e) Place hang tag on mirror.

Spring spacer removal instructions are to face the windshield.

**(PORT PROCESSING ONLY)**

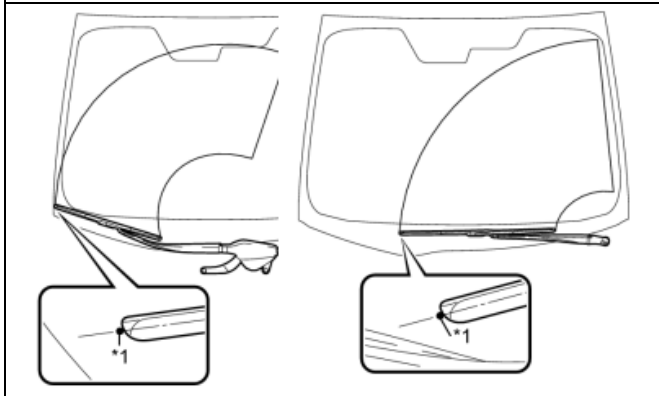
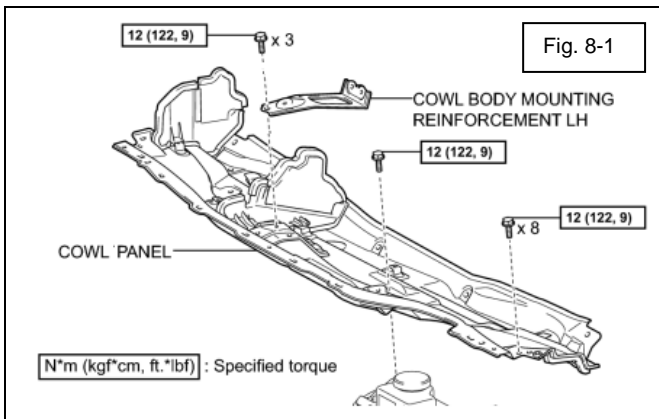



Checklist. These points MUST be checked to ensure a quality installation.

CHECK FOR:

Accessory Function Checks

LOOK FOR:

Vehicle Function Checks

Confirm wipers operate properly

Torque on all fasteners.

- No operation
- Hitting edge of windshield seal

The torque specs. called out in these instructions are taken directly from the 2010 Toyota Prius repair manual. Torque specs. are expected to be accurate within the capability or range of the tool used during assembly (typically +/- 4%).