

NOTE
Static Sensitive Device. ESD precautions apply.

Purpose:

- This document covers the suggested installation instructions for the Timken M15 Modular Encoder. Contact Timken for non-standard installations.

Definitions:

- O/C: Open Collector
- L/D: Line Driver
- C/P: Index Pulse
- COM: Commutation

Reference:

- Timken Modular Encoder Specification Sheet C-74351

Timken Technical Support:

- Email: sensortech@timken.com
- Hotline: 1-603-358-4760
- Website: www.timken.com/motion control

Parts List

Standard Components - See Fig. 1

Description	Qty.
M15 Encoder	1
M15 Encoder Wheel	1
Alignment Tool	1
Air Gap Shim 0.635mm (0.025 in.) for resolution 100-1280	1
Air Gap Shim 0.127mm (0.005 in.) for resolution 2000 & 2048	1

Optional Components - See Fig. 2

Description	Qty.
Allen Wrench – 1.5 mm (0.059 in.)	1
M2.5 X 6 Screw Kit	2
#2-56 X 1/4 Screw Kit	2
Cover With/Without Through-hole	1
Connecting Cable 0.5 m (1.64 ft.)	1

Fig. 1

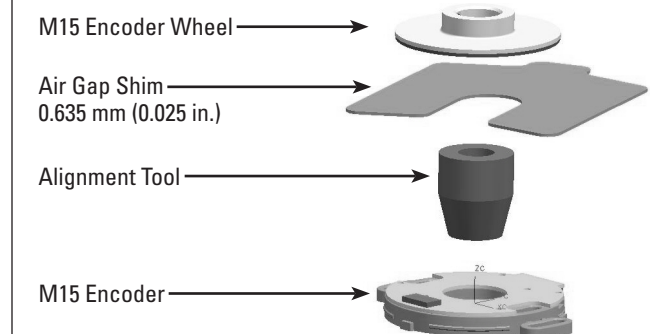
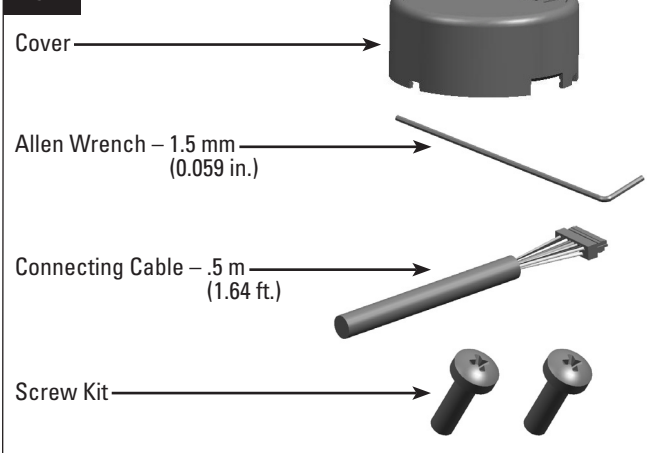

Fig. 2



Part 1: Installation Instructions – Encoder to Motor

1. Make sure the encoder mounting surface is flat and clean.

The Timken M15 Modular Encoder's base allows for some flexibility when mounting to motors with bearing caps and bosses. If the Timken M15 Modular Encoder does not sit flat, the installer must provide a flat surface for proper installation.

2. Using either of the available mounting locations, loosely fasten the M15 Encoder to the motor using Timken-supplied optional hardware or customer-supplied hardware. **DO NOT TIGHTEN!** The use of an anaerobic sealer, like Loctite 222, is suggested for mounting fasteners. See Fig. 3 for mounting locations and dimensions.

The Timken M15 Modular Encoder will accept fasteners up to 2.9 mm (0.114 in.) in diameter with head sizes ranging from 4.5 mm (0.177 in.) to 5.0 mm (0.200 in.) in diameter. A captive washer is suggested.

3. Slide the Alignment Tool down the motor shaft into the Timken M15 Modular Encoder as shown in Fig. 4.
4. Rotate the Timken M15 Modular Encoder as needed, center the encoder by lightly pushing the Alignment Tool into the center hub and tighten mounting screws to a suggested torque of 1.5 kgf-cm (22 ozf-in).

For easy alignment, the Timken M15 Modular Encoder allows for up to ±9° of rotation around its base plane.

5. Remove the Alignment Tool.
6. Position the Air Gap Shim so it is covering the Timken Magnetic Encoder ASIC as shown in Fig. 5.
7. Note the Set Screw location on the M15 Encoder Wheel. Slide the Encoder Wheel down the motor shaft until it is resting on the Air Gap Shim.

NOTE

DO NOT FORCE the M15 Encoder Wheel onto the Air Gap Shim as this could damage the Timken M15 Modular Encoder.

Fig. 3

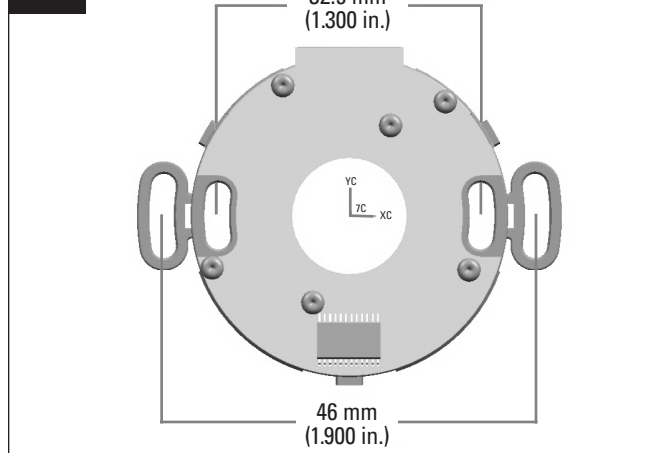

Fig. 4

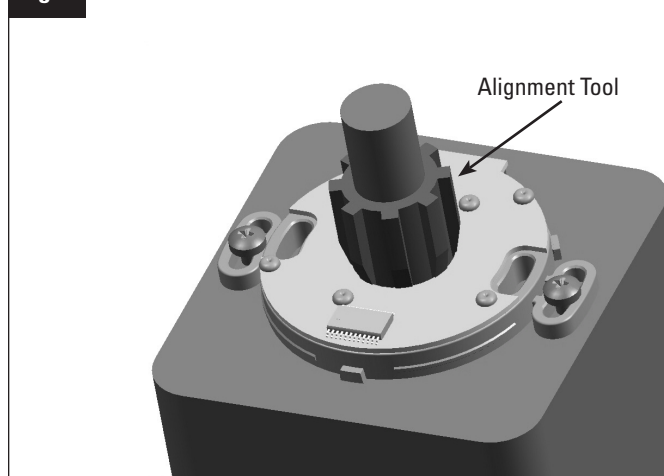

Fig. 5

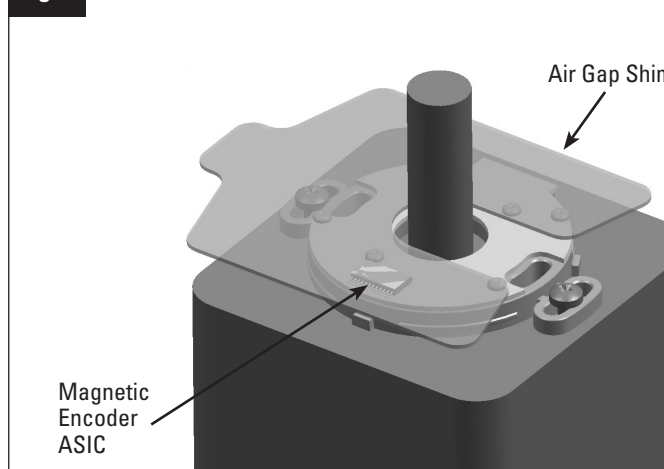
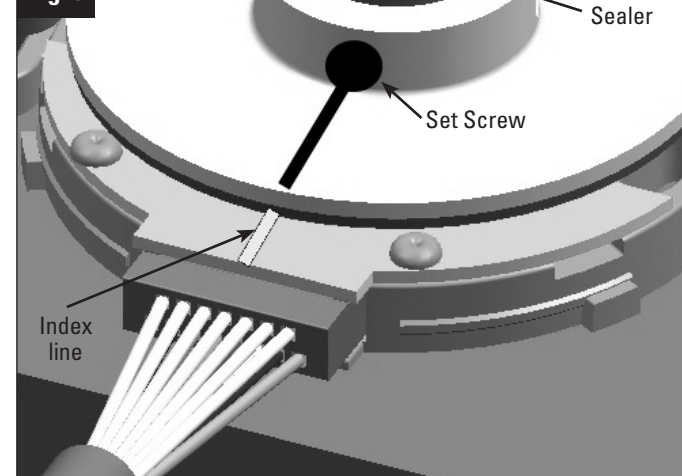

Fig. 6



8. Align the Set Screw of the M15 Encoder Wheel with the Index line on the Timken M15 Modular Encoder as shown in Fig. 6.

The use of an anaerobic sealer is suggested for mounting the M15 Encoder Wheel. Apply a small amount of anaerobic sealer, like Loctite 641, to the gap between the top of the M15 Encoder Wheel and the motor shaft. See Fig. 6.

TIMKEN

Where You Turn

M15 Modular Encoder Assembly Instructions

! WARNING

Failure to observe the following warnings could create a risk of serious injury.

The following step is different from the normal procedure because of the tighter air gap requirements of the 2000 & 2048 line encoder. The following step is meant to eliminate the possibility of the target making contact with the electrical components on the PCB by eliminating the endplay movement towards the PCB.

Fig. 7

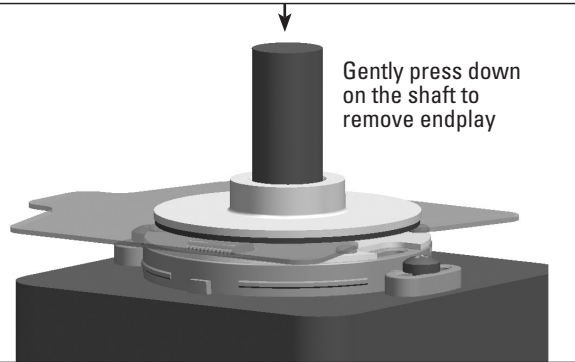

Gently press down on the shaft to remove endplay

- While gently push down on the shaft to seat the shaft as far back into the motor as possible, tighten the M15 Encoder Wheel's set screw to a maximum torque of 3.9 kgf-cm (55-60 ozf-in).
- Tighten the M15 Encoder Wheel's Set Screw to a maximum torque of 3.9 kgf-cm (55 ozf-in).

! CAUTION

Failure to observe the following cautions could create a risk of injury.

Insufficient tightening of the set screws may result in encoder wheel coming off the shaft.

- Gently remove the Air Gap Shim
- Snap the Cover into place aligning the connector relief with the connector on the Timken M15 Modular Encoder. See **Fig. 7**.

The M15 Cover can be ordered with various through-holes allowing the motor shaft to protrude.

Part 2: Installation Instructions – Electrical Connections

NOTE

System power must be OFF before making any electrical connections. Refer to all applicable NEC regulations.

- Connect the optional M15 Connecting Cable to customer-supplied motor controller and feedback systems using the suggested terminations in **Table 1**.

NOTE

Timken suggests that the installer should attach the cable shield to electrical ground. Unused encoder signal wires must be individually insulated and under no circumstances in contact with grounding voltage sources or other signal lines.

- Attach the optional M15 Connecting Cable to the Timken M15 Modular Encoder as shown in **Fig. 8**. Refer to Timken Document Number C-75641 for cable diagram, available at www.timken.com/motion control
- Timken suggests anchoring the M15 Connecting Cable no more than 152.4mm (6.0 in.) from the Timken M15 Modular Encoder.

Fig. 8

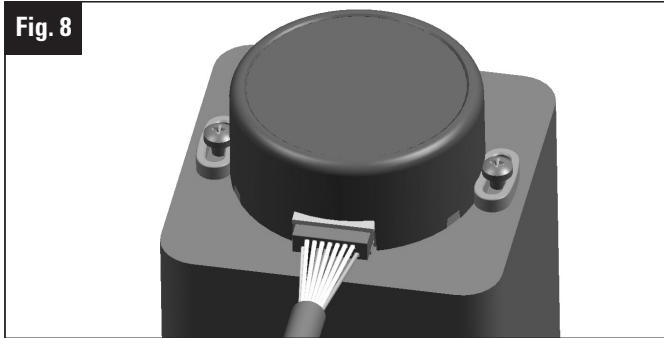

Part 3: M15 Modular Encoder Technical Specifications

- Scope - M15 Specifications and Requirements
- Mechanical Specifications
 - See **Fig. 9**
 - Mounting Requirements see **Fig. 9**
 - Mounting Screw (Thread Locker Suggested)
 - M2.5 Mounting Screw Torque 18-20 ozf-in
 - M3 Set Screw Torque 55-60 ozf-in
 - #2-56 Mounting Screw Torque 18-20 ozf-in
 - Termination, see **Table 1**
 - Hub Bore Sizing, see **Table 2**
 - Allowable Shaft End Play $\pm .010$ in (.254 mm)
 - Shipping Weight 1.0 ozs (28 g)
 - Hub Material: Steel with Flash Nickel, (ROHS Compliant)
 - Magnet Material: Nitrile Bonded Ferrite
 - Moment of Inertia see **Table 2**
 - Vibration Specification: 3G 20-2000 Hz
 - Rotational Adjustment of Alignment: $\pm 8^\circ$
- Electrical Specifications
 - Code: Incremental with Commutation and once around Index Pulse Marker
 - Counts Per Revolution see **Table 3**
 - Supply Voltage
 - Single 5.0V ± 0.25 V
 - Current see **Table 1**
 - Output Formats: see **Fig. 9**
 - Output Format: Logic Levels:
 - Logic "1" 2.5 VDC Min.
 - Logic "0" 0.5 VDC Max.
 - Output Type:
 - Line Driver: 20mA Sink/Source
 - Open Collector 10mA Sink Max
 - Output Format Commutation: see **Fig. 9**
 - 1/2 = 4 Pole Motor = 2 Commutation Cycles/360°
 - 2/3 = 6 Pole Motor = 3 Commutation Cycles/360°
 - 3/4 = 8 Pole Motor = 4 Commutation Cycles/360°
 - 4/6 = 12 Pole Motor = 6 Commutation Cycles/360°
 - Operating RPM
 - 10,000 RPM MAX
- Environment Specifications
 - Operation Temperature
 - 40° C - 85° C
 - Storage Temperature
 - 55° C - 125° C
 - Humidity: 85% Relative (Non-Condensing)
 - IP Rating: IP40 with Cover

Fig. 9

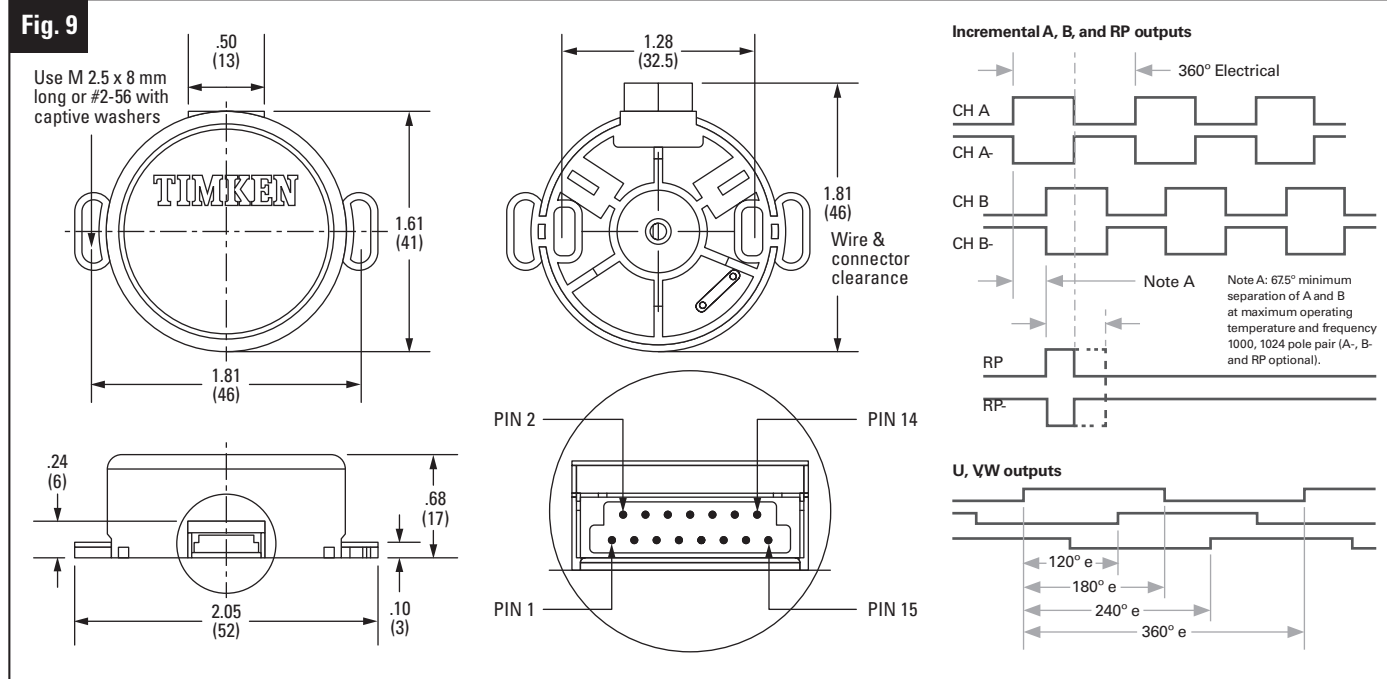

Table 1 - Cable/Pin Functions

Pin #	Function	Color	A,B, Index, O/C	A,B, Index, L/D	A,B, Index, C/P,O/C	A,B, Index, C/P,L/D,COM
Pin 1	A+	YEL	A+	A+	A+	A+
Pin 2	A-	YEL/WHT		A-		A-
Pin 3	B+	BLU	B+	B+	B+	B+
Pin 4	B-	BLU/WHT		B-		B-
Pin 5	Index+	ORN	Index+	Index+	Index+	Index+
Pin 6	Index-	ORN/WHT		Index-		Index-
Pin 7	U+	GRN			U+	U+
Pin 8	U-	GRN/WHT				U-
Pin 9	V+	BRN			V+	V+
Pin 10	V-	BRN/WHT				V-
Pin 11	W+	WHT			W+	W+
Pin 12	W-	WHT/GRY				W-
Pin 13	+5V	RED	+5V	+5V	+5V	+5V
Pin 14	Ground	BLK	Ground	Ground	Ground	Ground
Current (mA)			39	65	63	105

Table 2

Hub Size	Hub ID Tolerance	Shaft Size with Tolerance	Moment of Inertia oz - in sec ²
1/8	0.1250 / 0.1256	0.1250 / 0.1245	0.1173
3/16	0.1875 / 0.1881	0.1875 / 0.1870	0.1183
5mm	0.1968 / 0.1974	0.1968 / 0.1963	0.1185
6mm	0.2362 / 0.2368	0.2362 / 0.2357	0.1194
1/4	0.2500 / 0.2506	0.2500 / 0.2495	0.1197
5/16	0.3125 / 0.3131	0.3125 / 0.3120	0.1216
8mm	0.3149 / 0.3155	0.3149 / 0.3144	0.1217
3/8	0.3750 / 0.3776	0.3750 / 0.3654	0.1248
*10mm	0.3937 / 0.3943	0.3937 / 0.3932	0.1339
* 1/2	0.5000/0.5006	0.5000/0.4995	0.1742

* Special order option

Table 3

RESOLUTION lines/ch	
100	500
125	512
128	640
160	800
200	1000
250	1024
256	1280
320	2000
400	2048

TIMKEN
Where You Turn

www.timken.com

Timken® is a registered trademark of The Timken Company

© 2009 The Timken Company
Printed in U.S.A.
5M 08-09-29 Project No. 0324

Every reasonable effort has been made to ensure the accuracy of the information contained in this writing, but no liability is accepted for errors, omissions or for any other reason.