

# MPC023/034 Spring Applied Brake



## General Information

- Insulation Class B
- Zinc plating housing
- Long life
- Special application on request

## Mechanical

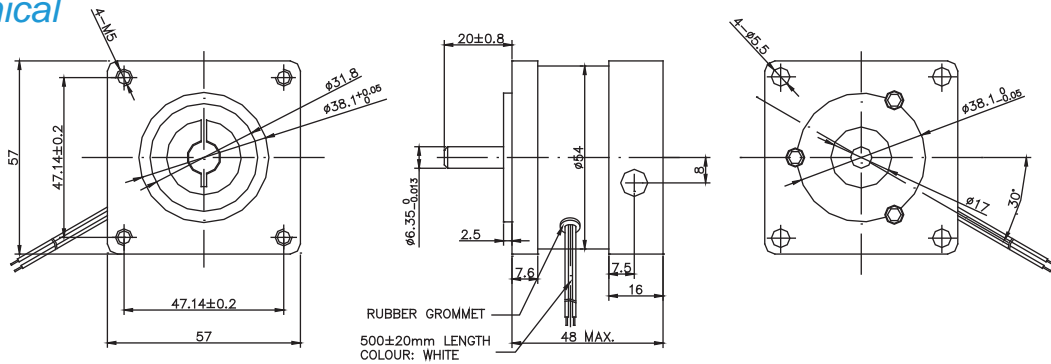

**MPC023-**

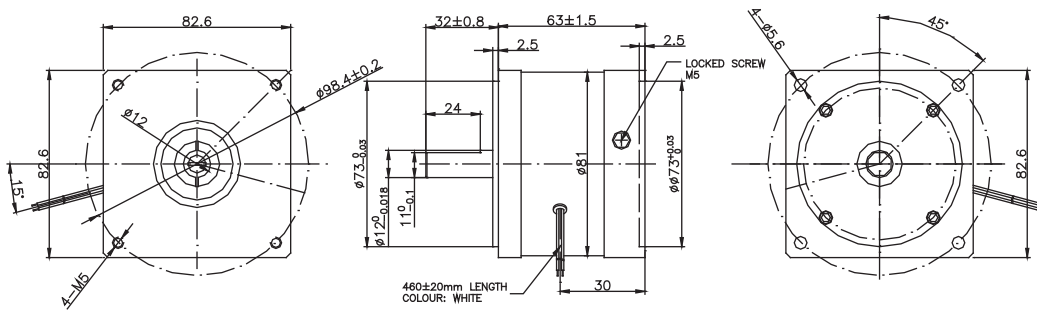

**MPC034-**

## Specifications

| Model   | Voltage<br>(VDC) | Resistance<br>(OHMS) | Current<br>(A) | Static Torque<br>(Nm) | Power<br>(w) | Weight<br>(g) |
|---------|------------------|----------------------|----------------|-----------------------|--------------|---------------|
| MPC023- | 24               | 88                   | 0.27           | 0.34                  | 6.4          | 400           |
| MPC034- | 24               | 96                   | 0.25           | 1.68                  | 6            | 500           |

## Implication For Name

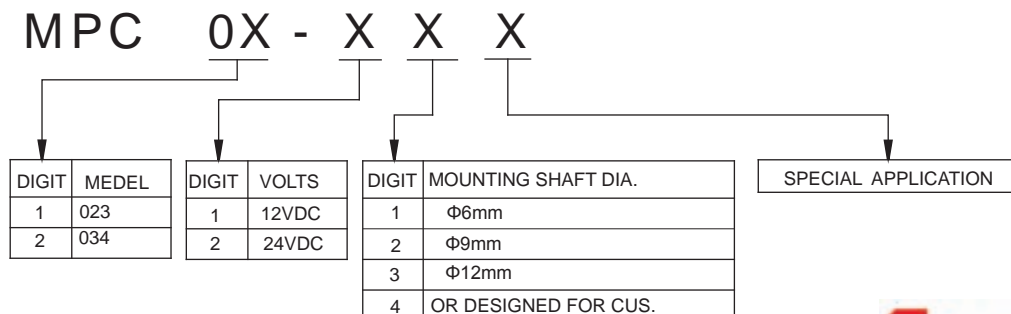

BRAKE