

REVAL

SUSTAINABLE WELL-BEING

New



Powered
5605.00UK

Soflex Hygiene Chair

Ref: Manual 5601.00UK / Powered 5605.00UK

*Transport, toilet, shower
and posture management
in one product*

The **Soflex** Hygiene Chair is a highly versatile and height adjustable commode and shower chair that makes hygiene procedures safe and comfortable for both patients and caregivers. Its integrated tilt system assists posture management during patient transfers and its high-low function, available as a manual or powered version, allows easy access for routines such as toileting, showering and hair washing.

Three year
warranty

Unique features

- ▶ Powered posture management is safe and effortless
- ▶ Powered seat height adjustment
- ▶ Powered 'tilt-in-space' adjustment
- ▶ Padded commode seat and backrest cushion for comfort.
- ▶ Wrap-around armrest for added security and posture control
- ▶ Flip-up removable footrests to aid standing transfers
- ▶ Adjustable length leg rests for comfort and safety
- ▶ Available with commode pan option
- ▶ Saves space and reduces equipment required with its multi-functional capabilities
- ▶ Safe working load of 135kg



Padded seat back and
armrests for added comfort



Soflex with commode
pan option

New

Soflex Hygiene Chair

Ref: Manual 5601.00UK / Powered 5605.00UK



Manual
5601.00UK



Waterproof control box with
emergency stop button



Powered tilt-in-space and
seat height adjustment

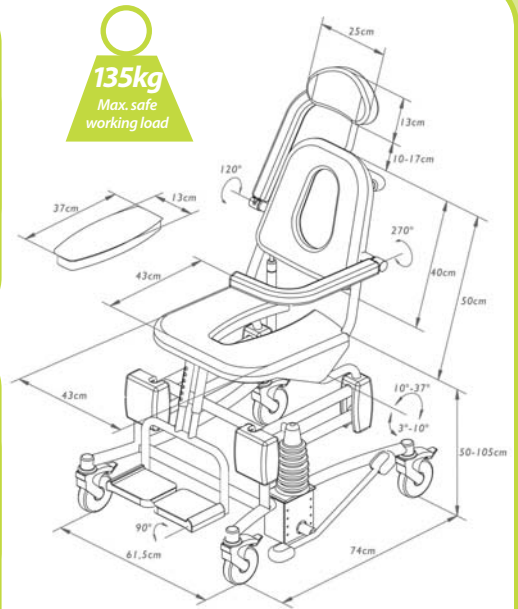

Dimensions for both manual and powered chairs

Technical Specifications

General

- ▶ Tubular frame, anti-corrosion coated
- ▶ Mechanical parts and hinges in stainless steel
- ▶ Four castors Ø 125mm with brakes
- ▶ Steering handle
- ▶ Seat, backrest, armrests, head support and footrests in polyurethane
- ▶ Folding armrests with safety locks
- ▶ Folding footrests and a detachable headrest are all height adjustable
- ▶ Optional commode pan with guide rail (ref: 5601.00)

Performance

- ▶ Maximum patient weight: 135kg
- ▶ Weight of the chair (manual): 35kg
- ▶ Weight of the chair (powered): 39kg
- ▶ Minimal height of the seat: 50cm
- ▶ Lifting range: 55cm
- ▶ Tilt range for seat: 3-10° - 10-37°
- ▶ Head support adjustable by: 7cm
- ▶ Footrests adjustable by: 8cm

Manual model (ref: 5601.00)

- ▶ Adjustable in height by hydraulic pump and pedal
- ▶ Gas jack assisted backrest to recline with ease

Powered model (ref: 5605.00)

- ▶ Adjustable tilt-in-space and seat height adjustment
- ▶ Four functions hand control
- ▶ Waterproof control box
- ▶ Actions via X2 / 24Vdc powered actuators
- ▶ Emergency stop and lowering buttons

Safety standards

- ▶ Qualified 93/42 CE directive (medical equipment)
- ▶ NF EN ISO 10535 (person lifts)
- ▶ NF EN 1441 (risk analysis for medical equipment)

To order or enquire about Soflex,
please use the contact details below:

DEALER STAMP