

WILDFIRE

1/10 4WD ELECTRIC COMPETITION TOURING CAR KIT



DRIVER Dave Johnson DATE 14 Mar 2013
 TRACK NAME Seaway Mall, Welland, ON, Canada RESULT _____
 TRACK SURFACE Carpet GRIP CONDITION HI MED LOW _____
 HUMIDITY _____ TRACK TEMP 24C

SETUP SHEET

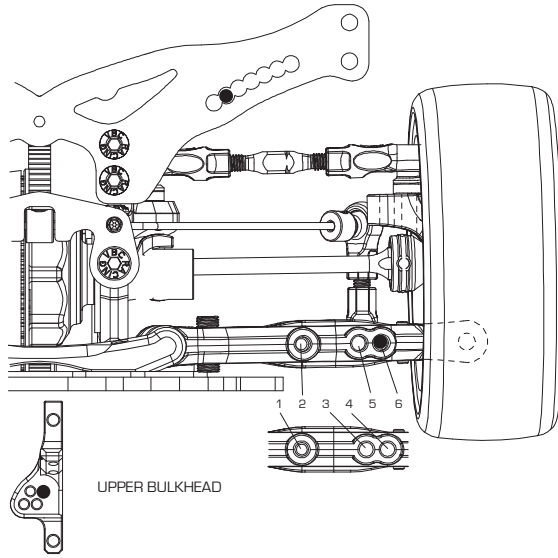
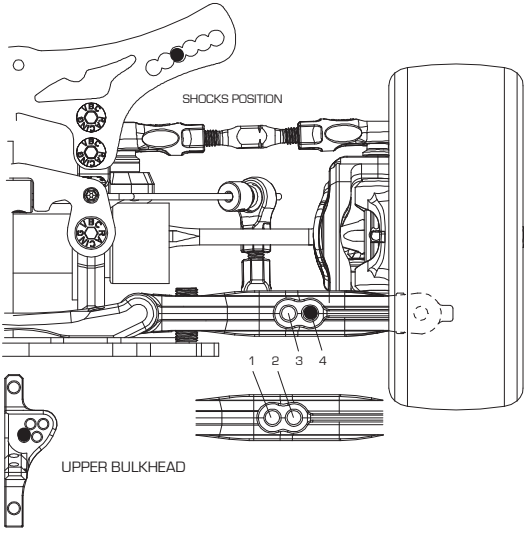

FRONT

GROUND CLEARANCE 5 mm REBOUND 25%

CAMBER ANGLE -1.5 ° TOE ANGLE 0 °

CASTER BLOCK 4 ° FRONT DRIVE DIFF (OIL) DIREC

STABILIZER 1.2 1.3 1.4 WHEEL SPACER 0 mm

FRONT SUSPENSION MOUNT SHIM 4 mm REAR SUSPENSION MOUNT SHIM 0 mm

FRONT SUSPENSION MOUNT E30 REAR SUSPENSION MOUNT C0

DOWNSTOP 5 mm

REAR

GROUND CLEARANCE 5 mm REBOUND 25%

CAMBER ANGLE -2.5 ° TOE ANGLE +2.0 °

REAR DRIVE DIFF (OIL) 5000cst

STABILIZER 1.2 1.3 1.4 WHEEL SPACER 0 mm

FRONT SUSPENSION MOUNT SHIM 4 mm REAR SUSPENSION MOUNT SHIM 0 mm

FRONT SUSPENSION MOUNT C0 REAR SUSPENSION MOUNT E20

DOWNSTOP 2 mm

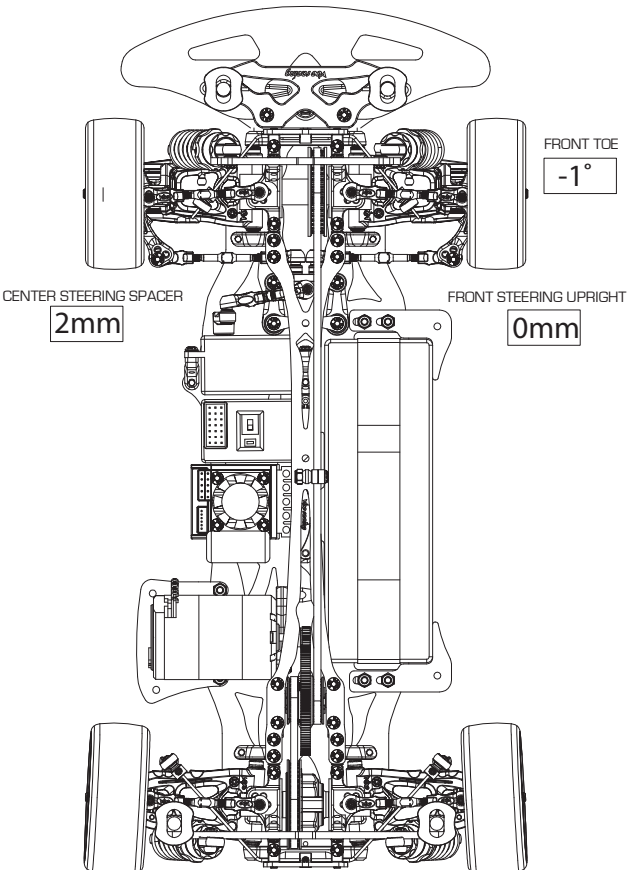

FRONT

SHOCK LENGTH 64.5mm

PISTON 1 2 3 hole(s)

OIL 500cst

SPRING VBC Orange



REAR

SHOCK LENGTH 64.5mm

PISTON 1 2 3 hole(s)

OIL 500cst

SPRING VBC Green

MOTOR 17.5T/4.5T SPUR 96T/116T-64P PINION 51T/29T-64P

TIRE Ride 26006 TIRE INSERT _____ WHEEL _____

TIRE ADDITIVE LRP BODY Speed6 BATTERY _____

REMARKS Canadian Onroad Nats - 17.5 TQ & Winner

Canadian Onroad Nats - Modified A3