

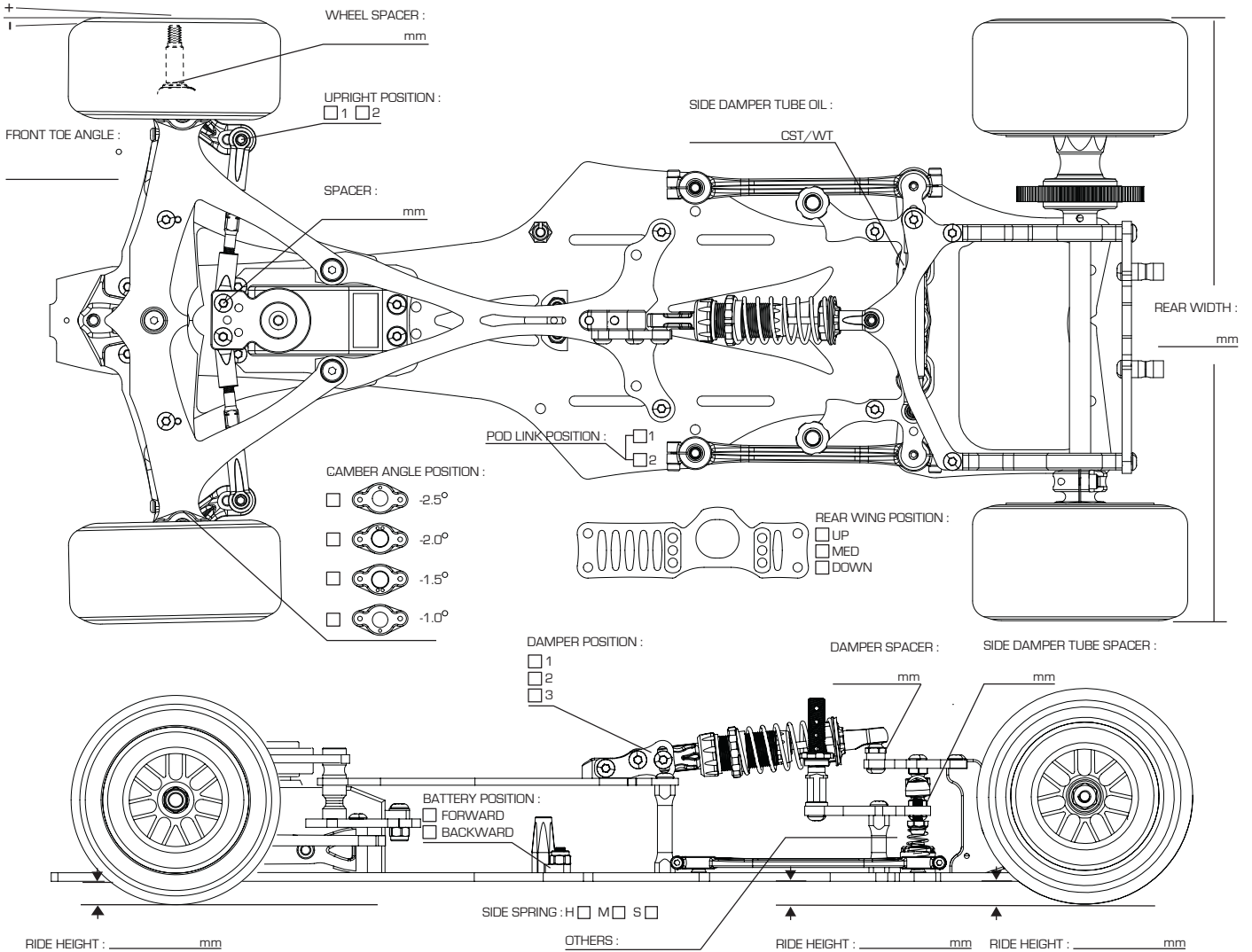

**SETUP SHEET**

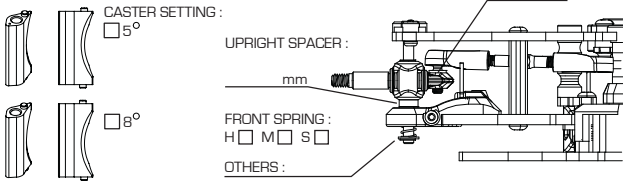

**FRONT**



**TBX SHOCK**



SHOCK LENGTH: \_\_\_\_\_ mm

PISTON: 2  3  HOLE(S) / OTHERS \_\_\_\_\_

OIL: \_\_\_\_\_ CST/WT

SPRING: H  M  S  / OTHERS \_\_\_\_\_

REBOUND: \_\_\_\_\_ %

**REAR AXLE**

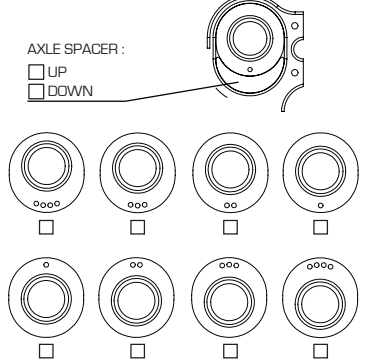

**FRONT TIRES**

TIRE: \_\_\_\_\_

DIAMETER: \_\_\_\_\_ mm

WHEEL: \_\_\_\_\_

TIRE TREATMENT: \_\_\_\_\_

TREATMENT TIME: \_\_\_\_\_

SURFACE TREATED: \_\_\_\_\_

NOTES: \_\_\_\_\_

**REAR TIRES**

TIRE: \_\_\_\_\_

DIAMETER: \_\_\_\_\_ mm

WHEEL: \_\_\_\_\_

TIRE TREATMENT: \_\_\_\_\_

TREATMENT TIME: \_\_\_\_\_

SURFACE TREATED: \_\_\_\_\_

NOTES: \_\_\_\_\_

MOTOR: \_\_\_\_\_ ROTOR: \_\_\_\_\_ TIMING: \_\_\_\_\_

SPUR: \_\_\_\_\_ PITCH/ \_\_\_\_\_ T PINION: \_\_\_\_\_ PITCH/ \_\_\_\_\_ T ROLLOUT: \_\_\_\_\_

ESC: \_\_\_\_\_ SETUP: \_\_\_\_\_ BATTERY: \_\_\_\_\_

STEERING EXPO: \_\_\_\_\_ BRAKE E.P.: \_\_\_\_\_ THROTTLE EXPO: \_\_\_\_\_

BODY: \_\_\_\_\_ WEIGHT: \_\_\_\_\_

REMARKS: \_\_\_\_\_