



Several big pieces of news in this newsletter!

### **1) Resin scenery range price revision!**

After taking in feedback from the release of our resin scenery and through looking at the way our customers would prefer to dip into this part of our product line, we've decided to change the pricing structure of the entire range.

Primarily, the goal has been to reduce the cost of getting into the resin scenery range when purchasing smaller amounts, making it easier to build up a collection over time rather than buying in bulk. To this end, we've discontinued all three of our large scenery package deals (Town, City and Metropolis packs), and passed the discount they had incorporated down through the entire range. Coupled with additional efficiencies on the manufacturing side, we've been able to reduce the price of the whole line by a solid 30%! This price reduction is effective immediately and can be seen from today in [the scenery section of our website](#).

### **2) New releases for all four races - some early sneak peeks!**

We've been working on a new unit for each of our four races and we think that now is the time to share a few sneak peeks!

The models are in pre-production at the moment and as such we have a few screenshots to share with you before we get resin to capture. We don't generally approve of screenshots and the like as we prefer to show real, physical products; however, we just couldn't resist showing you a few snippets of what we've been working on! We look forward to reading all your thoughts and debate [on the forum](#) about these new beasts, so without further ado, enjoy!

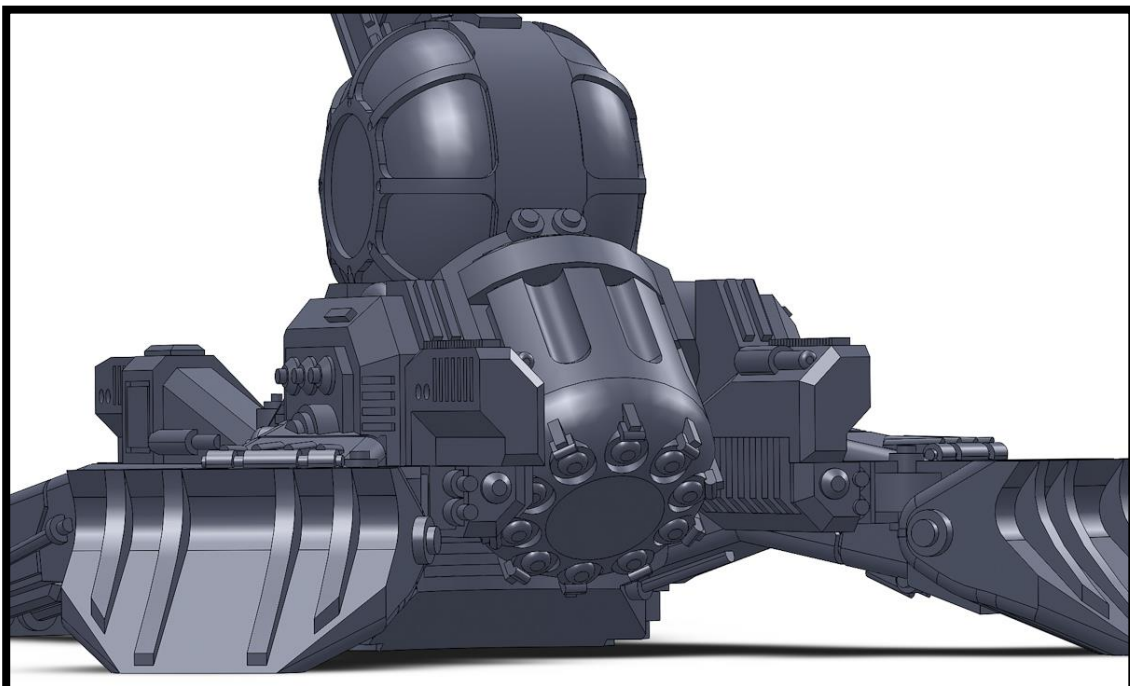

*The fresh UCM unit - no clues for this one!*

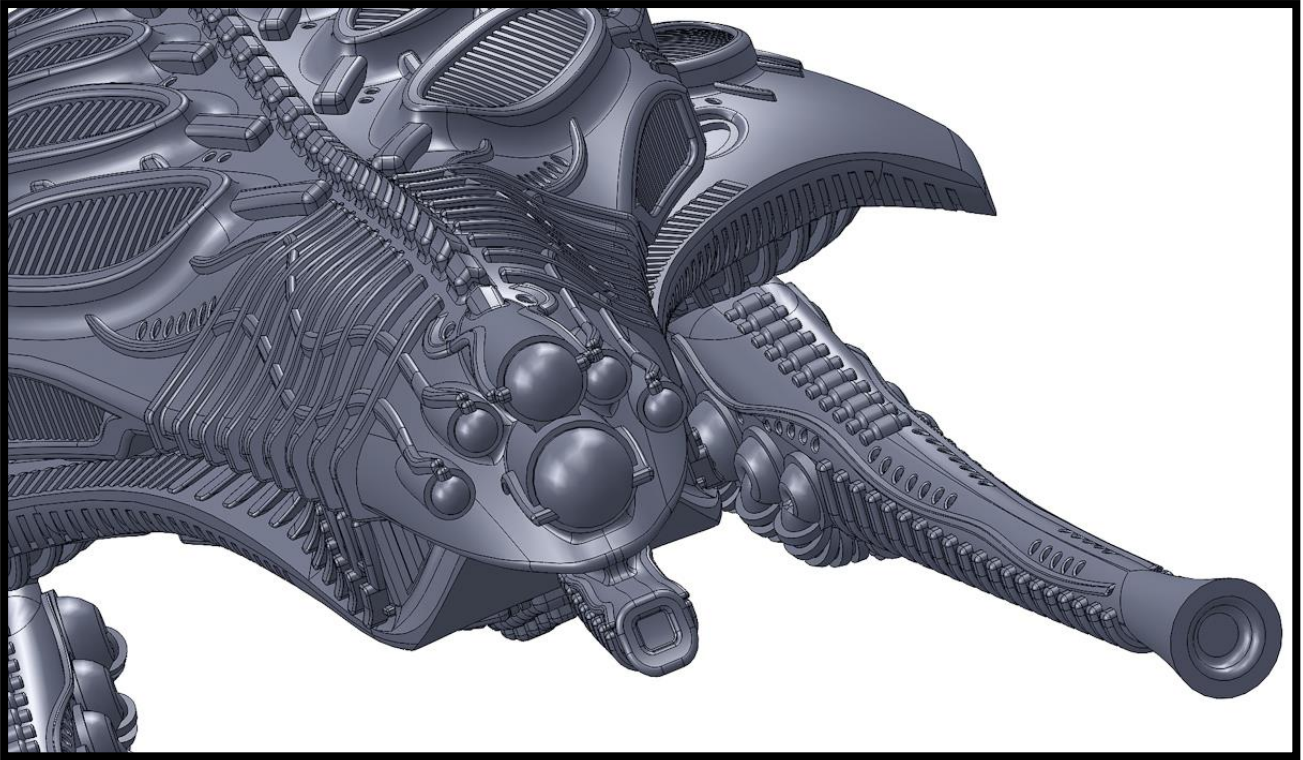

*A new Scourge aircraft - armed and dangerous!*

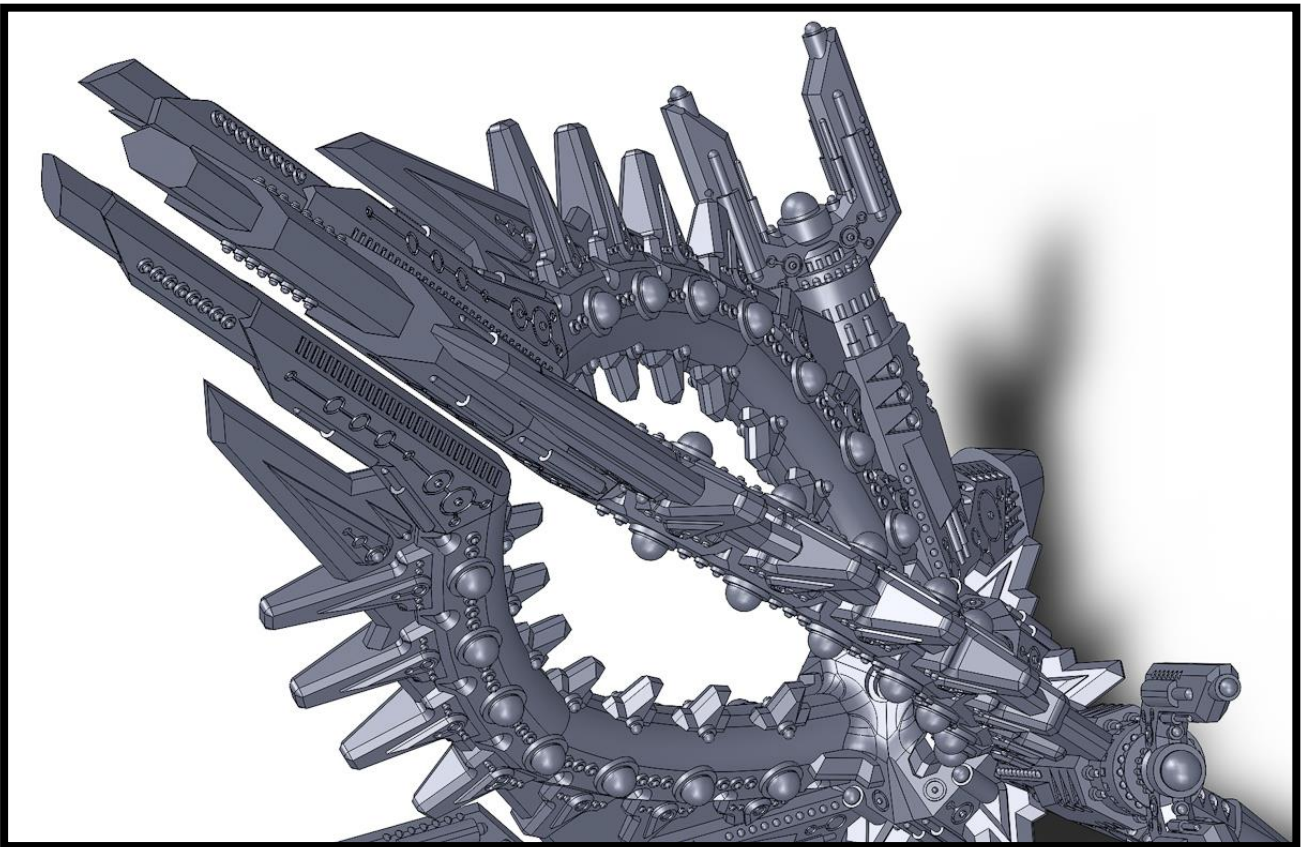

*A looming Shaltari construct - let the speculation begin!*



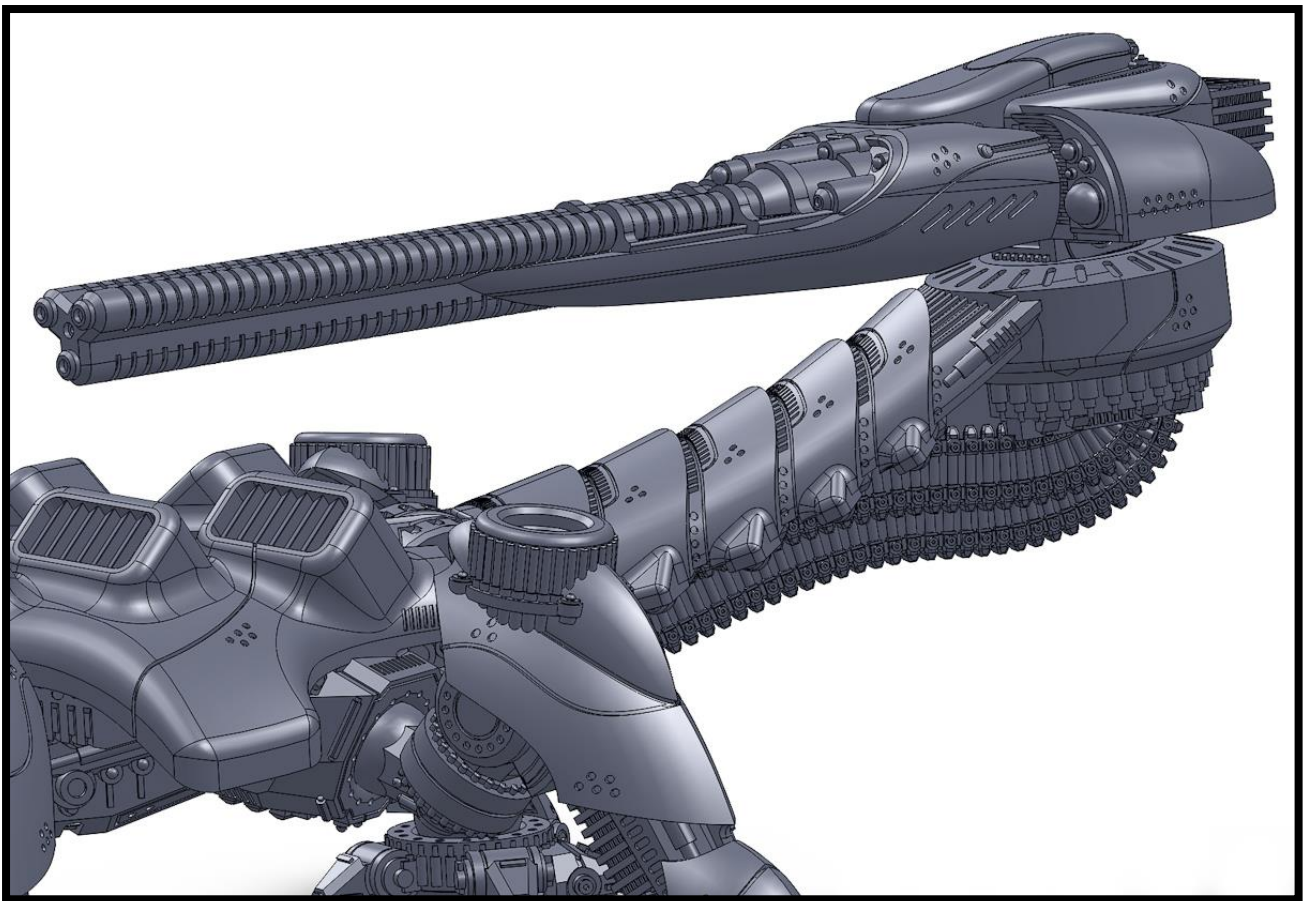

*This time the PHR get something BIG (cue maniacal laughter!)*

We've been working hard to ensure that each of these creations will bring something new to the game for every race and open up some fresh alternative tactics! We'll have our first resin models for these in the next few weeks - keep an eye out for our next newsletter for full release details and complete images of these new units!

Lastly, work continues apace on the Monorail Scenario Pack set. This will feature a full colour box and as such will take us a little while longer to finalise. Full details will emerge shortly about this great new product!

### **3) Hawk Wargames at trade shows**

We've also been busy in the last few weeks travelling up and down the UK for various trade shows. Highlights for us include the vibrant and busy show 'Carronade' in Scotland as well as the 'UK Games Expo' in Birmingham and 'Sheffield Triples', which were great successes for us and introduced many new players to Dropzone Commander!

Although it's still a little while off, we're already preparing for our biggest show of the year, Gen Con Indianapolis 2013! Watch this space for more info.

Stay tuned for more in our next newsletter, which will contain full details of these new releases and more information about Gen Con Indy!

- David J Lewis,

Director,

Hawk Wargames

