

Geoprobe® Model 54LT LIMITED ACCESS

Model 54LT Specifications

Stroke.....	54 in.....	1372 mm
Weight	2,715 lb.....	1232 kg
Width.....	34.5 in.....	876 mm
Length (folded).....	87 in.....	2210 mm
Height (folded).....	64 in.....	1626 mm
Height (unfolded).....	123 in.....	3124 mm
Lateral Movement (side-to-side).....	9 in.....	229 mm
Foot Travel.....	14 in.....	356 mm
Probe Cylinder Diameter.....	4.0 in.....	102 mm
Down Force.....	20,000 lb.....	89 kN
Retraction Force.....	27,000 lb.....	120 kN
Hydraulic Pressure (max.).....	2,200 psi.....	152 bar
Hydraulic Flow Rate.....	10 gpm.....	38 L/min
Hammer System.....		GH42
Percussion Rate.....		30 Hz
Torque.....	620 ft. lbs.....	841 N·M
Rotation Rate (bi-directional).....		80 rpm
Fuel Capacity (diesel).....	8 gal.....	30 liter
Engine Power.....	22 hp.....	16 kw
Engine (diesel).....		Kubota, 3-cylinder
Cooling System.....		Liquid
Outtrigger Travel.....	12 in.....	305 mm

Probe Features

- Hydraulic lateral swing for easy offset placement of probe
- Rod Grip Pull Block ... standard equipment
- Two-speed pull cylinder standard equipment
- Wire remote for ease of maneuverability
- Geoprobe® Limited Access
- Optional Telescopic Cylinder (8ft clearance running 48 in. tooling)
- Auxiliary hydraulic ports provide power supply for remote equipment
- Emergency stop systems for safety of operation
- Rear Stabilizer

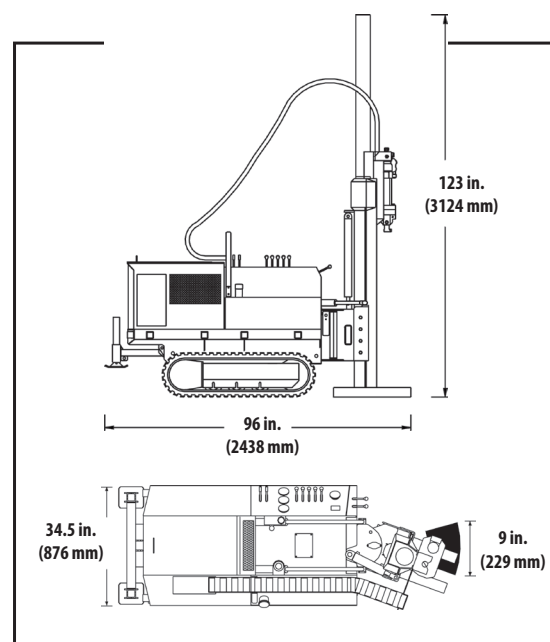

Tooling Options:

- 2.25 in. Probe Rod System
- 1.50 in. Probe Rod Systems
- 1.25 in. Probe Rod System
- MCS Soil Sampling System
- LB Discrete Soil Sampling System
- SP16 Groundwater Sampling System
- PRT Vapor Sampling System

