

Illustrations are for identification purpose only. The right of modification in construction, design or model application is reserved.
Even if shown in the drawing, accessories such as clips, springs, rivets, wear indicators, damping shims etc. are generally not part of PAGID RS pads.

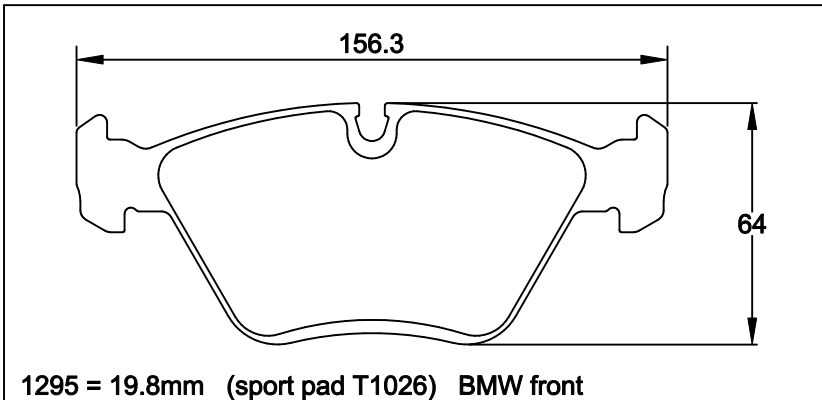

1361
see
1270

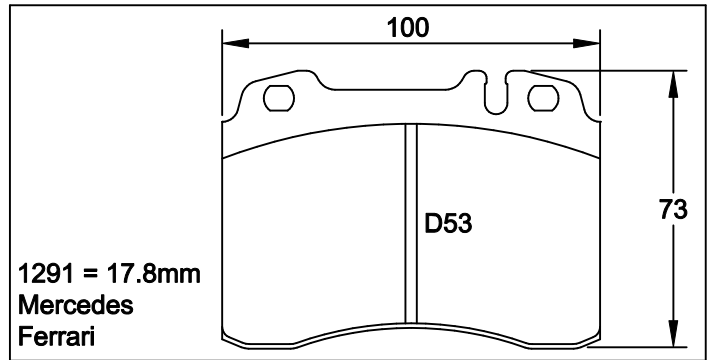
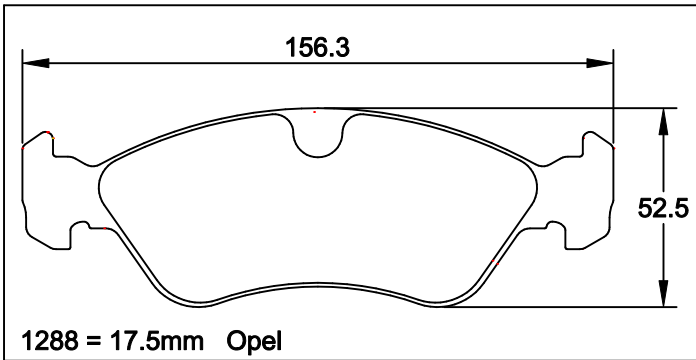
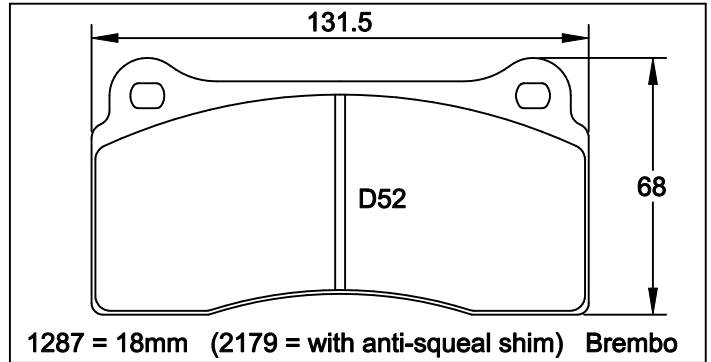
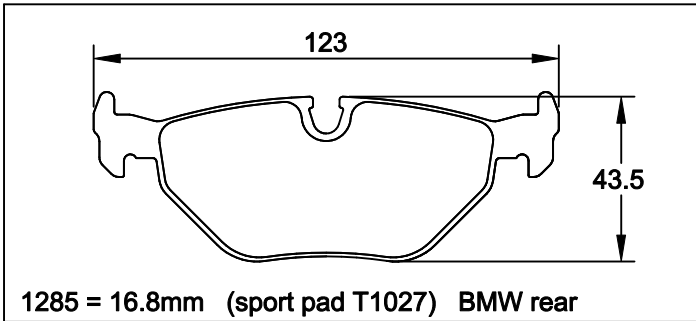
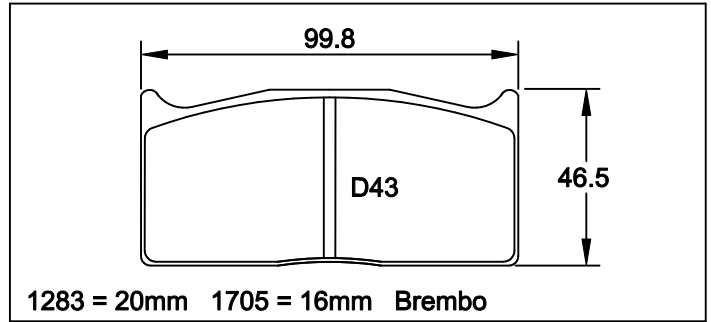
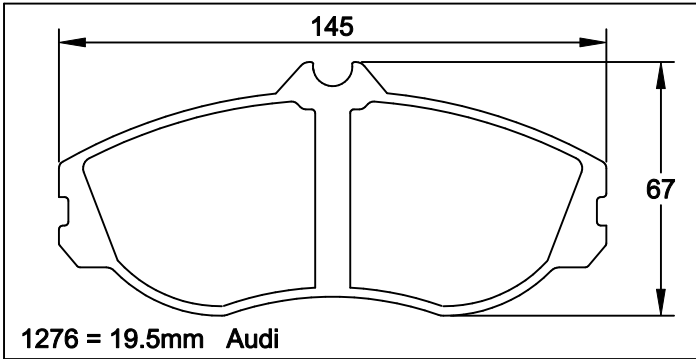
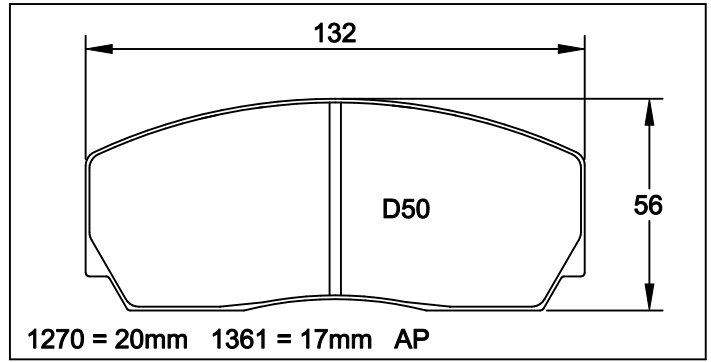
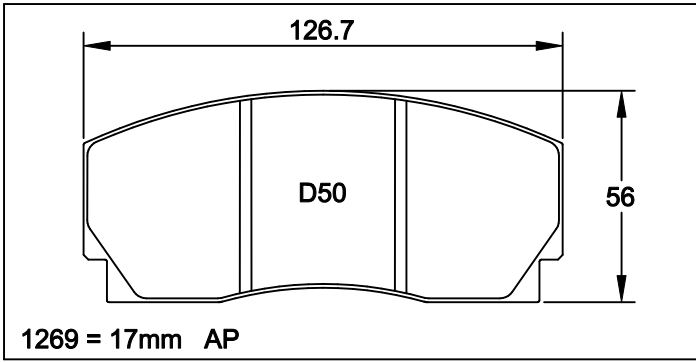
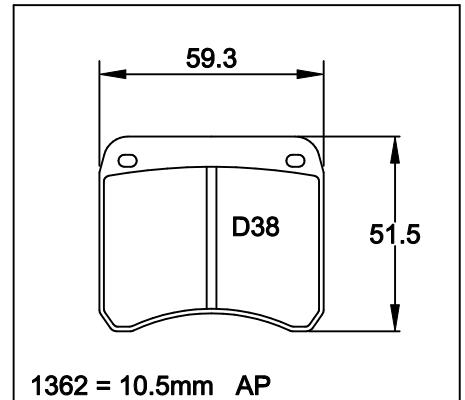

Illustrations are for identification purpose only. The right of modification in construction, design or model application is reserved.
Even if shown in the drawing, accessories such as clips, springs, rivets, wear indicators, damping shims etc. are generally not part of PAGID RS pads.

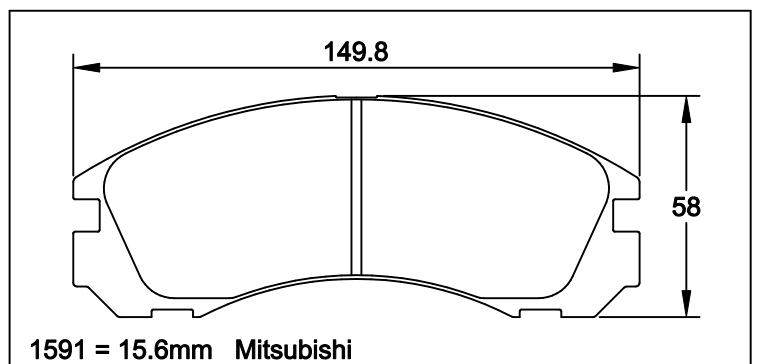
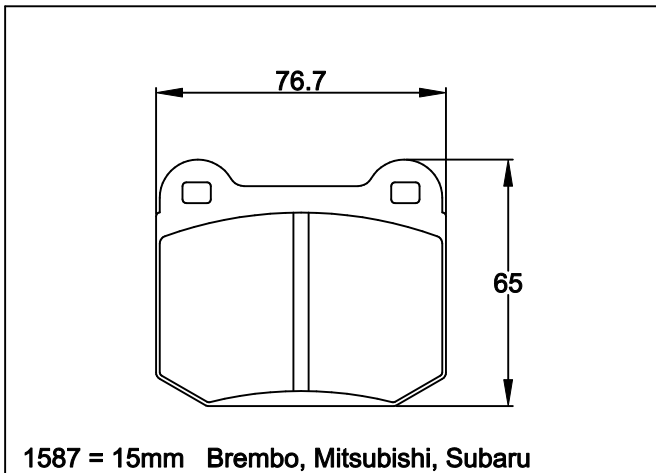
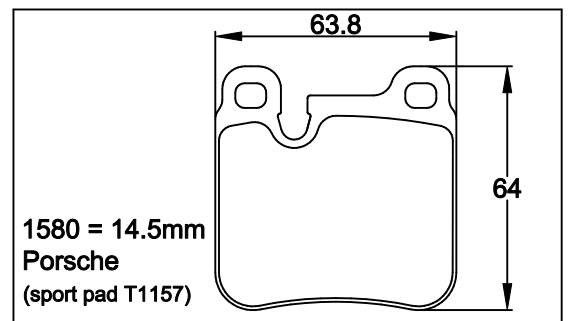
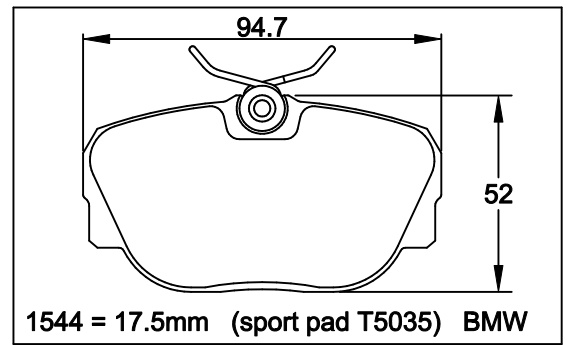
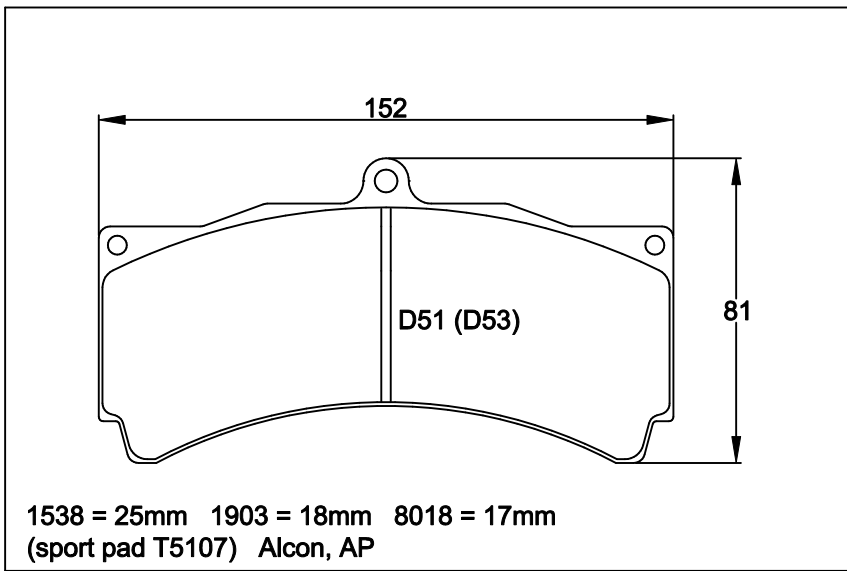
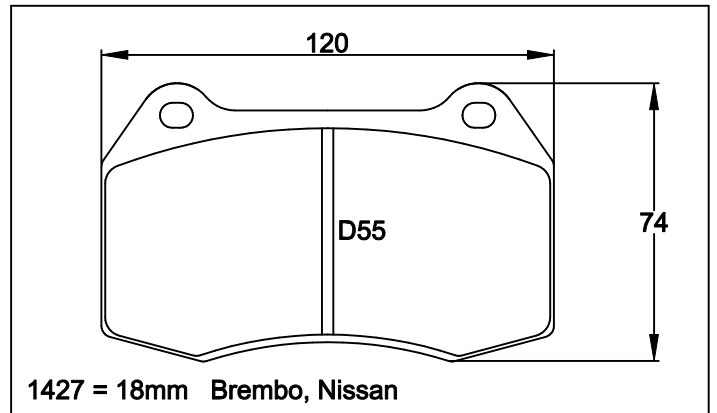
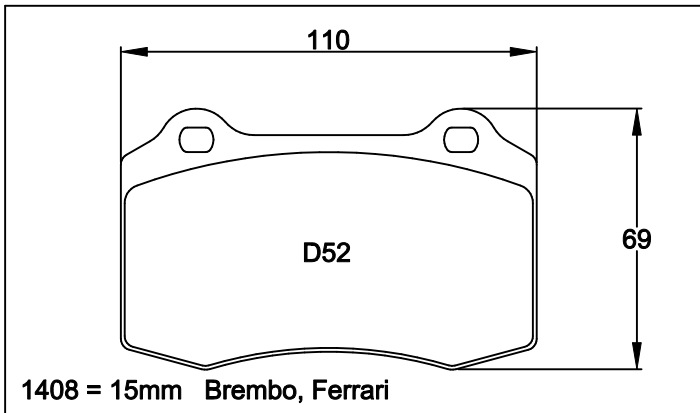
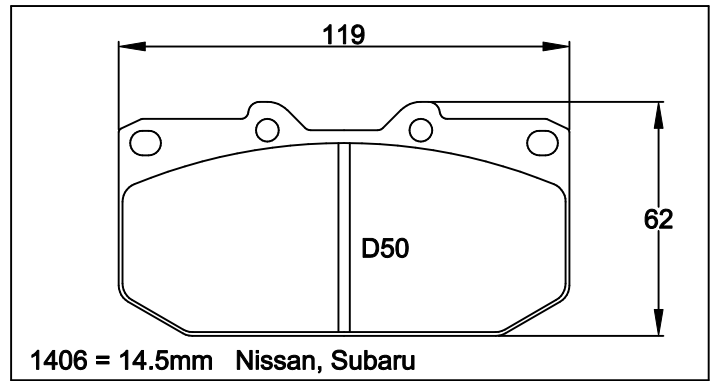
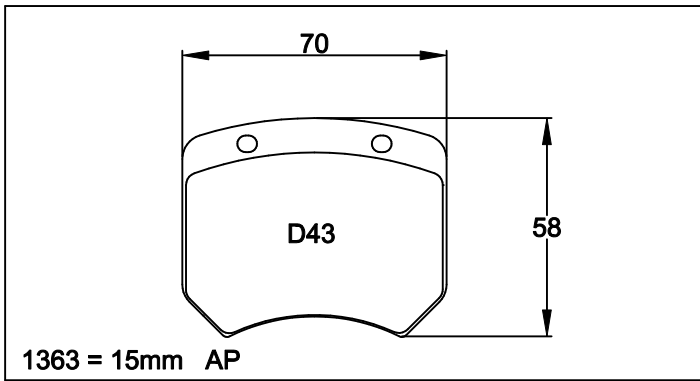

Illustrations are for identification purpose only. The right of modification in construction, design or model application is reserved.
Even if shown in the drawing, accessories such as clips, springs, rivets, wear indicators, damping shims etc. are generally not part of PAGID RS pads.

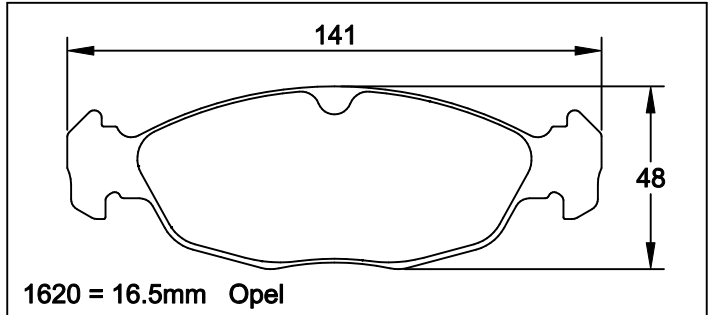
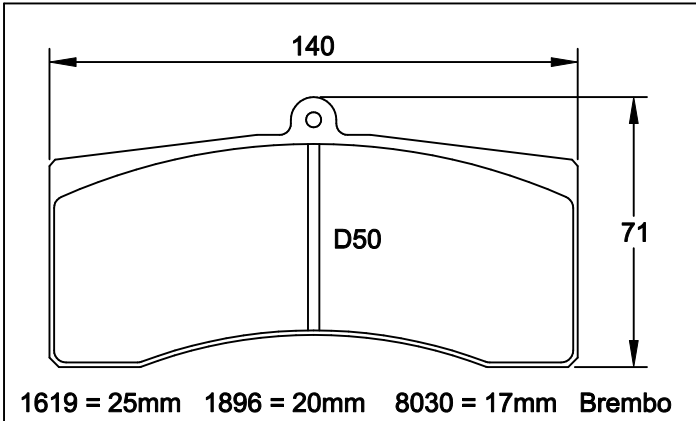
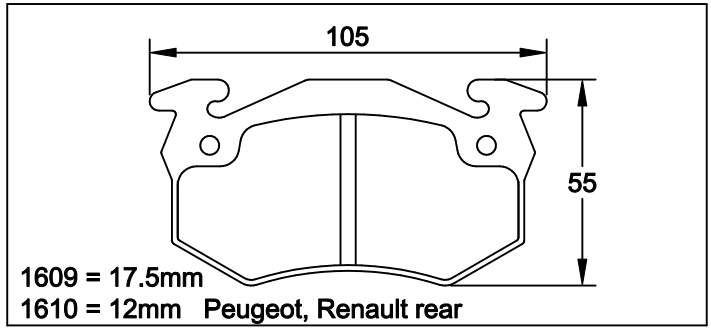
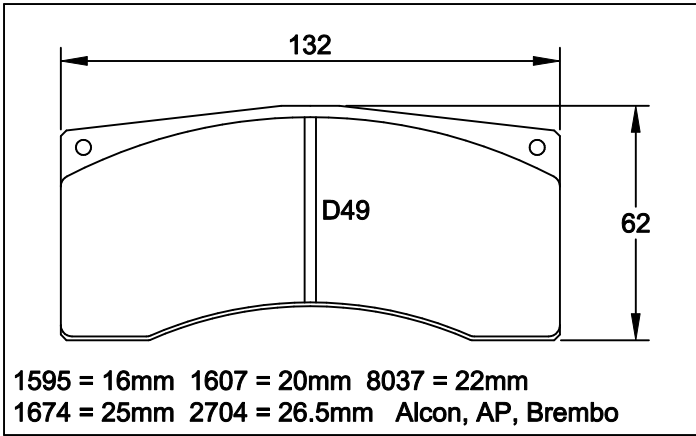

1674 see 1595

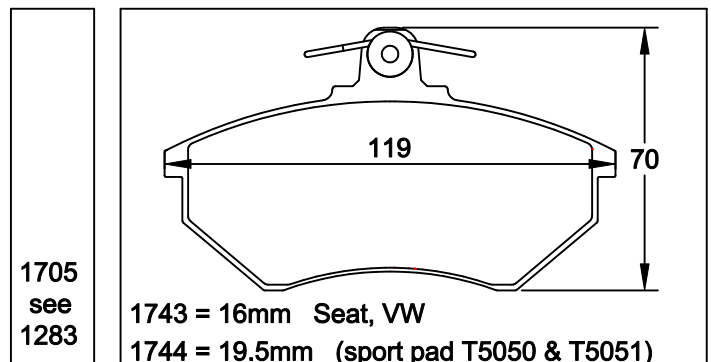
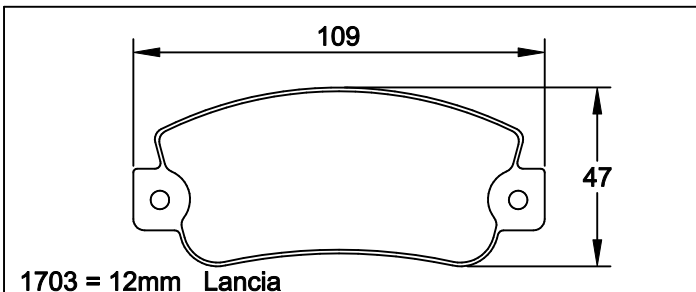
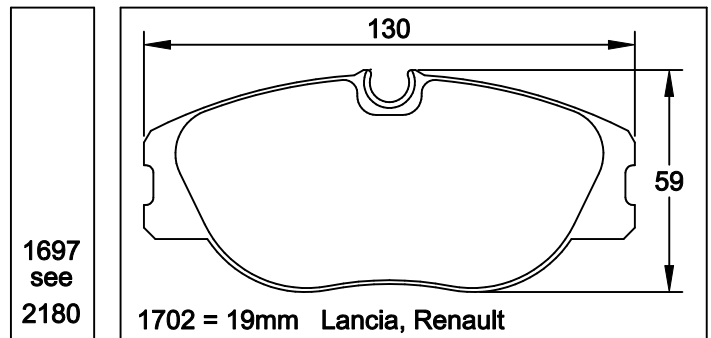
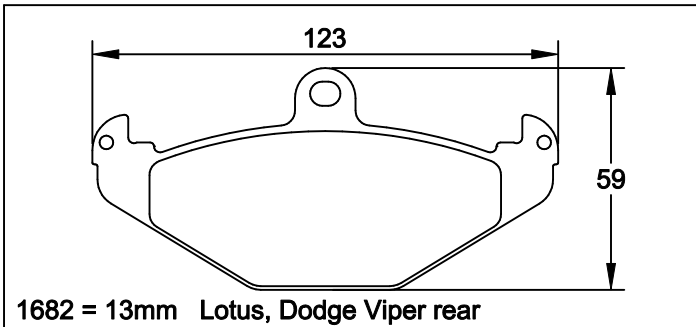
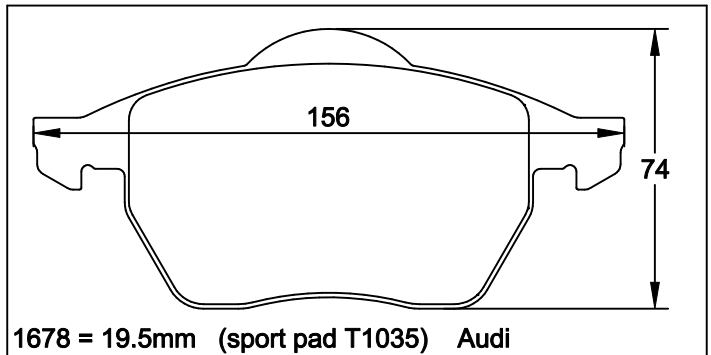
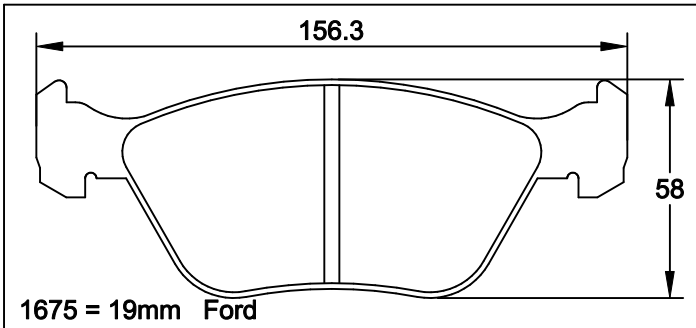

Illustrations are for identification purpose only. The right of modification in construction, design or model application is reserved.
Even if shown in the drawing, accessories such as clips, springs, rivets, wear indicators, damping shims etc. are generally not part of PAGID RS pads.

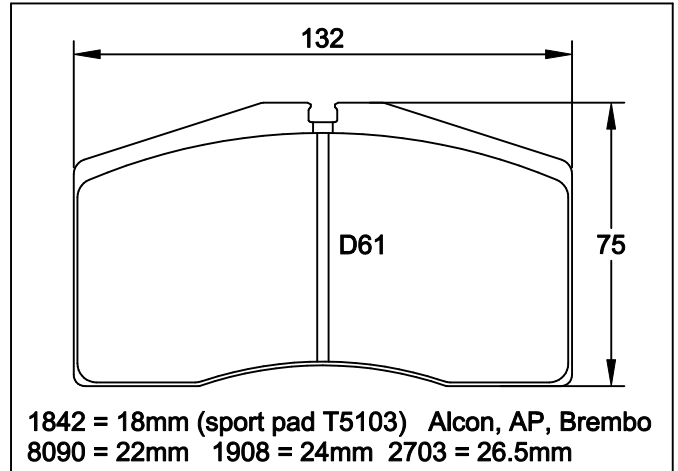
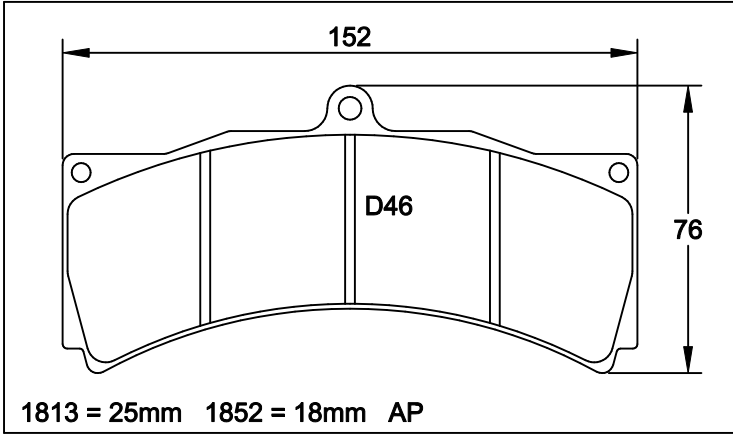
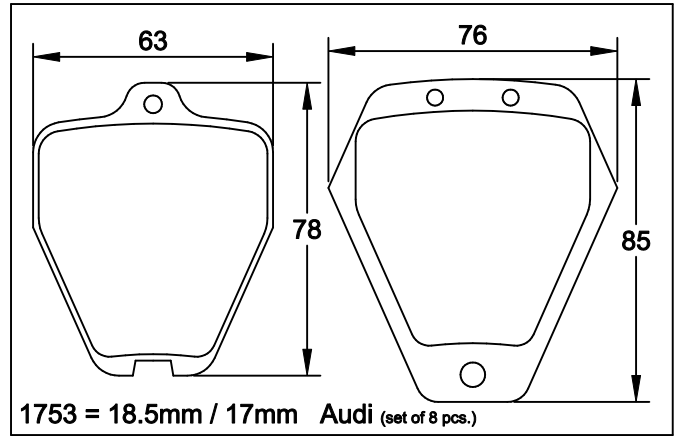
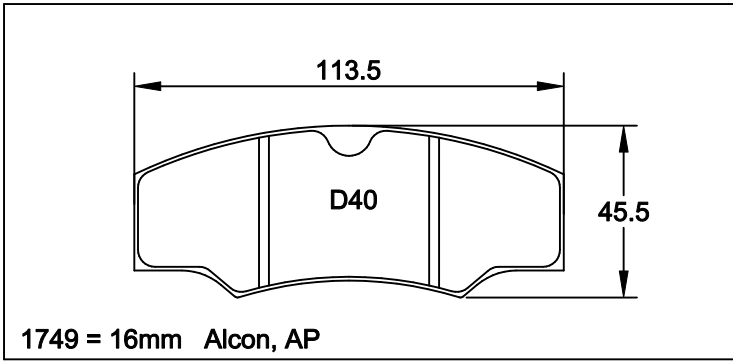

1852 see 1813 1896 see 1619

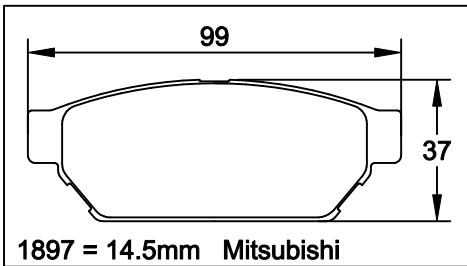

1903
see
1538

1908
see
1842

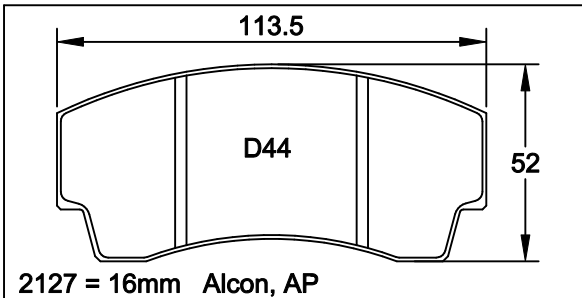
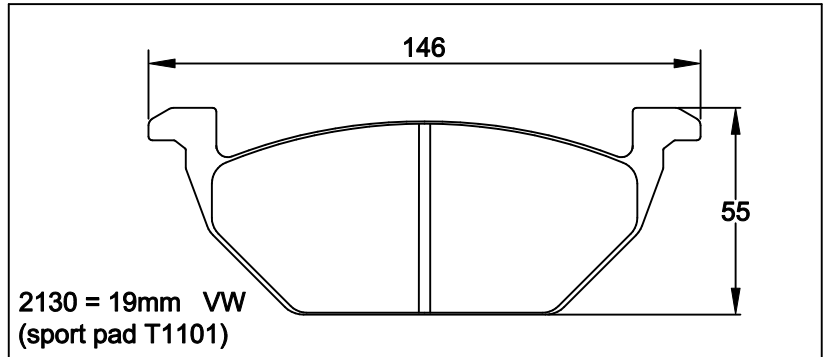
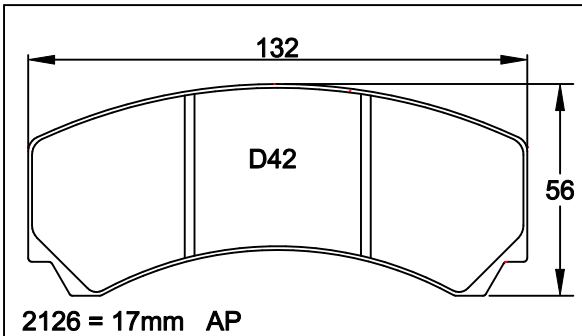
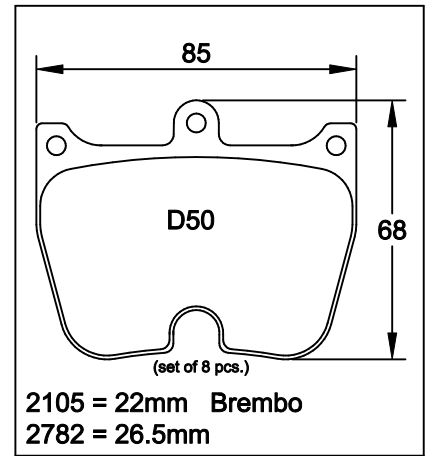
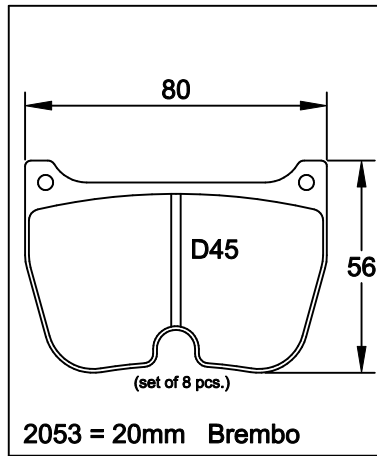

2179 see 1287

Illustrations are for identification purpose only. The right of modification in construction, design or model application is reserved.
Even if shown in the drawing, accessories such as clips, springs, rivets, wear indicators, damping shims etc. are generally not part of PAGID RS pads.

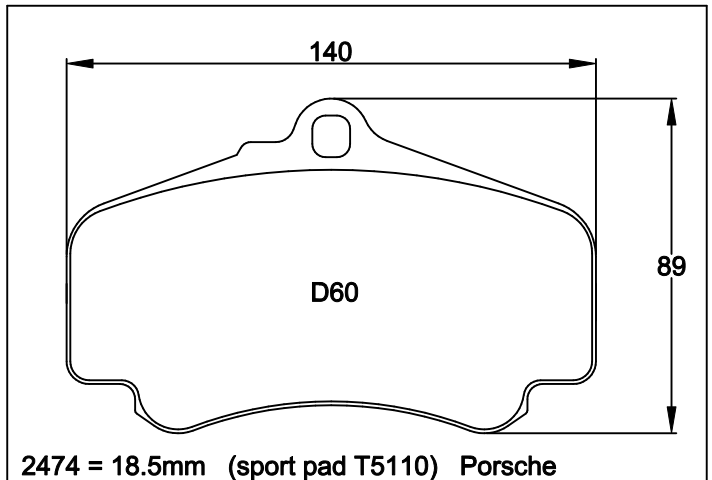
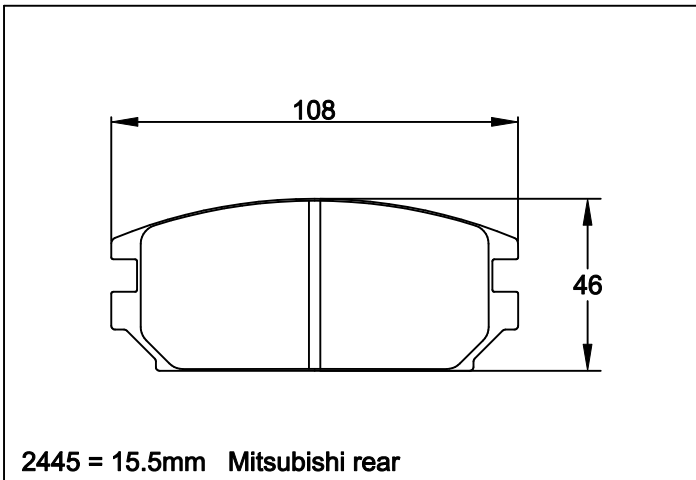
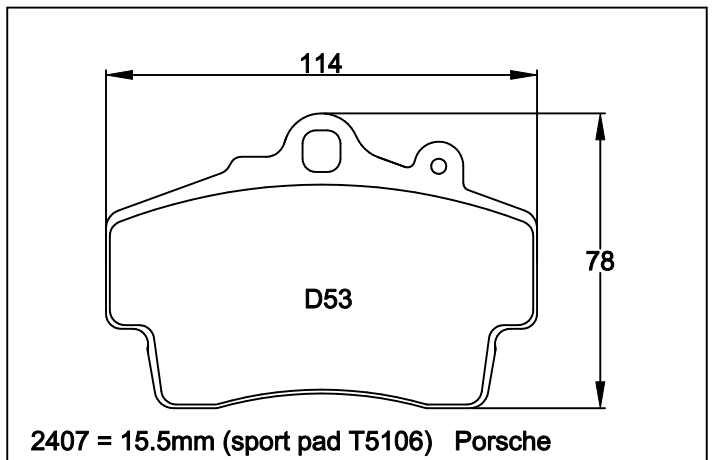
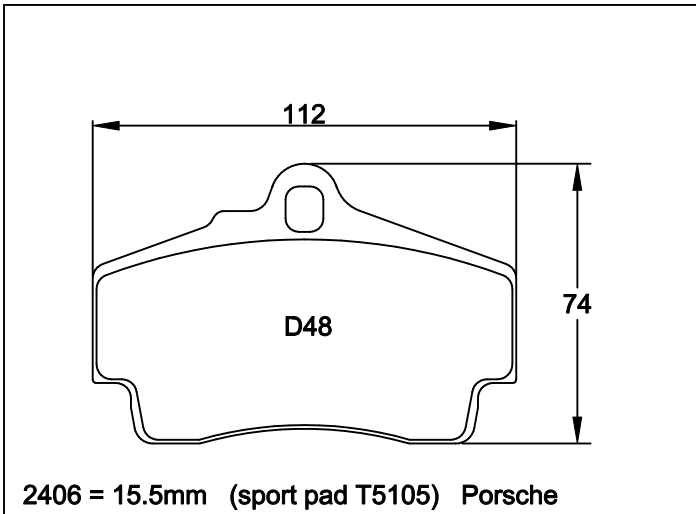
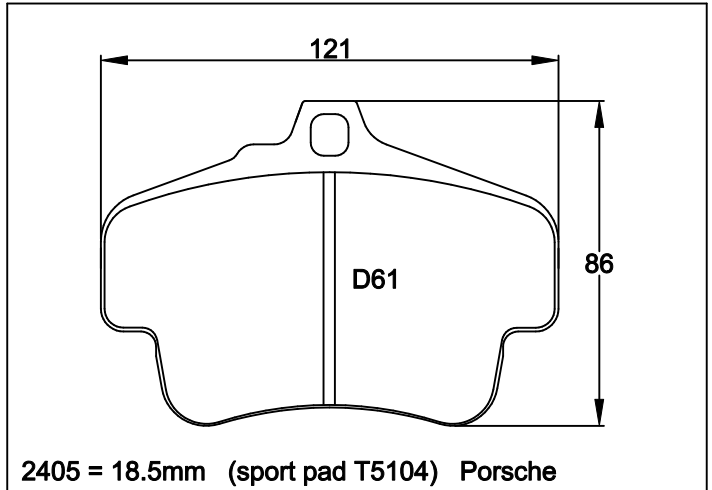
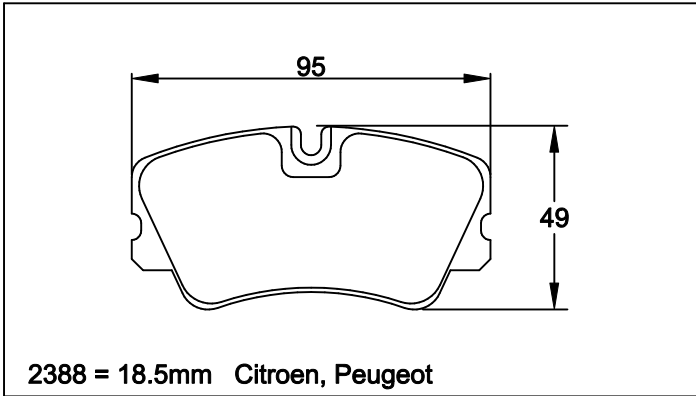
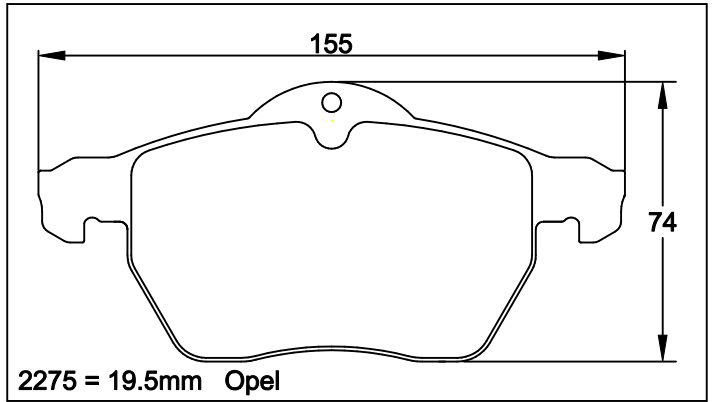
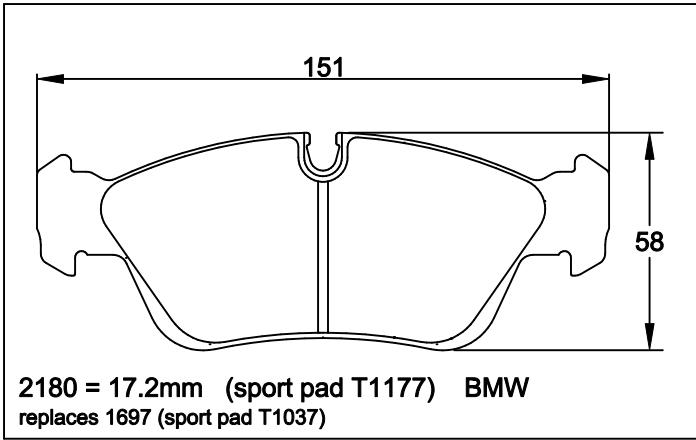

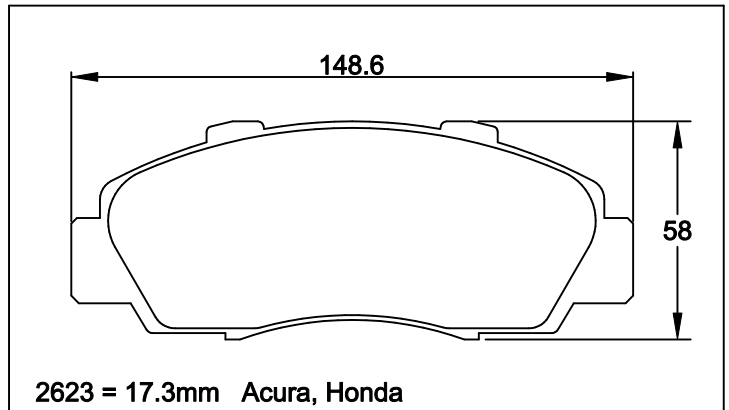
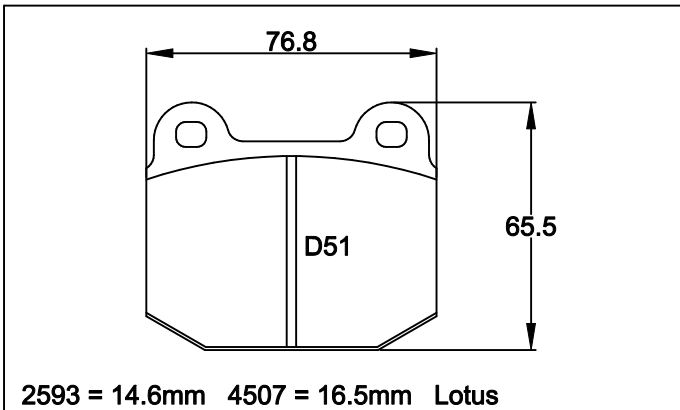
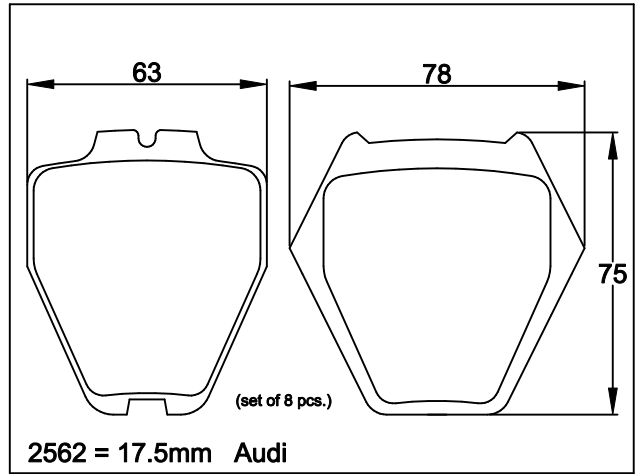
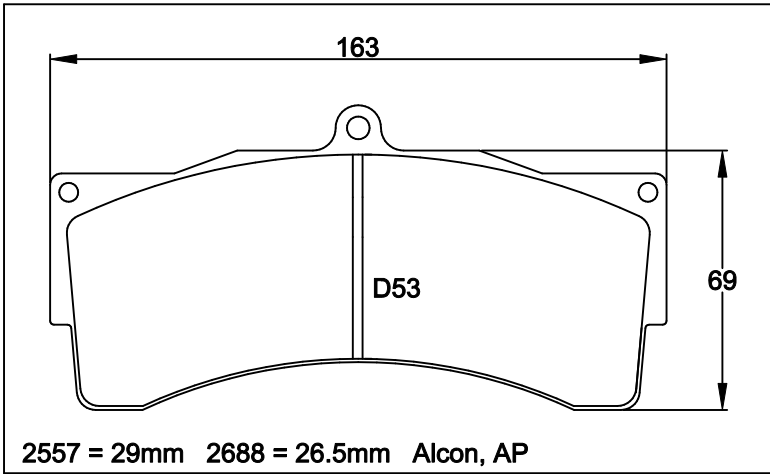
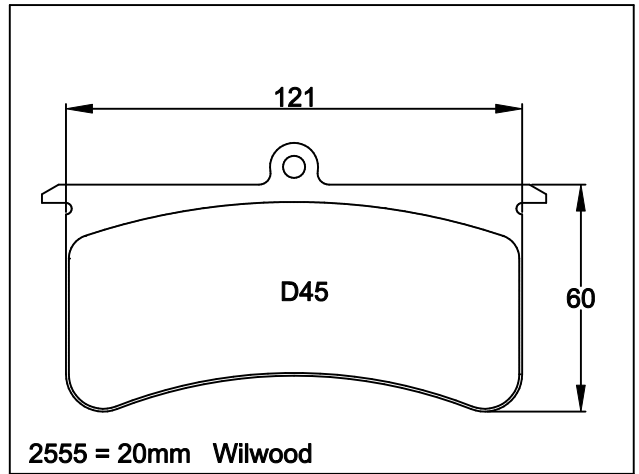
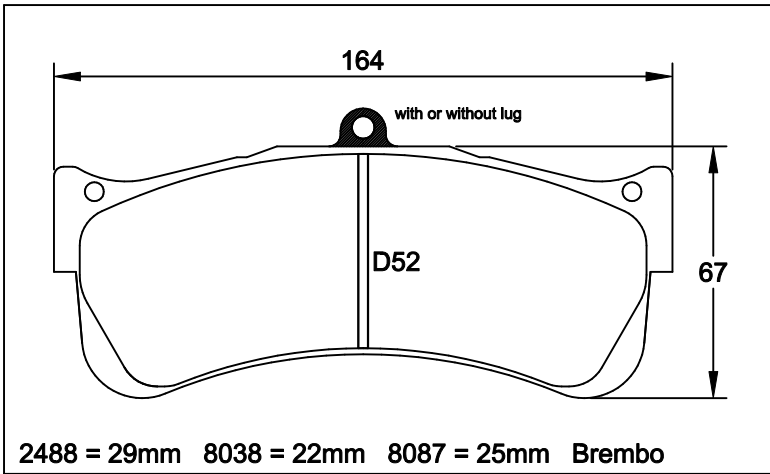
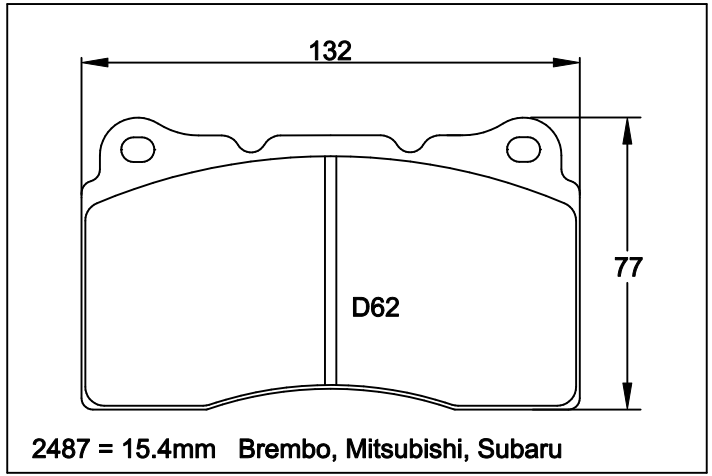
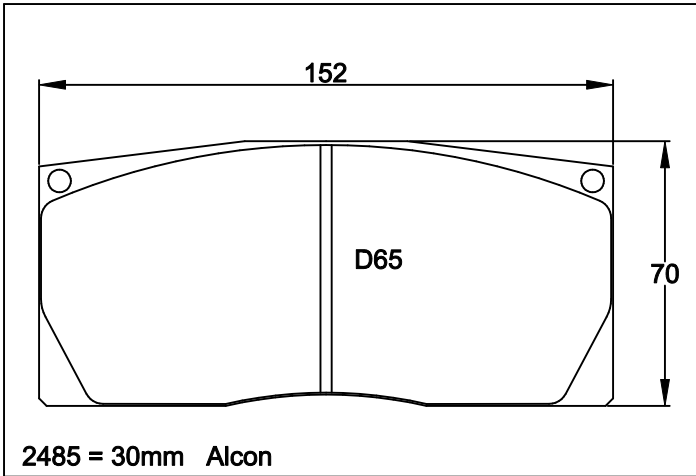

Illustrations are for identification purpose only. The right of modification in construction, design or model application is reserved. Even if shown in the drawing, accessories such as clips, springs, rivets, wear indicators, damping shims etc. are generally not part of PAGID RS pads.

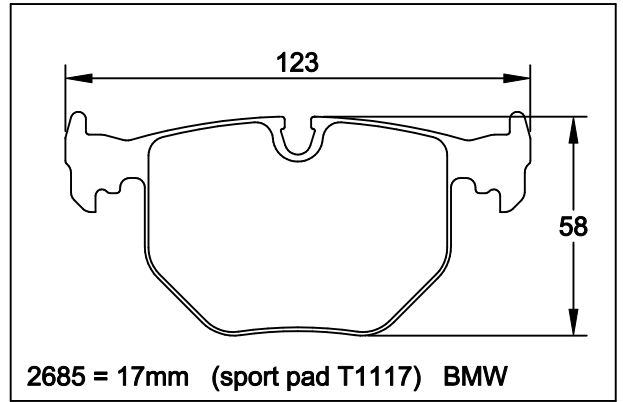
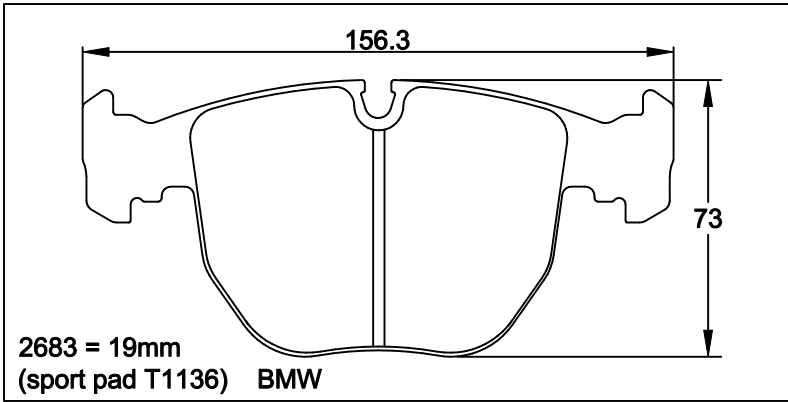

2688 see 2557

2703 see 1842

2704 see 1595

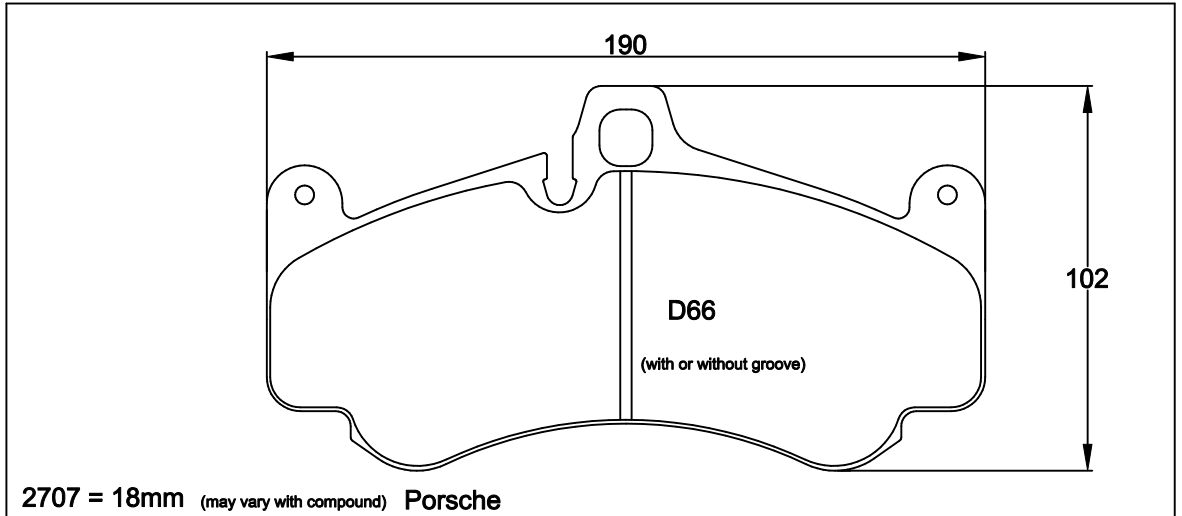

2723 see 4304

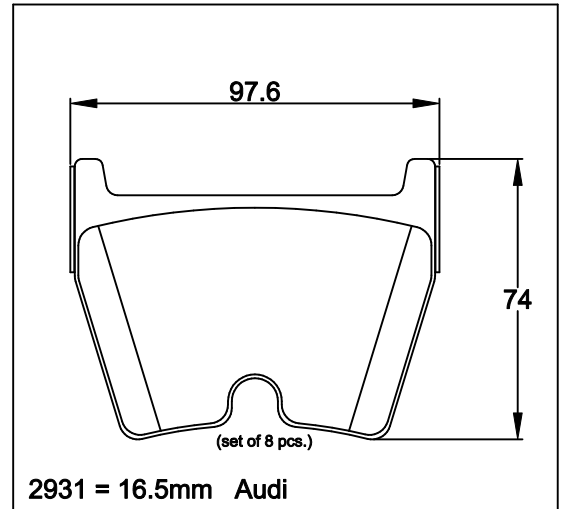
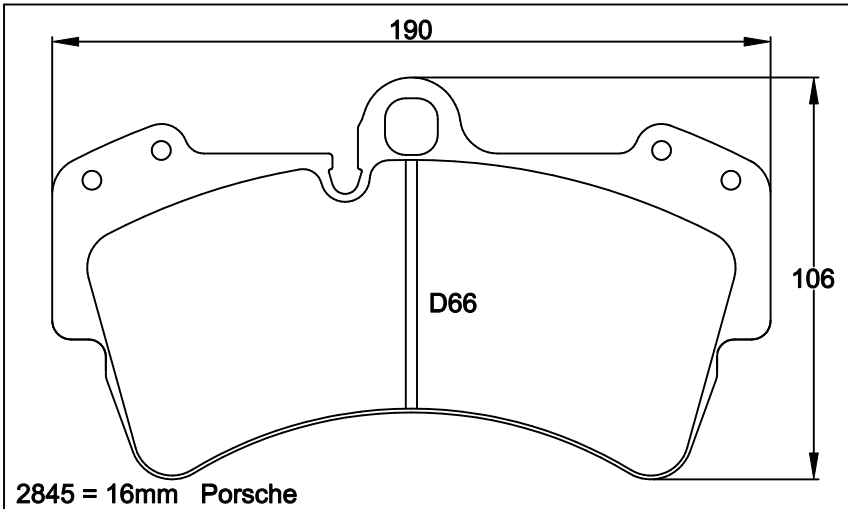
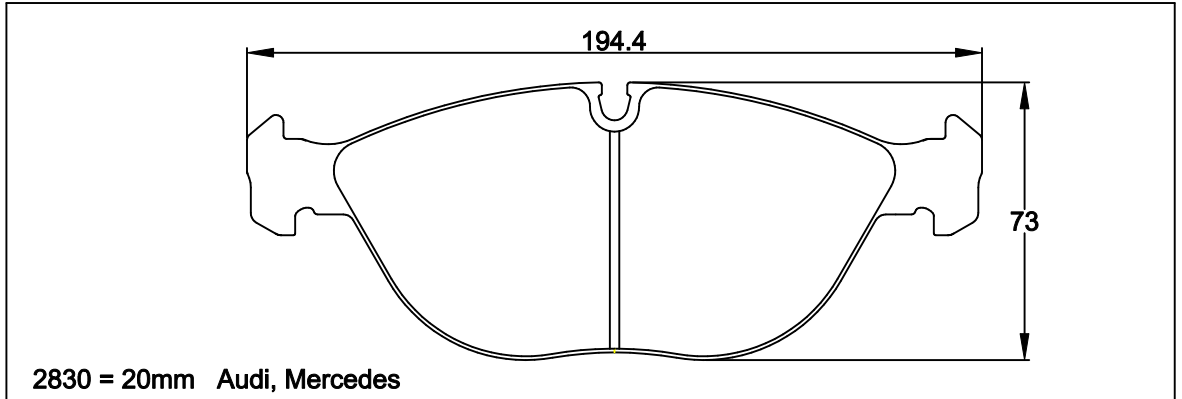

Illustrations are for identification purpose only. The right of modification in construction, design or model application is reserved.
Even if shown in the drawing, accessories such as clips, springs, rivets, wear indicators, damping shims etc. are generally not part of PAGID RS pads.

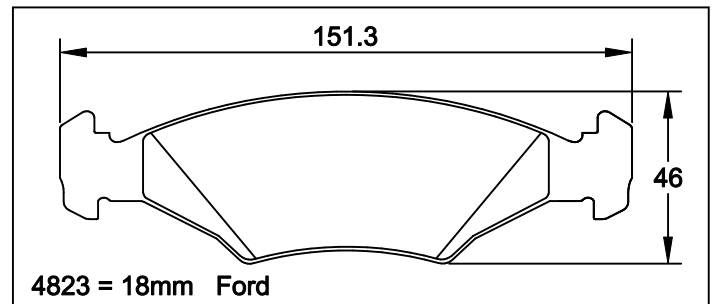
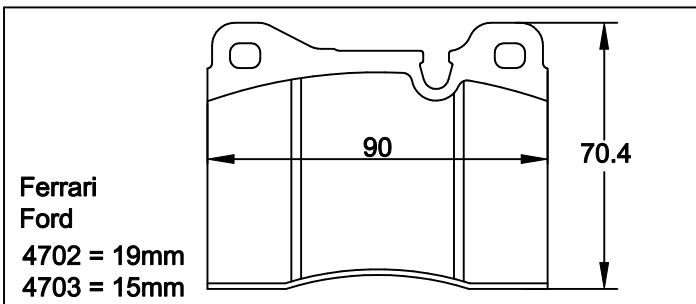
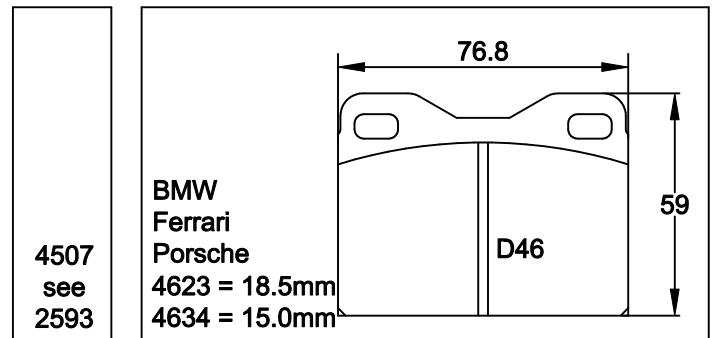
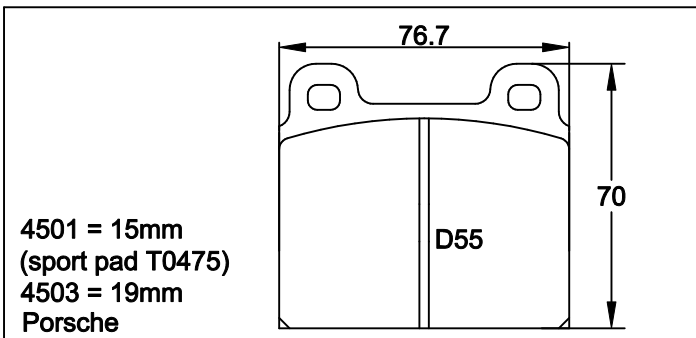
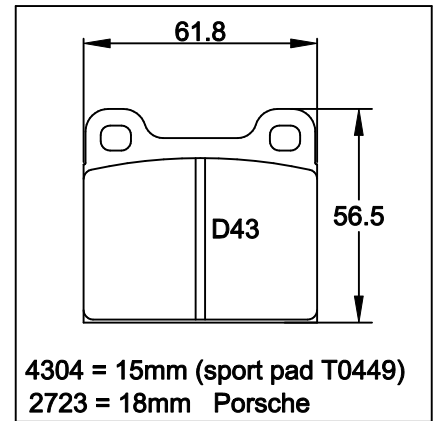
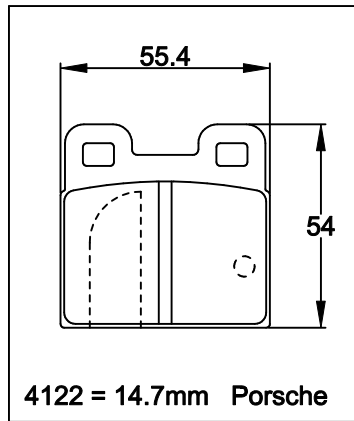
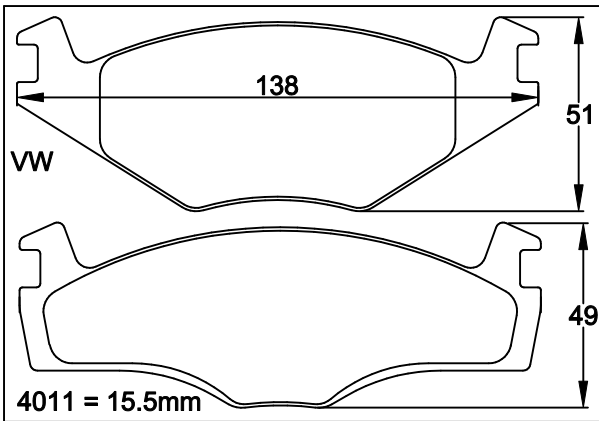
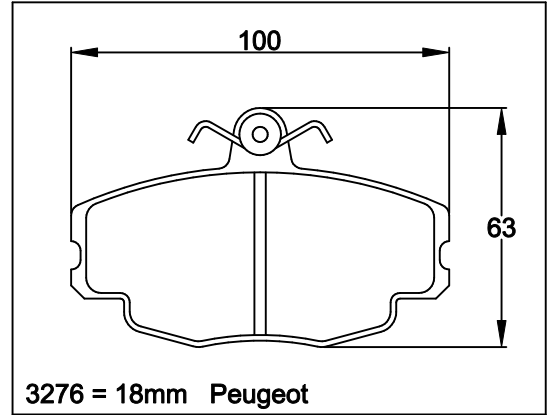
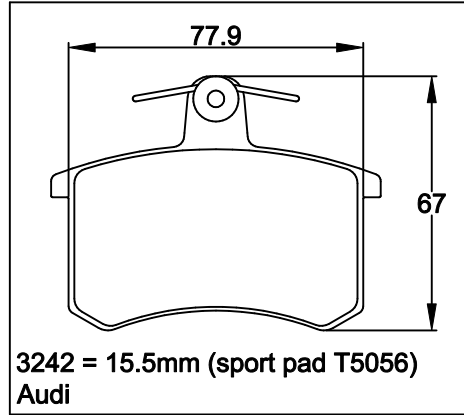
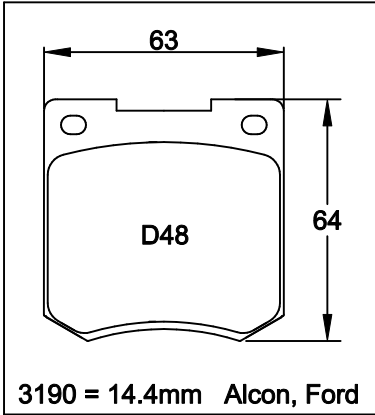
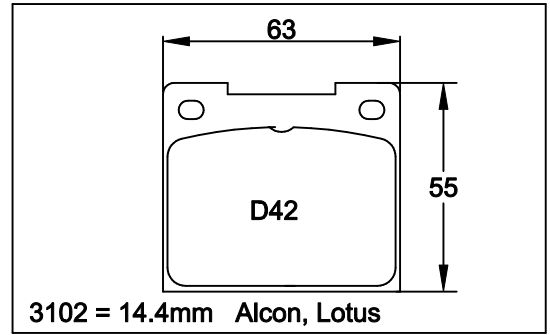
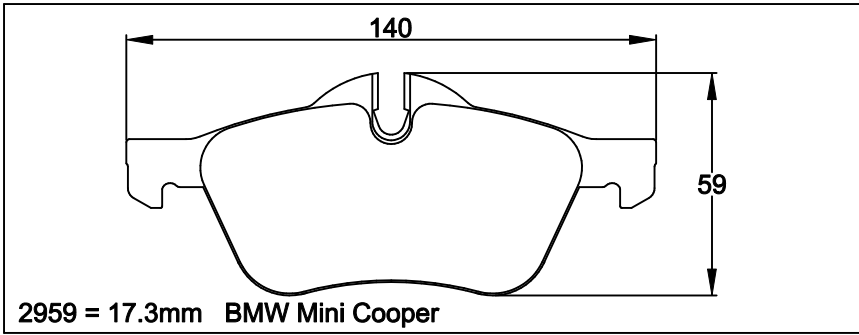

Illustrations are for identification purpose only. The right of modification in construction, design or model application is reserved. Even if shown in the drawing, accessories such as clips, springs, rivets, wear indicators, damping shims etc. are generally not part of PAGID RS pads.

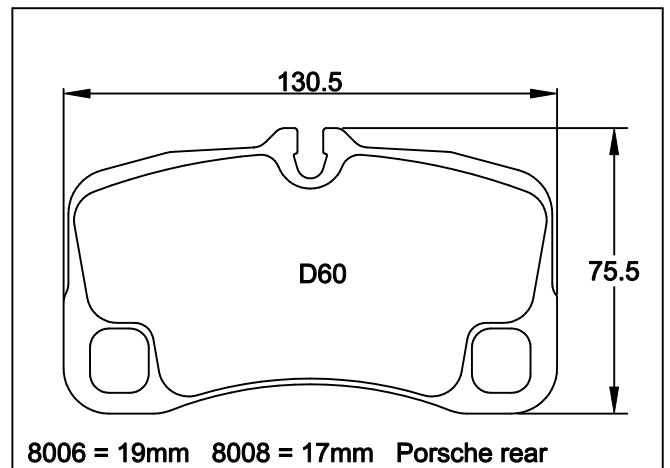
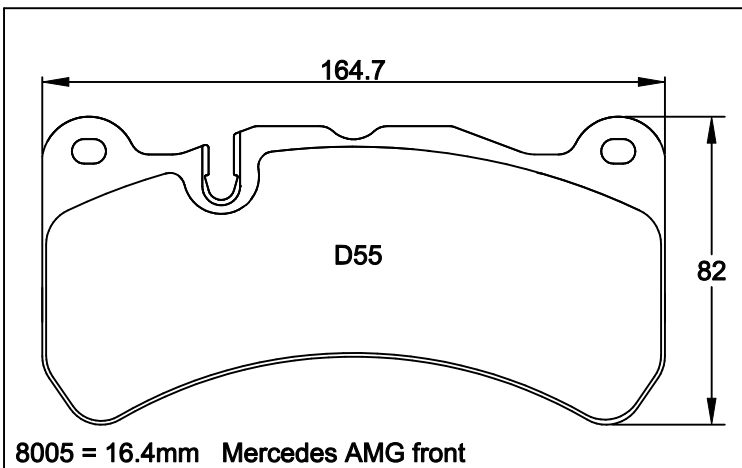
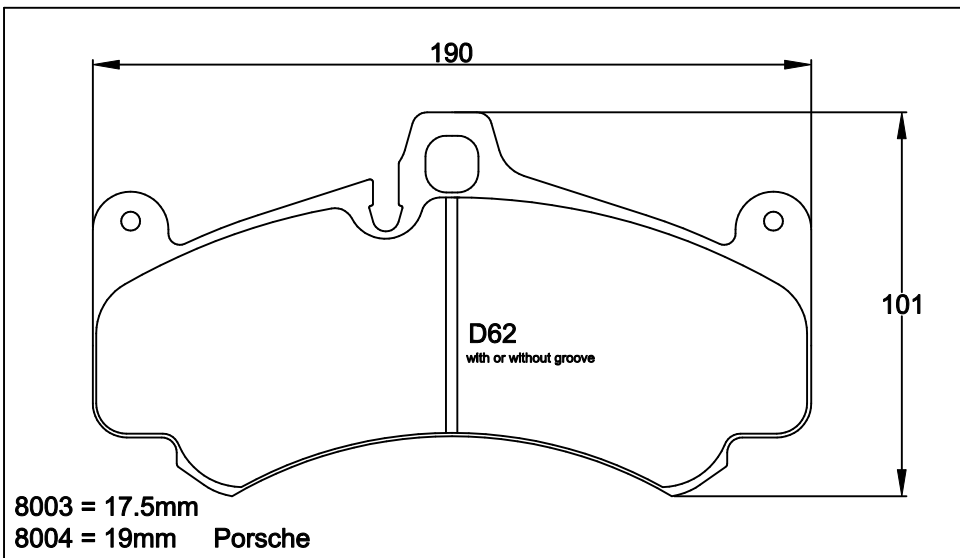
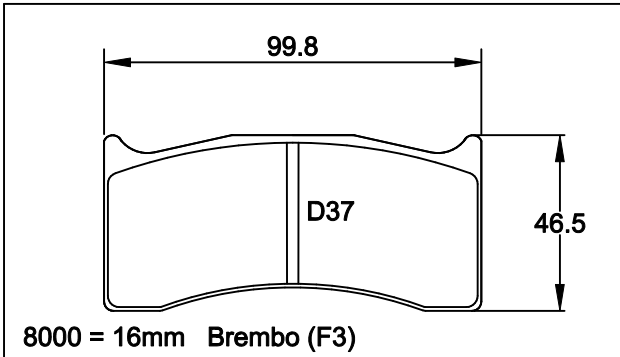
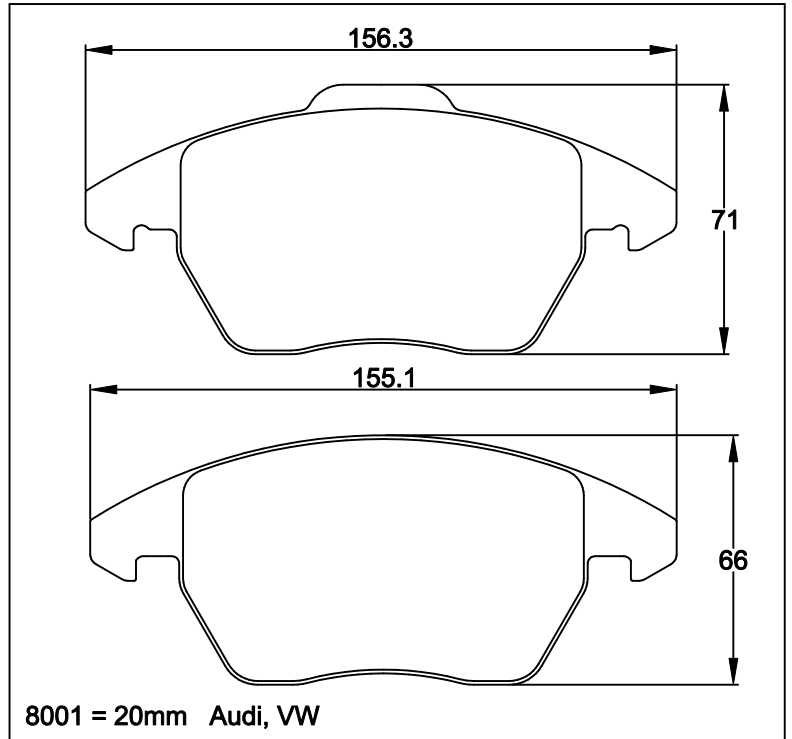
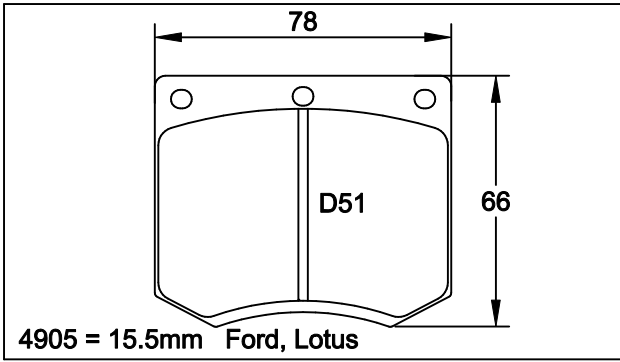

8009 see 1203

8018 see 1538

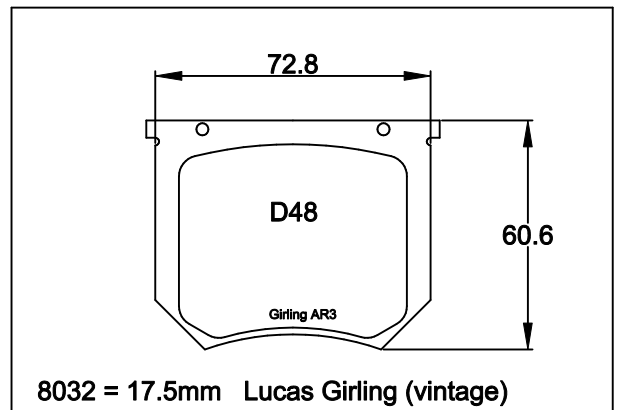
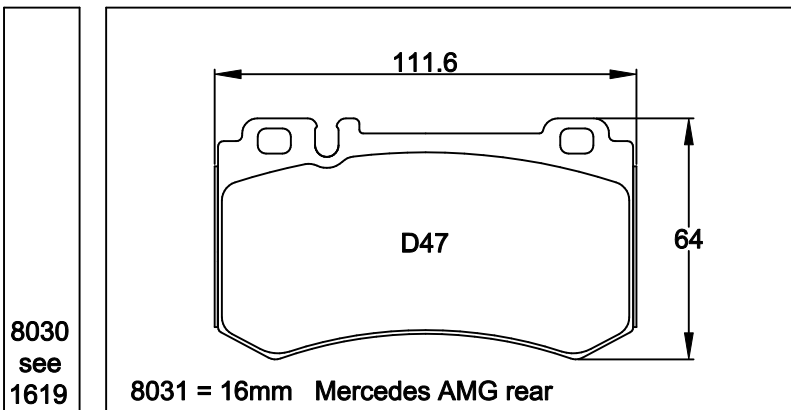
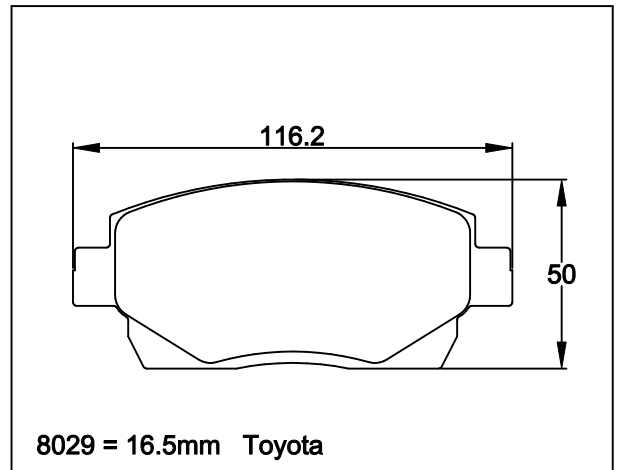
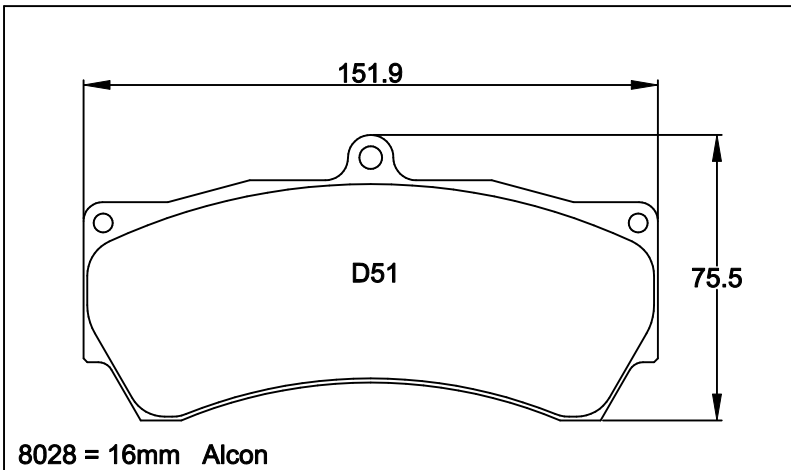
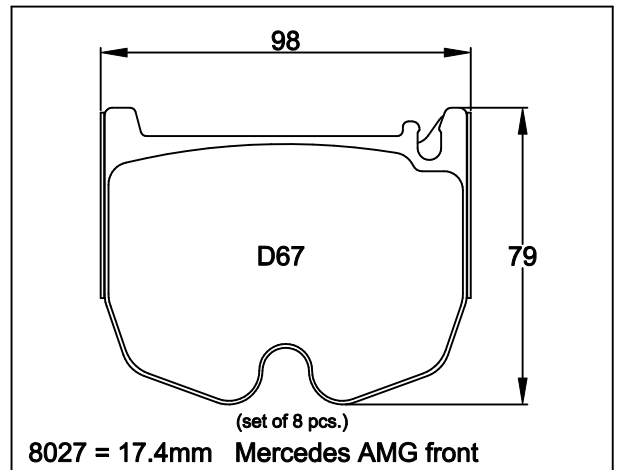
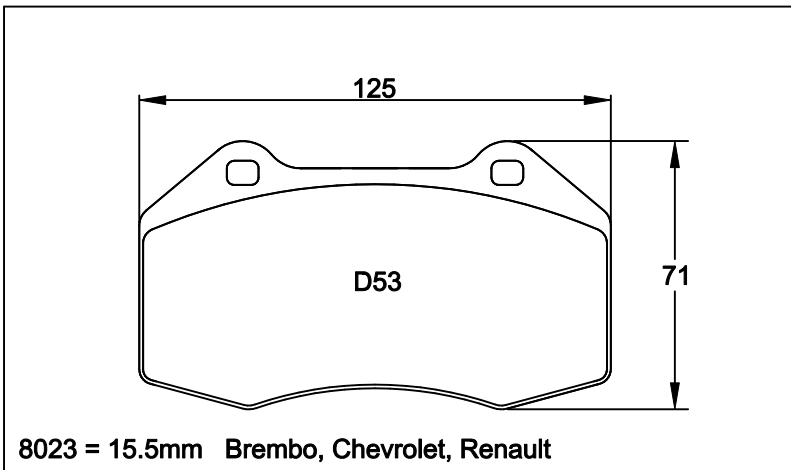
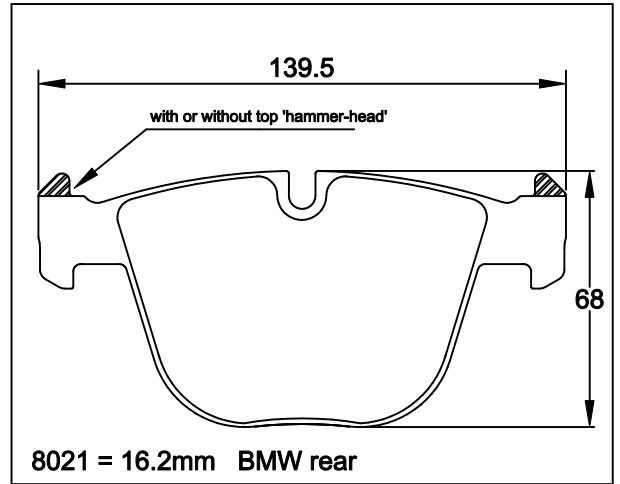
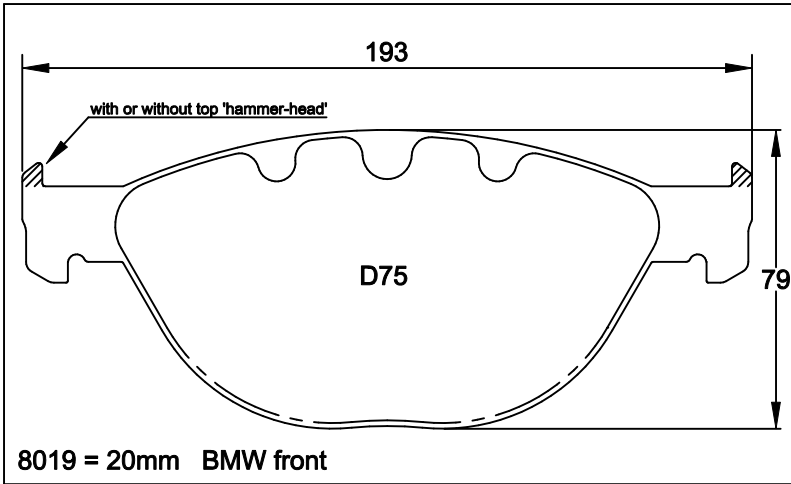

8030
see
1619

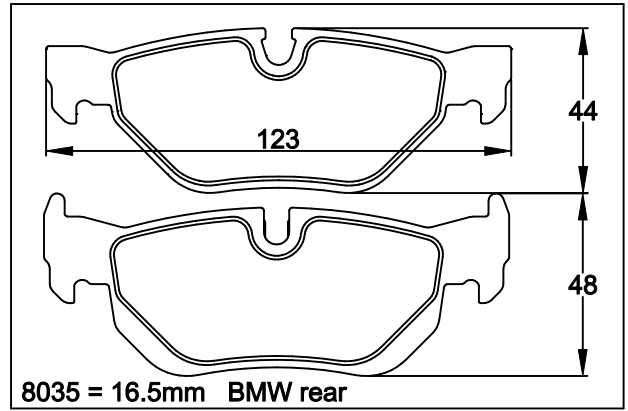
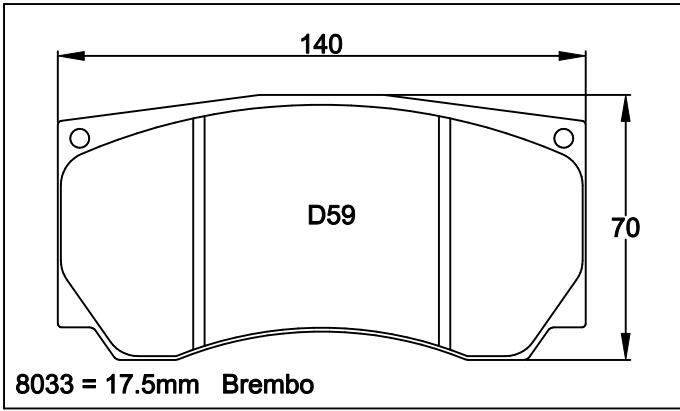

8037
see
1595

8038
see
2488

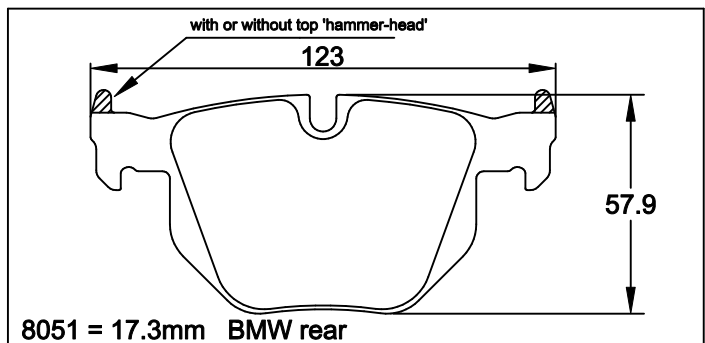
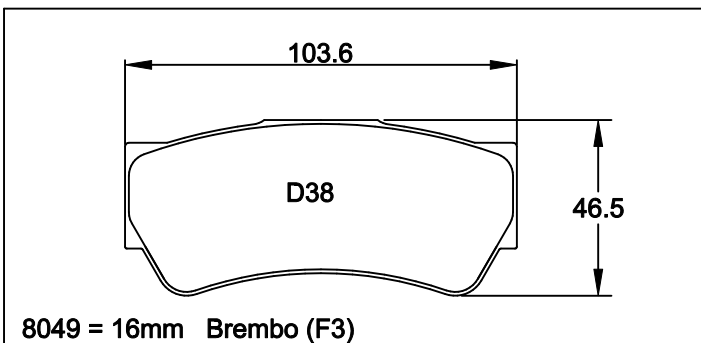
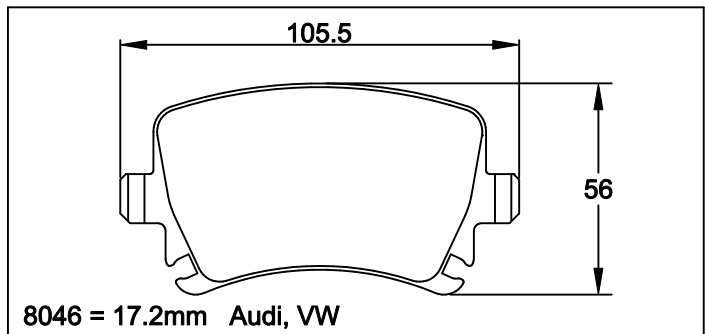
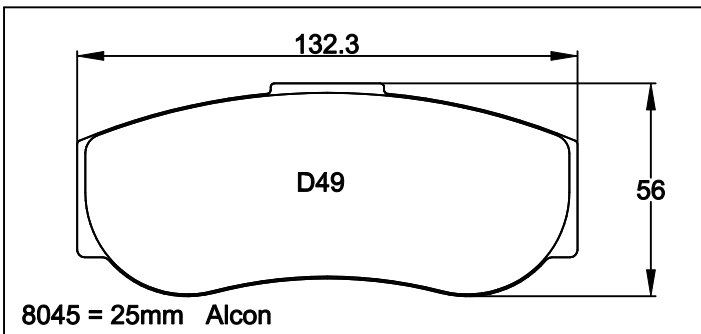
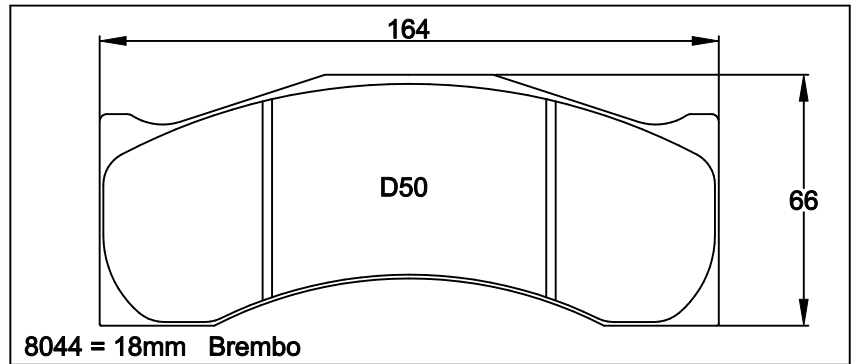
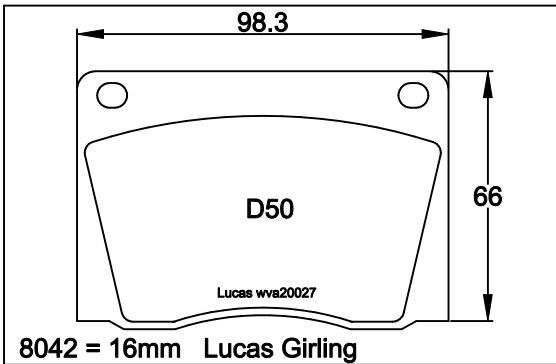
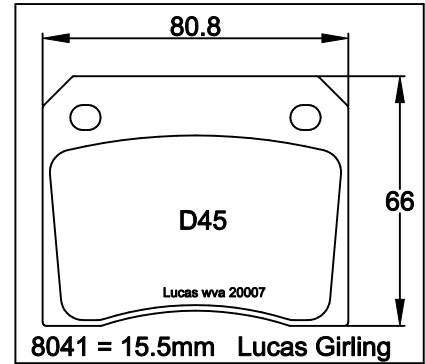
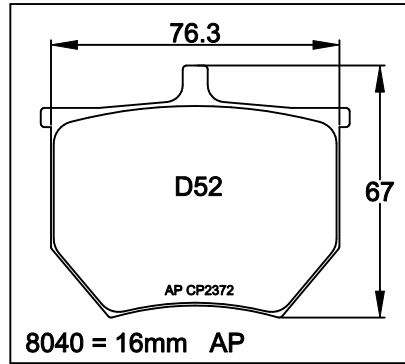
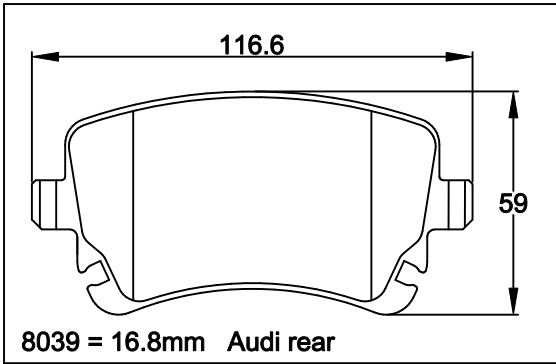

Illustrations are for identification purpose only. The right of modification in construction, design or model application is reserved.
Even if shown in the drawing, accessories such as clips, springs, rivets, wear indicators, damping shims etc. are generally not part of PAGID RS pads.

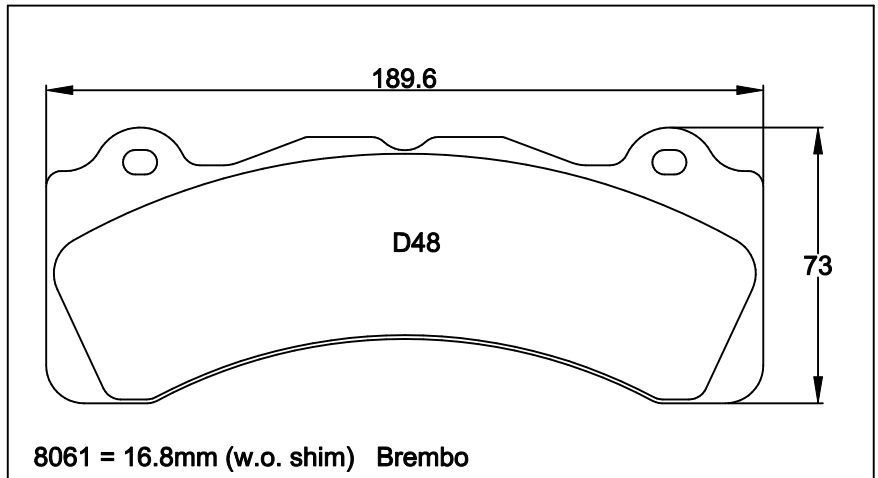
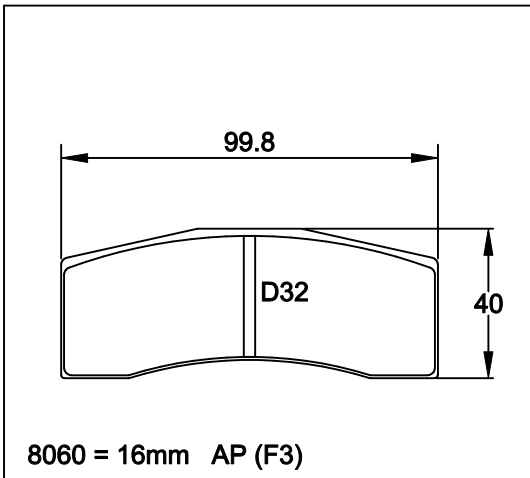
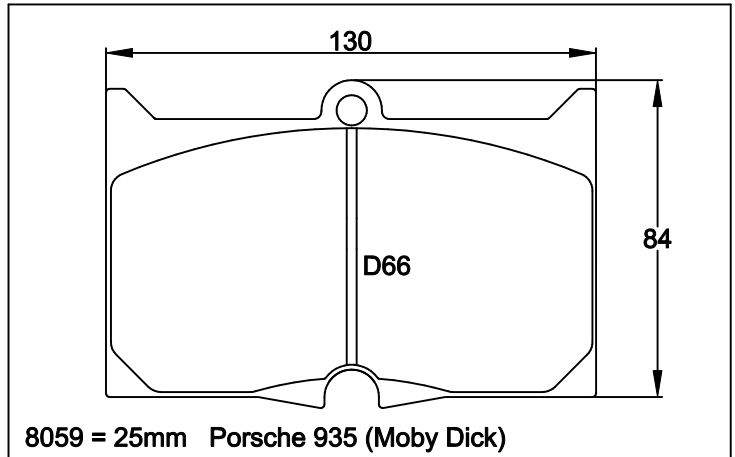
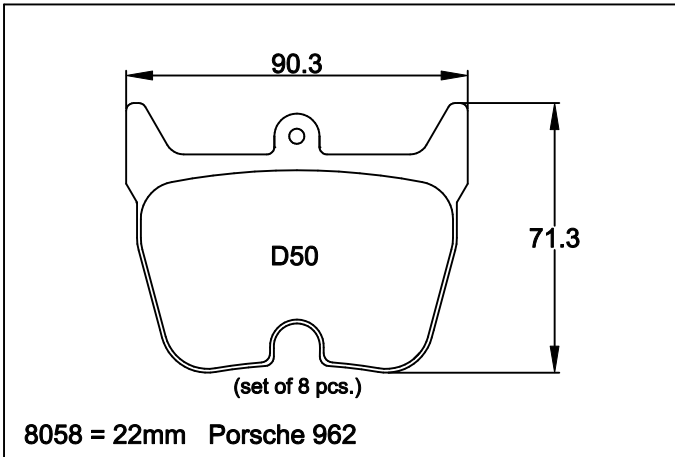
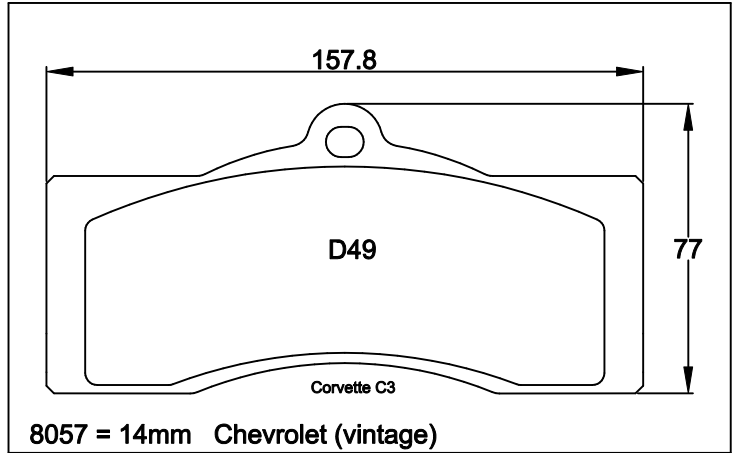
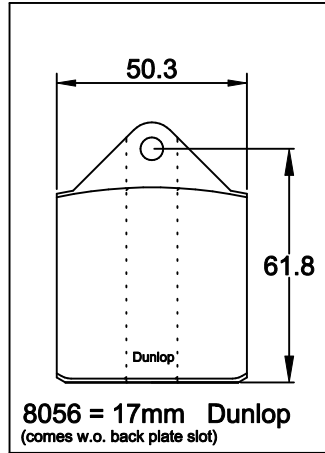
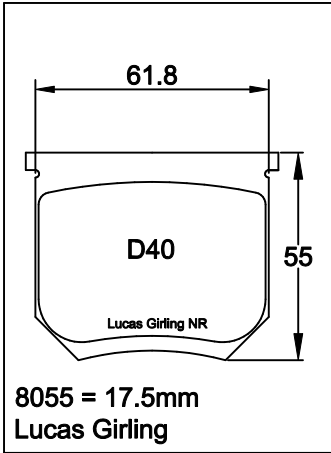
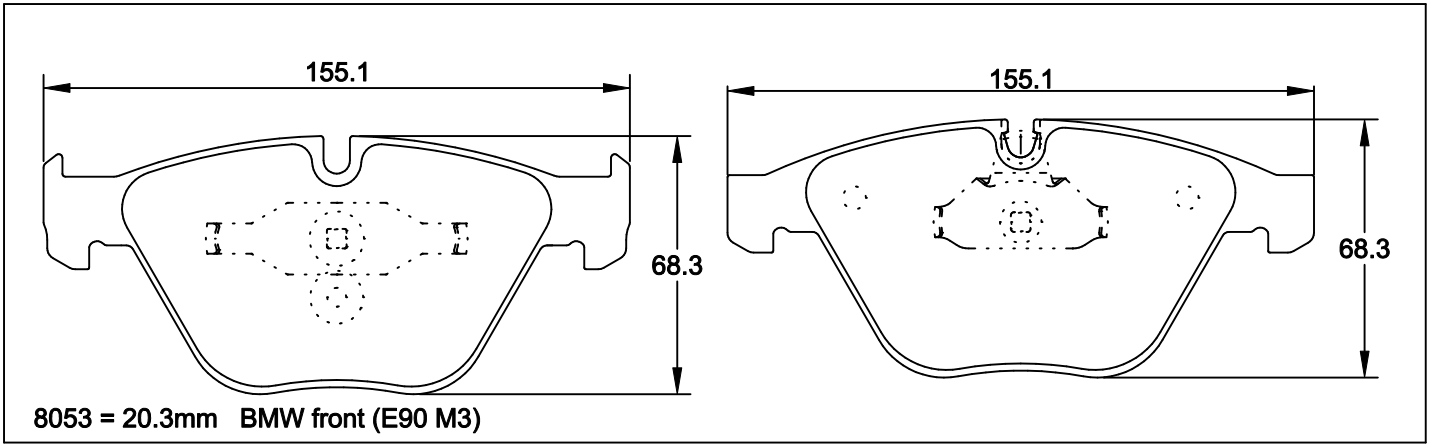

Illustrations are for identification purpose only. The right of modification in construction, design or model application is reserved. Even if shown in the drawing, accessories such as clips, springs, rivets, wear indicators, damping shims etc. are generally not part of PAGID RS pads.

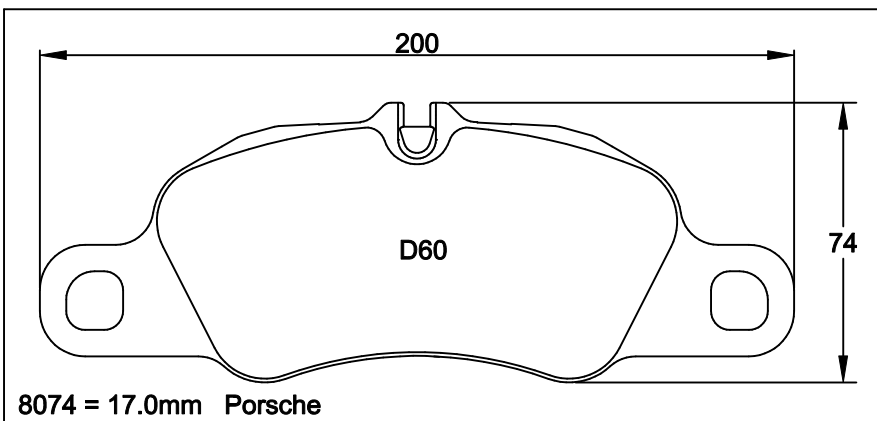
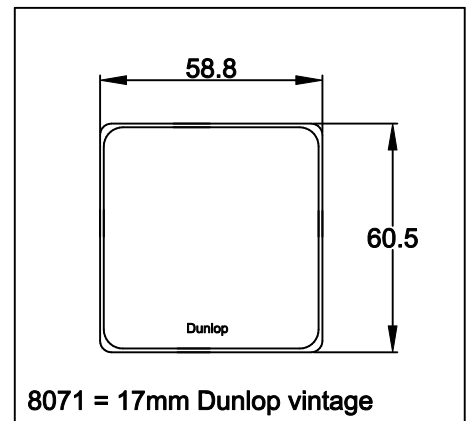
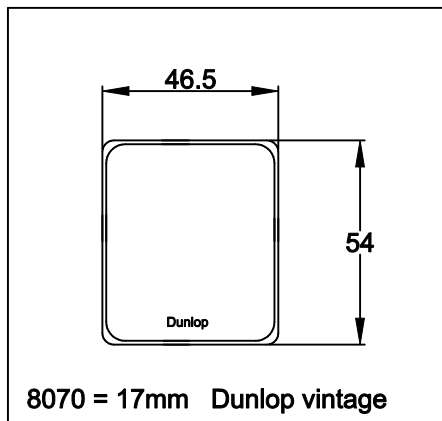
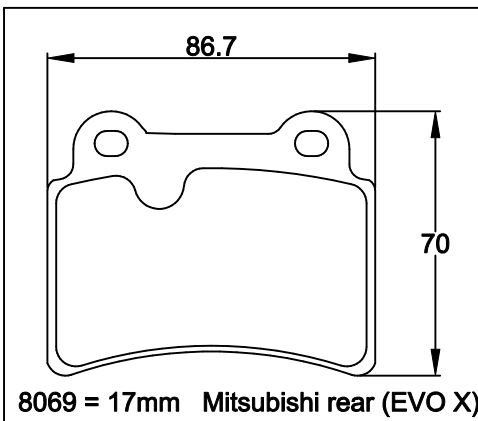
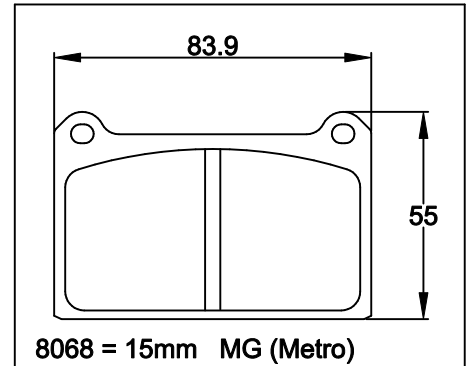
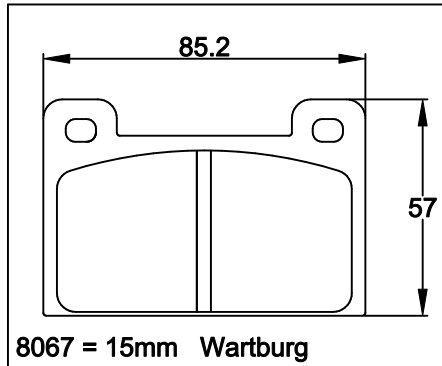
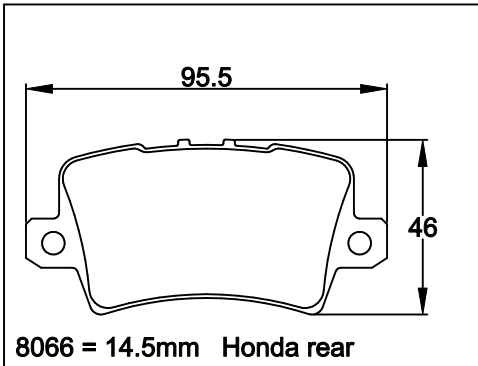
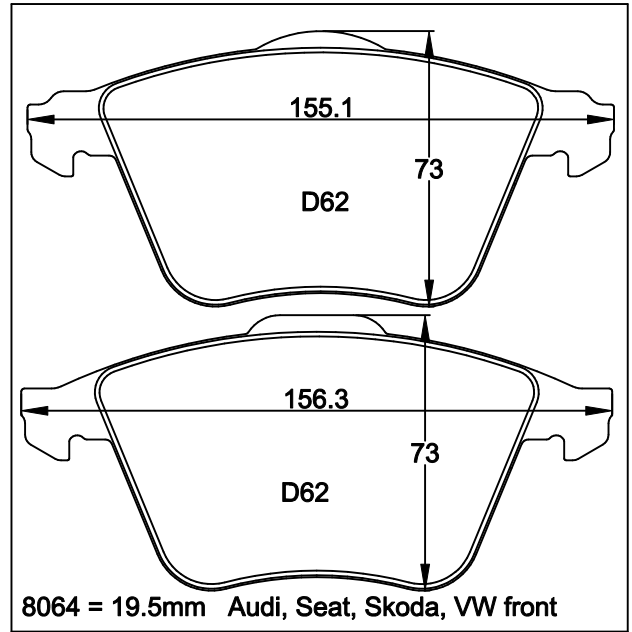
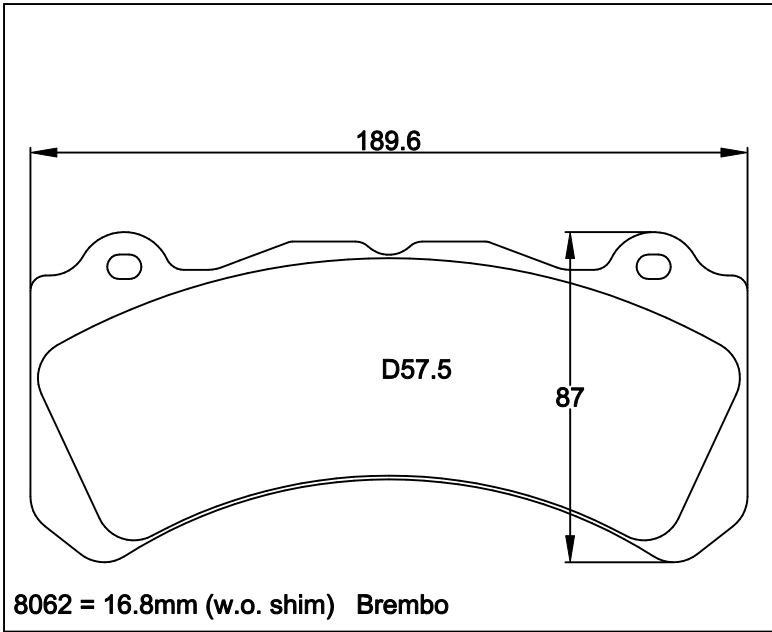

8076 see 20349

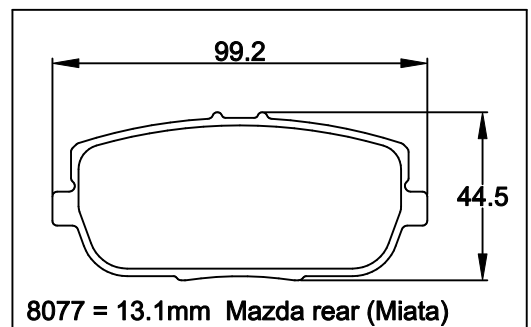

Illustrations are for identification purpose only. The right of modification in construction, design or model application is reserved. Even if shown in the drawing, accessories such as clips, springs, rivets, wear indicators, damping shims etc. are generally not part of PAGID RS pads.

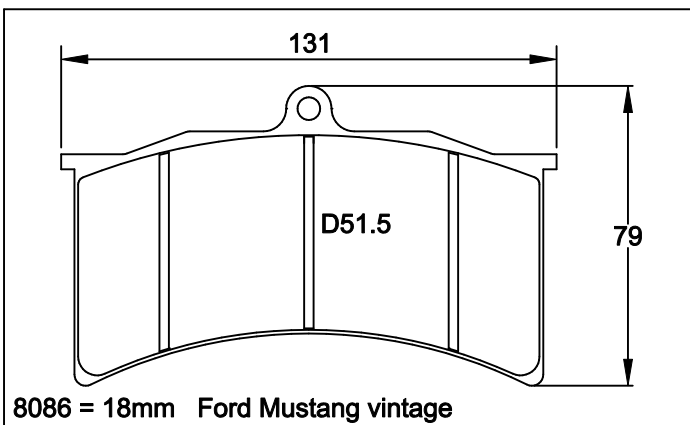
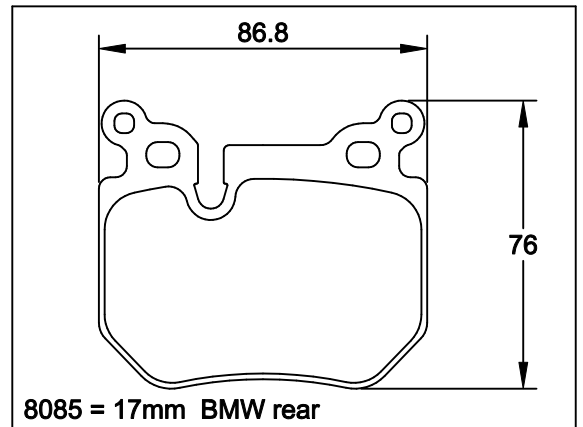
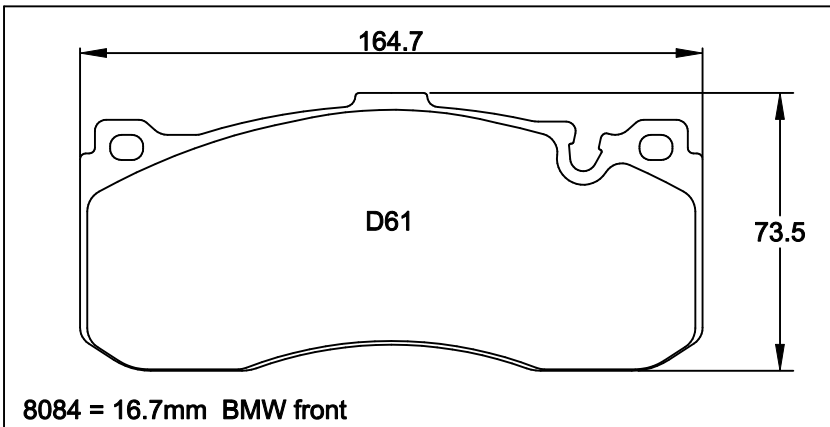
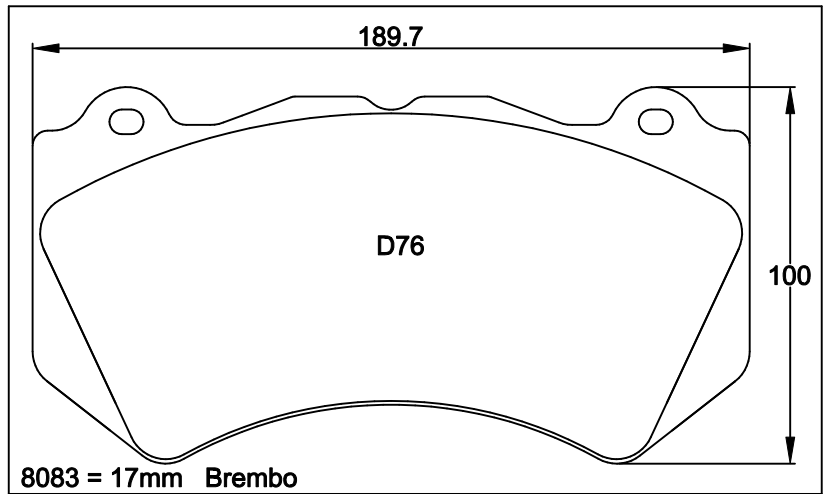
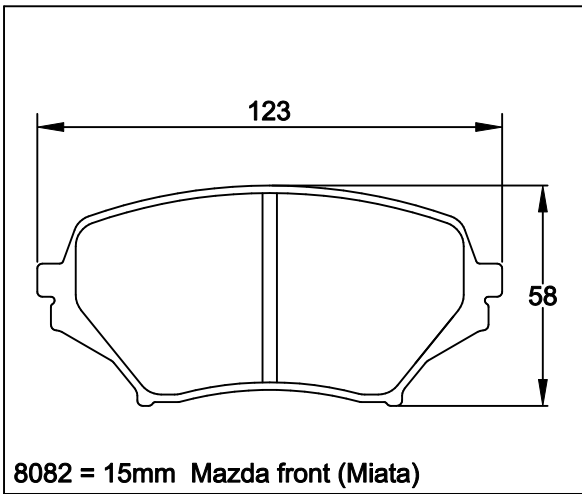
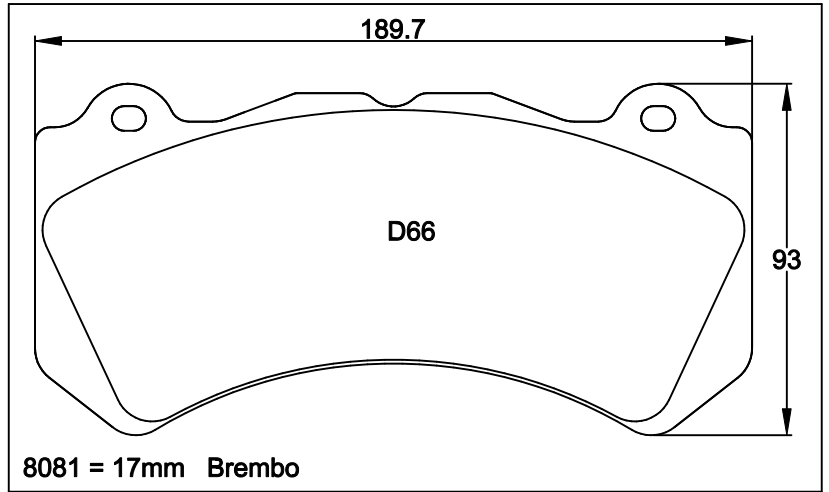
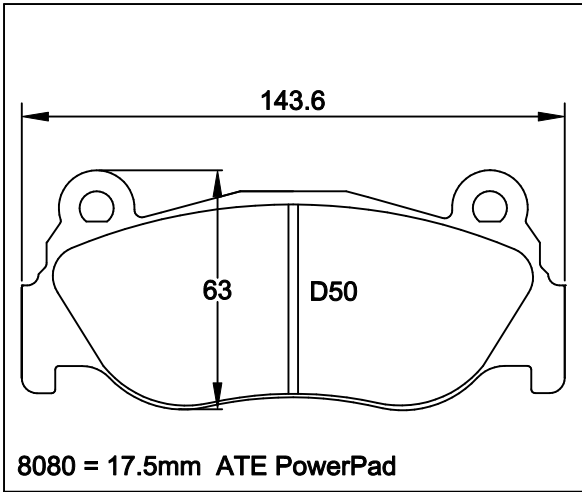

8087
see
2488

8090
see
1842



Illustrations are for identification purpose only. The right of modification in construction, design or model application is reserved. Even if shown in the drawing, accessories such as clips, springs, rivets, wear indicators, damping shims etc. are generally not part of PAGID RS pads.

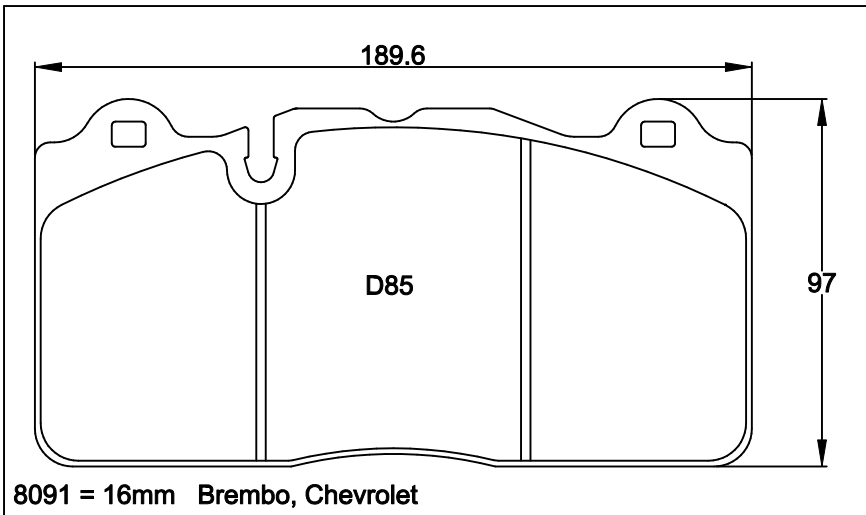

8091 = 16mm Brembo, Chevrolet

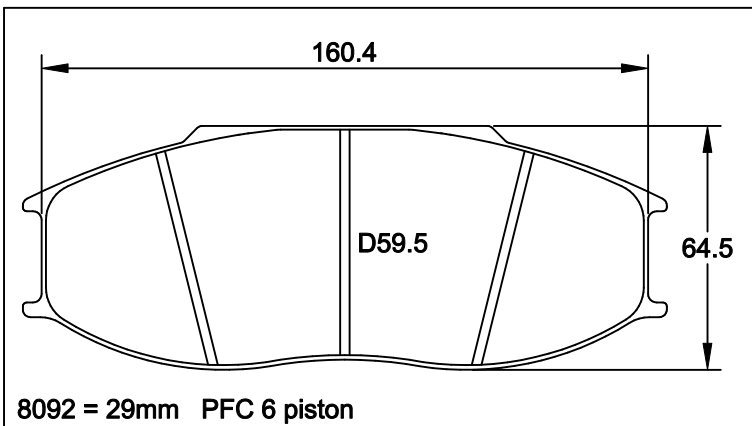

8092 = 29mm PFC 6 piston

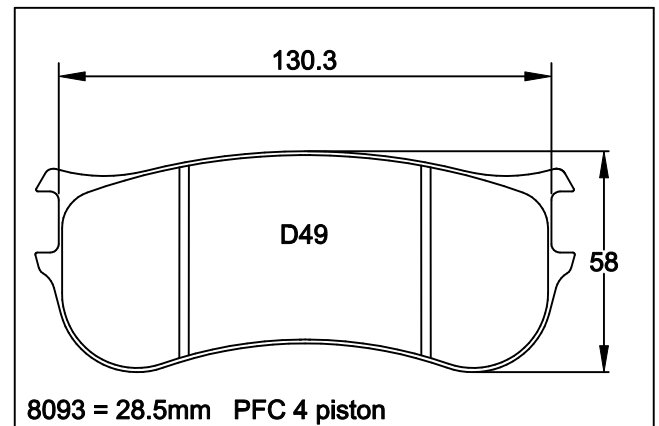

8093 = 28.5mm PFC 4 piston

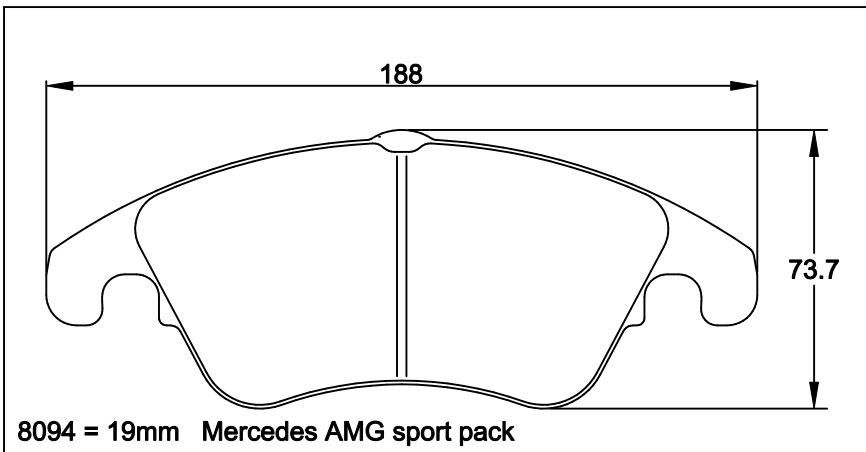

8094 = 19mm Mercedes AMG sport pack

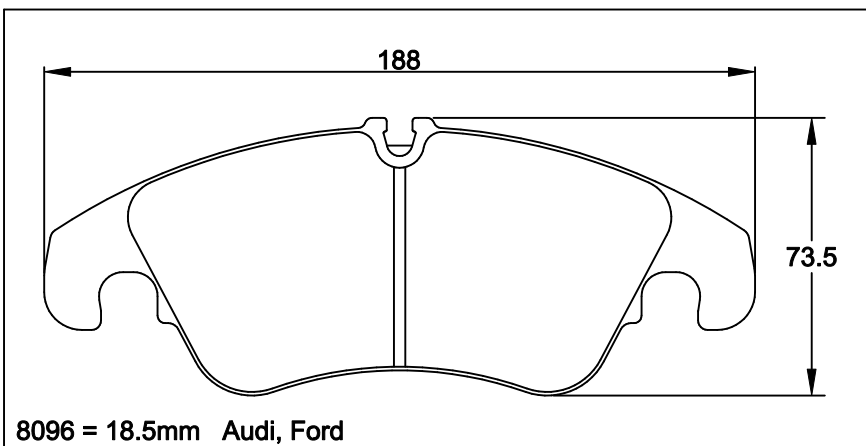

8096 = 18.5mm Audi, Ford

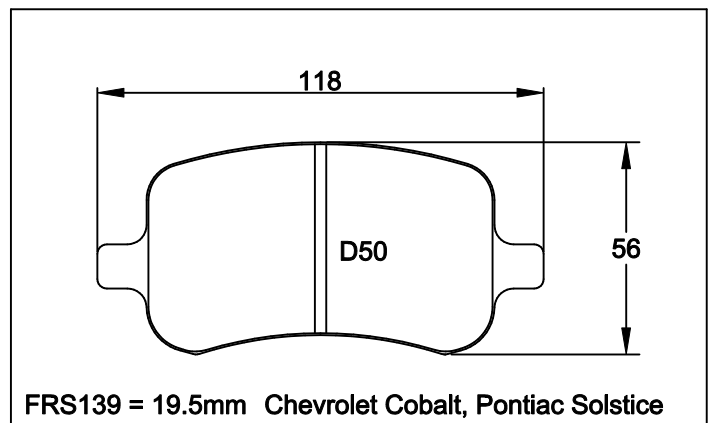
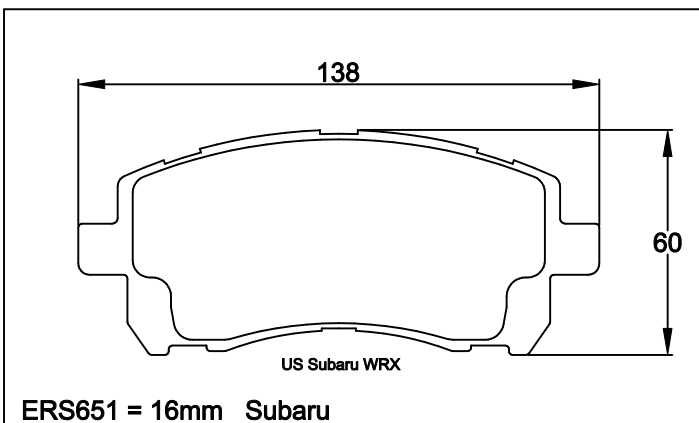
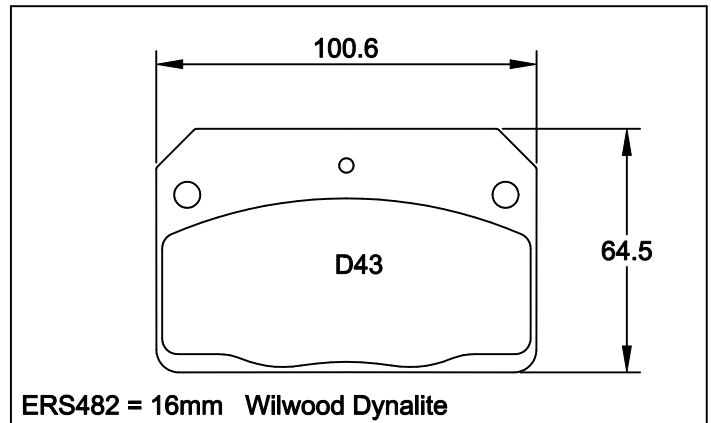
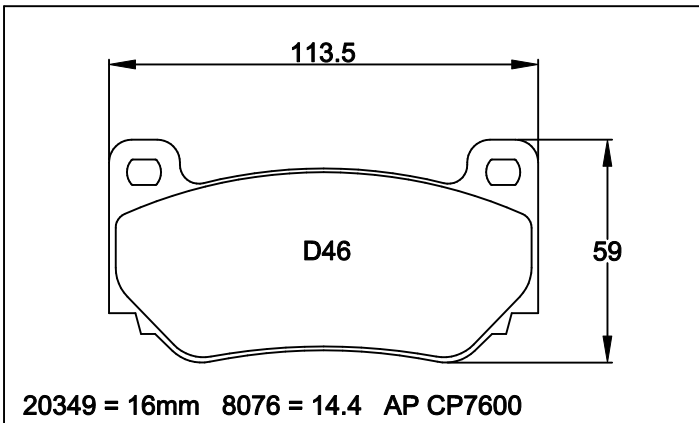
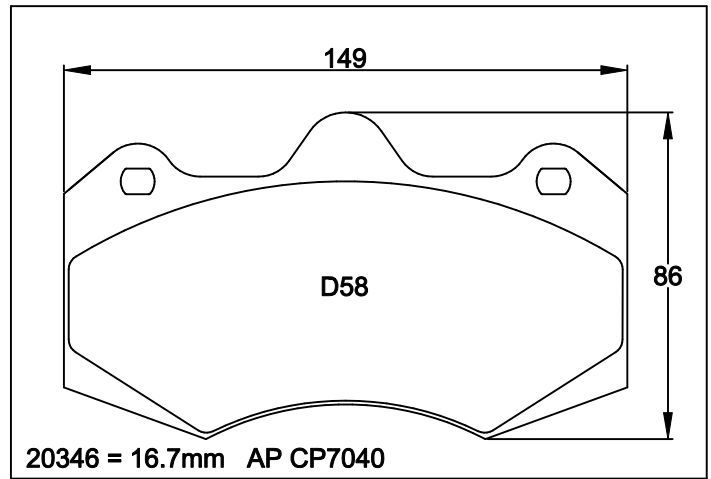
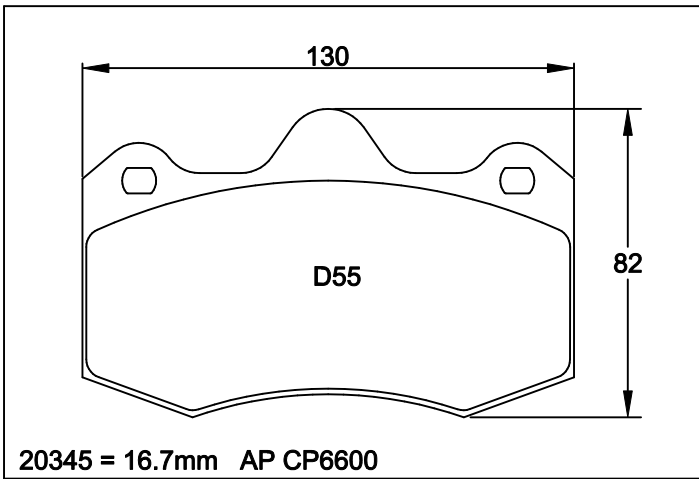
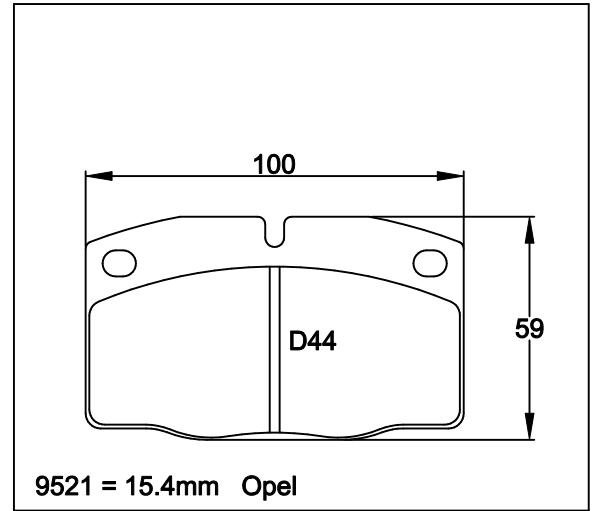
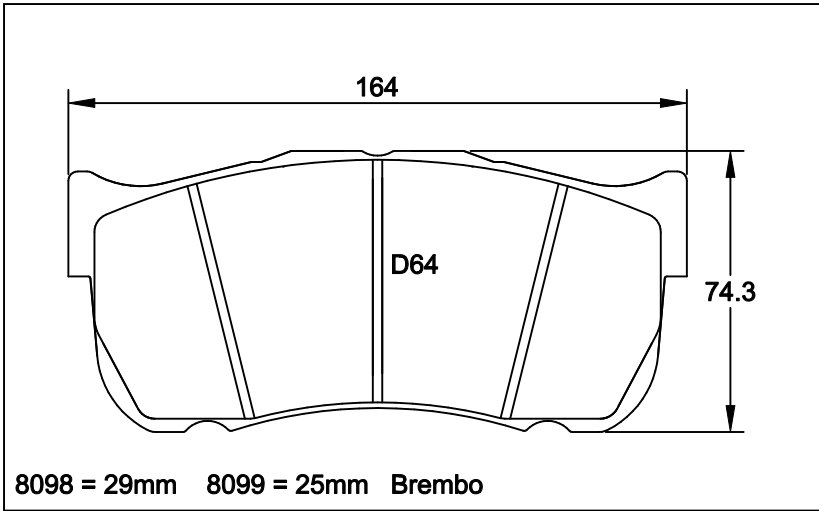

Illustrations are for identification purpose only. The right of modification in construction, design or model application is reserved.
Even if shown in the drawing, accessories such as clips, springs, rivets, wear indicators, damping shims etc. are generally not part of PAGID RS pads.