

VST Precision Filter Baskets

Chosen by the world's top roasters, cafés and world barista champions

Espresso, re-engineered.

www.vstapps.com



TIM WENDELBOE



RITUAL
COFFEE
ROASTERS



CAFÉ MYRIADE



George Howell Coffee



HAS BEAN
COFFEE
WWW.HASBEAN.CO.UK



PRUFROCK
COFFEE



SQUARE MILE
COFFEE ROASTERS



AIR COFFEE



For information about the science and engineering that go into VST Precision Filter Baskets



Introducing the VST 20g Precision Filter

VST inc Precision Filter Basket

All Sizes Now Available in Ridgeless Versions

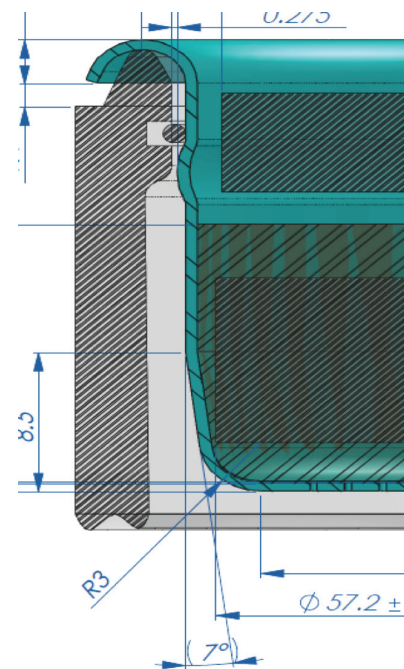

Competition Class

The new VST Precision Filter is optimized for use with 20 grams of coffee, the preferred dose used in WCE and WBC competitions.

Improved Espresso Quality

VST's new filters deliver consistent extraction performance over a wide range of concentration with reduced sediment and simplified preparation. Each VST filter is designed to extract properly as a Normale, Ristretto or Lungo.

Precision Fabrication

Built with unprecedented precision, all VST Filters are WARRANTED for ZERO DEFECTS. Holes are formed using a new micro-machine and finishing process.

- Area

100% of holes are measured on every filter for min/max range limits on area and diameter to a precision of better than +/- 30 µm (+/- 15µm typical).

- Circularity

All holes are measured for circularity, placement, square area and blocked holes.

- Uniformity

Filters are matched for total square area opening to +/- 5% to ensure identical group-to-group performance. (Typical filters vary from -50 to +100%)

Hole Placement

Hole pattern is centered to +/- 1.0 mm and placement is oriented for uniform extraction throughout the entire puck.

Hole Geometry

Wide outlet angle prevents clogging, anti-wear design ensures uniform extraction performance for life of product.

Superior Material

Improved structural integrity, will withstand deflection from pump cycling without premature fatigue failures. (see VST Warranty)

Capacities

Capacities and Dimensions

(In both Ridged and Ridge-less models)

VST Filter	Dose (g)	Height (mm)	Diameter		Date Available
			Outside (mm)	Tamper (mm)	
20g Competition	19-21	26.0	60.0	58.3-58.4	Q4
22g Triple	21-23	28.0	60.0	58.3-58.4	Now
18g Double	17-19	24.2	60.0	58.3-58.4	Now
15g DBL-EUR	14-16	22.0	60.0	58.3-58.4	Now

Compatibility

Designed to fit most 60mm Portafilters. (see DIMENSIONS, above and VSTAPPS.COM for details)

Genuine Article

Each VST filter is marked with a unique 2-D code to ensure authenticity and specifications. 2-D code stores factory measurement, quality reports and image data.

VST Warranty

Each genuine VST filter is warranted to meet or exceed published specifications for one year or will be replaced free of charge.

Food Safety Certifications

RoHS; ECHA REACH; EU GENERAL - German, Italian, French; US FDA



VST 20-g Precision Competition Filter



Also Available in 15g, 18g, and 22g Capacities

Available Q4 2011

Order online at:
www.vstapps.com