



**Power Controller Module  
(PCM)  
And Display  
(PCMD)**



---

## **Feature Summary**

The PowerTech PCM controls all of the start and run processes and characteristics of any PowerTech generator. The features of the application are:

### **Internal Ambient Temperature Sensor**

Provides an on-board temperature sensor.

### **Oil Pressure Sensor / Switch Input**

Allows input from an external oil pressure sensor or switch. Will shut down the generator if sufficient pressure is not detected after a start-up period.

### **Coolant Sensor / Switch Input**

Allows input from an external coolant temperature sensor or switch. Will shut down the generator if extreme temperature is detected.

### **Auxiliary (Generic) Shutdown Switch Input**

Allows input from any external active low (ground) switch. An active state of this switch will shut down the generator immediately.

### **DC Power Supply Voltage Measurement**

Measures the voltage level of the DC power supply. The DC voltage is monitored for a minimum and will shutdown the Generator if it falls below a threshold (configuration parameter). This is also reported on the PCM.

### **AC Output Voltage Measurement**

Measures the voltage level of the AC output. This information is monitored to detect limit conditions. It also is reported on the PCM. Over and Under Voltage conditions are reported.

### **AC Output Current Measurement**

Measures the current level of the AC output. The data is reported on the PCM and is used for current, wattage, and load measurement.

### **AC Output Frequency Measurement**

Measures the frequency level of the AC output. This info is monitored to detect a valid start as well as limit conditions. It also is reported on the PCM. Over and Under Frequency conditions are reported.

### **Warm Start**

Adjusts the Pre-Heat glow plug activation time according to the coolant temperature.

### **One-Touch Remote Start Trigger**

In addition to control via PCM, the unit will respond to an active high digital input. The unit can be configured to either start or stop in response to activation of a momentary switch or a toggle switch.

### **Blink Code Fault Reporting**

Simple diagnostic data is available through blink codes on a dedicated active high output. The PCM state as well as fault codes are displayed.

### **Event Recording**

A portion of non-volatile memory is dedicated to recording diagnostic and other events. If a clock is available on the network, the time and date of the event is included. Events include diagnostic messages, starts, stops, and configuration changes. Total event capacity is roughly 2,000 events.

### **Load Profiling**

The unit records the total amount of time the generator spends in each of several load intervals. The information is recorded each time the generator stops, showing the usage profile for that specific cycle.

### **AGS**

Automatic Generator Starting for low battery voltage. Programmable at the factory voltage threshold and run time. Unit can sense genset battery voltage or any other battery voltage as required. Enabled or disabled by an external switch.

### **Ignition Sensing**

Will shutdown genset or prevents genset from starting if DC voltage is applied from any external source. (Example: vehicle ignition, shore power sensor, or transfer switch, etc...)

### Starting

The generator starts in response to the “START” button being depressed for 1 second. The PCM goes into the Pre-Heat State, followed by the Cranking State, then finally, the Running State. The PCM attempts to start the generator a specific number of times (configuration parameter) before declaring a Fault. The shutdown inputs are checked before the start is attempted. If any of these inputs are active, the start process is aborted.

See the following sections for more detailed information about each state.

### Stopping

The generator stops in response to the “START” button being depressed for 1 second. All relays are returned to their reset condition (OFF). Inputs to the PCM are not actively monitored, except the Start/Stop Button. The LED is turned off. The PCM enters the Idle State.

### Power Cycle/Reset

If the power to the PCM is cycled, it will immediately shut down all relay outputs, stopping the generator. The unit will start with all fault and status flags reset. There may be a pause of several seconds before all the configuration information is processed and the unit is ready to accept input.

### Idle State

The Idle State is the initial state of the PCM after a Power Cycle/Reset. The PCM returns to this state after a Stop Command. The LED is not lit.

### Pre-Heat State

The Pre-Heat State is necessary to energize the Glow Plugs for the Cranking State. The Fuel Pump is active. The duration of this state is determined by using the coolant temperature according to the formula:

< 23 °F	cranking time = 15 seconds
23 °F – 50 °F	cranking time = 8 seconds
> 50 °F	cranking time = 5 seconds

The LED blinks.

### Cranking State

The Cranking State attempts to start the generator combustion. The starter and fuel pump are active. Successful sustaining combustion is determined by measuring the AC Line 1 output frequency. The LED blinks.

### Running State

After an initial “ignore” time (configuration parameter), inputs are monitored for out-of-bounds limits and, if needed, a shutdown command is issued. The LED is lit.

### Fault State

The Fault State is entered if an input reaches an out-of-bounds limit. The generator is immediately stopped. A Power Cycle/Reset is required to exit the Fault state. The LED blinks the Fault Code(s) (see next section).

## Automatic Generator Start (AGS)

The Automatic Generator Start (AGS) allows the generator to start based upon the battery level. The trigger voltage is configurable via a configuration parameter. The entire feature can be enabled/disabled by a configuration parameter. The AGS feature is currently disabled, by default.

## Safety Monitoring And Shutdown

The PCM monitors inputs for safety limitations which might damage the generator. If any input is outside of the safe operating range, the generator is immediately shutdown and the PCM enters the FAULT state. The PCM remains in the FAULT state until a power cycle or reset occurs. The shutdown reason is displayed by blinking the LED.

The thresholds used in determining faults are set by configuration parameters.

These inputs are only monitored when the generator is in the RUNNING state. Before starting the generator, the following inputs are checked to see whether a start should be attempted: High Coolant Temperature, Auxiliary switch, Ignition Sense, DC Voltage and High Ambient Temperatures.

These inputs are averaged over 0.6 seconds to help eliminate noise and settling issues. This averaging helps to eliminate falsely signaled shutdowns.

### Shutdown Reasons

Fault Reason	Fault Code	Description
Failure to Start	1	The generator was not able to start.
High Coolant Temperature	2	The generator coolant temperature has reached a high threshold.
Low Oil Pressure	3	The generator oil pressure has reached a critically low pressure.
High Ambient (Air) Temperature	4	The PCM measures an ambient air temperature above a specific threshold. <b>NOTE: Temperature inside the Control Box.</b>
AC Fault	5	A Fault with the AC was detected.
DC Fault	6	A Fault with the DC (Battery) was detected.
Auxiliary Input Active	7	The Auxiliary input is active.
Sensor Malfunction	8	One of the sensors has malfunctioned..
Ignition Sense	9	Ignition Sense is active.

The fault codes are displayed on the LED by blinking a number of times equal to the fault code, then going dark for two seconds. Multiple fault codes are displayed in the order that they have occurred. This cycle repeats until the fault is cleared by a power cycle, reset or via RV-C.

## LED Sequences

The LED on the Start Button is used to communicate the state of the generator in addition to any fault conditions. The PCM states are different from the Fault Codes in that the states are displayed continuously (i.e. no two second pause).

### PCM State

PCM State	LED	Notes
Idle State	off	
Pre-Heat	Blink (25% duty cycle)	
Cranking State	Blink (50% duty cycle)	
Running State	on	
Fault State	<various>	See "Shutdown Reasons" Section

# ENGINE TROUBLE SHOOTING

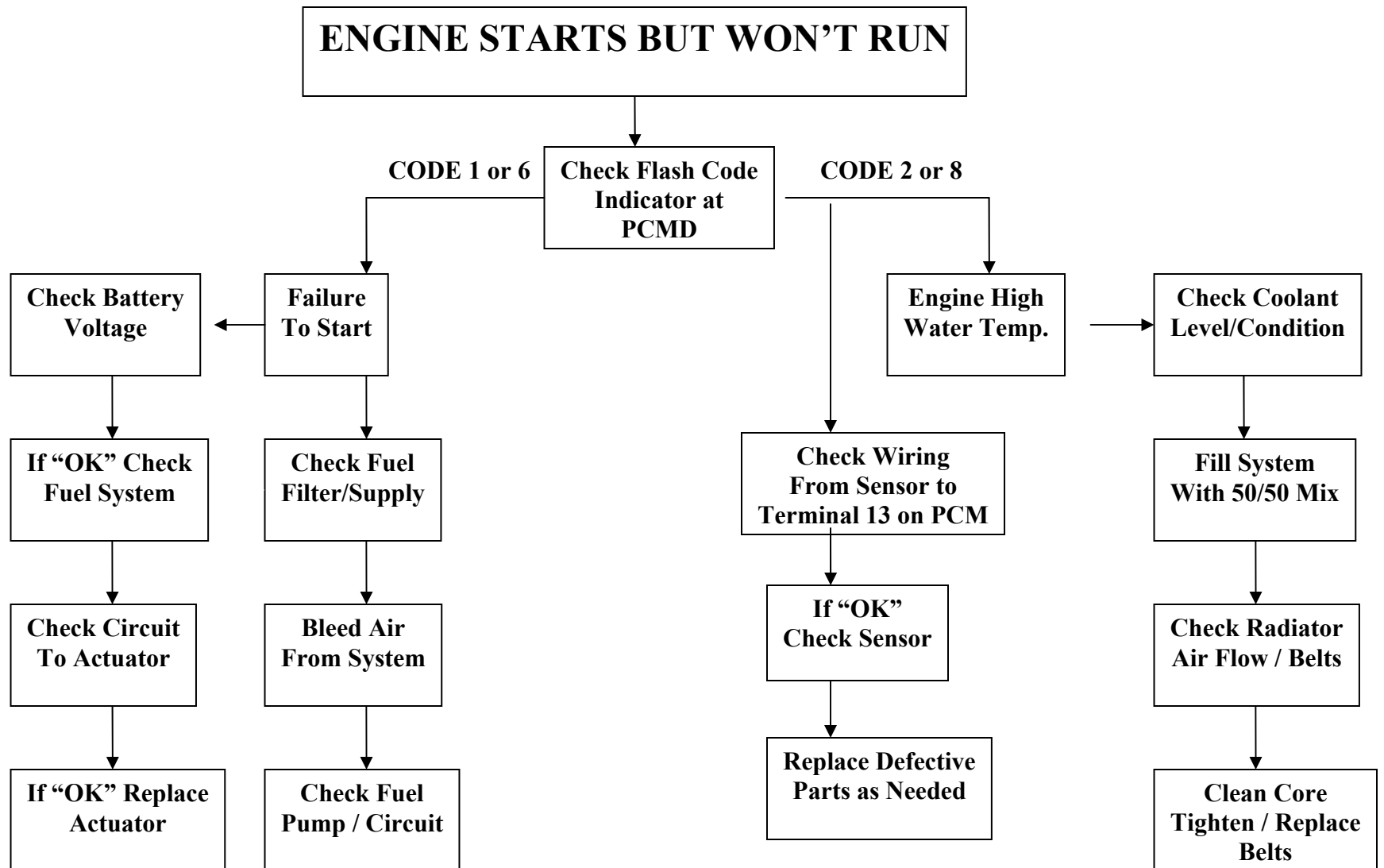

# ENGINE TROUBLE SHOOTING

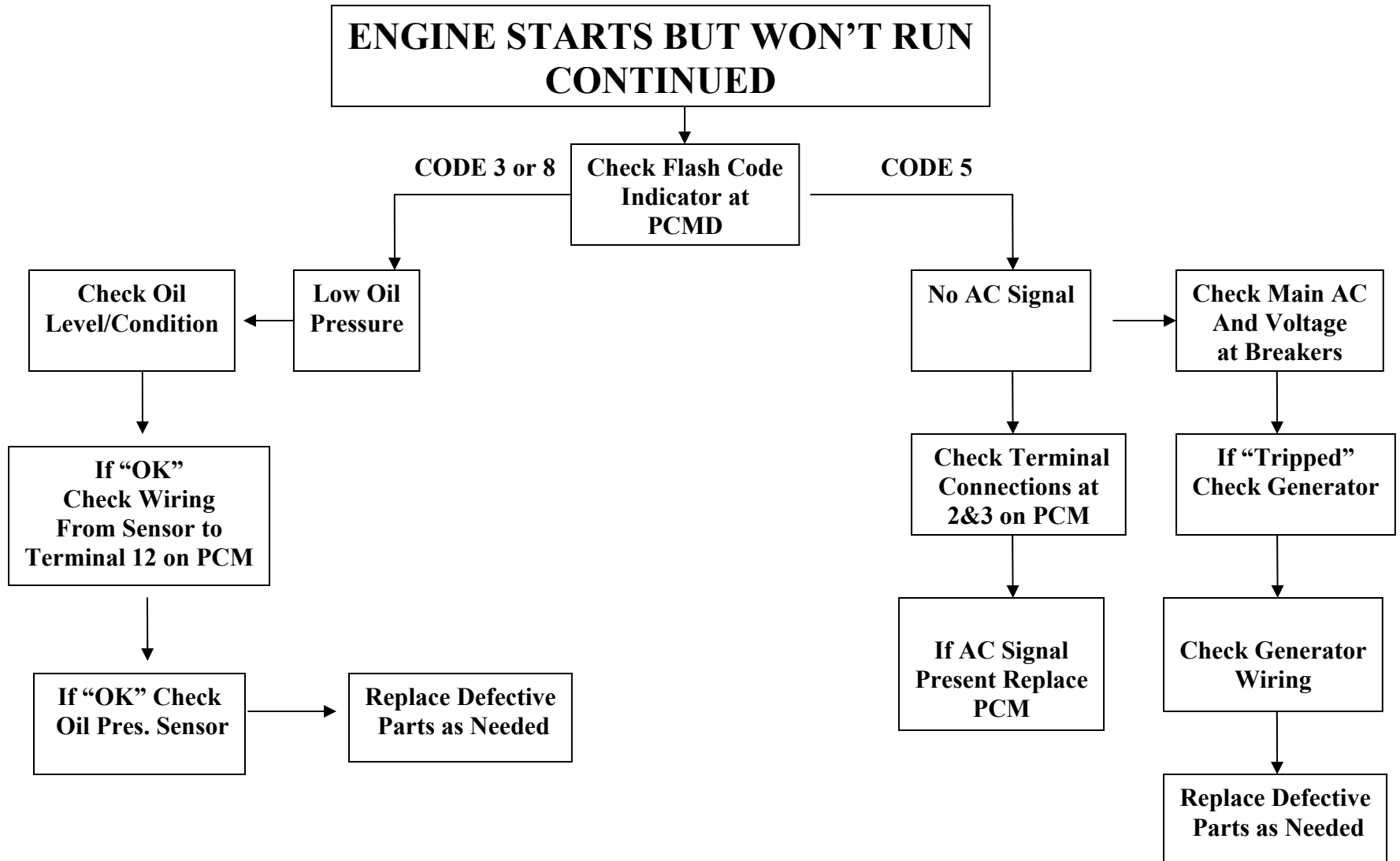



POWER TECHNOLOGY SOUTHEAST, INC.  
 634 STATE ROAD 44  
 LEESBURG, FL 34748-8103  
 (352) 365-2777 FAX (352) 787-5545

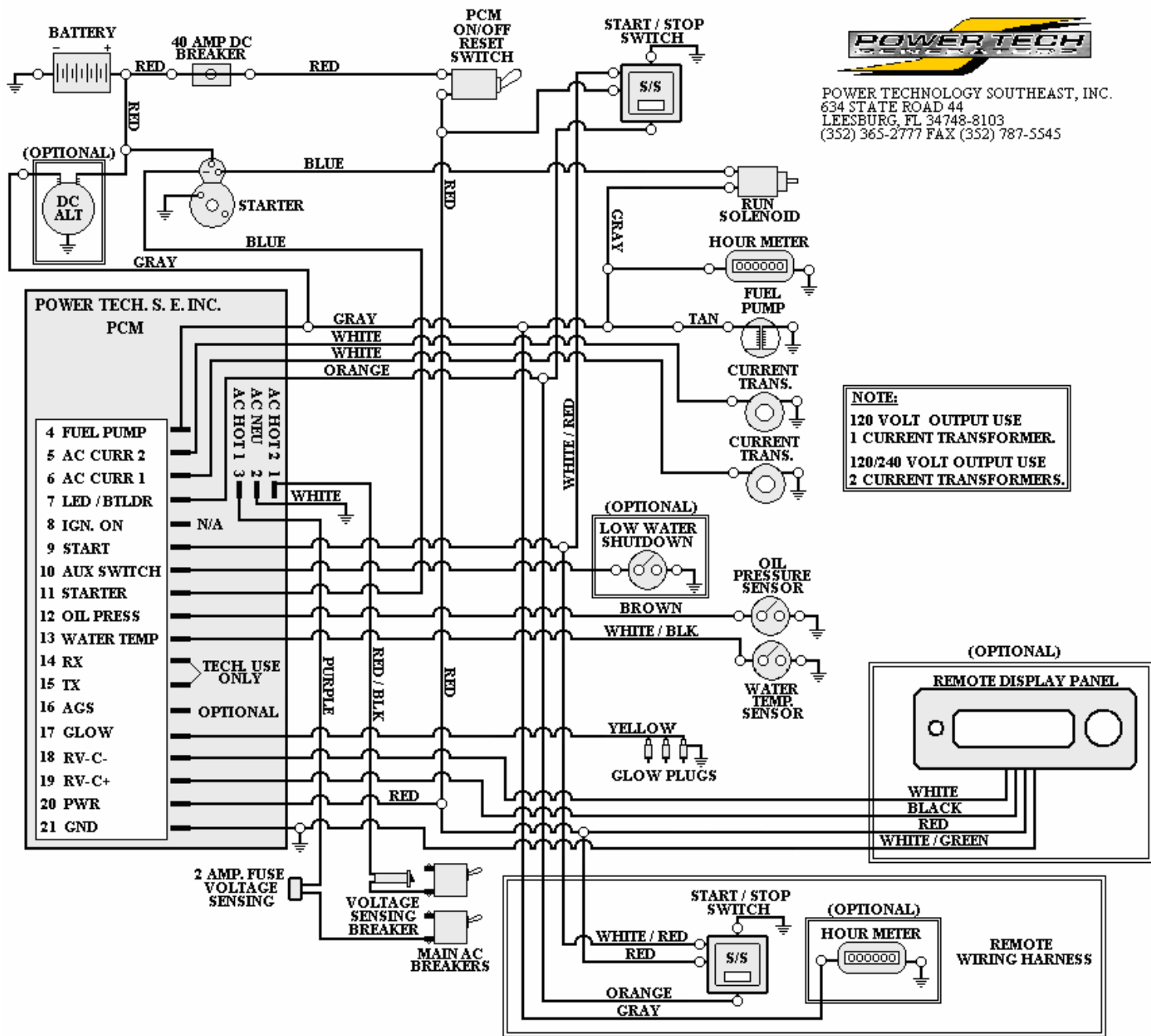

## KUBOTA 12Volt DC POWER CONTROL MODULE WIRING SCHEMATIC