

FICHE D'HOMOLOGATION HOMOLOGATION FORM



COMMISSION INTERNATIONALE DE KARTING - FIA



MOTEUR / ENGINE ICA

Constructeur	<i>Manufacturer</i>	TM RACING – ITALY
Marque	<i>Make</i>	TM RACING
Modèle	<i>Model</i>	K11 B
Type d'admission	<i>Inlet type</i>	REED VALVE
Durée de l'homologation	<i>Validity of the homologation</i>	6 ans / 6 years
Nombre de pages	<i>Number of pages</i>	7

La présente Fiche d'Homologation reproduit descriptions, illustrations et dimensions du moteur au moment de l'homologation CIK-FIA. Le Constructeur a la possibilité de les modifier seulement dans les limites fixées par le règlement CIK-FIA en vigueur. La hauteur du moteur complet sur les photos doit être de 7cm minimum.

This Homologation Form reproduces descriptions, illustrations and dimensions of the engine at the moment of the CIK homologation. The Manufacturer may modify them, but only within the limits fixed by the CIK-FIA regulations in force. The height of complete engines on all photos must be minimum 7cm.

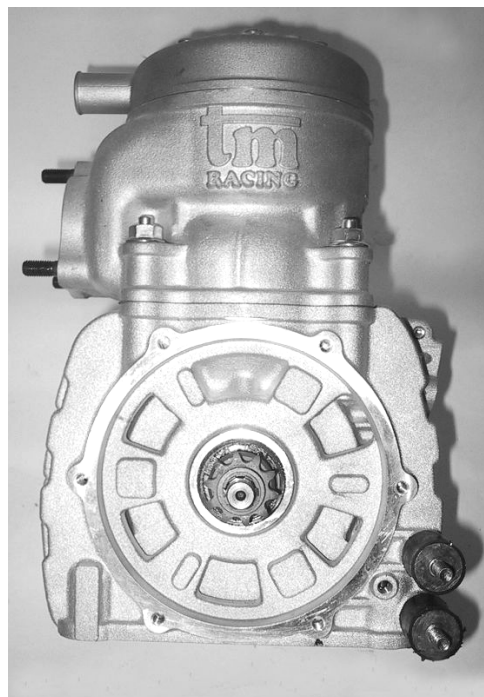

PHOTO DU MOTEUR CÔTÉ PIGNON
PHOTO OF DRIVE SIDE OF ENGINE



PHOTO DU MOTEUR CÔTÉ OPPOSÉ
PHOTO OF OPPOSITE SIDE OF ENGINE

Signature et tampon de l'ASN
Signature and stamp of the ASN

Signature et tampon de la CIK-FIA
Signature and stamp of the CIK-FIA



Glauco



[Signature]

INFORMATIONS TECHNIQUES		TECHNICAL INFORMATION	
A	CARACTÉRISTIQUES	A	CHARACTERISTICS
			Tolérances
Volume du cylindre	<i>Volume of cylinder</i>	99.27 CM3	< 100cm³
Alésage d'origine	<i>Original Bore</i>	49.98 MM	
Alésage théorique maximum	<i>Theoretical maximum bore</i>	50.16 MM	
Course	<i>Stroke</i>	50.60 MM	
Système de refroidissement	<i>Cooling system</i>	WATER	
Nombre de systèmes de carburation	<i>Number of carburation systems</i>	1 CARBURATOR	
Nombre de canaux de transfert, cylindre/carter	<i>Number of transfer ducts, cylinder/sump</i>	3	
Nombre de lumières / canaux d'échappement	<i>Number of exhaust ports / ducts</i>	3	
Forme de la chambre de combustion	<i>Shape of the combustion chamber</i>	SPHERIC WITH VARIABLE RADIUS + SQUISH	
Longueur (entre-axe) de la bielle	<i>Length between the axes of the connecting rod</i>	101 MM	±0.1mm
Poids de la bielle	<i>Weight of the connecting rod</i>	100.0 GR	minimum
Poids du vilebrequin	<i>Weight of the crankshaft</i>	1604 GR	minimum
Volume de la chambre de combustion	<i>Volume of combustion chamber</i>	6.5 CM3	minimum
Modifications autorisées selon le Règlement Technique. Seules les dimensions et cotes qui ne peuvent pas être modifiées doivent figurer sur la Fiche d'Homologation.			
<i>Modification allowed according to the Technical Regulations. Only the dimensions and readings which may not be changed must be mentioned on the Homologation Form.</i>			

B	ANGLES D'OUVERTURE	B	OPENING ANGLES
De l'échappement	<i>Exhaust</i>	177°	Maximum

C	MATÉRIAU	C	MATERIAL
Cylindre	<i>Cylinder</i>	ALLUMINIUM IRON LINER	
Culasse	<i>Cylinder head</i>	ALLUMINIUM	
Carter	<i>Sump</i>	ALLUMINIUM	
Bielle	<i>Connecting rod</i>	STEEL	

DESSIN DU DÉVELOPPEMENT DU CYLINDRE

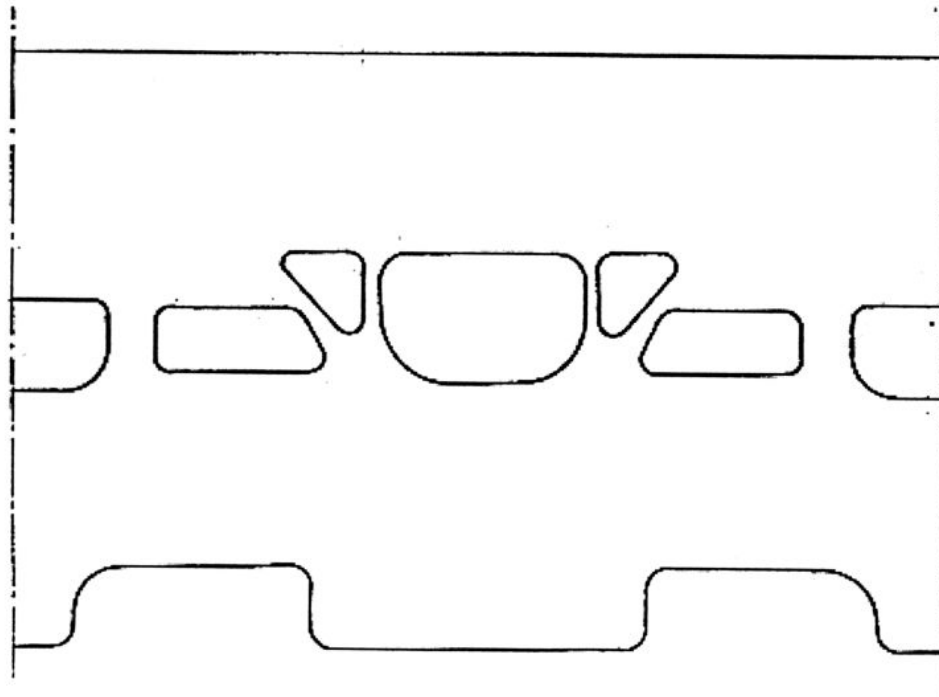
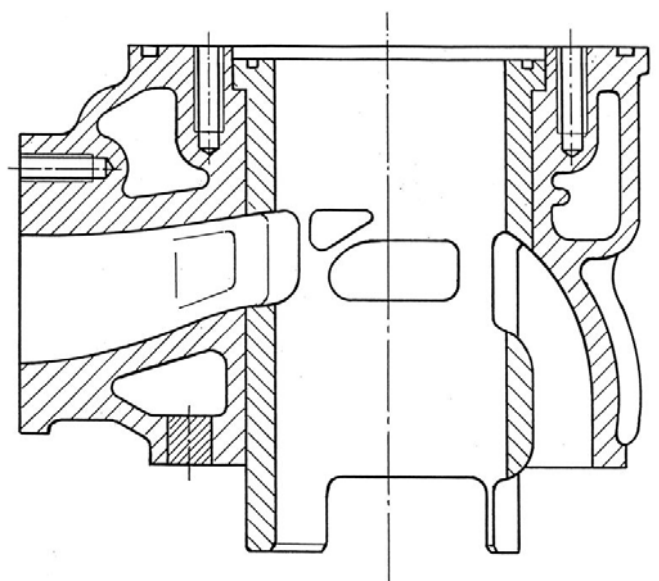
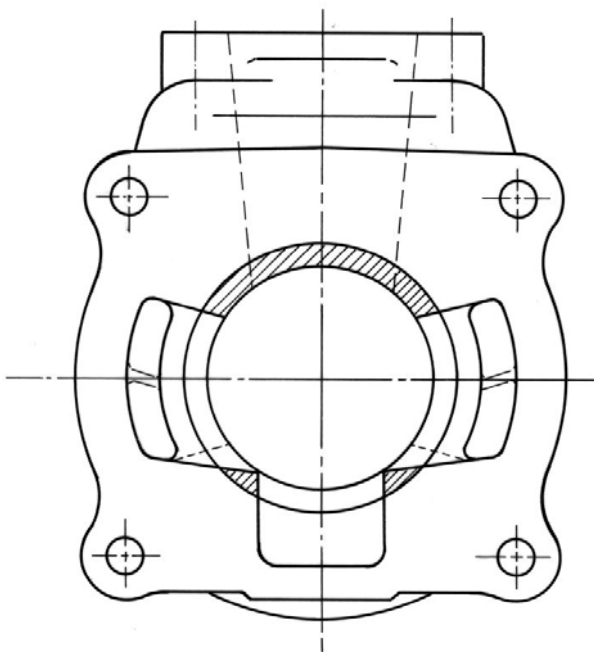
DRAWING OF THE CYLINDER DEVELOPMENTDESSIN DU PIED DU
CYLINDRE*DRAWING OF THE
CYLINDER BASE*VUE EN SECTION DU
CYLINDRE*CYLINDER SECTION
VIEW*

DESSIN DE LA CULASSE ET DE LA CHAMBRE
DE COMBUSTION

DRAWING OF THE CYLINDER HEAD AND OF
THE COMBUSTION CHAMBER

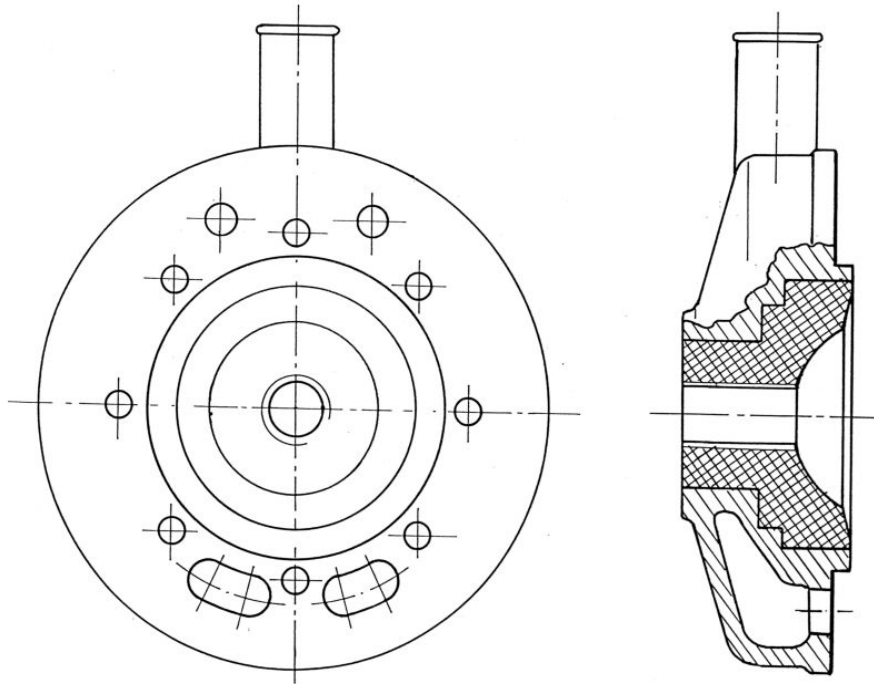

DESSIN DU
VILEBREQUIN

DRAWING OF THE
CRANKSHAFT

DESSIN INTÉRIEUR
DU CARTER

DRAWING OF THE
INSIDE OF SUMP

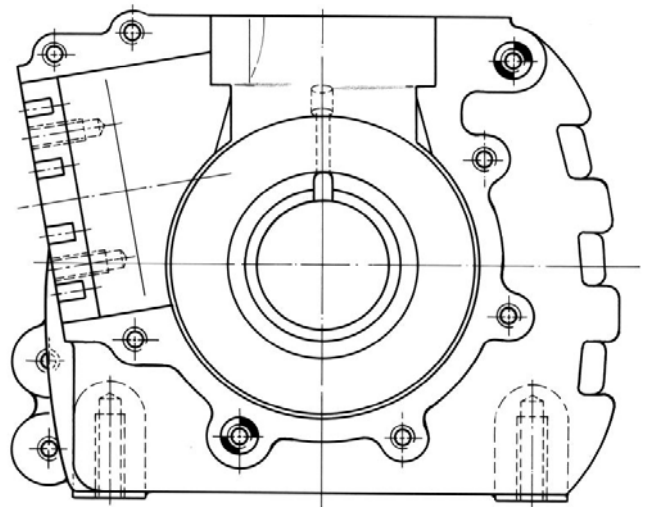
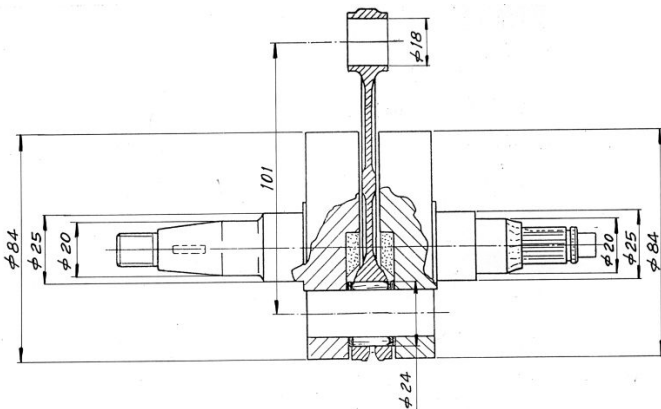



<p>PHOTO DE L'ARRIÈRE DU MOTEUR</p>	<p><i>PHOTO OF THE BACK OF THE ENGINE</i></p>	<p>PHOTO DE L'AVANT DU MOTEUR</p>	<p><i>PHOTO OF THE FRONT OF THE ENGINE</i></p>
			
<p>PHOTO DU MOTEUR PARTIE SUPÉRIEURE</p>	<p><i>PHOTO OF THE ENGINE TAKEN FROM ABOVE</i></p>	<p>PHOTO DU MOTEUR PARTIE INFÉRIEURE</p>	<p><i>PHOTO OF THE ENGINE TAKEN FROM BELOW</i></p>
			

PHOTO DU PIED DU CYLINDRE	<i>PHOTO OF THE BASE OF THE CYLINDER</i>	PHOTO DE LA CHAMBRE DE COMBUSTION	<i>PHOTO OF THE COMBUSTION CHAMBER</i>
			
PHOTO DU CARTER (CÔTÉ JOINT)	<i>PHOTO OF THE SUMP (GASKET FACE)</i>	PHOTO D'UNE PARTIE INTÉRIEURE DU CARTER	<i>PHOTO OF AN INTERNAL PART OF THE SUMP</i>
			

DESSIN DU SILENCIEUX ET DE SES
ÉLÉMENTSDRAWING OF THE SILENCER AND OF ITS
COMPONENTS

Épaisseur minimum de la paroi du pot-silencieux 0,8mm / Minimum thickness of the wall of the exhaust silencer 0.8mm.
Poids minimum de l'échappement 1,450 Kg / Minimum weight of the exhaust 1,450 Kg.

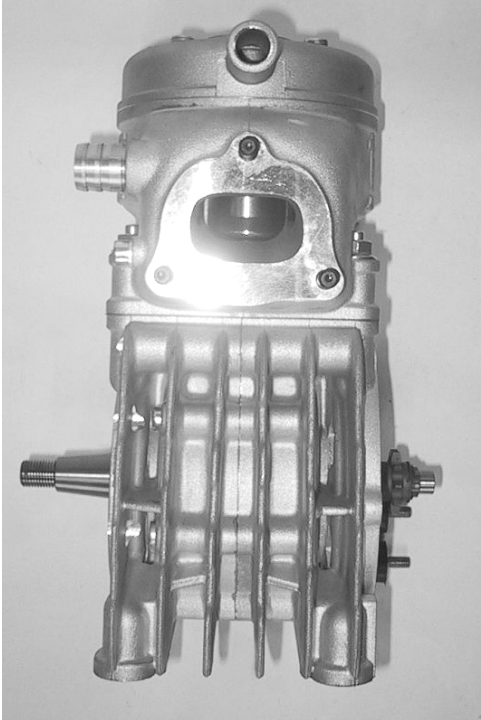
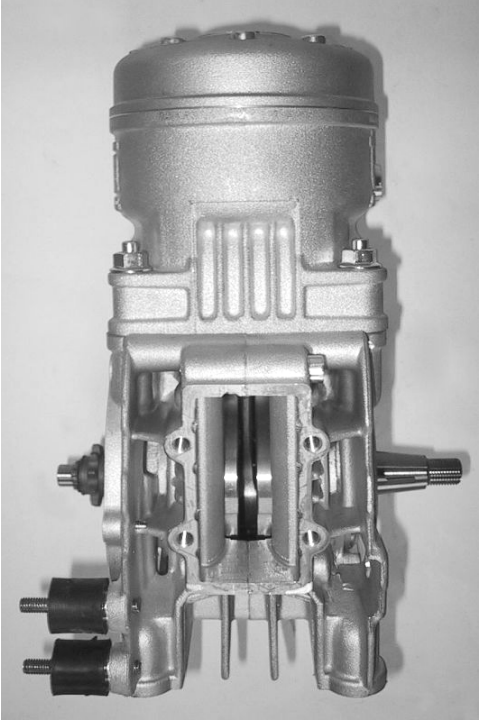
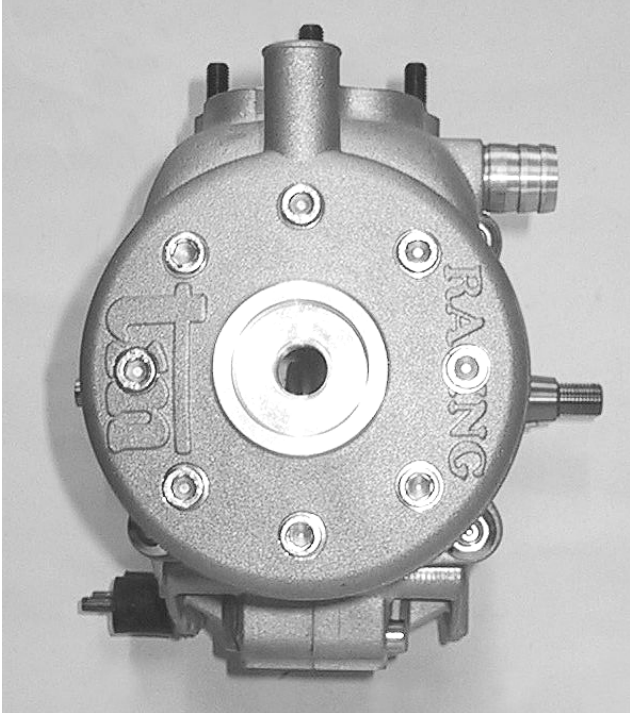
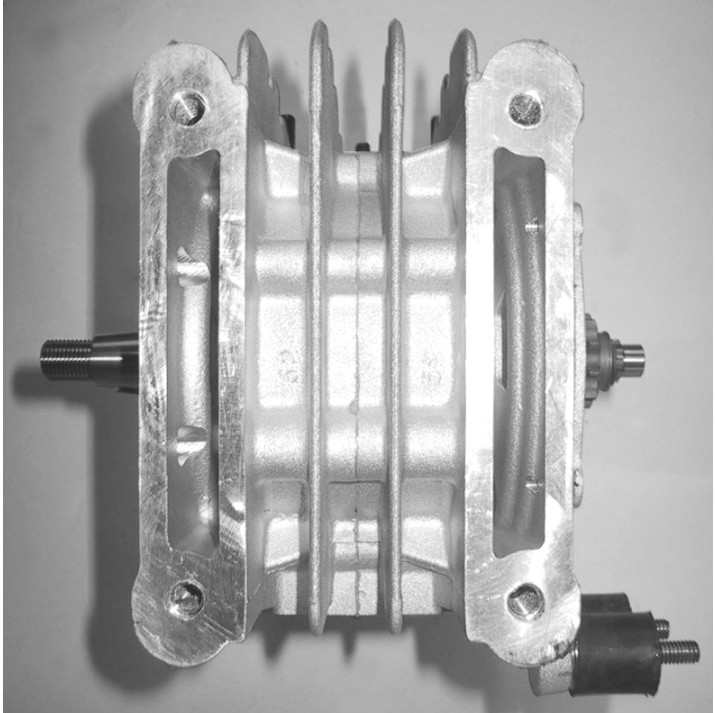

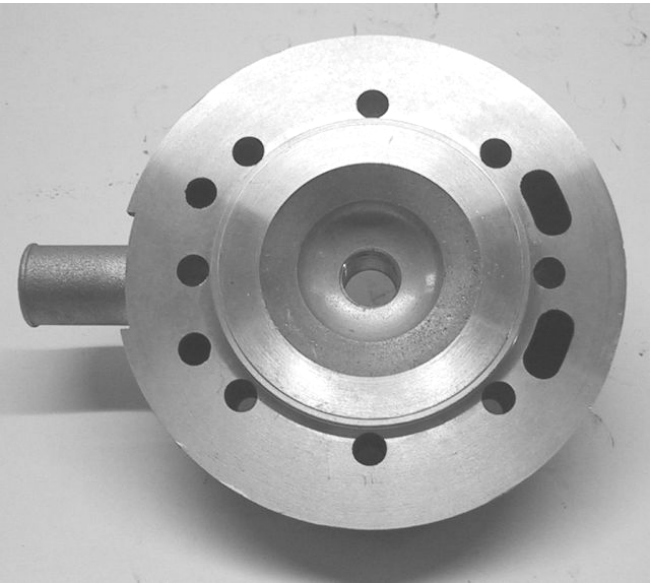
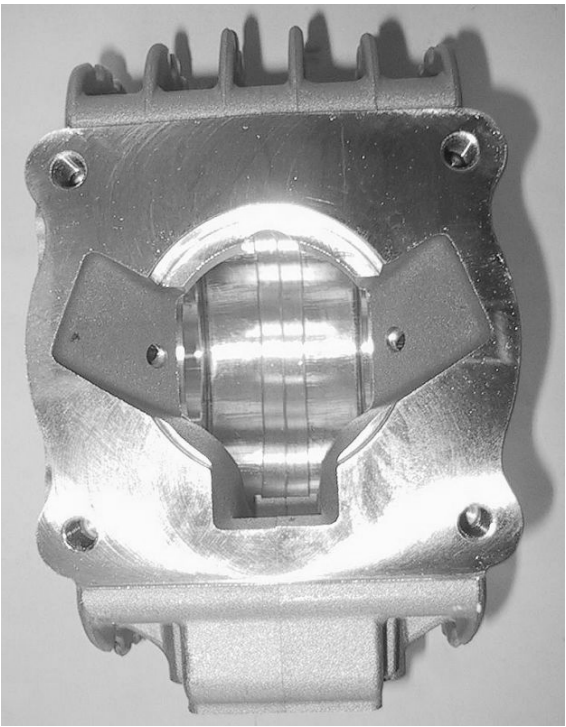
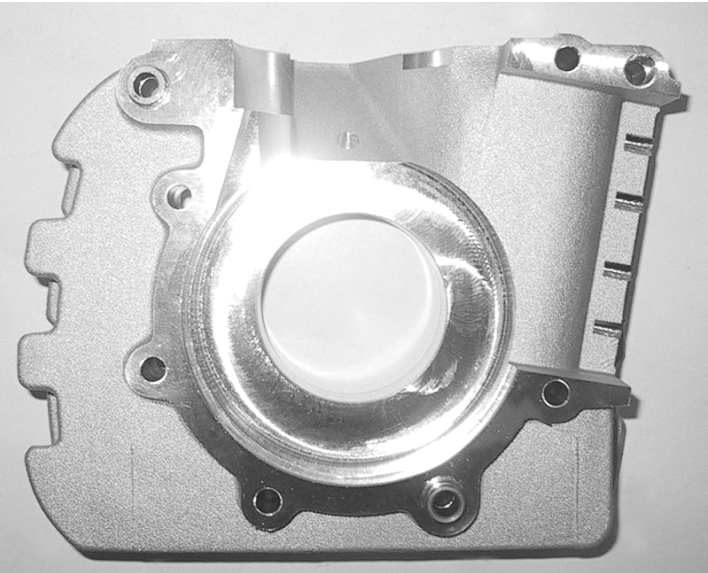
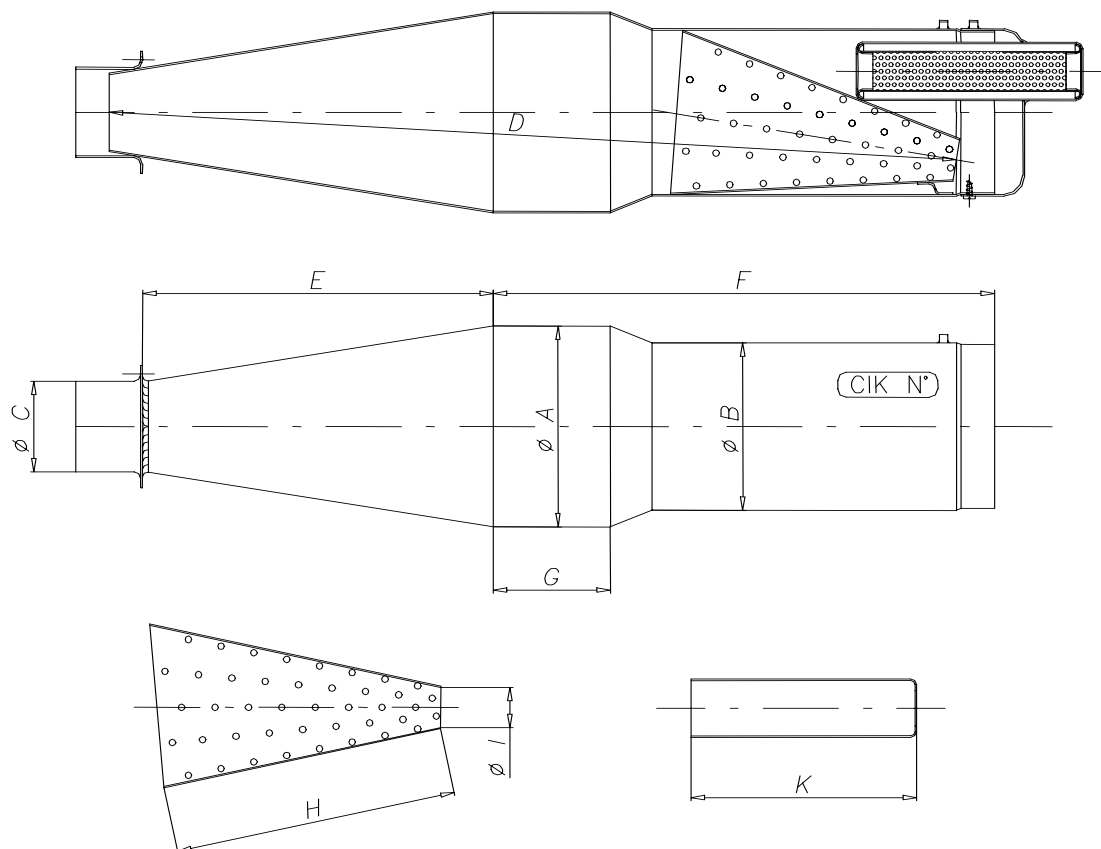
Les parties terminales du silencieux doivent présenter deux paires d'anneaux soudés (une en haut et une en bas), pour retenir le sceau en plomb fixé par l'Organisateur pour que le silencieux ne puisse pas être ouvert pendant la compétition.

The end parts of the silencer must have two soldered pairs of lugs (one pair at the top and one pair at the bottom) for the fixing of seals by the Organiser so that the silencer may be opened during the competition

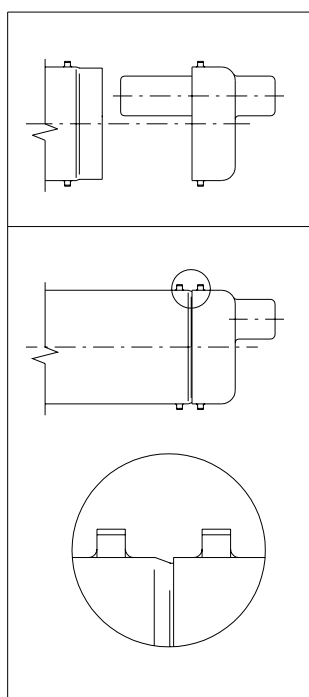

Cotes / Readings:

A: __ 112.5_ Øext.

F: __ 320 __

B: __ 100_ Øext.

G: __ 100 __

C: __ 54_ Øext.

H: __ 172 __

D: __ 478 __

I: __ 22 __

E: __ 173 __

K: __ 130 __

TOLÉRANCES

Cotes brutes / Rough dimensions
Jusque - up to 25mm → ±1mm
De à - from to 25-60mm → ±1,5mm
Plus que - more than 60mm → ±3mm