

# PH 3/2 Glass Table

table & floor



**Weblink**  
134

**Project page**  
330

**Design**  
Poul Henningsen

**Concept**  
PH 3/2 Glass Table (1927) provides a soft illumination. PH 3/2 is based on the principle of a reflecting multi-shade system, creating a harmonious and glare free illumination. The shades are drawn over a logarithmic spiral, with the center of the light source placed in the spiral's focal point.

**Finish**  
White opal glass. High lustre chrome plated.

**Material**  
Base: High lustre chrome plated, brass. Shades: Handblown white opal glass. Top plate: High lustre chrome plated, spun brass. Stem: High lustre chrome plated, brass.

**Mounting**  
Cord type: Black. Cord length: 9'. Switch: In-line on/off switch provided.

**Weight**  
Max. 6 lbs.

**Label**  
cUL, Dry location. IBEW.

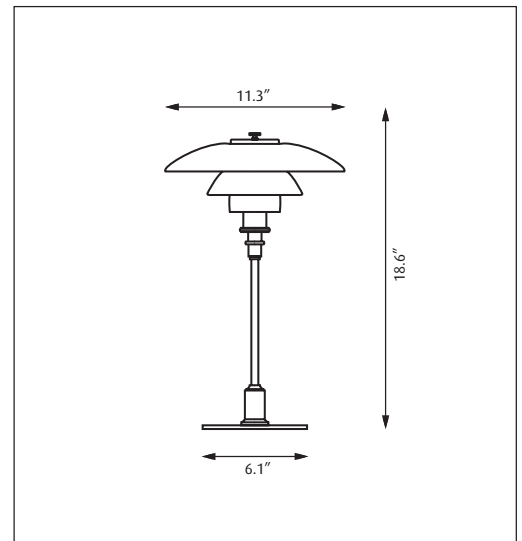

Product code	Light source	Voltage	Finish
PH3/2-T	1/60W/G16.5/IF candelabra	120V	GLASS

Info notes:  
I. All handblown opal glass shades are sandblasted on the undersides for uniform light distribution.  
II. The comparable EU version has the following classification: Ingress Protection Code: IP20.



118

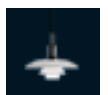

91



[AC Martin Partners](#)  
Los Angeles, California, USA  
[Architect](#)  
AC Martin Partners  
[Photo](#)  
Thomas Loof Photography